



**PROPRIETARY NOTE**

THIS SPECIFICATION IS THE PROPERTY OF BOE BJ AND SHALL NOT BE REPRODUCED OR COPIED WITHOUT THE WRITTEN PERMISSION OF BOE BJ AND MUST BE RETURNED TO BOE BJ UPON ITS REQUEST

SPEC. NUMBER	PRODUCT GROUP	Rev.	ISSUE DATE	PAGE
	TFT-LCD	P1	2016.03.23	1 OF 33

**NV156FHM-N35**

**Preliminary Product Specification**

**Rev. P0**

SPLCD.com  
Supply & Purchase Cloud Platform



CHONGQING BOE OPTOELECTRONICS TECHNOLOGY CO.,LTD



<b>BOE</b>	<b>PRODUCT GROUP</b>	REV	ISSUE DATE
	TFT- LCD PRODUCT	P1	2016.03.23
SPEC. NUMBER	SPEC. TITLE NV156FHM-N35 Preliminary Product Specification		PAGE 3 OF 33

## Contents

No.	Items	Page
	REVISION HISTORY	2
	CONTENTS	3
1.0	General Description	4
2.0	Absolute Maximum ratings	6
3.0	Electrical specifications.	7
4.0	Optical specifications.	10
5.0	Interface Connection	15
6.0	Signal Timing Specification	18
7.0	Input Signals, Display Colors & Gray Scale of Colors	20
8.0	Power Sequence	21
9.0	Connector description	22
10.0	Mechanical Characteristics	23
11.0	Reliability Test	24
12.0	Handling & Cautions.	24
13.0	Label	25
14.0	Packing information	27
15.0	Mechanical Outline Dimension	28
16.0	EDID Table	30

<b>BOE</b>	<b>PRODUCT GROUP</b>	REV	ISSUE DATE
	TFT- LCD PRODUCT	P1	2016.03.23
SPEC. NUMBER	SPEC. TITLE NV156FHM-N35 Preliminary Product Specification	PAGE 4 OF 33	

## 1.0 GENERAL DESCRIPTION

### 1.1 Introduction

NV156FHM-N35 is a color active matrix TFT LCD module using amorphous silicon TFT's (Thin Film Transistors) as an active switching devices. This module has a 15.6 inch diagonally measured active area with FHD resolutions (1920 horizontal by 1080 vertical pixel array). Each pixel is divided into RED, GREEN, BLUE dots which are arranged in vertical Stripe and this module can display 262,144 colors. The TFT-LCD panel used for this module is a low reflection and higher color type. Therefore, this module is suitable for Notebook PC. The LED Driver for back-light driving is built in this model. All input signals are eDP1.2 interface compatible.

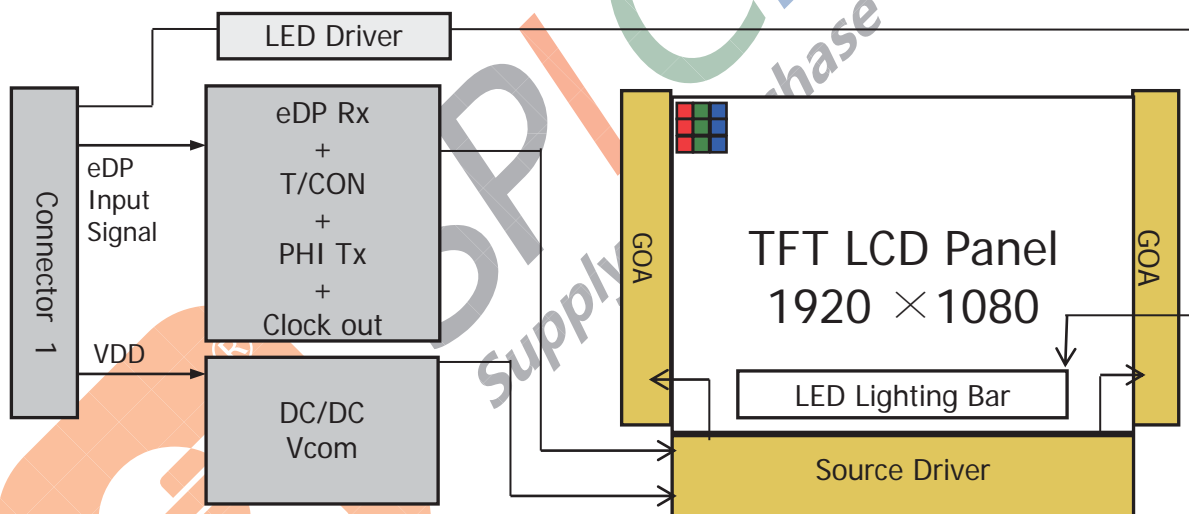

### 1.2 Features

- 2 lane eDP Interface with 2.7Gbps Link Rates
- Thin and light weight
- 6-bit color depth, display 262K colors
- Single LED Lighting Bar. (Down side/Horizontal Direction)
- Green Product (RoHS & Halogen free product)
- On board LED Driving circuit
- Low driving voltage and low power consumption
- On board EDID chip

<b>BOE</b>	<b>PRODUCT GROUP</b>	REV	ISSUE DATE
	TFT- LCD PRODUCT	P1	2016.03.23
SPEC. NUMBER	SPEC. TITLE NV156FHM-N35 Preliminary Product Specification	PAGE 5 OF 33	

### 1.3 Application

- Notebook PC (Wide type)

### 1.4 General Specification

The followings are general specifications at the model NV156FHM-N35. (listed in Table 1.)

<Table 1. General Specifications>

Parameter	Specification	Unit	Remarks
Active area	344.16 (H) × 193.59 (V)	mm	
Number of pixels	1920 (H) × 1080 (V)	pixels	
Pixel pitch	0.17925 (H) X 0.17925 (V)	mm	
Pixel arrangement	RGB Vertical stripe		
Display colors	262K	colors	
Display mode	Normally Black		
Dimensional outline	350.76(H)*216.195(V) (W/PCB)*3.2(Max)	mm	
Weight	380 (max)	g	
Surface treatment	glare		
Back-light	Lower Down side, 1-LED Lighting Bar type		Note 1
Power consumption	P <sub>D</sub> : 0.9	W	@mosaic
	P <sub>BL</sub> :3.0(max)	W	
	P <sub>total</sub> :3.9	W	@mosaic

Notes : 1. LED Lighting Bar (40\*LED Array)

<b>BOE</b>	<b>PRODUCT GROUP</b>	REV	ISSUE DATE
	TFT- LCD PRODUCT	P1	2016.03.23
SPEC. NUMBER	SPEC. TITLE NV156FHM-N35 Preliminary Product Specification	PAGE 6 OF 33	

## 2.0 ABSOLUTE MAXIMUM RATINGS

The followings are maximum values which, if exceed, may cause faulty operation or damage to the unit. The operational and non-operational maximum voltage and current values are listed in Table 2.

< Table 2. Absolute Maximum Ratings >  $T_a=25\pm 2^{\circ}\text{C}$

Parameter	Symbol	Min.	Max.	Unit	Remarks
Power Supply Voltage	$V_{DD}$	-0.3	4.0	V	Note 1
Logic Supply Voltage	$V_{IN}$	$V_{SS}-0.3$	$V_{DD}+0.3$	V	
Operating Temperature	$T_{OP}$	0	+50	$^{\circ}\text{C}$	Note 2
Storage Temperature	$T_{ST}$	-20	+60	$^{\circ}\text{C}$	

- Notes : 1. Permanent damage to the device may occur if maximum values are exceeded functional operation should be restricted to the condition described under normal operating conditions.
2. Temperature and relative humidity range are shown in the figure below.  
 95 % RH Max. (  $40^{\circ}\text{C} \geq T_a$  )  
 Maximum wet - bulb temperature at  $39^{\circ}\text{C}$  or less. (  $T_a > 40^{\circ}\text{C}$  ) No condensation.

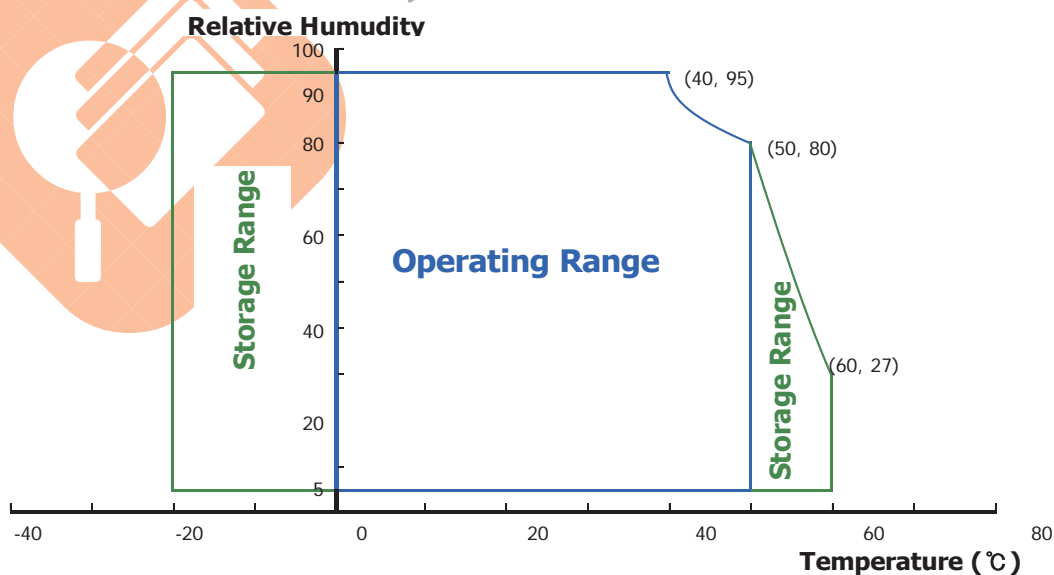

<b>BOE</b>	<b>PRODUCT GROUP</b>	REV	ISSUE DATE
	TFT- LCD PRODUCT	P1	2016.03.23
SPEC. NUMBER	SPEC. TITLE NV156FHM-N35 Preliminary Product Specification		PAGE 7 OF 33

### 3.0 ELECTRICAL SPECIFICATIONS

#### 3.1 Electrical Specifications

< Table 3. Electrical specifications >

Ta=25+/-2°C

Parameter		Min.	Typ.	Max.	Unit	Remarks
Power Supply Voltage	V <sub>DD</sub>	3.0	3.3	3.6	V	Note 1
Permissible Input Ripple Voltage	V <sub>RF</sub>	-	-	100	mV	At V <sub>DD</sub> = 3.3V
Power Supply Current	I <sub>DD</sub>	-	273	-	mA	Note 1
Differential Input Voltage	V <sub>ID</sub>	200	-	600	mV	
Power Consumption	P <sub>D</sub>	-	0.9	1.7	W	Note 1
	P <sub>BL</sub>	-	-	3.0	W	Note 2
	P <sub>total</sub>	-	3.9	4.7	W	

Notes : 1. The supply voltage is measured and specified at the interface connector of LCM.  
The current draw and power consumption specified is for 3.3V at 25°C.

a) Typ : Mosaic Pattern

b) Max : R/G/B Pattern

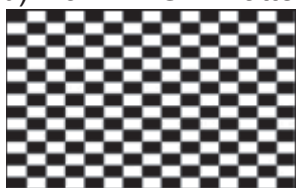

2. Calculated value for reference (V<sub>L</sub>LED × I<sub>L</sub>LED)

7

<b>BOE</b>	<b>PRODUCT GROUP</b>	REV	ISSUE DATE
	TFT- LCD PRODUCT	P1	2016.03.23
SPEC. NUMBER	SPEC. TITLE NV156FHM-N35 Preliminary Product Specification	PAGE 8 OF 33	

### 3.2 Backlight Unit

< Table 4. LED Driving guideline specifications > Ta=25+/-2°C

Parameter		Min.	Typ.	Max.	Unit	Remarks
LED Forward Voltage	V <sub>F</sub>	-	-	3.0	V	-
LED Forward Current	I <sub>F</sub>	-	22	-	mA	-
LED Power Consumption	P <sub>LED</sub>	-	-	3.0	W	Note 1
LED Life-Time	N/A	15,000	-	-	Hour	I <sub>F</sub> = 20mA
Power supply voltage for LED Driver	V <sub>LED</sub>	5	12	21	V	
EN Control Level	Backlight on	2.5		5.0	V	
	Backlight off	0		0.6	V	
PWM Control Level	PWM High Level	2.5		5.0	V	
	PWM Low Level	0		0.6	V	
PWM Control Frequency	F <sub>PWM</sub>	100	-	10,000	Hz	
Duty Ratio	-	1	-	100	%	Note3

Notes : 1. Power supply voltage 12V for LED Driver

Calculator Value for reference  $I_F \times V_F \times 54 / \text{efficiency} = P_{LED}$

2. The LED Life-time define as the estimated time to 50% degradation of initial luminous.

3. 1% duty cycle is achievable with a dimming frequency less than 1KHz.



### 3.3 LED structure

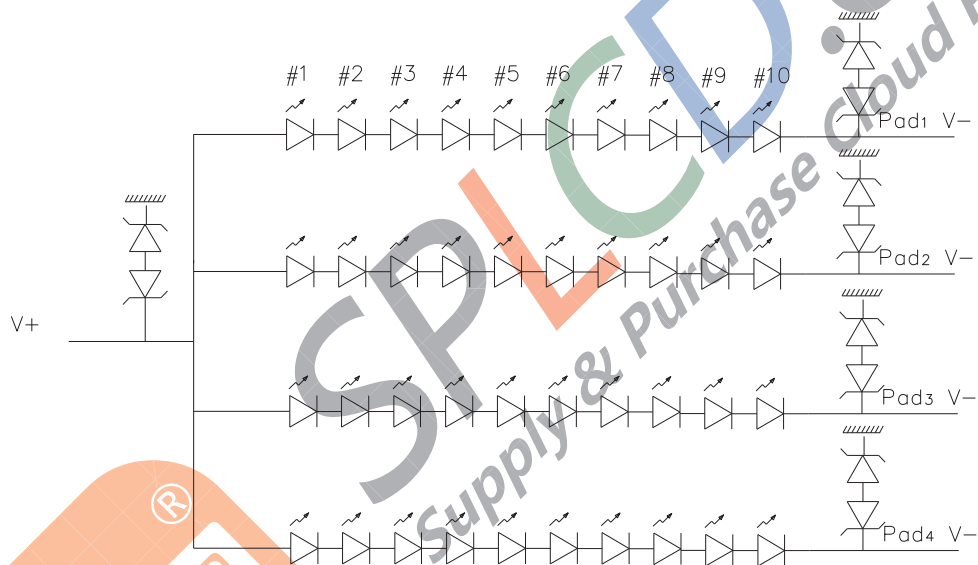

<b>BOE</b>	<b>PRODUCT GROUP</b>	REV	ISSUE DATE
	TFT- LCD PRODUCT	P1	2016.03.23
SPEC. NUMBER	SPEC. TITLE NV156FHM-N35 Preliminary Product Specification	PAGE 10 OF 33	

## 4.0 OPTICAL SPECIFICATION

### 4.1 Overview

The test of Optical specifications shall be measured in a dark room (ambient luminance  $\leq 1$  lux and temperature =  $25 \pm 2^\circ\text{C}$ ) with the equipment of Luminance meter system (Goniometer system and PR730) and test unit shall be located at an approximate distance 50cm from the LCD surface at a viewing angle of  $\theta$  and  $\Phi$  equal to  $0^\circ$ . We refer to  $\theta\Phi=0$  ( $=\theta_3$ ) as the 3 o'clock direction (the "right"),  $\theta\Phi=90$  ( $=\theta_{12}$ ) as the 12 o'clock direction ("upward"),  $\theta\Phi=180$  ( $=\theta_9$ ) as the 9 o'clock direction ("left") and  $\theta\Phi=270$  ( $=\theta_6$ ) as the 6 o'clock direction ("bottom"). While scanning  $\theta$  and/or  $\Phi$ , the center of the measuring spot on the Display surface shall stay fixed. The backlight should be operating for 30 minutes prior to measurement. VDD shall be  $3.3 \pm 0.3\text{V}$  at  $25^\circ\text{C}$ . Optimum viewing angle direction is 6 o'clock.

### 4.2 Optical Specifications

<Table 5. Optical Specifications>

Parameter		Symbol	Condition	Min.	Typ.	Max.	Unit	Remark
Viewing Angle range	Horizontal	$\theta_3$	CR > 10	-	85	-	Deg.	Note 1
		$\theta_9$		-	85	-	Deg.	
	Vertical	$\theta_{12}$		-	85	-	Deg.	
		$\theta_6$		-	85	-	Deg.	
Luminance Contrast ratio		CR	$\theta = 0^\circ$	-	700	-	-	Note 2
Luminance of White	5 Points	$Y_w$	$\theta = 0^\circ$	-	220	-	cd/m <sup>2</sup>	Note 3
White Luminance uniformity	5 Points	$\Delta Y_5$	$I_{LED} = 22.0\text{mA}$	80%	-	-	-	Note 4
	13 Points	$\Delta Y_{13}$		65%	-	-	-	
White Chromaticity		$x_w$	$\theta = 0^\circ$	0.283	0.313	0.343	-	Note 5
		$y_w$		0.299	0.329	0.359	-	
Reproduction of color	Red	$x_R$	$\theta = 0^\circ$	-0.03	0.585	+0.03	-	
		$y_R$			0.364		-	
	Green	$x_G$			0.350		-	
		$y_G$			0.580		-	
	Blue	$x_B$			0.163		-	
		$y_B$			0.143		-	
Gamut					45		%	
Response Time (Rising + Falling)		$T_{RT}$	$T_a = 25^\circ\text{C}$ $\theta = 0^\circ$	-	30	35	ms	Note 6
Cross Talk		CT	$\theta = 0^\circ$	-	-	2.0	%	Note 7

<b>BOE</b>	<b>PRODUCT GROUP</b>	REV	ISSUE DATE
	TFT- LCD PRODUCT	P1	2016.03.23
SPEC. NUMBER	SPEC. TITLE NV156FHM-N35 Preliminary Product Specification	PAGE 11 OF 33	

Notes :

1. Viewing angle is the angle at which the contrast ratio is greater than 10. The viewing angles are determined for the horizontal or 3, 9 o'clock direction and the vertical or 6, 12 o'clock direction with respect to the optical axis which is normal to the LCD surface (see FIGURE 1).

2. Contrast measurements shall be made at viewing angle of  $\Theta = 0$  and at the center of the LCD surface. Luminance shall be measured with all pixels in the view field set first to white, then to the dark (black) state .

(see FIGURE 1) Luminance Contrast Ratio (CR) is defined mathematically.

$$CR = \frac{\text{Luminance when displaying a white raster}}{\text{Luminance when displaying a black raster}}$$

3. Center Luminance of white is defined as luminance values of 5 point average across the LCD surface. Luminance shall be measured with all pixels in the view field set first to white. This measurement shall be taken at the locations shown in FIGURE 2 for a total of the measurements per display.

4. The White luminance uniformity on LCD surface is then expressed as :  $\Delta Y = \text{Minimum Luminance of 5(or 13) points} / \text{Maximum Luminance of 5(or 13) points}$ . (see FIGURE 2 and FIGURE 3).

5. The color chromaticity coordinates specified in Table 5 shall be calculated from the spectral data measured with all pixels first in red, green, blue and white. Measurements shall be made at the center of the panel.

6. The electro-optical response time measurements shall be made as FIGURE 4 by switching the "data" input signal ON and OFF. The times needed for the luminance to change from 10% to 90% is  $T_r$ , and 90% to 10% is  $T_d$ .

7. Cross-Talk of one area of the LCD surface by another shall be measured by comparing the luminance (YA) of a 25mm diameter area, with all display pixels set to a gray level, to the luminance (YB) of that same area when any adjacent area is driven dark. (See FIGURE 5).

<b>BOE</b>	<b>PRODUCT GROUP</b>	REV	ISSUE DATE
	TFT- LCD PRODUCT	P1	2016.03.23
SPEC. NUMBER	SPEC. TITLE NV156FHM-N35 Preliminary Product Specification		PAGE 12 OF 33

### 4.3 Optical measurements

**Figure 1. Measurement Set Up**

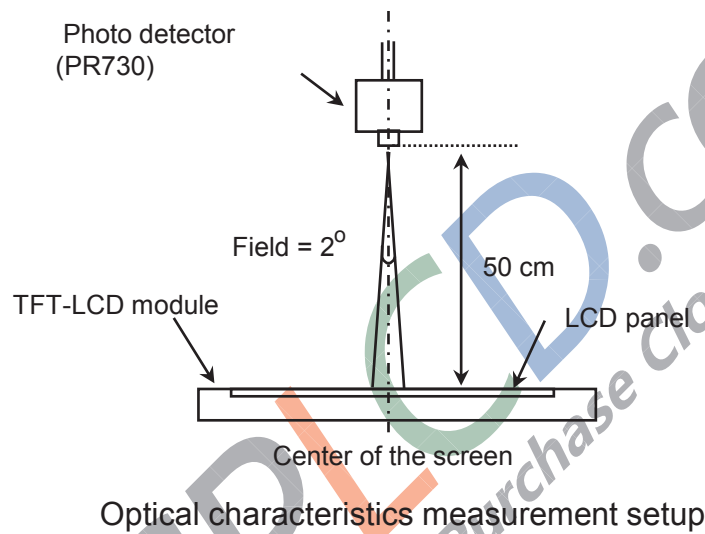

**Figure 2. White Luminance and Uniformity Measurement Locations (5 points)**

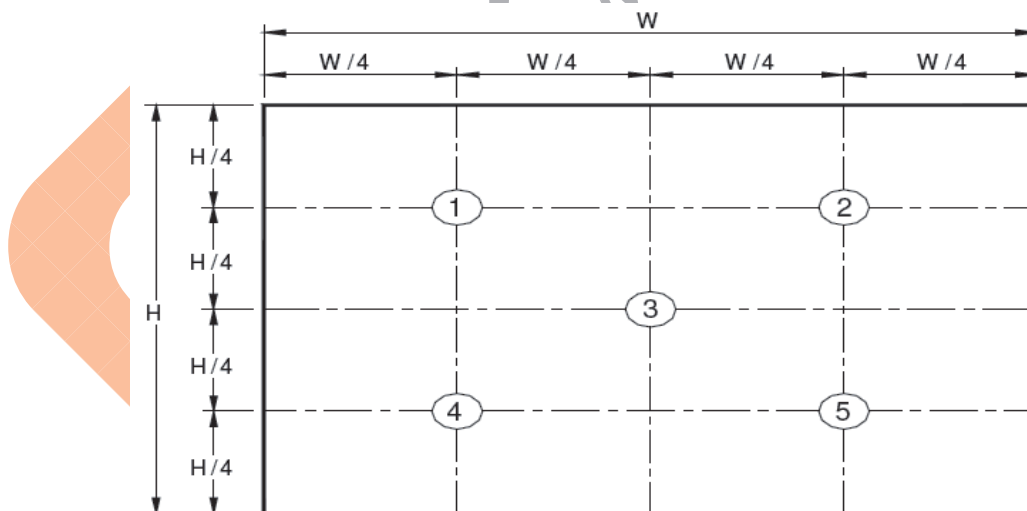

Center Luminance of white is defined as luminance values of center 5 points across the LCD surface. Luminance shall be measured with all pixels in the view field set first to white. This measurement shall be taken at the locations shown in FIGURE 2 for a total of the measurements per display.

<b>BOE</b>	<b>PRODUCT GROUP</b>	REV	ISSUE DATE
	TFT- LCD PRODUCT	P1	2016.03.23
SPEC. NUMBER	SPEC. TITLE NV156FHM-N35 Preliminary Product Specification		PAGE 13 OF 33

**Figure 3. Uniformity Measurement Locations (13 points)**

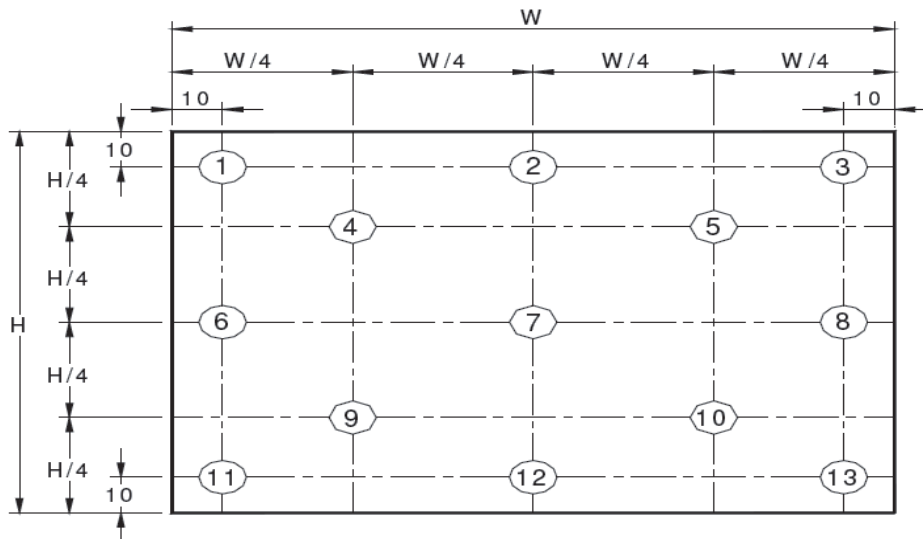

The White luminance uniformity on LCD surface is then expressed as :  $\Delta Y_5 = \text{Minimum Luminance of five points} / \text{Maximum Luminance of five points}$  (see FIGURE 2) ,  $\Delta Y_{13} = \text{Minimum Luminance of 13 points} / \text{Maximum Luminance of 13 points}$  (see FIGURE 3).

**Figure 4. Response Time Testing**

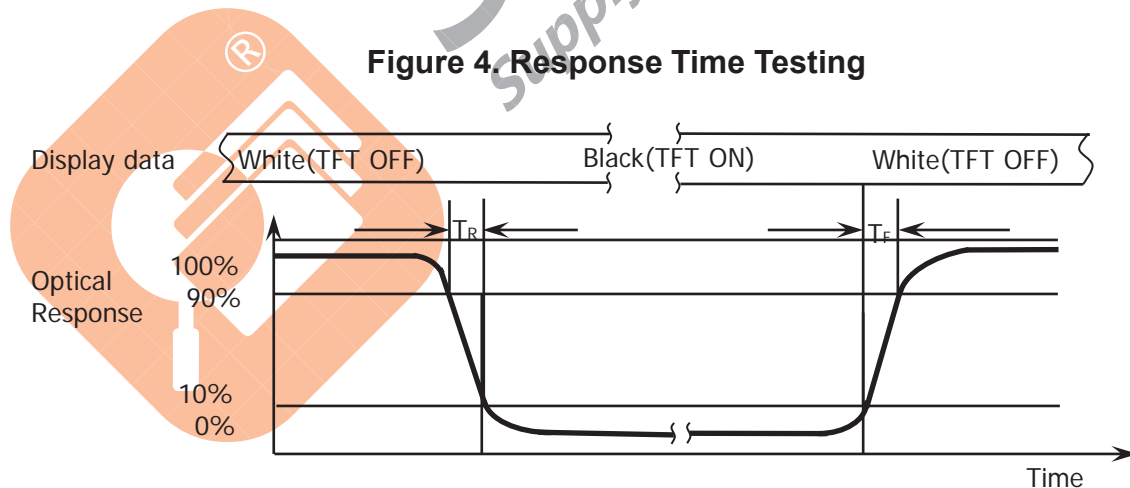

The electro-optical response time measurements shall be made as shown in FIGURE 4 by switching the “data” input signal ON and OFF. The times needed for the luminance to change from 10% to 90% is  $T_d$  and 90% to 10% is  $T_r$ .

<b>BOE</b>	<b>PRODUCT GROUP</b>	REV	ISSUE DATE
	TFT- LCD PRODUCT	P1	2016.03.23
SPEC. NUMBER	SPEC. TITLE NV156FHM-N35 Preliminary Product Specification	PAGE 14 OF 33	

**Figure 5. Cross Modulation Test Description**

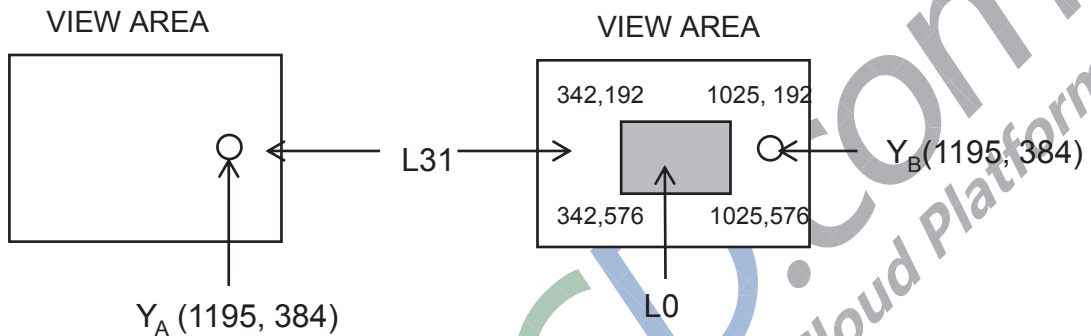

$$\text{Cross-Talk (\%)} = \left| \frac{Y_B - Y_A}{Y_A} \right| \times 100$$

Where:

$Y_A$  = Initial luminance of measured area (cd/m<sup>2</sup>)

$Y_B$  = Subsequent luminance of measured area (cd/m<sup>2</sup>)

The location measured will be exactly the same in both patterns

Cross-Talk of one area of the LCD surface by another shall be measured by comparing the luminance ( $Y_A$ ) of a 25mm diameter area, with all display pixels set to a gray level, to the luminance ( $Y_B$ ) of that same area when any adjacent area is driven dark (Refer to FIGURE 5).

<b>BOE</b>	<b>PRODUCT GROUP</b>	REV	ISSUE DATE
	TFT- LCD PRODUCT	P1	2016.03.23
SPEC. NUMBER	SPEC. TITLE NV156FHM-N35 Preliminary Product Specification	PAGE 15 OF 33	

## 5.0 INTERFACE CONNECTION.

### 5.1 Electrical Interface Connection

The electronics interface connector is STM MSAK24025P30 or Compatible.  
The connector interface pin assignments are listed in Table 6.

<Table 6. Pin Assignments for the Interface Connector>

<b>Terminal</b>	<b>Symbol</b>	<b>Functions</b>
Pin No.	Symbol	Description
1	CABC_ENABLE	CABC_Function Reserved
2	H_GND	Ground
3	LANE1_N	eDP RX channel 1 negative
4	LANE1_P	eDP RX channel 1 positive
5	H_GND	Ground
6	LANE0_N	eDP RX channel 0 negative
7	LANE0_P	eDP RX channel 0 positive
8	H_GND	Ground
9	AUX_CH_P	eDP AUX CH positive
10	AUX_CH_N	eDP AUX CH negative
11	H_GND	Ground
12	LCD_VCC	Power Supply, 3.3V (typ.)
13	LCD_VCC	Power Supply, 3.3V (typ.)
14	LCD_Self_Test	Panel self test enable
15	H_GND	Ground
16	H_GND	Ground
17	HPD	Hot plug detect output
18	BL_GND	LED Ground
19	BL_GND	LED Ground
20	BL_GND	LED Ground
21	BL_GND	LED Ground
22	BL_ENABLE	LED enable pin(+3.3V Input)
23	BL_PWM	System PWM Signal Input
24	NC	No Connection
25	COLOR_ENIN	Color Engin Function Reserved
26	BL_POWER	LED Power Supply 5V-21V
27	BL_POWER	LED Power Supply 5V-21V
28	BL_POWER	LED Power Supply 5V-21V
29	BL_POWER	LED Power Supply 5V-21V
30	NC	No Connection

<b>BOE</b>	<b>PRODUCT GROUP</b>	REV	ISSUE DATE
	TFT- LCD PRODUCT	P1	2016.03.23
SPEC. NUMBER	SPEC. TITLE NV156FHM-N35 Preliminary Product Specification		PAGE 16 OF 33

### 5-2. eDP Interface

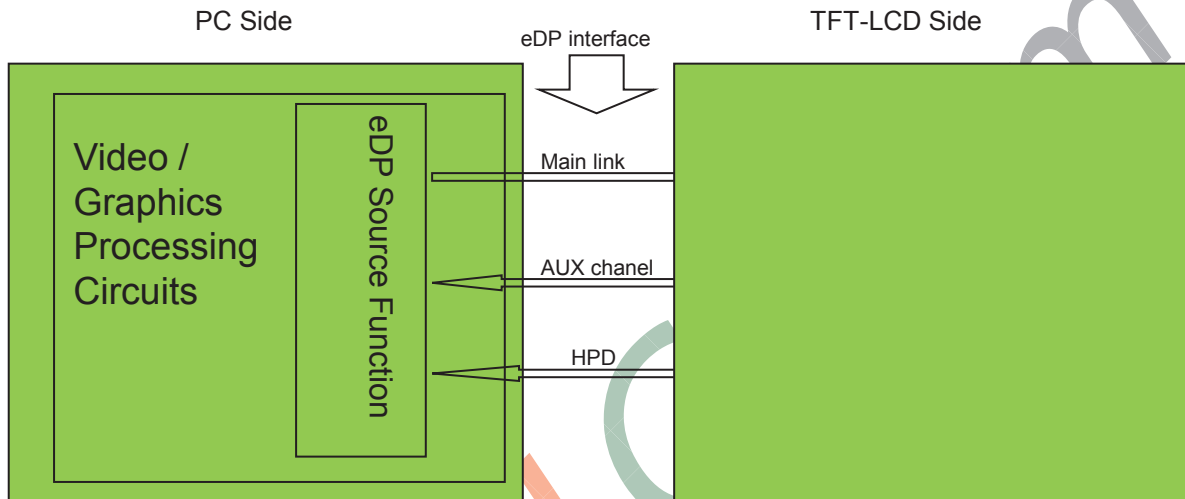

Note. Transmitter : Parade DP501 or equivalent.  
Transmitter is not contained in Module.

### 5.3.eDP Input signal

<b>Lane 0</b>	<b>Lane 1</b>
R0-5:0 G0-5:4	R1-5:0 G1-5:4
G0-3:0 B0-5:2	G1-3:0 B1-5:2
B0-1:0 R2-5:0	B1-1:0 R3-5:0
G2-5:0 B2-5:4	G3-5:0 B3-5:4
B2-3:0 R4-5:2	B3-3:0 R5-5:2
R4-1:0 G4-5:0	R5-1:0 G5-5:0
B4-5:0 R6-5:4	B5-5:0 R7-5:4
R6-3:0 G6-5:2	R7-3:0 G7-5:2
G6-1:0 B6-5:0	G7-1:0 B7-5:0



<b>BOE</b>	<b>PRODUCT GROUP</b>	REV	ISSUE DATE
	TFT- LCD PRODUCT	P1	2016.03.23
SPEC. NUMBER	SPEC. TITLE NV156FHM-N35 Preliminary Product Specification		PAGE 17 OF 33

#### 5.4 Back-light & LCM Interface Connection

Interface Connector: **STM MSK24022P10 or compatible**

<Table 7. Pin Assignments for the BLU & LCM Connector>

Pin No.	Symbol	Description	Pin No.	Symbol	Description
1	LED1	LED anode connection	6	GND	Ground
2	LED2	LED anode connection	7	NC	No Connection
3	LED3	LED anode connection	8	Vout	LED cathode connection
4	LED4	LED anode connection	9	Vout	LED cathode connection
5	NC	No Connection	10	Vout	LED cathode connection



SPLCD.com  
Supply & Purchase Cloud Platform

<b>BOE</b>	<b>PRODUCT GROUP</b>	REV	ISSUE DATE
	TFT- LCD PRODUCT	P1	2016.03.23
SPEC. NUMBER	SPEC. TITLE NV156FHM-N35 Preliminary Product Specification		PAGE 18 OF 33

## 6.0 SIGNAL TIMING SPECIFICATION

6.1 The NV156FHM-N35 is operated by the DE only.

Item		Symbols	Min	Typ	Max	Unit
Clock	Frequency	1/Tc	122	152.6	158	MHz
	High Time	Tch	-	4/7	-	Tc
	Low Time	Tcl	-	3/7	-	Tc
Frame Period		Tv	1090	1140	1200	lines
			-	60	-	Hz
			-	16.7	-	ms
Vertical Display Period		Tvd	-	1080	-	lines
One line Scanning Period		Th	2080	2230	2400	clocks
Horizontal Display Period		Thd	-	1920	-	clocks

Note\*: This Module can support low frame refresh rate 48Hz.

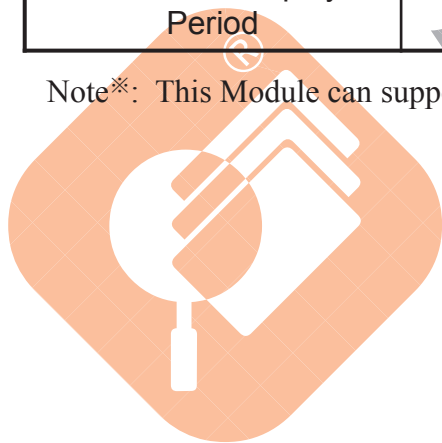

### 6.2 eDP Rx Interface Timing Parameter

The specification of the eDP Rx interface timing parameter is shown in Table 8.

<Table 8. eDP Rx Interface Timing Specification>

Item	Symbol	Min	Typ	Max	Unit	Remark
Spread spectrum clock	ssc		0.5		%	
Differential peak-to-peak input voltage at package pins	VRX-DIFFp-p	120		1200	mV	
Rx input DC common mode voltage	VRX_DC_CM	-	GND	-	V	
Differential termination resistance	RRX-DIFF	80	-	100	$\Omega$	
Single-ended termination resistance	RRX-SE	40	-	60	$\Omega$	
Rx short circuit current limit	IRX_SHORT	-	-	20	mA	
Intra-pair skew at Rx package pins (HBR) RX intra-pair skew tolerance at HBR	LRX_SKEW_INTRA_PAIR	-	-	150	ps	

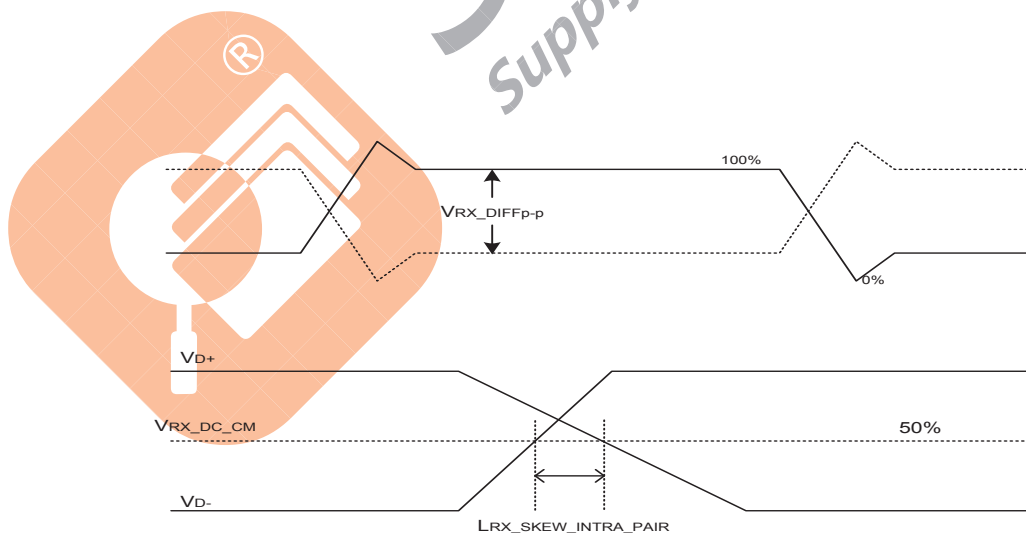



PRODUCT GROUP

REV

ISSUE DATE

TFT- LCD PRODUCT

P1

2016.03.23

SPEC. NUMBER

SPEC. TITLE

PAGE

NV156FHM-N35 Preliminary Product Specification

20 OF 33

7.0 INPUT SIGNALS, BASIC DISPLAY COLORS & GRAY SCALE OF COLORS

	Colors & Gray scale	Data signal																	
		R0	R1	R2	R3	R4	R5	G0	G1	G2	G3	G4	G5	B0	B1	B2	B3	B4	B5
Basic colors	Black	0	0	0	0	0	0	0	0	0	0	0	0	0	0	0	0	0	0
	Blue	0	0	0	0	0	0	0	0	0	0	0	0	1	1	1	1	1	1
	Green	0	0	0	0	0	0	1	1	1	1	1	1	0	0	0	0	0	0
	Light Blue	0	0	0	0	0	0	1	1	1	1	1	1	1	1	1	1	1	1
	Red	1	1	1	1	1	1	0	0	0	0	0	0	0	0	0	0	0	0
	Purple	1	1	1	1	1	1	0	0	0	0	0	0	1	1	1	1	1	1
	Yellow	1	1	1	1	1	1	1	1	1	1	1	1	0	0	0	0	0	0
	White	1	1	1	1	1	1	1	1	1	1	1	1	1	1	1	1	1	1
Gray scale of Red	Black	0	0	0	0	0	0	0	0	0	0	0	0	0	0	0	0	0	0
	△	1	0	0	0	0	0	0	0	0	0	0	0	0	0	0	0	0	0
	Darker	0	1	0	0	0	0	0	0	0	0	0	0	0	0	0	0	0	0
	△				↑						↑						↑		
	▽				↓						↓						↓		
	Brighter	1	0	1	1	1	1	0	0	0	0	0	0	0	0	0	0	0	0
Gray scale of Green	Black	0	0	0	0	0	0	0	0	0	0	0	0	0	0	0	0	0	0
	△	0	0	0	0	0	0	1	0	0	0	0	0	0	0	0	0	0	0
	Darker	0	0	0	0	0	0	0	1	0	0	0	0	0	0	0	0	0	0
	△				↑						↑						↑		
	▽				↓						↓						↓		
	Brighter	0	0	0	0	0	0	1	0	1	1	1	1	0	0	0	0	0	0
Gray scale of Blue	Black	0	0	0	0	0	0	0	0	0	0	0	0	0	0	0	0	0	0
	△	0	0	0	0	0	0	0	0	0	0	0	0	1	0	0	0	0	0
	Darker	0	0	0	0	0	0	0	0	0	0	0	0	0	1	0	0	0	0
	△				↑						↑						↑		
	▽				↓						↓						↓		
	Brighter	0	0	0	0	0	0	0	0	0	0	0	0	1	0	1	1	1	1
Gray scale of White & Black	Black	0	0	0	0	0	0	0	0	0	0	0	0	0	0	0	0	0	0
	△	1	0	0	0	0	0	1	0	0	0	0	0	1	0	0	0	0	0
	Darker	0	1	0	0	0	0	0	1	0	0	0	0	0	1	0	0	0	0
	△				↑						↑						↑		
	▽				↓						↓						↓		
	Brighter	1	0	1	1	1	1	1	0	1	1	1	1	1	0	1	1	1	1
White	1	1	1	1	1	1	1	1	1	1	1	1	1	1	1	1	1	1	

### 8.0 POWER SEQUENCE

To prevent a latch-up or DC operation of the LCD module, the power on/off sequence shall be as shown in below

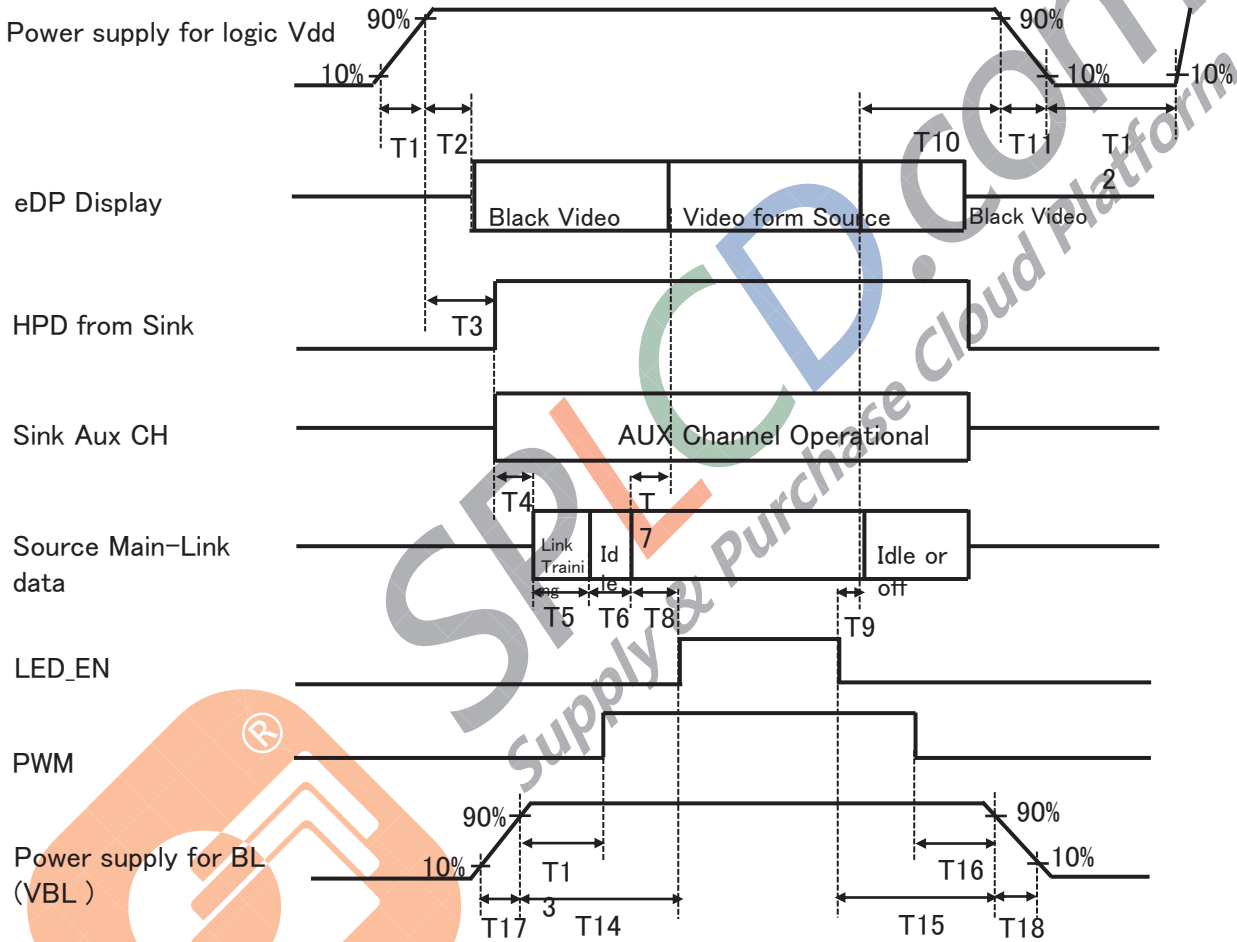

- 0.5ms ≤ T1 ≤ 10 ms
- 0ms ≤ T2 ≤ 200 ms
- 0ms ≤ T3 ≤ 200 ms
- 0ms ≤ T13
- 0ms ≤ T14
- 0ms ≤ T17
- 0ms ≤ T7 ≤ 50ms
- 0ms ≤ T10 ≤ 500 ms
- 0ms ≤ T11 ≤ 10 ms
- 150ms ≤ T12
- 0ms ≤ T15
- 0ms ≤ T16
- 0ms ≤ T18

**Notes:**

- When the power supply VDD is 0V, keep the level of input signals on the low or keep high impedance.
- Do not keep the interface signal high impedance when power is on. Back Light must be turn on after power for logic and interface signal are valid.

<b>BOE</b>	<b>PRODUCT GROUP</b>	REV	ISSUE DATE
	TFT- LCD PRODUCT	P1	2016.03.23
SPEC. NUMBER	SPEC. TITLE NV156FHM-N35 Preliminary Product Specification		PAGE 22 OF 33

## 9.0 Connector Description

Physical interface is described as for the connector on LCM.

These connectors are capable of accommodating the following signals and will be following components.

### 9.1 TFT LCD Module

Connector Name /Description	For Signal Connector
Manufacturer	STM or Compatible
Type/ Part Number	MSAK24025P30 or Compatible
Mating housing/ Part Number	I-PEX 20454-030T or Compatible



SPLCD.com  
Supply & Purchase Cloud Platform

<b>BOE</b>	<b>PRODUCT GROUP</b>	REV	ISSUE DATE
	TFT- LCD PRODUCT	P1	2016.03.23
SPEC. NUMBER	SPEC. TITLE NV156FHM-N35 Preliminary Product Specification	PAGE 23 OF 33	

## 10.0 MECHANICAL CHARACTERISTICS

### 10.1 Dimensional Requirements

FIGURE 6 shows mechanical outlines for the model NV156FHM-N35. Other parameters are shown in Table 9.

<Table 9. Dimensional Parameters>

Parameter	Specification	Unit
Active Area	344.16 (H) × 193.59(V)	
Number of pixels	1920 (H) X 1080 (V) (1 pixel = R + G + B dots)	
Pixel pitch	0.17925 (H) X 0.17925 (V)	mm
Pixel arrangement	RGB Vertical stripe	
Display colors	262K	
Display mode	Normally Black	
Dimensional outline	350.76(H)*216.195(V) (W/PCB)*3.2(Max)	mm
Weight	380(Max)	gram
Back Light	Connector :STM MSK24022P10D or Compatible LED, Horizontal-LED Array type	

### 10.2 Mounting

See FIGURE 6.

### 10.3 Glare and Polarizer Hardness.

The surface of the LCD has an glare coating to maximize readability and hard coating to reduce scratching.

### 10.4 Light Leakage

There shall not be visible light from the back-lighting system around the edges of the screen as seen from a distance 50cm from the screen with an overhead light level of 350lux.

<b>BOE</b>	<b>PRODUCT GROUP</b>	REV	ISSUE DATE
	TFT- LCD PRODUCT	P1	2016.03.23
SPEC. NUMBER	SPEC. TITLE NV156FHM-N35 Preliminary Product Specification		PAGE 24 OF 33

## 11.0 RELIABILITY TEST

The Reliability test items and its conditions are shown in below.

<Table 10. Reliability test>

No	Test Items	Conditions
1	High temperature storage test	Ta = 60 °C, 240 hrs
2	Low temperature storage test	Ta = -20 °C, 240 hrs
3	High temperature & high humidity operation test	Ta = 50 °C, 80%RH, 240 hrs
4	High temperature operation test	Ta = 50 °C, 240 hrs
5	Low temperature operation test	Ta = 0 °C, 240 hrs
6	Thermal shock	Ta = -20 °C ↔ 60 °C (0.5 hr), 100 cycle
7	Vibration test (non-operating)	1.5G, 10~500Hz, Half Sine X, Y, Z / Sweep rate : 1 hour
8	Shock test (non-operating)	220G, Half Sine Wave 2msec ±X, ±Y, ±Z Once for each direction
9	Electro-static discharge test (non-operating)	Air : 150 pF, 330Ω, 15 KV Contact : 150 pF, 330Ω, 8 KV

## 12.0 HANDLING & CAUTIONS

### (1) Cautions when taking out the module

- Pick the pouch only, when taking out module from a shipping package.

### (2) Cautions for handling the module

- As the electrostatic discharges may break the LCD module, handle the LCD module with care. Peel a protection sheet off from the LCD panel surface as slowly as possible.
- As the LCD panel and back - light element are made from fragile glass material, impulse and pressure to the LCD module should be avoided.
- As the surface of the polarizer is very soft and easily scratched, use a soft dry cloth without chemicals for cleaning.
- Do not pull the interface connector in or out while the LCD module is operating.
- Put the module display side down on a flat horizontal plane.
- Handle connectors and cables with care.

### (3) Cautions for the operation

- When the module is operating, do not lose CLK, ENAB signals. If any one of these signals is lost, the LCD panel would be damaged.
- Obey the supply voltage sequence. If wrong sequence is applied, the module would be damaged.



<b>BOE</b>	<b>PRODUCT GROUP</b>	REV	ISSUE DATE
	TFT- LCD PRODUCT	P1	2016.03.23
SPEC. NUMBER	SPEC. TITLE NV156FHM-N35 Preliminary Product Specification		PAGE 25 OF 33

(4) Cautions for the atmosphere

- Dew drop atmosphere should be avoided.
- Do not store and/or operate the LCD module in a high temperature and/or humidity atmosphere. Storage in an electro-conductive polymer packing pouch and under relatively low temperature atmosphere is recommended.

(5) Cautions for the module characteristics

- Do not apply fixed pattern data signal to the LCD module at product aging.
- Applying fixed pattern for a long time may cause image sticking.

(6) Other cautions

- Do not disassemble and/or re-assemble LCD module.
- Do not re-adjust variable resistor or switch etc.
- When returning the module for repair or etc., Please pack the module not to be broken. We recommend to use the original shipping packages.

**13.0 LABEL**

(1) MDL label

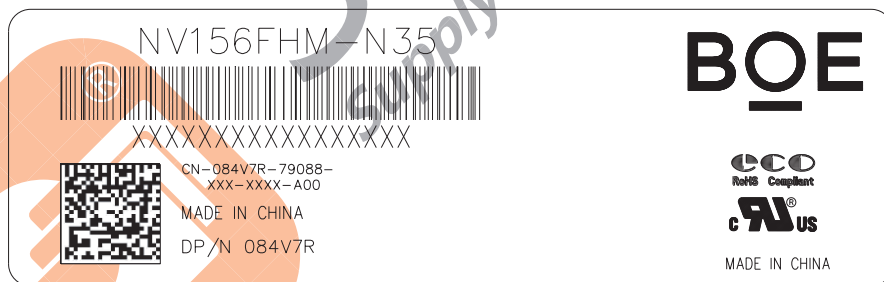

Digit	1	2	3	4	5	6	7	8	9	10	11	12	13	14	15	16	17
Code	S	L	S	5	1	2	3	5	9	4	2	0	0	0	1	D	B
Description	Model Code /GBN		Grade	Line	Year		Month	Model Extension Code (Last 4 Digits Of FG COD)				Serial No 00001-ZZZZZZ					

<b>BOE</b>	<b>PRODUCT GROUP</b>	REV	ISSUE DATE
	TFT- LCD PRODUCT	P1	2016.03.23
SPEC. NUMBER	SPEC. TITLE NV156FHM-N35 Preliminary Product Specification	PAGE 26 OF 33	

(2) High voltage caution label

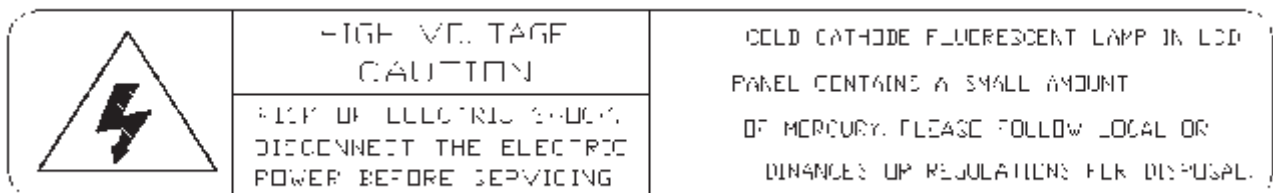

(3) Box label

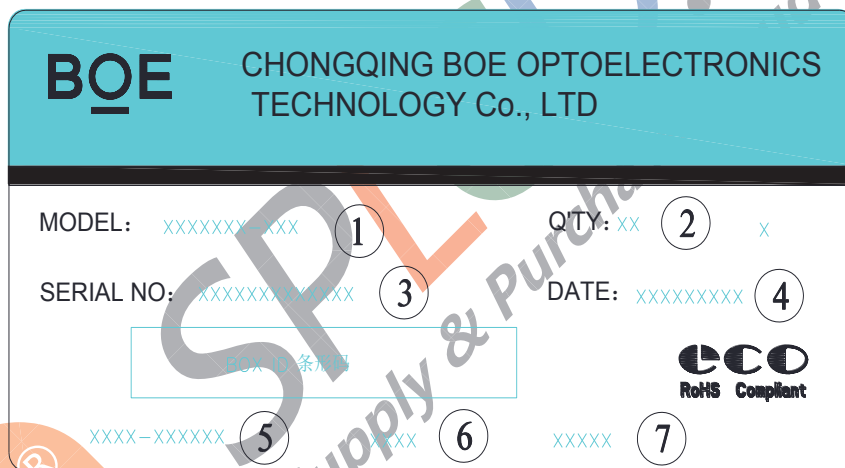

序列号标注部分需打印, 说明如下:

1. **FG-CODE**(前12位)
2. 产品数量
3. **Box ID**
4. 包装日期
5. 客户端段物料号(客户端)---暂不打印,预留空间
6. FG-Code后四位
7. 供应商代码 ---暂不打印

**Total Size:110×55mm**

Code \ Digit	1	2	3	4	5	6	7	8	9	10	11	12	13
<b>Code</b>	S	L	S	F	1	2	3	D	0	0	0	6	8
<b>Description</b>	Products GBN		Grade	Line	Year		Month	Revision Code	Serial No				

<b>BOE</b>	<b>PRODUCT GROUP</b>	REV	ISSUE DATE
	TFT- LCD PRODUCT	P1	2016.03.23
SPEC. NUMBER	SPEC. TITLE NV156FHM-N35 Preliminary Product Specification	PAGE 27 OF 33	

## 15.0 PACKING INFORMATION

### 15.1 Packing order

- Put Pad into the inner box

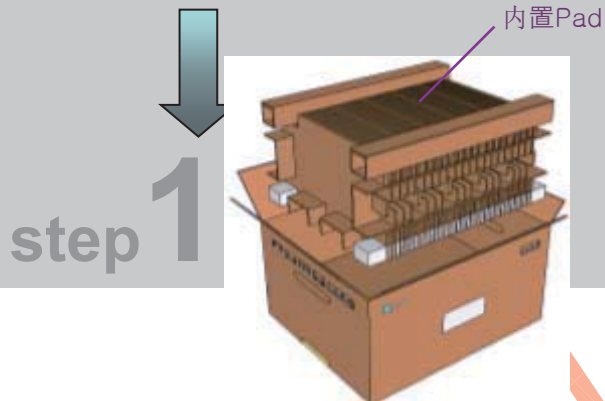

- Put module into the paper spacer and modules bundled by PE Bag

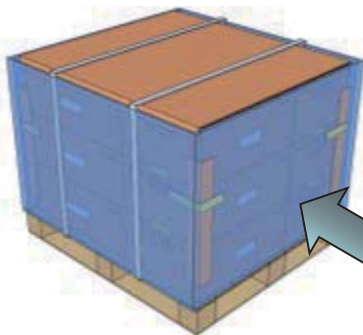
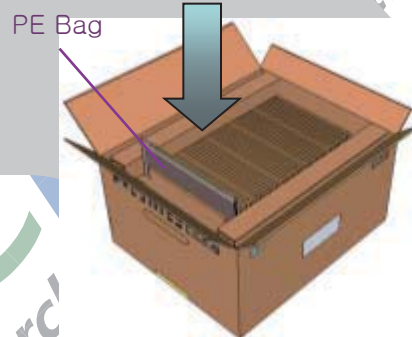

step 4



- Put Cover on the top of the pad

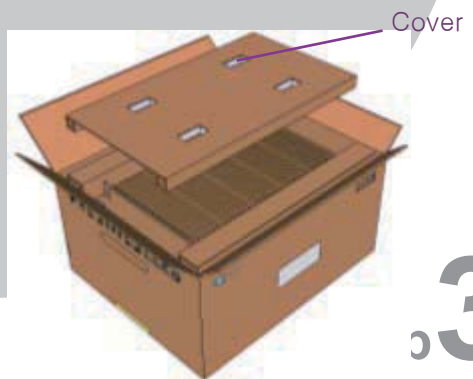

- 12ea Box/Pallet, 456ea MDL/Pallet

### 15.2 Notes

- Box Dimension: 580mm×488mm×303mm
- Package Quantity in one Box:38 pcs
- Total Weight: 19.3kg/Box



<b>BOE</b>	PRODUCT GROUP	REV	ISSUE DATE
	TFT- LCD PRODUCT	P1	2016.03.23
SPEC. NUMBER	SPEC. TITLE NV156FHM-N35 Preliminary Product Specification	PAGE 29 OF 33	

Figure 7. TFT-LCD Module Outline Dimensions (Rear view)

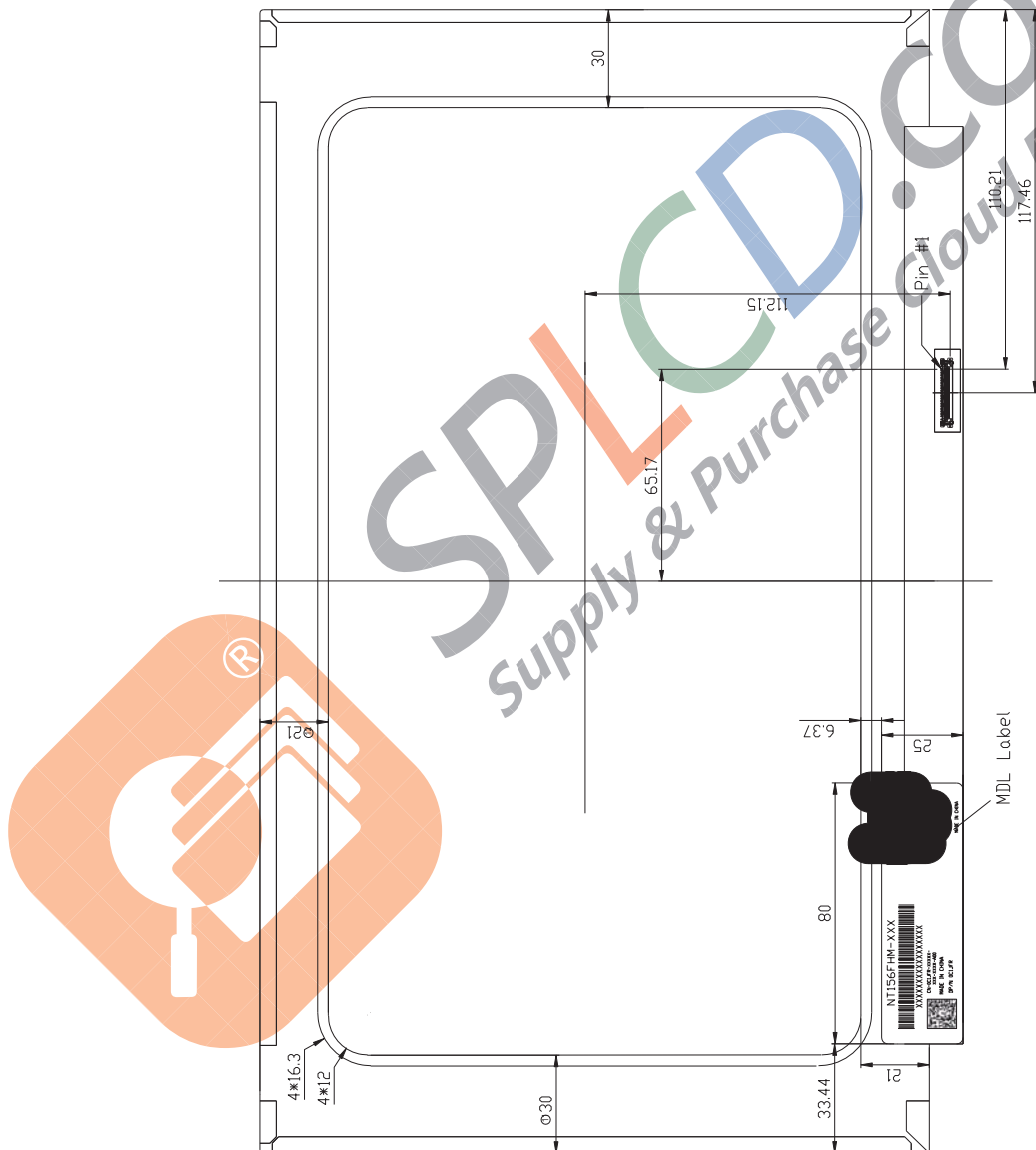



# PRODUCT GROUP

REV

ISSUE DATE

TFT- LCD PRODUCT

P1

2016.03.23

SPEC. NUMBER

SPEC. TITLE

NV156FHM-N35 Preliminary Product Specification

PAGE

30 OF 33

## 17.0 EDID Table

Address (HEX)	Function	Hex	Dec	Input values.	Notes
00	Header	00	0	0	EDID Header
01		FF	255	255	
02		FF	255	255	
03		FF	255	255	
04		FF	255	255	
05		FF	255	255	
06		FF	255	255	
07		00	0	0	
08	ID Manufacturer Name	09	9	BOE	ID = BOE
09		E5	229		
0A	ID Product Code	B4	180	1716	ID = 1716
0B		06	6		
0C	32-bit serial No.	00	0		
0D		00	0		
0E		00	0		
0F		00	0		
10	Week of manufacture	01	1	1	
11	Year of Manufacture	1A	26	2016	Manufactured in 2016
12	EDID Structure Ver.	01	1	1	EDID Ver 1.0
13	EDID revision #	04	4	4	EDID Rev. 0.4
14	Video input definition	95	149	-	digital signal/DP input
15	Max H image size	22	34	34	34 cm (Approx)
16	Max V image size	13	19	19	19 cm (Approx)
17	Display Gamma	78	120	2.2	Gamma curve = 2.2
18	Feature support	0A	10		RGB display, Preferred Timing mode
19	Red/Green low bits	C9	201	-	Red / Green Low Bits
1A	Blue/White low bits	A0	160	-	Blue / White Low Bits
1B	Red x high bits	95	149	0.585	Red (x) = 10010101 (0.585)
1C	Red y high bits	5D	93	0.364	Red (y) = 01011101 (0.364)
1D	Green x high bits	59	89	0.350	Green (x) = 01011001 (0.35)
1E	Green y high bits	94	148	0.580	Green (y) = 10010100 (0.58)
1F	Blue x high bits	29	41	0.163	Blue (x) = 00101001 (0.163)
20	BLue y high bits	24	36	0.143	Blue (y) = 00100100 (0.143)
21	White x high bits	50	80	0.313	White (x) = 01010000 (0.313)
22	White y high bits	54	84	0.329	White (y) = 01010100 (0.329)
23	Established timing 1	00	0	-	
24	Established timing 2	00	0	-	

25	Established timing 3	00	0	-	
26	Standard timing #1	01	1		Not Used
27		01	1		
28	Standard timing #2	01	1		Not Used
29		01	1		
2A	Standard timing #3	01	1		Not Used
2B		01	1		
2C	Standard timing #4	01	1		Not Used
2D		01	1		
2E	Standard timing #5	01	1		Not Used
2F		01	1		
30	Standard timing #6	01	1		Not Used
31		01	1		
32	Standard timing #7	01	1		Not Used
33		01	1		
34	Standard timing #8	01	1		Not Used
35		01	1		
36	Detailed timing/monitor descriptor #1	9C	156	152.6	152.6MHz Main clock
37		3B	59		
38		80	128	1920	Hor Active = 1920
39		36	54	310	Hor Blanking = 310
3A		71	113	-	4 bits of Hor. Active + 4 bits of Hor. Blanking
3B		38	56	1080	Ver Active = 1080
3C		3C	60	60	Ver Blanking = 60
3D		40	64	-	4 bits of Ver. Active + 4 bits of Ver. Blanking
3E		30	48	48	Hor Sync Offset = 48
3F		20	32	32	H Sync Pulse Width = 32
40		36	54	3	V sync Offset = 3 line
41		00	0	6	V Sync Pulse width : 6 line
42		58	88	344	Horizontal Image Size = 344 mm (Low 8 bits)
43		C2	194	194	Vertical Image Size = 194 mm (Low 8 bits)
44		10	16	-	4 bits of Hor Image Size + 4 bits of Ver Image Size
45	00	0	0	Hor Border (pixels)	
46	00	0	0	Vertical Border (Lines)	
47	1A	26		Refer to right table	



PRODUCT GROUP

REV

ISSUE DATE

TFT- LCD PRODUCT

P1

2016.03.23

SPEC. NUMBER

SPEC. TITLE

NV156FHM-N35 Preliminary Product Specification

PAGE

32 OF 33

48	Detailed timing/monitor descriptor #2	FD	253	117.7	117.73MHz Main clock
49		2D	45		
4A		80	128	1920	Hor Active = 1920
4B		0E	14	270	Hor Blanking = 270
4C		71	113	-	4 bits of Hor. Active + 4 bits of Hor. Blanking
4D		38	56	1080	Ver Active = 1080
4E		28	40	40	Ver Blanking = 40
4F		40	64	-	4 bits of Ver. Active + 4 bits of Ver. Blanking
50		30	48	48	Hor Sync Offset = 48
51		20	32	32	H Sync Pulse Width = 32
52		36	54	3	V sync Offset = 3 line
53		00	0	6	V Sync Pulse width : 6 line
54		58	88	344	Horizontal Image Size = 344 mm (Low 8 bits)
55		C2	194	194	Vertical Image Size = 194 mm (Low 8 bits)
56		10	16	-	4 bits of Hor Image Size + 4 bits of Ver Image Size
57		00	0	0	Hor Border (pixels)
58		00	0	0	Vertical Border (Lines)
59		1A	26		
5A		00	0		ASCII Data Sting Tag
5B	00	0			
5C	00	0			
5D	FE	254			
5E	00	0			
5F	38	56	8	D/PN:84V7R	
60	34	52	4		
61	56	86	V		
62	37	55	7		
63	52	82	R		
64	<b>80</b>	<b>128</b>	10000000	<b>EDID:A00</b>	
65	4E	78	N	BOE PN:NV15 N35	
66	56	86	V		
67	31	49	1		
68	35	53	5		
69	4E	78	N		
6A	33	51	3		
6B	35	53	5		



6C	Detailed timing/monitor descriptor #4	00	0		Product Name Tag (ASCII)
6D		00	0		
6E		00	0		
6F		00	0		
70		00	0		
71		00	0	00000000	6-bit Color Depth & no FRC
72		41	65	01000001	WLED & singal light bar & one light bar
73		22	34	00100010	Frame rate 48Hz~65Hz
74		96	150	10010110	Light Controller:PWM & Max. Luminance 220
75		01	1	00000001	Front Surface: AG & RGB v-stripe
76	10	16	00010000	NTSC & DBC	
77	00	0	00000000	no Motion Blur & no Active Gamma	
78	00	0	00000000	no Wireless Enhancement & no In-Cell Scanner	
79	0A	10	00001010	2 lane edp1.2	
7A	01	1	00000001	Built-In Self Test	
7B	0A	10			
7C	20	32			
7D	20	32			
7E	Extension flag	00	0		
7F	Checksum	B2	178	-	

