



九齊科技股份有限公司
Nyquest Technology Co., Ltd.

DATA SHEET

NY7BxxxA Series

**Single-Chip 4-bit MCU with 16 I/O
& 8-CH Speech/MIDI**

Version 1.2

Aug. 27, 2014

NYQUEST TECHNOLOGY CO. reserves the right to change this document without prior notice. Information provided by NYQUEST is believed to be accurate and reliable. However, NYQUEST makes no warranty for any errors which may appear in this document. Contact NYQUEST to obtain the latest version of device specifications before placing your orders. No responsibility is assumed by NYQUEST for any infringement of patent or other rights of third parties which may result from its use. In addition, NYQUEST products are not authorized for use as critical components in life support devices/systems or aviation devices/systems, where a malfunction or failure of the product may reasonably be expected to result in significant injury to the user, without the express written approval of NYQUEST.

Revision History

Version	Date	Description	Modified Page
1.0	2013/06/28	Formal release.	--
1.1	2013/08/13	<ol style="list-style-type: none">1. Add 4 mask options for Push-Pull analog volume adjustment.2. Revise the description of <i>Chapter 9.1 Speech Synthesis</i>.	4, 6, 10 10
1.2	2014/08/27	Modify DC Characteristics.	12

1. 概述

NY7BxxxA系列產品為多功能單晶片CMOS語音合成4位元微控制器，提供8通道的語音/MIDI合成功能，所有的通道或部分的通道可同時播放語音或MIDI。語音和MIDI音色的合成方式都可採用高保真度的6-bit ADPCM演算法，最高採樣率可達44.1KHz，可提供接近CD的音質。NY7B是特別設計用來做MIDI合成應用，除了提供256階ADSR包絡(Attack-Decay-Sustain-Release envelope)作為音色合成，還加上精準的 $\pm 0.5\%$ 內阻震盪與內建的硬體自動調音功能。因此，NY7B能準確地合成MIDI音符，讓音效逼近真實樂器。

NY7B內建了九齊科技最新開發的128KHz超採樣雜訊過濾演算法(Noise Filter with 128KHz Over-Sampling)，能夠有效的消除雜訊並大幅改善語音和音樂的品質，具有16階數位音量控制可以讓使用者依需求調整合成語音或音樂的音量效果。NY7B提供兩種音訊輸出方式供選擇，13-bit DAC 輸出與13-bit 推挽式 (Push-Pull, PP) 輸出。因此，NY7B語音/音樂品質是所有方案中最好的選擇。

NY7B的RISC精簡指令集架構可以很容易地做編輯和控制，共有74條指令，除了少數指令需要2個時序，大多數指令都是1個時序即能完成，可以讓使用者輕鬆地以程式控制完成不同的應用。除了一般操作模式之外，NY7B也提供待機模式(Halt mode)與慢速模式(Slow mode)，以節省功耗。

2. 功能

- 寬廣的工作電壓：2.0V ~ 5.5V。
- 4-bit RISC 精簡指令集架構的微控制器，共有74條指令。
- 共有10個母體，最大母體的ROM容量為256K x12-bit，程式和資料使用同一塊ROM。ROM容量、秒數和I/O腳數如下：

產品編號	語音長度 (秒) @6kHz	語音長度 (秒) @8KHz	ROM 容量 (bit)	程式空間 (bit)	I/O 腳數	DAC	Push-Pull
NY7B007A	7.2	5.4	24K x 12	24K x 12	16	13-bit	13-bit
NY7B010A	9.9	7.4	32K x 12	32K x 12	16	13-bit	13-bit
NY7B016A	15.4	11.5	48K x 12	48K x 12	16	13-bit	13-bit
NY7B021A	20.8	15.6	64K x 12	64K x 12	16	13-bit	13-bit
NY7B032A	31.8	23.8	96K x 12	64K x 12	16	13-bit	13-bit
NY7B043A	42.7	32.0	128K x 12	64K x 12	16	13-bit	13-bit
NY7B054A	53.6	40.2	160K x 12	64K x 12	16	13-bit	13-bit
NY7B065A	64.5	48.4	192K x 12	64K x 12	16	13-bit	13-bit
NY7B076A	75.5	56.6	224K x 12	64K x 12	16	13-bit	13-bit
NY7B087A	86.4	64.8	256K x 12	64K x 12	16	13-bit	13-bit

- 448x4-bit RAM，分成2頁，每頁224x4-bit。
- 4MHz 系統頻率。
- 提供慢速模式(Slow mode)，可降低功耗。($\pm 3\%$ 精準度)

- 提供待機模式(Halt mode)，可節省功耗，靜態電流(Isb)小於1uA。
- 內建精準的 +/- 0.5% 內阻震盪。
- 提供低壓復位(LVR=1.9V)，看門狗計時(WDT)。
- 一個中斷輸入可連結到一組獨立的堆棧(Stack)，並有多種中斷來源可以使用。
- 16根彈性的雙向I/O腳，每個I/O腳都有單獨的暫存器控制為輸入或輸出腳。
- 每個雙向I/O腳都可分別設定不同的輸入和輸出選項。針對輸入腳的三種選項：有上拉電阻的輸入腳、無上拉電阻的輸入腳、或是有暫存器控制上拉電阻的輸入腳。針對輸出腳的三種選項：有一般輸出電流 (Normal Drive Current, Normal Sink Current)、大電流的輸出腳(Large Sink Current)、或是定電流輸出(Constant Sink Current)。(光罩選擇)
- PD2/IR 腳可以當作紅外線載波輸出，PD3/Reset 腳可以當作外部復位輸入。(光罩選擇)
- 紅外線載波頻率可供選擇，同時載波之極性也可以根據數據作選擇。
- 最多可8通道同時播放，每個通道皆可任意地被指定為語音或MIDI通道。
- 提供6-bit ADPCM高音質的語音/MIDI音色合成演算法，256階ADSR包絡用於MIDI合成編輯。
- 新型專利的128KHz超採樣雜訊過濾演算法，在不增加ROM容量的前提下，可大幅加強訊噪比並提供優質聲音。
- 內建16階數位音量控制，可用於語音/音樂合成。
- 內建自動調音硬體 (Automatic Tone-Calibration)，可自動對每個音色頻率做零誤差的精準校準。
- 一組 13-bit DAC 純硬體輸出，可以外加放大線路來驅動喇叭；或一組 13-bit 推挽式(Push-Pull) 純硬體輸出，有四階類比音量光罩選項(100%, 83%, 66%, 50%)可以直接驅動喇叭。(Push-Pull 輸出功率 $P_{out}=1.3W @ V_{DD}=5V, THD+N=10\%, F=1kHz, R_L=4\Omega$.)

1. GENERAL DESCRIPTION

The NY7BxxxA series IC is a powerful 4-bit micro-controller based sound processor. There are 8 channels that are configured as speech or MIDI, and all of these 8 channels or part of them can be played with speech or MIDI simultaneously. By using the high fidelity 6-bit ADPCM synthesis algorithm for both speech and MIDI timbre with up to 44.1KHz sample rate, NY7B can produce near-CD quality voices. As NY7B is specially designated for MIDI synthesis application, it provides Attack-Decay-Sustain-Release method (ADSR) with 256-level envelope for Patch (instrument) synthesis. NY7B can precisely synthesize any tone frequency of MIDI with +/- 0.5% accurate internal oscillation and automatic Tone-Calibration. Therefore NY7B melody quality is very close to real instrument.

Moreover, NY7B is equipped with new Nyquest's developed high-quality noise filtering algorithm of 128KHz over-sampling, which can remove noise in order to improve speech and melody quality greatly. Up to 16 digital volume levels can be applied to final synthetic speech or melody that is tailored for applications of volume adjustment. NY7B provides two kinds of audio outputs with fine resolution, one is 13-bit current-type D/A converter (DAC) and the other is 13-bit Push-Pull amplifier (PP). Therefore NY7B speech/melody quality is the best choice among all solutions.

The RISC MCU architecture is very easy to program and control, various applications can be easily implemented. There are 74 instructions, and most of them are executed in single cycle. Besides normal operation mode, NY7B also provides Halt mode (or Sleep mode) and Slow mode to minimize power dissipation.

2. FEATURES

- Wide operating voltage range: 2.0V to 5.5V.
- 4-bit RISC type micro-controller with 74 instructions.
- NY7BxxxA have 10 bodies. The maximum ROM size is 256K x 12-bit. Program and voice data share the same ROM space. The voice duration, ROM size and I/O counts are shown below.

P/N	Voice Duration @6KHz (sec)	Voice Duration @8KHz (sec)	ROM Size (bit)	Program ROM Size (bit)	I/O	DAC	Push-Pull
NY7B007A	7.2	5.4	24K x 12	24K x 12	16	13-bit	13-bit
NY7B010A	9.9	7.4	32K x 12	32K x 12	16	13-bit	13-bit
NY7B016A	15.4	11.5	48K x 12	48K x 12	16	13-bit	13-bit
NY7B021A	20.8	15.6	64K x 12	64K x 12	16	13-bit	13-bit
NY7B032A	31.8	23.8	96K x 12	64K x 12	16	13-bit	13-bit
NY7B043A	42.7	32.0	128K x 12	64K x 12	16	13-bit	13-bit
NY7B054A	53.6	40.2	160K x 12	64K x 12	16	13-bit	13-bit
NY7B065A	64.5	48.4	192K x 12	64K x 12	16	13-bit	13-bit
NY7B076A	75.5	56.6	224K x 12	64K x 12	16	13-bit	13-bit
NY7B087A	86.4	64.8	256K x 12	64K x 12	16	13-bit	13-bit

- 448x4-bit RAM, divided into 2 pages.
- Up to 4MHz system clock for instruction execution.
- Slow mode to operate at low power consumption. (*+/-3% accuracy*)
- Halt mode to save power, less than 1uA@3V standby current.
- Built-in internal Ring oscillation is accurate with +/- 0.5% frequency deviation.
- Low voltage reset (LVR=1.9V) and watch-dog reset (WDT) are supported to protect the system.
- One interrupt entrance for multiple interrupt sources with an independent stack.
- Up to 16 flexible Bi-direction I/Os. Direction of each I/O is independently controlled by individual register bit.
- Each Bi-direction I/O pin can be optioned as different input and output function. For the input option, users can select one of three kinds of option: input with pull-high resistor, input without pull-high resistor, or input with register-controlled pull-high resistor (high-to-low wakeup only). For the output option, users can select one of three kinds of option: output with normal drive current and normal sink current, large sink current or constant sink current. (*Mask option*)
- Shared pins to provide IR carrier and external reset feature: PD2/IR & PD3/Reset. (*Mask option*)
- Selection of IR carrier frequency and data high/low IR output is supported.
- Maximum of 8 channels can be played simultaneously, each channel can be arbitrarily assigned as speech or MIDI channel.
- New high fidelity 6-bit ADPCM speech/ MIDI timbre synthesis algorithm and ADSR with 256-step envelope for MIDI synthesis.
- Patented noise filtering algorithm with 128KHz over sampling to enhance signal-to-noise ratio and provide excellent sound quality without ROM size increas
- 16-step digital volume control for synthetic speech/melody.
- Built-in hardware automatic Tone-Calibration of near-zero frequency deviation for precise tone frequency.
- High quality 13-bit DAC, or 13-bit push-pull amplifier audio output with 4-level mask-option analog volume of 100%, 83%, 66% and 50%. (*Push-Pull output power $P_{out}=1.3W@V_{DD}=5V$, $THD+N=10%$, $F=1kHz$, $R_L=4\Omega$.)*)

3. BLOCK DIAGRAM

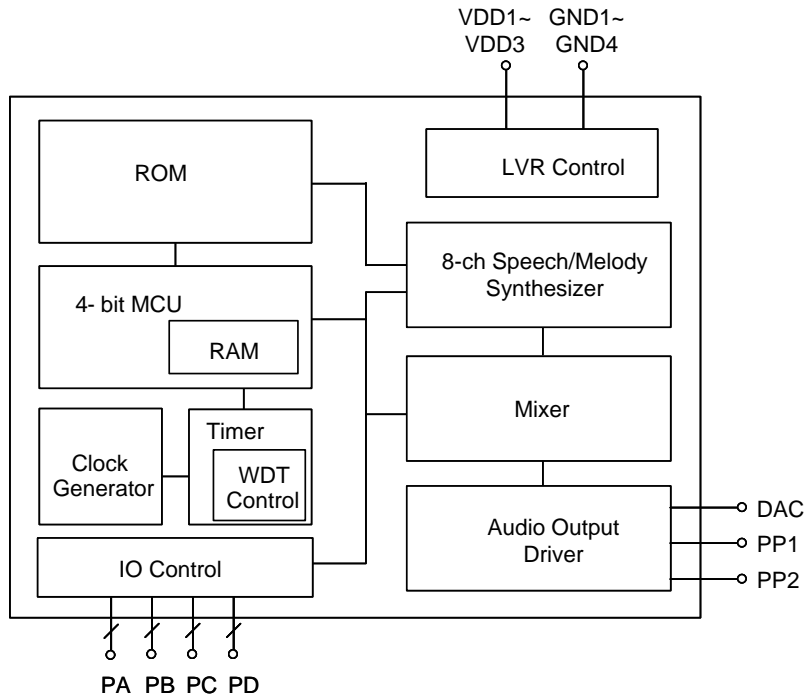

4. PAD DESCRIPTION

Pad Name	ATTR.	Description
VDD1~3	Power	Positive power.
GND1~4	Power	Negative power.
PA0~3	I/O	Bit 0~3 for Port A
PB0~3	I/O	Bit 0~3 for Port B
PC0~3	I/O	Bit 0~3 for Port C
PD0~1	I/O	Bit 0~1 for Port D.
PD2/IR	I/O, O	Bit2 of Port D, or IR carrier output.
PD3/Reset	I/O, I	Bit3 of Port D, or external reset input.
DAC	O	DAC output.
PP1	O	Push-Pull output 1.
PP2	O	Push-Pull output 2.

5. MEMORY ORGANIZATION

There are maximum 256K words ROM, 448 nibbles of RAM and 32 nibbles of dedicated System Function Register (SFR).

5.1 ROM

A large program/data/voice single ROM is provided, and its structure is shown below. The reserved region contains system information and can't be utilized by users. After reset process is completed, NY7B will start program execution from address 0x400.

Because program page size is 64K words defined by 16-bit length address of ROM, allowable range of unconditional branch instructions JMP and CALL are limited by program page size. However, combining with 2-bit BANK register (address \$10 of System Function Register), the total program size is 256K words. If users want to branch to program which is located beyond current program bank, user can change the BANK register first and then execute JMP or CALL instruction.

Address	ROM
0x00000	Interrupt Vector
0x0000F 0x00010	
0x003FF 0x00400	Reserved
0x0FFFF 0x10000	Program & Data Page 0
0x3FFFF	Program & Data Page 1 ~ 3

Instructions RJMP and RCALL associated with RPT[17:0] can be used as indirect branch and BANK register is ignored. Instruction LDPRI can handle 18-bit length address of ROM.

5.2 RAM

There are two pages of RAM, each page of RAM contains 224 nibbles. It's total 448 nibbles. The page of RAM defined by instruction (PAGE0, PAGE1), and its initial is PAGE0. System Function Registers will occupy address space from 0x00 to 0x1F. Moreover, this address space of PAGE0 and PAGE1 are mapped to the same System Function Registers. As consequence, the address space of PAGE0 and PAGE1 RAM which can be used by programmer is 0x20~0xFF.

The address space from 0x20 to 0x3F of PAGE0 and PAGE1 can be used with four special instructions MVRM, MVMR, BSET and BCLR. These instructions can access this range of memory space in single instruction cycle.

Address	RAM
0x00	System Function Register
0x1F 0x20	
0xFF	224 Nibbles General SRAM

(Page 0 & Page 1)

In addition to the immediate addressing mode, the indexed addressing mode is also supported. The page and address of the indexed RAM should be stored into RPT1 and RPT0 first, and users can read from or write in the XMD memory register to realize the indexed RAM access.

6. INTERNAL OSCILLATOR

The system clock is 4MHz, which is fast enough for many kinds of applications. The clock generator is a Ring oscillator, and users can only select the internal resistor oscillation (INT-R). The INT-R oscillator accuracy is up to $\pm 0.5\%$.

7. I/O PORTS

There are at most 16 I/O pins, designated as PAX through PDx, and x=0~3. All the I/O pins are bi-directional. An individual and independent register bit can determine the direction of each I/O pin.

Using as input pin of each I/O, there are 3 kinds of mask option. Users can select input with pull-high resistor, input without pull-high resistor, or input with register-controlled pull-high resistor (high-to-low wakeup only).

If users want to enable/disable pull-high resistor by register during program execution, only high-to-low level change on this pin can wakeup NY7B. On the other hand, if the pull-high resistor is fixed by option, either high-to-low or low-to-high level change on this pin can wakeup NY7B.

The pull-high resistor of all the I/O pins has two kinds of option: weak and strong. The weak one is about $1.2M\Omega@3V$ for normal application and the strong one is about $100K\Omega@3V$ usually for key matrix function. When users decide this option, the same strength of pull-high resistor will be applied to every I/O pin.

Using as output pin of each I/O, there are 3 kinds of mask option. Users can select output with normal drive current and normal sink current, normal drive current and large sink current, or normal drive current and constant sink current.

The I/O pin PD2/IR is also a multi-function pin. PD2 can be optioned as IR carrier pin and IR carrier frequency can be determined by a 5-bit option. There is another option to determine IR carrier is present according to data value is high or low.

The I/O pin PD3/Reset can be used as external reset pin by setting option. When PD3 is used as external reset, an active low signal on this pin will reset NY7B.

8. TIME BASE INTERRUPT

There are four kinds of time base interrupt period provided by NY7B: 0.064ms, 0.128ms, 0.256ms and 1.024ms. Users can select one of them by writing register INT[1:0].

If polling method is adopted to know time base status, reading INT[3:0] register can get the status of these four timer base. If interrupt method is adopted to implement a tick timer for application, writing 1 to register ONOFF[0] will enable time base interrupt.

9. AUDIO SYNTHESIZER

NY7B provide 8-CH Speech/MIDI synthesizer to play voice and patch-wave melody. All synthesis is provided by hardware and each channel can synthesize voice/MIDI independently.

For each synthetic channel, it has one 8-bit envelope register to multiply with voice data or patch-wave data. There is a hardware Mixer to add these 8 synthetic data to provide final result. However, before the first PLAY instruction is executed, users have to wait about 40us after Mixer is enabled.

The final result can be controller by a 4-bit register to adjust its volume and then it is sent to Audio Output to produce analog audio signal to drive external speaker.

NY7B provide two kinds of Audio Output: one is 13-bit DAC and the other is 13-bit Push-Pull amplifier.

9.1 Speech Synthesis

NY7B supports 10-bit PCM and encoded 6-bit ADPCM speech data. The PCM voice has higher quality, but it occupies double ROM space than the ADPCM one. By cooperating with embedded noise filter of 128 KHz over-sampling, it could decode high fidelity voice data even if you adopt ADPCM voice. It means you could store longer voice duration or provide more kinds of patch at lower sampling rate but enrich user's applications without degradation of sound quality.

9.2 MIDI Synthesis

NY7B provide three kinds of method to construct a patch-wave of timbre (instrument). The first method is to record a complete waveform, then play it by playing whole wave only. It is usually called "Head Only". This is the best way to represent a best quality melody at the expense of ROM space.

The second method is called "Head wave + Tail Loop" with envelope information representing ADSR (Attack-Decay-Sustain-Release). It is the recommended way to construct a patch-wave in NY7, which can provide high quality melody without sacrificing too much ROM space.

The third method is to use periodic portion of an instrument to represent a patch. It is called "Tail Loop". This method will occupy less ROM space with acceptable audio quality.

9.3 Audio Output

NY7B provides two kinds of audio output: 13-bit DAC and 13-bit Push-Pull amplifier. By programming register CHARC[3:2] with appropriate value, users can select one of them to drive external speaker.

When Push-Pull amplifier is selected, users have to wait about 100us until Push-Pull amplifier is stable. [Moreover, there are 4 mask options to adjust Push-Pull gain for volume adjustment. These 4 mask options correspond to 100%, 83%, 66% or 50% of maximum analog volume output.](#)

Due to 1.3W output power of Push-Pull amplifier, the bonding wire of 1.0mil diameter is suggested when a 4Ω speaker is applied. Otherwise the bonding wires may be burned-out.

9.4 Envelope Control

During speech synthesis or melody synthesis, there is one 8-bit envelope register (ENVH and ENVL), which can store the envelope information. Therefore NY7B can provide 256 levels envelope control and users can use it as alternative of volume control.

9.5 Volume Control

There are 16 steps volume control, which can be applied to synthetic digital data for the Mixer output no matter DAC or Push-Pull amplifier is selected.

When users write value to register VOL[3:0], this value will multiply with Mixer output to adjust the volume of final synthetic result.

10. WATCH-DOG TIMER (WDT)

To recover from program malfunction, the NY7B IC supports an embedded watch-dog timer reset. Users have to clear the WDT periodically to prevent from timing up with a reset generation.

Typically, the minimum time-up period of the WDT is about 28ms and users can clear WDT through instruction CWDT.

11. OPERATING MODE

NY7B provide 3 kinds of operating mode: Normal, Slow and Halt mode. After power is turned on, NY7B will start its reset process. The power on stable time is about 131ms. After reset process is completed, NY7B will enter Normal mode.

In Normal mode, the system clock is 4MHz. User can implement sorts of application in this mode. On the other hand, users can select Slow mode or Halt mode to save power consumption.

11.1 Slow Mode

NY7B will enter Slow mode if SLOW instruction is executed. The system clock of Slow mode is about 16 times slower than that of Normal mode, and the frequency accuracy is +/- 3%. The instruction will not be executed at Slow mode.

NY7B can wake up from Slow mode by interrupt request or level change on I/O pin. The stable time after wake up from Slow mode is about 50us.

11.2 Halt Mode

NY7B will enter Halt mode if the HALT instruction is executed. At Halt mode, system clock is completely disabled and all IC functions stop to minimize the power consumption.

The only way to wake up NY7B from Halt mode is level change on I/O pin. The stable time after wake up from Halt mode is about 50us.

12. ELECTRICAL CHARACTERISTICS

12.1 Absolute Maximum Rating

Symbol	Parameter	Rated Value	Unit
$V_{DD} - V_{SS}$	Supply voltage	-0.5 ~ +6.0	V
V_{IN}	Input voltage	$V_{SS}-0.3V \sim V_{DD}+0.3$	V
T_{OP}	Operating Temperature	0 ~ +70	°C
T_{ST}	Storage Temperature	-25 ~ +85	°C

12.2 DC Characteristics

Symbol	Parameter	VDD	Min.	Typ.	Max.	Unit	Condition
V_{DD}	Operating voltage	-	2.0	3	5.5	V	4MHz
I_{SB}	Halt mode	3.0		0.1	0.5	uA	Sleep, no load.
		4.5		0.1	0.5		
I_{SL}	Slow mode	3.0		190		uA	Slow, no load.
		4.5		380			
I_{OP}	Normal mode (DAC output)	3.0		2.2		mA	4MHz, no load.
		4.5		4.8			
	Normal mode (PP output)	3.0		3.8		mA	
		4.5		7.2			
I_{IL}	Weak (1.2M ohms)	3.0		2.5		uA	$V_{IL}=0V$
		4.5		7.4			
	Strong (100k ohms)	3.0		30		uA	
		4.5		75			
I_{OH}	Output high current	3.0		-7		mA	$V_{OH}=2.0V$
		4.5		-11			$V_{OH}=3.5V$
I_{OL}	Output low current (Normal current)	3.0		11		mA	$V_{OL}=1.0V$
		4.5		17			
	Output low current (Large current)	3.0		22		mA	
		4.5		33			
	Output low current (Constant current)	3.0		20		mA	
		4.5		21			
I_{DAC}	DAC output current	3.0		1.4		mA	Half scale
		4.5		1.6			
I_{PP}	Push-Pull output current	3.0		180		mA	Load=8 Ω
		4.5		270			
$\Delta F/F$	Frequency deviation by voltage drop	3.0		0.5		%	$\frac{F_{osc}(3.0v)-F_{osc}(2.4v)}{F_{osc}(3v)}$
		4.5		-0.5			$\frac{F_{osc}(4.5v)-F_{osc}(3.0v)}{F_{osc}(4.5v)}$
	Frequency lot deviation	--	-0.5		0.5	%	$\frac{F_{max}(V_{DD})-F_{min}(V_{DD})}{F_{max}(V_{DD})}$
F_{osc}	Oscillation Frequency	--	3.6	4	4.1	MHz	$V_{DD}=2.0\sim 5.5V$

12.3 Voltage vs. Frequency

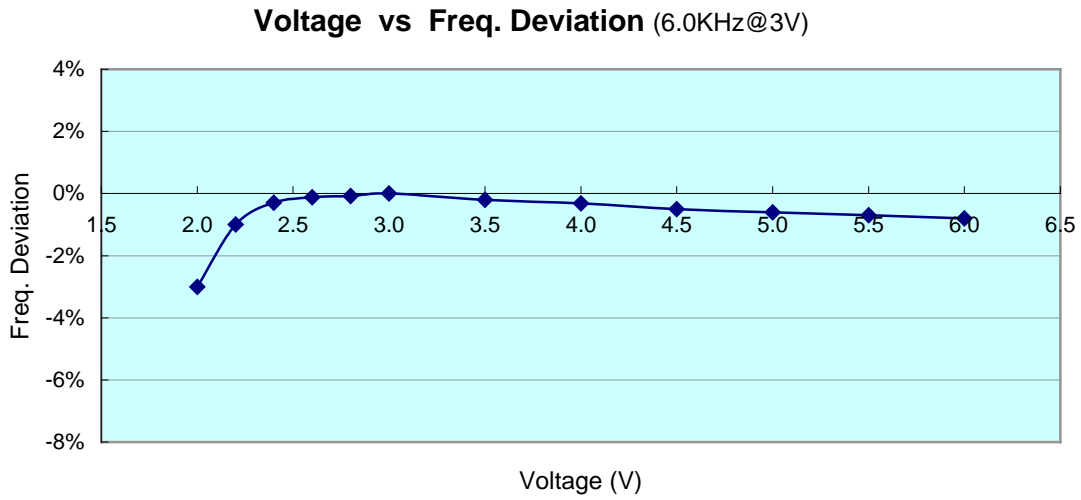

13. APPLICATION

(1) Push-Pull Output

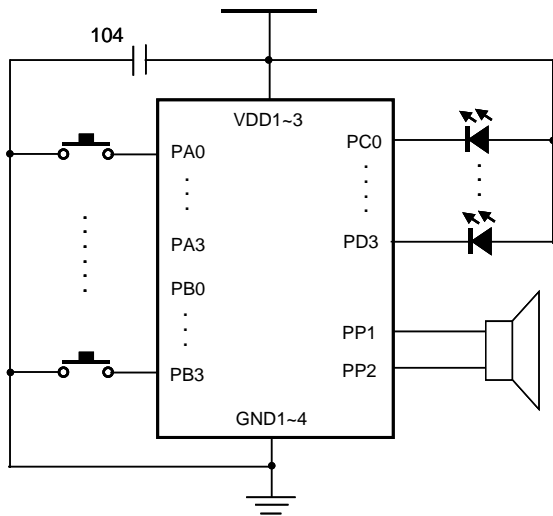

(2) DAC Output

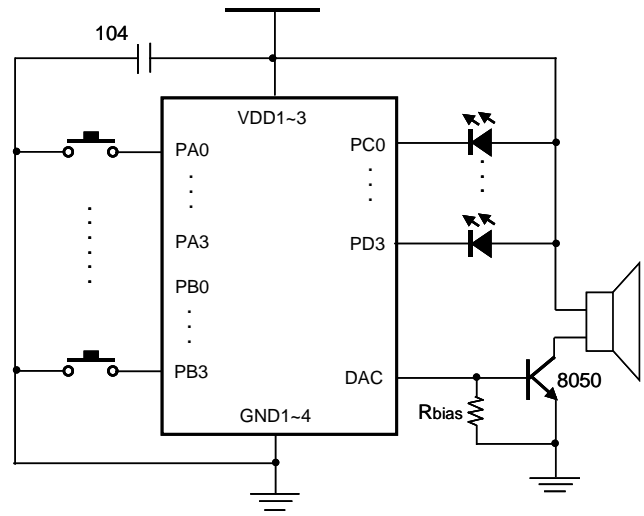

14. DIE PAD DIAGRAM

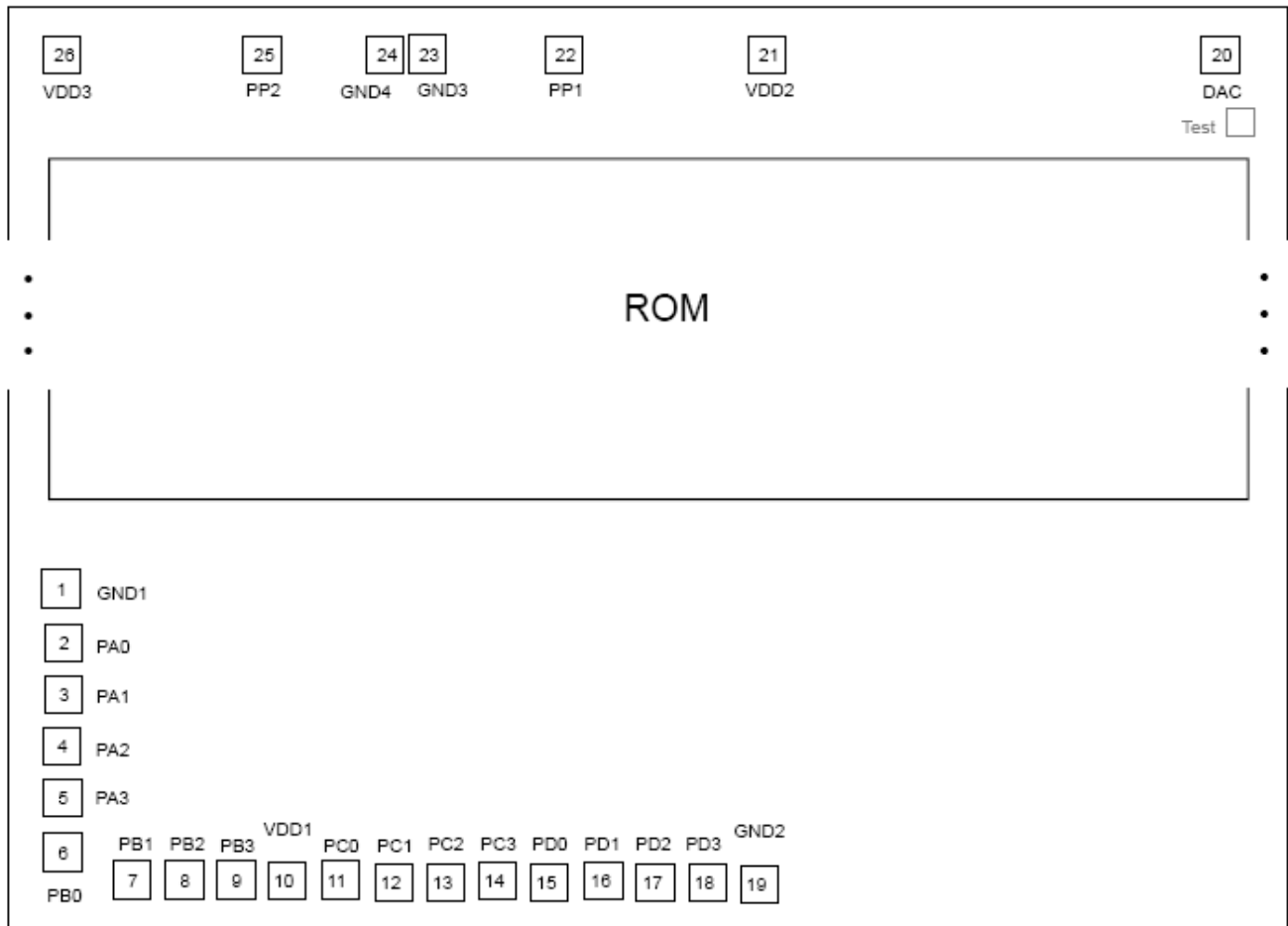

* The IC substrate must be connected to GND or Floating.