

**ARM[®] Cortex[®]-M
32-bit Microcontroller**

**NuMicro[®] Family
Nano103 Series
Datasheet**

The information described in this document is the exclusive intellectual property of Nuvoton Technology Corporation and shall not be reproduced without permission from Nuvoton.

Nuvoton is providing this document only for reference purposes of NuMicro microcontroller based system design. Nuvoton assumes no responsibility for errors or omissions.

All data and specifications are subject to change without notice.

For additional information or questions, please contact: Nuvoton Technology Corporation.

www.nuvoton.com

Table of Contents

1 GENERAL DESCRIPTION 7

 1.1 Connectivity Support Table 7

2 FEATURES 8

3 ABBREVIATIONS 14

 3.1 ABBREVIATIONS 14

4 PARTS INFORMATION LIST AND PIN CONFIGURATION 16

 4.1 NuMicro® Nano103 Series Selection Code 16

 4.2 NuMicro® Nano103 Products Selection Guide 17

 4.2.1 NuMicro® Nano103 Base Line Selection Guide 17

 4.3 Pin Configuration 18

 4.3.1 NuMicro® Nano103 Pin Diagrams 18

 4.4 Pin Description 21

 4.4.1 NuMicro® Nano103 Pin Description 21

5 BLOCK DIAGRAM 29

 5.1 Nano103 Block Diagram 29

6 FUNCTIONAL DESCRIPTION 30

 6.1 ARM® Cortex®-M0 Core 30

 6.2 System Manager 32

 6.2.1 Overview 32

 6.2.2 Features 32

 6.3 Clock Controller 33

 6.3.1 Overview 33

 6.3.2 Features 33

 6.4 Flash Memory Controller (FMC) 34

 6.4.1 Overview 34

 6.4.2 Features 34

 6.5 General Purpose I/O Controller 35

 6.5.1 Overview 35

 6.5.2 Features 35

 6.6 PDMA Controller (PDMA) 36

 6.6.1 Overview 36

 6.6.2 Features 36

 6.7 Timer Controller 38

- 6.7.1 Overview 38
- 6.7.2 Features 38
- 6.8 PWM Generator and Capture Timer (PWM) 39
 - 6.8.1 Overview 39
 - 6.8.2 Features 39
- 6.9 Watchdog Timer Controller 41
 - 6.9.1 Overview 41
 - 6.9.2 Features 41
- 6.10 Window Watchdog Timer Controller 42
 - 6.10.1 Overview 42
 - 6.10.2 Features 42
- 6.11 Real Time Clock (RTC) 43
 - 6.11.1 Overview 43
 - 6.11.2 Features 43
- 6.12 UART Controller 44
 - 6.12.1 Overview 44
 - 6.12.2 Features 44
- 6.13 Smart Card Host Interface (SC) 45
 - 6.13.1 Overview 45
 - 6.13.2 Features 45
- 6.14 I²C Serial Interface Controller (I²C) 46
 - 6.14.1 Overview 46
 - 6.14.2 Features 46
- 6.15 SPI 47
 - 6.15.1 Overview 47
 - 6.15.2 Features 47
- 6.16 Analog to Digital Converter (ADC) 48
 - 6.16.1 Overview 48
 - 6.16.2 Features 48
- 6.17 Analog Comparator Controller (ACMP0) 49
 - 6.17.1 Overview 49
 - 6.17.2 Features 49
- 7 APPLICATION CIRCUIT 50
- 8 Power COMSUMPTION 51
- 9 ELECTRICAL CHARACTERISTICS 53

9.1 Absolute Maximum Ratings53

9.2 Nano103 DC Electrical Characteristics.....54

9.3 AC Electrical Characteristics71

 9.3.1 External Input Clock71

 9.3.2 External 4~24 MHz XTAL Oscillator72

 9.3.3 External 32.768 kHz Crystal73

 9.3.4 Internal 36 MHz Oscillator74

 9.3.5 Internal 12 MHz Oscillator74

 9.3.6 Internal 4 MHz Oscillator75

 9.3.7 Internal 10 kHz Oscillator.....75

9.4 Analog Characteristics76

 9.4.1 12-bit ADC76

 9.4.2 Brown-out Detector77

 9.4.3 Power-on Reset78

 9.4.4 Low-Voltage Reset78

 9.4.5 Temperature Sensor78

 9.4.6 Internal Voltage Reference.....79

 9.4.7 Comparator79

10 PACKAGE DIMENSIONS80

 10.1 64S LQFP (7 x 7 mm². Thickness 1.4 mm).....80

 10.2 48L LQFP (7 x 7 mm². Thickness 1.4 mm)83

 10.3 33L QFN (5 x 5 mm². Thickness 0.8 mm)84

11 REVISION HISTORY86

LIST OF FIGURES

Figure 4.1-1 NuMicro® Nano103 Series Selection Code 16

Figure 4.3-1 NuMicro® Nano103 LQFP 64-pin Diagram 18

Figure 4.3-2 NuMicro® Nano103 LQFP 48-pin Diagram 19

Figure 4.3-3 NuMicro® Nano103 QFN33-pin Diagram 20

Figure 5.1-1 NuMicro® Nano103 Block Diagram 29

Figure 6.1-1 Functional Block Diagram 30

Figure 9-1 Typical High Speed Crystal Application Circuit 72

Figure 9-2 Typical Low Speed Crystal Application Circuit 73

LIST OF TABLES

Table 1.1-1 Connectivity Support Table..... 7
Table 3.1-1 List of Abbreviations..... 15

1 GENERAL DESCRIPTION

The Nano103 series ultra-low-power 32-bit microcontroller embeded with ARM® Cortex®-M0 core operates at low voltage ranged from 2.2V to 3.6V and runs up to 36 MHz frequency with 64 KB embedded Flash (APROM) and 16 KB embedded SRAM and 4 KB Flash loader memory (LDRAM) for In-System Programming (ISP).

The Nano103 series integrates RTC with independent V_{BAT} pin, 12-bit SAR ADC, comparator and provides high performance connectivity peripheral interfaces such as UART, SPI, I²C, GPIOs, and ISO-7816-3 for Smart card.

The Nano103 series supports main power off with only V_{BAT} and RTC on less than 1.0 µA and Deep Power-down mode with RAM retention is less than 1.6 µA and fast wake-up via many peripheral interfaces.

The Nano103 series provides low voltage, low operating power consumption, low standby current, high integration peripherals, high-efficiency operation, fast wake-up function and the lowest cost 32-bit microcontrollers. The Nano103 series is suitable for a wide range of battery device applications such as:

- Hand-Held Medical Device
- Wearable Device & Smart Watch
- Wireless Gaming Control, Thermostats, Sensors Node Device (WSND)
- Wireless Auto Meter Reading (AMR)
- RFID Reader
- Portable Wireless Data Collector
- Mobile Payment Smart Card Reader
- Security Alarm System
- Smart Home Appliance
- Smart Water, Gas, Heat Meters

1.1 Connectivity Support Table

Product Line	UART	SPI	I ² C	ADC	ACMP	RTC/V _{bat}	SC	Timer
Nano103	●	●	●	●	●	●	●	●

Table 1.1-1 Connectivity Support Table

2 FEATURES

- Low Supply Voltage Range: 2.2V to 3.6V
- Operating Temperature: -40°C~105°C
- Four power modes
 - ◆ Normal mode
 - ◆ Idle mode
 - ◆ Power-down mode with RTC on and RAM retention
 - ◆ RTC domain only
- Wake-up sources
 - ◆ RTC, WDT, I²C, Timer, UART, SPI, BOD, GPIO
- Fast wake-up from power-down mode: less than 3.5 μs when using HIRC0
- Brown-out
 - ◆ Built-in 1.7~3.1V BOD for wide operating voltage range operation
 - ◆ Built-in low power 2.0/2.5V BOD
- Core
 - ◆ ARM[®] Cortex[®]-M0 core running up to 36 MHz
 - ◆ One 24-bit system timer
 - ◆ Supports Low Power Sleep mode
 - ◆ Single-cycle 32-bit hardware multiplier
 - ◆ NVIC for the 32 interrupt inputs, each with 4-levels of priority
 - ◆ Serial Wire Debug supports with 2 watchpoints/4 breakpoints
- Flash EPROM Memory
 - ◆ 64 KB application program memory (APROM)
 - ◆ 4 KB in system programming (ISP) loader program memory (LDROM)
 - ◆ Programmable data flash start address and memory size with 512 bytes page erase unit
 - ◆ In System Program (ISP)/In Application Program (IAP) to update on-chip Flash EPROM
- SRAM Memory
 - ◆ 16 KB embedded SRAM
 - ◆ Supports DMA mode
- DMA: Supports Five channels including four PDMA channels and one CRC channel
 - ◆ PDMA
 - Three modes: peripheral-to-memory, memory-to-peripheral, and memory-to-memory transfer
 - Source address and destination address must be word alignment in all modes.
 - Memory-to-memory mode: transfer length must be word alignment.
 - Peripheral-to-memory and memory-to-peripheral mode: transfer length

- could be word/half-word/byte alignment.
 - Peripheral-to-memory and memory-to-peripheral mode: transfer data width could be word/half-word/byte alignment
 - Supports source and destination address direction: increment, fixed, and wrap around
- ◆ CRC
 - Supports four common polynomials CRC-CCITT, CRC-8, CRC-16, and CRC-32
 - ◆ CRC-CCITT: $X^{16} + X^{12} + X^5 + 1$
 - ◆ CRC-8: $X^8 + X^2 + X + 1$
 - ◆ CRC-16: $X^{16} + X^{15} + X^2 + 1$
 - ◆ CRC-32: $X^{32} + X^{26} + X^{23} + X^{22} + X^{16} + X^{12} + X^{11} + X^{10} + X^8 + X^7 + X^5 + X^4 + X^2 + X + 1$
- Clock Control
 - ◆ Built-in 12/16MHz OSC (HIRC0) has 2 % deviation within all temperature range. Deviation could be reduced to 1% if turning on auto-trim function.
 - ◆ Built-in 36MHz OSC(HIRC1)
 - ◆ Built-in 4MHz OSC(MIRC)
 - ◆ Supports one PLL, up to 36 MHz, for high performance system operation
 - ◆ External 4~24 MHz(HXT) crystal input for precise timing operation
 - ◆ Low power 10 kHz OSC(LIRC) for watchdog and low power system operation
 - ◆ External 32.768 kHz(LXT) crystal input for RTC and low power system operation
- GPIO
 - ◆ Three I/O modes:
 - Push-Pull output
 - Open-Drain output
 - Input only with high impedance
 - ◆ All inputs with Schmitt trigger
 - ◆ I/O pin configured as interrupt source with edge/level setting
 - ◆ Supports input 5V tolerance, except
 - PA.0 ~ PA.7 (sharing pin with ADC),
 - PA.12~ PA.13 (sharing pin with comparator),
 - PF.0~ PF.1 and PF.6 ~ PF.7(sharing pin with HXT and LXT)
 - PA.8, PB.4 and PB.5
- Timer
 - ◆ Supports 4 sets of 32-bit timers, each timer with 24-bit up-counting timer and one 8-bit pre-scale counter
 - ◆ Each timer could have independent clock source selection
 - ◆ Supports one-shot,periodic, output toggle and continuous operation modes

- ◆ Internal trigger event to ADC and PDMA
- ◆ Supports PDMA mode
- ◆ Wake system up from Power-down mode
- Watchdog Timer
 - ◆ Clock Source from LIRC (Internal 10 kHz Low Speed Oscillator Clock)
 - ◆ Selectable time-out period from 1.6 ms ~ 26 sec (depending on clock source)
 - ◆ Interrupt or reset selectable when watchdog time-out
 - ◆ Wakes system up from Power-down mode
- Window Watchdog Timer(WWDT)
 - ◆ 6-bit down counter and 6-bit compare value to make the window period flexible
 - ◆ Selectable WWDT clock pre-scale counter to make WWDT time-out interval variable.
- RTC
 - ◆ Supports software compensation by setting frequency compensate register (FREQADJ)
 - ◆ Supports RTC counter (second, minute, hour) and calendar counter (day, month, year)
 - ◆ Supports Alarm registers (second, minute, hour, day, month, year)
 - ◆ Selectable 12-hour or 24-hour mode
 - ◆ Automatic leap year recognition
 - ◆ Supports periodic time tick interrupt with 8 periodic options 1/128, 1/64, 1/32, 1/16, 1/8, 1/4, 1/2 and 1 second
 - ◆ Wake system up from Power-down mode
 - ◆ Supports 20 bytes spare registers and a tamper pin to clear the content of these spare registers
 - ◆ Supports 1 Hz clock output
 - ◆ Support independent V_{BAT} power domain to provide for PF.6~PF.7 (sharing pin with LXT) and tamper pins (LQFP64: PB.13/LQFP48: PA.9/QFN32: PB.8)
- PWM/Capture
 - ◆ Supports one PWM module to provides 6 output channels
 - ◆ Supports independent mode for PWM output/Capture input channe
 - ◆ Supports complementary mode for 3 complementary paired PWM output channel
 - ◆ Supports 16-bit resolution PWM counter, each module provides 3 PWM counters
 - ◆ Supports PWM triggerADC function
 - ◆ Supports up to 12 capture input channels with 16-bit resolution
- UART
 - ◆ Supports up to two sets of UART
 - ◆ Up to 1 Mbit/s baud rate

- ◆ Support 9600 baud rate at 32.768 kHz
- ◆ Up to two 16-byte FIFO UART controllers
- ◆ UART ports with flow control (TX, RX, nCTS and nRTS)
- ◆ Supports IrDA (SIR) function
- ◆ Supports LIN function
- ◆ Supports RS-485 9 bit mode and direction control.
- ◆ Programmable baud rate generator
- ◆ Supports PDMA mode
- ◆ Supports wake-up function (nCTS, incoming RX data, RS-485 AAD mode address matched or received FIFO is equal to the RFITL)
- SPI
 - ◆ Up to two sets of SPI controllers
 - ◆ Supports Master (max. 32 MHz) or Slave (max. 16 MHz) mode operation
 - ◆ Supports 1 bit and 2 bit transfer mode
 - ◆ Support Dual IO transfer mode
 - ◆ Configurable bit length of a transaction from 8 to 32-bit
 - ◆ Supports MSB first or LSB first transfer sequence
 - ◆ Two slave select lines supported in Master mode
 - ◆ Configurable byte or word suspend mode
 - ◆ Supports byte re-ordering function
 - ◆ Supports variable serial clock in Master mode
 - ◆ Provide separate 8-level depth transmit and receive FIFO buffer
 - ◆ Supports wake-up function(SPI clock toggle in Power-down mode)
 - ◆ Supports PDMA transfer
 - ◆ Supports 3-wires, no slave select signal, bi-direction interface
- I²C
 - ◆ Up to two sets of I²C device
 - ◆ Master/Slave up to 1 Mbit/s
 - ◆ Bi-directional data transfer between masters and slaves
 - ◆ Multi-master bus (no central master)
 - ◆ Arbitration between simultaneously transmitting masters without corruption of serial data on the bus
 - ◆ Serial clock synchronization allows devices with different bit rates to communicate via one serial bus
 - ◆ Serial clock synchronization used as a handshake mechanism to suspend and resume serial transfer
 - ◆ Built-in 14-bit time-out counter requesting the I²C interrupt if the I²C bus hangs up and timer-out counter overflows
 - ◆ Programmable clocks allowing for versatile rate control

- ◆ Supports 7-bit addressing mode
- ◆ Supports multiple address recognition (four slave addresses with mask option)
- ◆ Wake system up(address match) from Power-down mode
- ADC
 - ◆ 12-bit SAR ADC
 - ◆ Up to 12 channels: 8 external channel(PA.0 ~ PA.6 and PC.7) and 4 internal channels.
 - ◆ Four internal channels: internal reference voltage (Int_V_{REF}), Temperature sensor, AV_{DD}, and AV_{SS}.
 - ◆ Supports three reference voltage sources: V_{REF} pin, internal reference voltage (Int_V_{REF}: 2.5V/1.8V/1.5V), and AV_{DD}.
 - ◆ Supports Single Scan, Single Cycle Scan, and Continuous Scan mode
 - ◆ Each channel with individual result register
 - ◆ Threshold voltage detection (comparator function)
 - ◆ Conversion started by software programming or external input
 - ◆ Supports PDMA mode
 - ◆ Supports up to four timer time-out events (TMR0, TMR1, TMR2 and TMR3) to enable ADC
- SmartCard (SC)
 - ◆ Compliant to ISO-7816-3 T=0, T=1
 - ◆ Supports up to two ISO-7816-3 ports
 - ◆ Separates receive/transmit 4 bytes entry FIFO for data payloads
 - ◆ Programmable transmission clock frequency
 - ◆ Programmable receiver buffer trigger level
 - ◆ Programmable guard time selection (11 ETU ~ 267 ETU)
 - ◆ A 24-bit and two 8-bit time-out counters for Answer to Request (ATR) and waiting times processing
 - ◆ Supports auto inverse convention function
 - ◆ Supports transmitter and receiver error retry and error limit function
 - ◆ Supports hardware activation sequence process
 - ◆ Supports hardware warm reset sequence process
 - ◆ Supports hardware deactivation sequence process
 - ◆ Supports hardware auto deactivation sequence when detect the card is removal
 - ◆ Supports UART mode (full-duplex)
- ACMP
 - ◆ Supports one comparator
 - ◆ Analog input voltage range: 0~AV_{DD}
 - ◆ Supports Hysteresis function
- 96-bit unique ID

- 128-bit unique customer ID
- Packages:
 - ◆ All Green package (RoHS)
 - ◆ LQFP 64-pin(7x7)
 - ◆ LQFP 48-pin(7x7)
 - ◆ QFN 33-pin(5x5)

3 ABBREVIATIONS

3.1 ABBREVIATIONS

Acronym	Description
ACMP	Analog Comparator Controller
ADC	Analog-to-Digital Converter
AES	Advanced Encryption Standard
APB	Advanced Peripheral Bus
AHB	Advanced High-Performance Bus
BOD	Brown-out Detection
CAN	Controller Area Network
DAP	Debug Access Port
DES	Data Encryption Standard
EBI	External Bus Interface
EPWM	Enhanced Pulse Width Modulation
FIFO	First In, First Out
FMC	Flash Memory Controller
FPU	Floating-point Unit
GPIO	General-Purpose Input/Output
HCLK	The Clock of Advanced High-Performance Bus
HIRC	12/16 MHz Internal High Speed RC Oscillator
HXT	4~24 MHz External High Speed Crystal Oscillator
IAP	In Application Programming
ICP	In Circuit Programming
ISP	In System Programming
LDO	Low Dropout Regulator
LIN	Local Interconnect Network
LIRC	10 kHz internal low speed RC oscillator (LIRC)
MPU	Memory Protection Unit
NTC	Negative Temperature Coefficient
NVIC	Nested Vectored Interrupt Controller
PCLK	The Clock of Advanced Peripheral Bus
PDMA	Peripheral Direct Memory Access
PLL	Phase-Locked Loop
PTC	Positive Temperature Coefficient
PT1000	Thermal Resistance

PWM	Pulse Width Modulation
QEI	Quadrature Encoder Interface
SDIO	Secure Digital Input/Output
SPI	Serial Peripheral Interface
SPS	Samples per Second
TDES	Triple Data Encryption Standard
TMR	Timer Controller
UART	Universal Asynchronous Receiver/Transmitter
UCID	Unique Customer ID
USB	Universal Serial Bus
WDT	Watchdog Timer
WWDT	Window Watchdog Timer

Table 3.1-1 List of Abbreviations

4 PARTS INFORMATION LIST AND PIN CONFIGURATION

4.1 NuMicro® Nano103 Series Selection Code

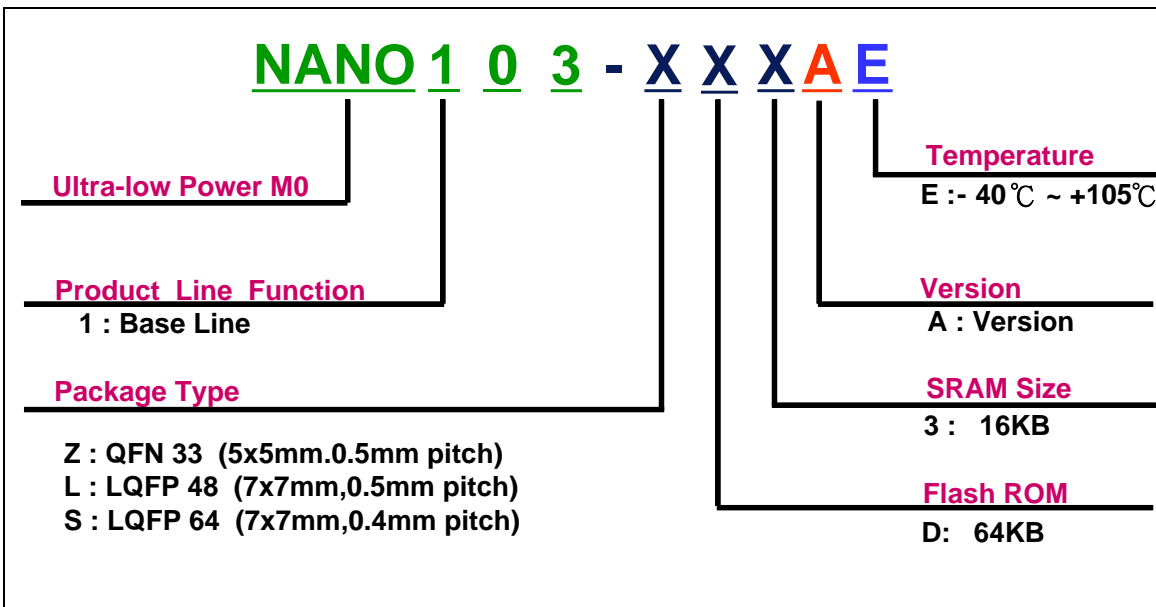

Figure 4.1-1 NuMicro® Nano103 Series Selection Code

4.2 NuMicro® Nano103 Products Selection Guide

4.2.1 NuMicro® Nano103 Base Line Selection Guide

Part No.	Flash (KB)	SRAM (KB)	Data Flash Shared AP ROM (KB)	LDROM (ISP Loader) (KB)	I/O	Timer	Connectivity			I ² S	PWM	12-bit ADC	ACMP	RTC	IRC 10 kHz 4 MHz 12/16 MHz 36 MHz	PDMA	ISO-7816-3*	ISP/ICP	Package
							UART*	SPI	I ² C										
NANO103ZD3AE	64	16	Configurable	4	26	4x32-bit	2+2	4	2	-	2	6	1	V	V	4	2	V	QFN33
NANO103LD3AE	64	16	Configurable	4	39	4x32-bit	2+2	4	2	-	6	8	1	V	V	4	2	V	LQFP48
NANO103SD3AE	64	16	Configurable	4	53	4x32-bit	2+2	4	2	-	6	8	1	V	V	4	2	V	LQFP64

*Marked in the table (2+2) means 2 UART + 2 ISO-7816 UART

*ISO-7816 UART supports UART full duplex mode

4.3 Pin Configuration

4.3.1 NuMicro® Nano103 Pin Diagrams

4.3.1.1 NuMicro® Nano103 LQFP 64-pin

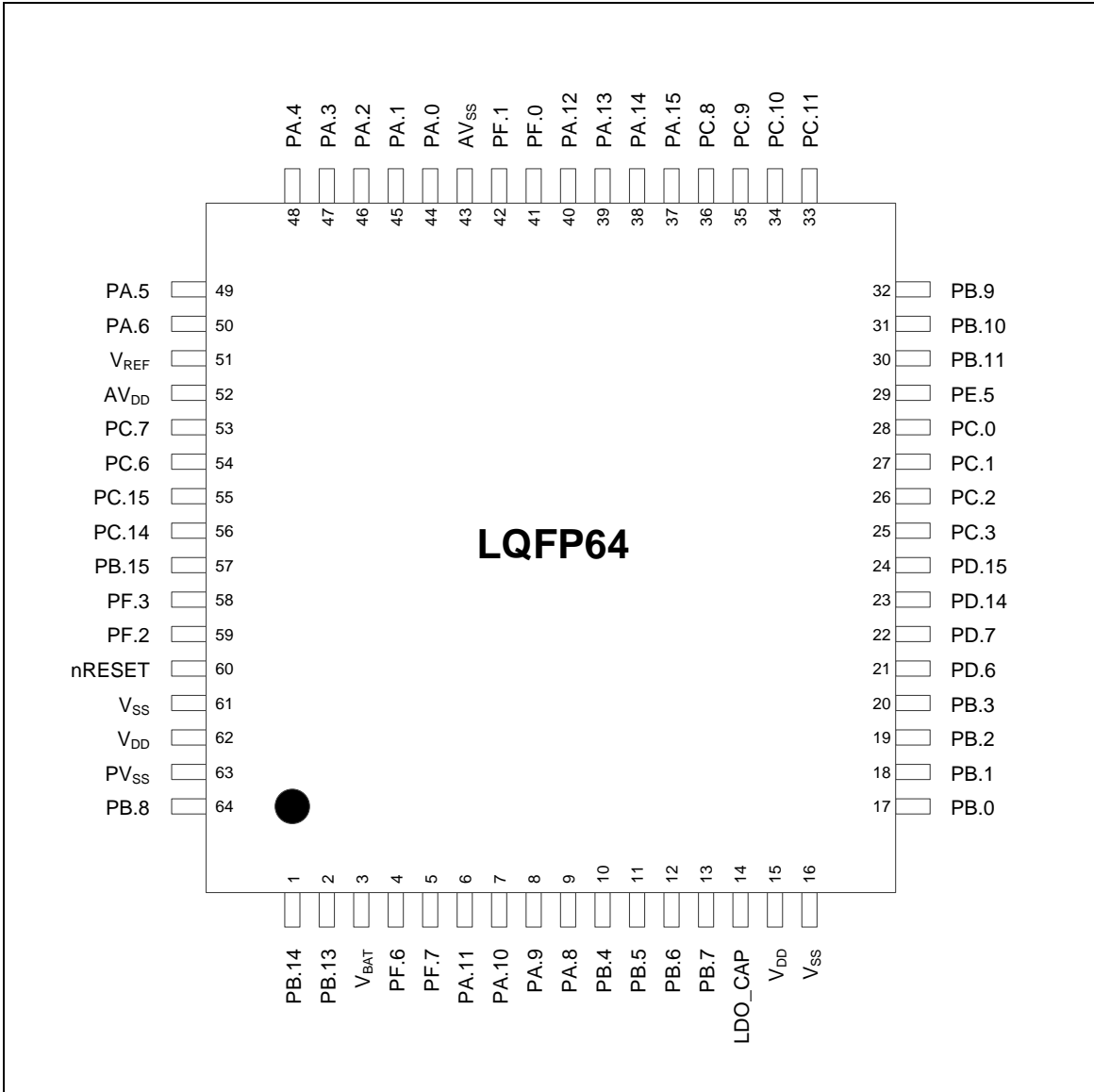

Figure 4.3-1 NuMicro® Nano103 LQFP 64-pin Diagram

4.3.1.2 NuMicro® Nano103 LQFP 48-pin

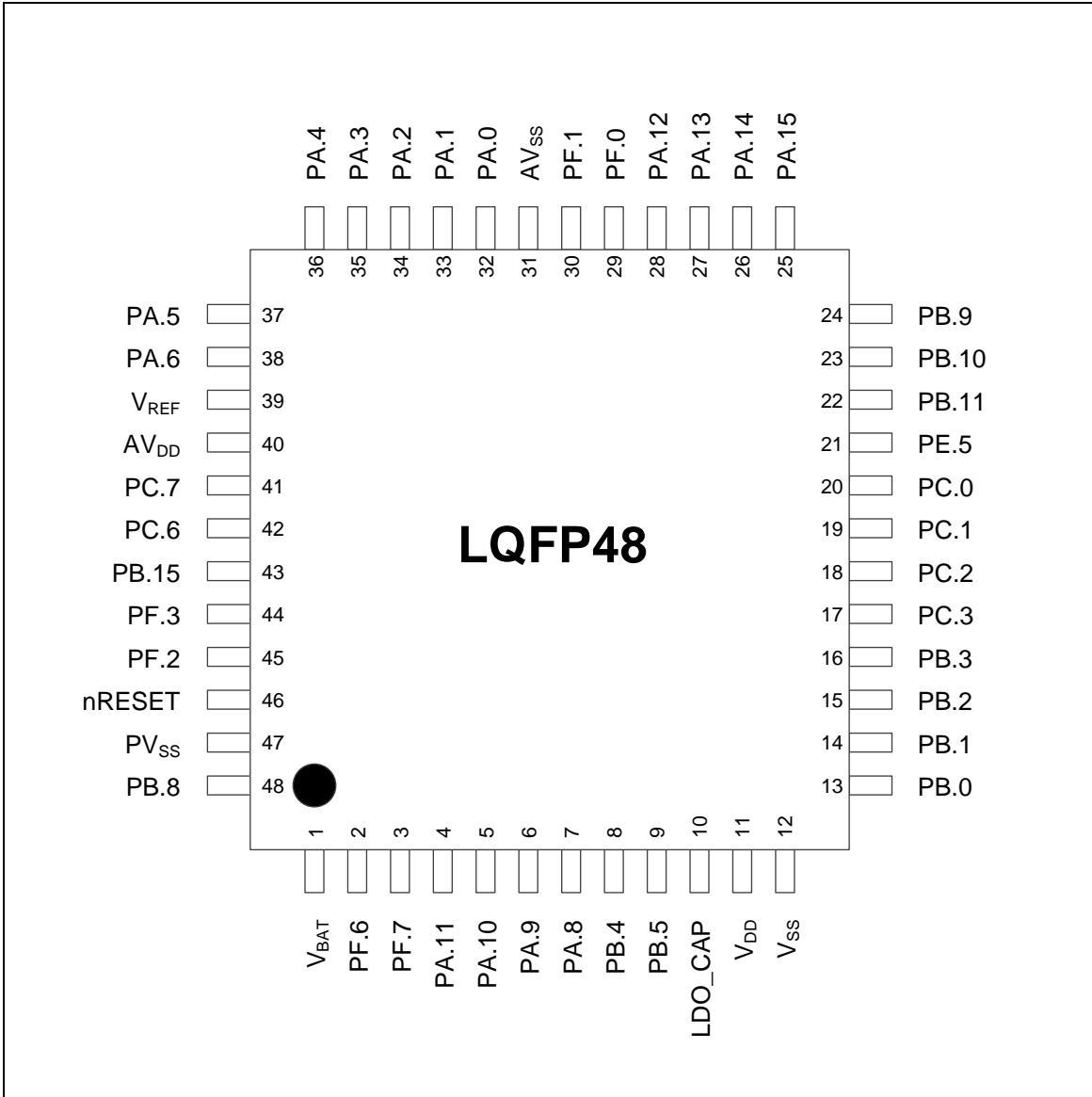

Figure 4.3-2 NuMicro® Nano103 LQFP 48-pin Diagram

4.3.1.3 NuMicro® Nano103 QFN33-pin

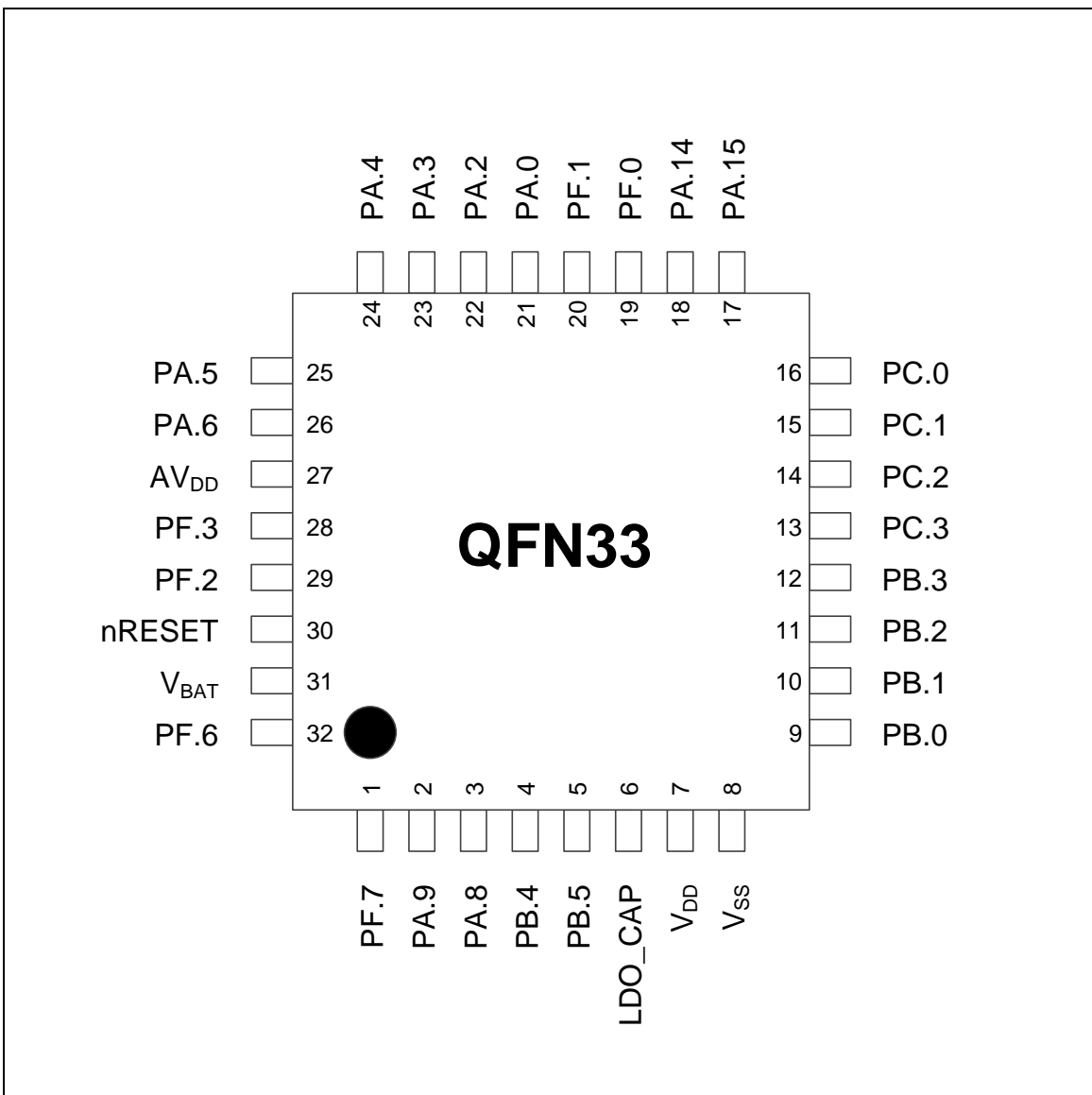

Figure 4.3-3 NuMicro® Nano103 QFN33-pin Diagram

4.4 Pin Description

4.4.1 NuMicro® Nano103 Pin Description

Pin No.			Pin Name	Pin Type	MFP*	Description
64-pin	48-pin	32-pin				
1	-	-	PB.14	I/O	MFP0	General purpose digital I/O pin.
			INT0	I	MFP1	External interrupt0 input pin.
			SPI2_MOSI1	I/O	MFP3	SPI2 2 nd MOSI (Master Out, Slave In) pin.
			SPI2_SS1	I/O	MFP4	SPI2 2 nd slave select pin.
2	-	-	PB.13	I/O	MFP0	General purpose digital I/O pin.
			SPI2_MISO1	I/O	MFP3	SPI2 2 nd MISO (Master In, Slave Out) pin.
			SNOOPER	I	MFP7	Snooper pin.
3	1	31	V _{BAT}	P	MFP0	Power supply for tamper pin (LQFP64: PB.13/LQFP48: PA.9/QFN32: PB.8) and RTC.
4	2	32	PF.6	I/O	MFP0	General purpose digital I/O pin.
			I2C1_SDA	I/O	MFP1	I2C1 data input/output pin.
			X32_OUT	O	MFP7	External 32.768 kHz crystal output pin(default).
5	3	1	PF.7	I/O	MFP0	General purpose digital I/O pin.
			I2C1_SCL	I/O	MFP1	I2C1 clock pin.
			SC0_CD	I	MFP3	SmartCard0 card detect pin.
			X32_IN	I	MFP7	External 32.768 kHz crystal input pin(default).
-	-	2	PA.9	I/O	MFP0	General purpose digital I/O pin.
			I2C0_SCL	I/O	MFP1	I2C0 clock pin.
			TM1_CNT	I	MFP2	Timer1 event counter input.
			SC0_DAT	I/O	MFP3	SmartCard0 data pin.
			SPI2_CLK	I/O	MFP4	SPI2 serial clock pin.
			TM1_OUT	O	MFP5	Timer1 toggle output.
			UART1_nRTS	O	MFP6	UART1 Request to Send output pin.
			SNOOPER	I	MFP7	Snooper pin.
6	4	-	PA.11	I/O	MFP0	General purpose digital I/O pin.
			I2C1_SCL	I/O	MFP1	I2C1 clock pin.
			TM3_CNT	I	MFP2	Timer3 event counter input.
			SC0_RST	O	MFP3	SmartCard0 reset pin.
			SPI2_MOSI0	I/O	MFP4	SPI2 1 st MOSI (Master Out, Slave In) pin.
			TM3_OUT	O	MFP5	Timer3 toggle output.

Pin No.			Pin Name	Pin Type	MFP*	Description
64-pin	48-pin	32-pin				
7	5	-	PA.10	I/O	MFP0	General purpose digital I/O pin.
			I2C1_SDA	I/O	MFP1	I2C1 data input/output pin.
			TM2_CNT	I	MFP2	Timer2 event counter input.
			SC0_PWR	O	MFP3	SmartCard0 power pin.
			SPI2_MISO0	I/O	MFP4	SPI2 1 st MISO (Master In, Slave Out) pin.
			TM2_OUT	O	MFP5	Timer2 toggle output.
8	6	-	PA.9	I/O	MFP0	General purpose digital I/O pin.
			I2C0_SCL	I/O	MFP1	I2C0 clock pin.
			TM1_CNT	I	MFP2	Timer1 event counter input.
			SC0_DAT	I/O	MFP3	SmartCard0 data pin.
			SPI2_CLK	I/O	MFP4	SPI2 serial clock pin.
			TM1_OUT	O	MFP5	Timer1 toggle output.
			UART1_nRTS	O	MFP6	UART1 Request to Send output pin.
			SNOOPER	I	MFP7	Snooper pin.
9	7	3	PA.8	I/O	MFP0	General purpose digital I/O pin.
			I2C0_SDA	I/O	MFP1	I2C0 data input/output pin.
			TM0_CNT	I	MFP2	Timer0 event counter input.
			SC0_CLK	O	MFP3	SmartCard0 clock pin.
			SPI2_SS0	I/O	MFP4	SPI2 1 st slave select pin.
			TM0_OUT	O	MFP5	Timer0 toggle output.
			UART1_nCTS	I	MFP6	UART1 Clear to Send input pin.
10	8	4	PB.4	I/O	MFP0	General purpose digital I/O pin.
			UART1_RXD	I	MFP1	Data receiver input pin for UART1.
			SC0_CD	I	MFP3	SmartCard0 card detect pin.
			SPI2_SS0	I/O	MFP4	SPI2 1 st slave select pin.
			RTC_HZ	O	MFP6	RTC 1Hz output.
11	9	5	PB.5	I/O	MFP0	General purpose digital I/O pin.
			UART1_TXD	O	MFP1	Data transmitter output pin for UART1.
			SC0_RST	O	MFP3	SmartCard0 reset pin.
			SPI2_CLK	I/O	MFP4	SPI2 serial clock pin.
12	-	-	PB.6	I/O	MFP0	General purpose digital I/O pin.
			UART1_RSTn	O	MFP1	UART1 Request to Send output pin.
			SPI2_MISO0	I/O	MFP4	SPI2 1 st MISO (Master In, Slave Out) pin.

Pin No.			Pin Name	Pin Type	MFP*	Description
64-pin	48-pin	32-pin				
13	-	-	PB.7	I/O	MFP0	General purpose digital I/O pin.
			UART1_nCTS	I	MFP1	UART1 Clear to Send input pin.
			SPI2_MOSI0	I/O	MFP4	SPI2 ^{1st} MOSI (Master Out, Slave In) pin.
14	10	6	LDO_CAP	AO	MFP0	LDO output pin.
15	11	7	V _{DD}	P	MFP0	Power supply for I/O ports and LDO source for internal PLL and digital function.
16	12	8	V _{SS}	G	MFP0	Ground pin for digital circuit.
17	13	9	PB.0	I/O	MFP0	General purpose digital I/O pin.
			UART0_RXD	I	MFP1	Data receiver input pin for UART0.
			SPI1_MOSI0	I/O	MFP3	SPI1 ^{1st} MOSI (Master Out, Slave In) pin.
18	14	10	PB.1	I/O	MFP0	General purpose digital I/O pin.
			UART0_TXD	O	MFP1	Data transmitter output pin for UART0.
			SPI1_MISO0	I/O	MFP3	SPI1 ^{1st} MISO (Master In, Slave Out) pin.
19	15	11	PB.2	I/O	MFP0	General purpose digital I/O pin.
			UART0_nRTS	O	MFP1	UART0 Request to Send output pin.
			SPI1_CLK	I/O	MFP3	SPI1 serial clock pin.
			CLKO	O	MFP4	Frequency Divider output pin.
20	16	12	PB.3	I/O	MFP0	General purpose digital I/O pin.
			UART0_nCTS	I	MFP1	UART0 Clear to Send input pin.
			SPI1_SS0	I/O	MFP3	SPI1 1 st slave select pin.
			SC1_CD	I	MFP4	SmartCard1 card detect pin.
21	-	-	PD.6	I/O	MFP0	General purpose digital I/O pin.
			SPI1_MOSI1	I/O	MFP3	SPI1 2 nd MOSI (Master Out, Slave In) pin.
			SC1_RST	O	MFP4	SmartCard1 reset pin.
22	-	-	PD.7	I/O	MFP0	General purpose digital I/O pin.
			SPI1_MISO1	I/O	MFP3	SPI1 2 nd MISO (Master In, Slave Out) pin.
			SC1_PWR	O	MFP4	SmartCard1 power pin.
23	-	-	PD.14	I/O	MFP0	General purpose digital I/O pin.
			SPI0_MOSI1	I/O	MFP1	SPI0 2 nd MOSI (Master Out, Slave In) pin.
			SC1_DAT	I/O	MFP4	SmartCard1 data pin.
24	-	-	PD.15	I/O	MFP0	General purpose digital I/O pin.
			SPI0_MISO1	I/O	MFP1	SPI0 2 nd MISO (Master In, Slave Out) pin.
			SC1_CLK	O	MFP4	SmartCard1 clock pin.
25	17	13	PC.3	I/O	MFP0	General purpose digital I/O pin.

Pin No.			Pin Name	Pin Type	MFP*	Description
64-pin	48-pin	32-pin				
			SPI0_MOSI0	I/O	MFP1	SPI0 1 st MOSI (Master Out, Slave In) pin.
			SC1_RST	O	MFP4	SmartCard1 reset pin.
			PWM0_BRAKE0	I	MFP5	PWM0 Brake0 input pin .
26	18	14	PC.2	I/O	MFP0	General purpose digital I/O pin.
			SPI0_MISO0	I/O	MFP1	SPI0 1st MISO (Master In, Slave Out) pin.
			SC1_PWR	O	MFP4	SmartCard1 power pin.
			PWM0_BRAKE1	I	MFP5	PWM0 Brake1 input pin.
27	19	15	PC.1	I/O	MFP0	General purpose digital I/O pin.
			SPI0_CLK	I/O	MFP1	SPI0 serial clock pin.
			SC1_DAT	I/O	MFP4	SmartCard1 data pin.
			PWM0_BRAKE0	I	MFP5	PWM0 Brake0 input pin.
28	20	16	PC.0	I/O	MFP0	General purpose digital I/O pin.
			SPI0_SS0	I/O	MFP1	SPI0 1 st slave select pin.
			SC1_CLK	O	MFP4	SmartCard1 clock pin.
			PWM0_BRAKE1	I	MFP5	PWM0 Brake1 input pin..
29	21	-	PE.5	I/O	MFP0	General purpose digital I/O pin.
			PWM0_CH5	I/O	MFP1	PWM0 channel5 output/capture input.
			RTC_HZ	O	MFP6	RTC 1Hz output.
30	22	-	PB.11	I/O	MFP0	General purpose digital I/O pin.
			PWM0_CH4	I/O	MFP1	PWM0 channel4 output/capture input.
			TM3_CNT	I	MFP2	Timer3 event counter input.
			TM3_OUT	O	MFP4	Timer3 toggle output.
			SPI0_MISO0	I/O	MFP5	SPI0 1 st MISO (Master In, Slave Out) pin.
31	23	-	PB.10	I/O	MFP0	General purpose digital I/O pin.
			SPI0_MOSI0	I/O	MFP1	SPI0 1 st MOSI (Master Out, Slave In) pin.
			TM2_CNT	I	MFP2	Timer2 event counter input.
			TM2_OUT	O	MFP4	Timer2 toggle output.
			SPI0_SS1	I/O	MFP5	SPI0 2 nd slave select pin.
32	24	-	PB.9	I/O	MFP0	General purpose digital I/O pin.
			SPI1_SS1	I/O	MFP1	SPI1 1 st slave select pin.
			TM1_CNT	I	MFP2	Timer1 event counter input.
			TM1_OUT	O	MFP4	Timer1 toggle output.
			INT0	I	MFP5	External interrupt0 input pin.

Pin No.			Pin Name	Pin Type	MFP*	Description
64-pin	48-pin	32-pin				
33	-	-	PC.11	I/O	MFP0	General purpose digital I/O pin.
			SPI1_MOSI0	I/O	MFP1	SPI1 1 st MOSI (Master Out, Slave In) pin.
			UART1_TXD	O	MFP5	Data transmitter output pin for UART1.
34	-	-	PC.10	I/O	MFP0	General purpose digital I/O pin.
			SPI1_MISO0	I/O	MFP1	SPI1 1 st MISO (Master In, Slave Out) pin.
			UART1_RXD	I	MFP5	Data receiver input pin for UART1.
35	-	-	PC.9	I/O	MFP0	General purpose digital I/O pin.
			SPI1_CLK	I/O	MFP1	SPI1 serial clock pin.
			I2C1_SCL	I/O	MFP5	I2C1 clock pin.
36	-	-	PC.8	I/O	MFP0	General purpose digital I/O pin.
			SPI1_SS0	I/O	MFP1	SPI1 1 st slave select pin.
			I2C1_SDA	I/O	MFP5	I2C1 data input/output pin.
37	25	17	PA.15	I/O	MFP0	General purpose digital I/O pin.
			PWM0_CH3	I/O	MFP1	PWM0 channel3 output/capture input.
			I2C1_SCL	I/O	MFP2	I2C1 clock pin.
			TM3_EXT	I	MFP3	Timer3 external capture input.
			SC0_PWR	O	MFP4	SmartCard0 power pin.
			TM3_CNT	I	MFP5	Timer3 event counter input.
			UART0_TXD	O	MFP6	Data transmitter output pin for UART0.
			TM3_OUT	O	MFP7	Timer3 toggle output.
38	26	18	PA.14	I/O	MFP0	General purpose digital I/O pin.
			PWM0_CH2	I/O	MFP1	PWM0 channel2 output/capture input.
			I2C1_SDA	I/O	MFP2	I2C1 data input/output pin.
			TM2_EXT	I	MFP3	Timer2 external capture input.
			TM2_CNT	I	MFP5	Timer2 event counter input.
			UART0_RXD	I	MFP6	Data receiver input pin for UART0.
			TM2_OUT	O	MFP7	Timer2 toggle output.
39	27	-	PA.13	I/O	MFP0	General purpose digital I/O pin.
			PWM0_CH1	I/O	MFP1	PWM0 channel1 output/capture input.
			TM1_EXT	I	MFP3	Timer1 external capture input.
			I2C0_SCL	I/O	MFP5	I2C0 clock pin.
40	28	-	PA.12	I/O	MFP0	General purpose digital I/O pin.
			PWM0_CH0	I/O	MFP1	PWM0 channel0 output/capture input.

Pin No.			Pin Name	Pin Type	MFP*	Description
64-pin	48-pin	32-pin				
			TM0_EXT	I	MFP3	Timer0 external capture input.
			I2C0_SDA	I/O	MFP5	I2C0 data input/output pin.
41	29	19	PF.0	I/O	MFP0	General purpose digital I/O pin.
			INT0	I	MFP5	External interrupt0 input pin.
			ICE_DAT	I/O	MFP7	Serial wired debugger data pin
42	30	20	PF.1	I/O	MFP0	General purpose digital I/O pin.
			CLKO	O	MFP4	Frequency Divider output pin.
			INT1	I	MFP5	External interrupt1 input pin.
			ICE_CLK	I	MFP7	Serial wired debugger clock pin.
43	31	-	AV _{SS}	G	MFP0	Ground pin for analog circuit.
44	32	21	PA.0	I/O	MFP0	General purpose digital I/O pin.
			ADC_CH0	AI	MFP1	ADC analog input0.
			ACMP0_P	AI	MFP2	Comparator0 P-end input.
			TM2_EXT	I	MFP3	Timer2 external capture input.
			PWM0_CH2	I/O	MFP5	PWM0 channel2 output/capture input.
			SPI3_MOSI1	I/O	MFP6	SPI3 2 nd MOSI (Master Out, Slave In) pin.
45	33	-	PA.1	I/O	MFP0	General purpose digital I/O pin.
			ADC_CH1	AI	MFP1	ADC analog input1.
			ACMP0_N	AI	MFP2	Comparator0 N-end input.
			SPI3_MISO1	I/O	MFP6	SPI3 2 nd MISO (Master In, Slave Out) pin.
46	34	22	PA.2	I/O	MFP0	General purpose digital I/O pin.
			ADC_CH2	AI	MFP1	ADC analog input2.
			UART1_RXD	I	MFP5	Data receiver input pin for UART1.
47	35	23	PA.3	I/O	MFP0	General purpose digital I/O pin.
			ADC_CH3	AI	MFP1	ADC analog input3.
			UART1_TXD	O	MFP5	Data transmitter output pin for UART1.
			SPI3_MOSI0	I/O	MFP6	SPI3 1 st MOSI (Master Out, Slave In) pin.
48	36	24	PA.4	I/O	MFP0	General purpose digital I/O pin.
			ADC_CH4	AI	MFP1	ADC analog input4.
			I2C0_SDA	I/O	MFP5	I2C0 data input/output pin.
			SPI3_MISO0	I/O	MFP6	SPI3 1 st MISO (Master In, Slave Out) pin.
49	37	25	PA.5	I/O	MFP0	General purpose digital I/O pin.
			ADC_CH5	AI	MFP1	ADC analog input5.

Pin No.			Pin Name	Pin Type	MFP*	Description
64-pin	48-pin	32-pin				
			I2C0_SCL	I/O	MFP5	I2C0 clock pin.
			SPI3_SCLK	I/O	MFP6	SPI3 serial clock pin.
50	38	26	PA.6	I/O	MFP0	General purpose digital I/O pin.
			ADC_CH6	AI	MFP1	ADC analog input6.
			ACMP0_O	O	MFP2	Comparator0 output.
			TM3_EXT	I	MFP3	Timer3 external capture input.
			TM3_CNT	I	MFP4	Timer3 event counter input.
			PWM0_CH3	I/O	MFP5	PWM0 channel3 output/capture input.
			SPI3_SS0	I/O	MFP6	SPI3 1 st slave select pin.
			TM3_OUT	O	MFP7	Timer3 toggle output.
51	39	-	VREF	I	MFP0	Voltage reference input for ADC.
52	40	27	AV _{DD}	AP	MFP0	Power supply for internal analog circuit.
53	41	-	PC.7	I/O	MFP0	General purpose digital I/O pin.
			UART1_TXD	O	MFP1	Data transmitter output pin for UART1.
			ADC_CH7	AI	MFP2	ADC analog input7.
			TM1_EXT	I	MFP3	Timer1 external capture input.
			PWM0_CH1	I/O	MFP5	PWM0 channel1 output/capture input.
54	42	-	PC.6	I/O	MFP0	General purpose digital I/O pin.
			UART1_RXD	I	MFP1	Data receiver input pin for UART1.
			TM0_EXT	I	MFP3	Timer0 external capture input.
			SC1_CD	I	MFP4	SmartCard1 card detect pin.
			PWM0_CH0	I/O	MFP5	PWM0 channel0 output/capture input.
55	-	-	PC.15	I/O	MFP0	General purpose digital I/O pin.
			UART1_nRTS	O	MFP1	UART1 Request to Send output pin.
			TM0_EXT	I	MFP3	Timer0 external capture input.
56	-	-	PC.14	I/O	MFP0	General purpose digital I/O pin.
			UART1_nCTS	I	MFP1	UART1 Clear to Send input pin.
57	43	-	PB.15	I/O	MFP0	General purpose digital I/O pin.
			INT1	I	MFP1	External interrupt1 input pin.
			SNOOPER	I	MFP3	Snooper pin.
			SC1_CD	I	MFP4	SmartCard1 card detect pin.
58	44	28	PF.3	I/O	MFP0	General purpose digital I/O pin.
			XT1_IN	I	MFP7	External 4~24 MHz (high speed) crystal input pin.

Pin No.			Pin Name	Pin Type	MFP*	Description
64-pin	48-pin	32-pin				
59	45	29	PF.2	I/O	MFP0	General purpose digital I/O pin.
			XT1_OUT	O	MFP7	External 4~24 MHz (high speed) crystal output pin.
60	46	30	nRESET	I	MFP0	External reset input: active LOW, with an internal pull-up. Set this pin low reset to initial state.
61	-	-	V _{SS}	G	MFP0	Ground pin for digital circuit.
62	-	-	V _{DD}	P	MFP0	Power supply for I/O ports and LDO source for internal PLL and digital function.
63	47	-	V _{SS}	G	MFP0	Ground pin for digital circuit.
64	48	-	PB.8	I/O	MFP0	General purpose digital I/O pin.
			STADC	I	MFP1	ADC external trigger input.
			TM0_CNT	I	MFP2	Timer0 event counter input.
			INT0	I	MFP3	External interrupt0 input pin.
			TM0_OUT	O	MFP4	Timer0 toggle output.
			SNOOPER	I	MFP7	Snooper pin.

Note: Pin Type: I = Digital Input, O=Digital Output; AI = Analog Input; AO = Analog Output; P = Power Pin; AP = Analog Power.

5 BLOCK DIAGRAM

5.1 Nano103 Block Diagram

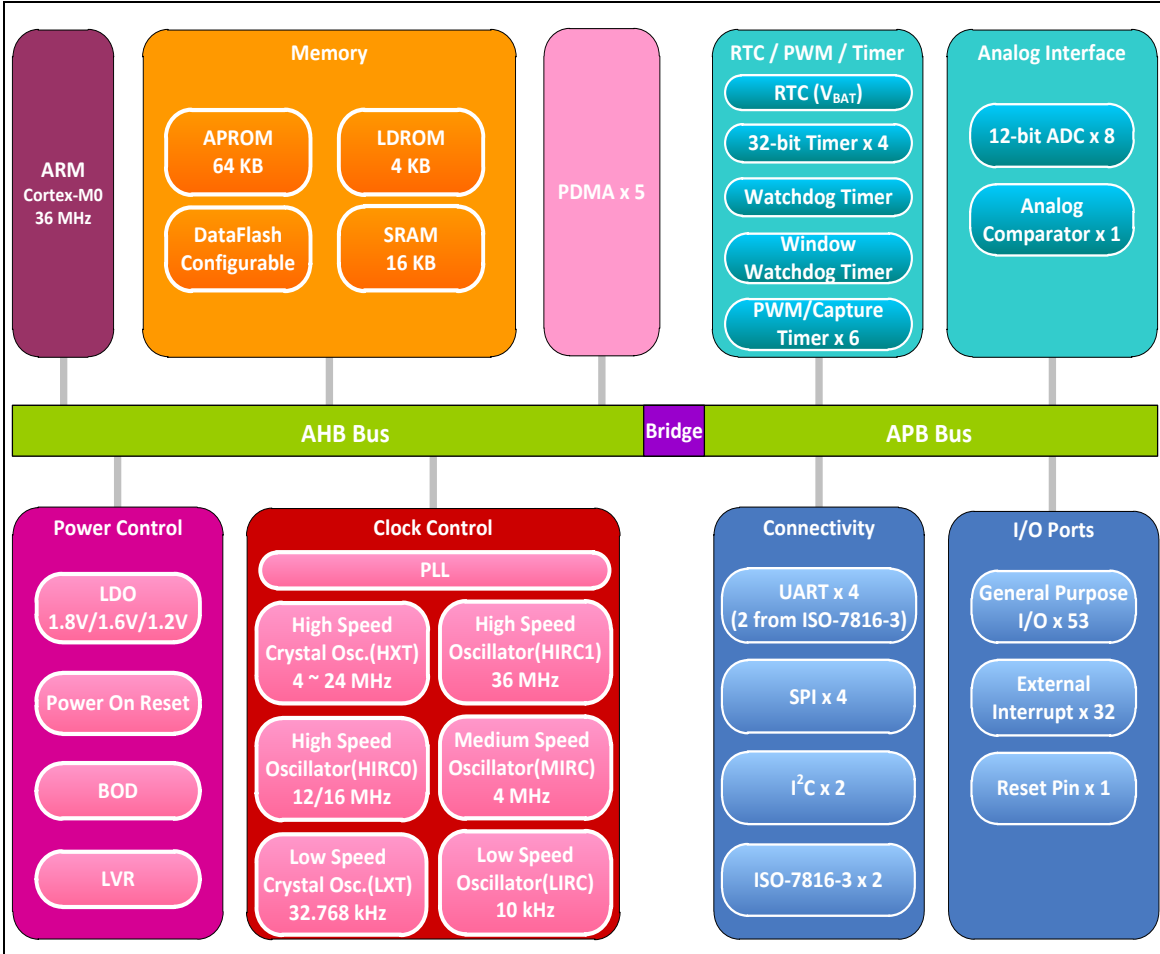

Figure 5.1-1 NuMicro[®] Nano103 Block Diagram

6 FUNCTIONAL DESCRIPTION

6.1 ARM® Cortex®-M0 Core

The Cortex®-M0 processor is a configurable, multistage, 32-bit RISC processor, which has an AMBA AHB-Lite interface and includes an NVIC component. It also has optional hardware debug functionality. The processor can execute Thumb code and is compatible with other Cortex®-M profile processor. The profile supports two modes –Thread mode and Handler mode. Handler mode is entered as a result of an exception. An exception return can only be issued in Handler mode. Thread mode is entered on Reset, and can be entered as a result of an exception return. The Figure 6.1-1 shows the functional controller of processor.

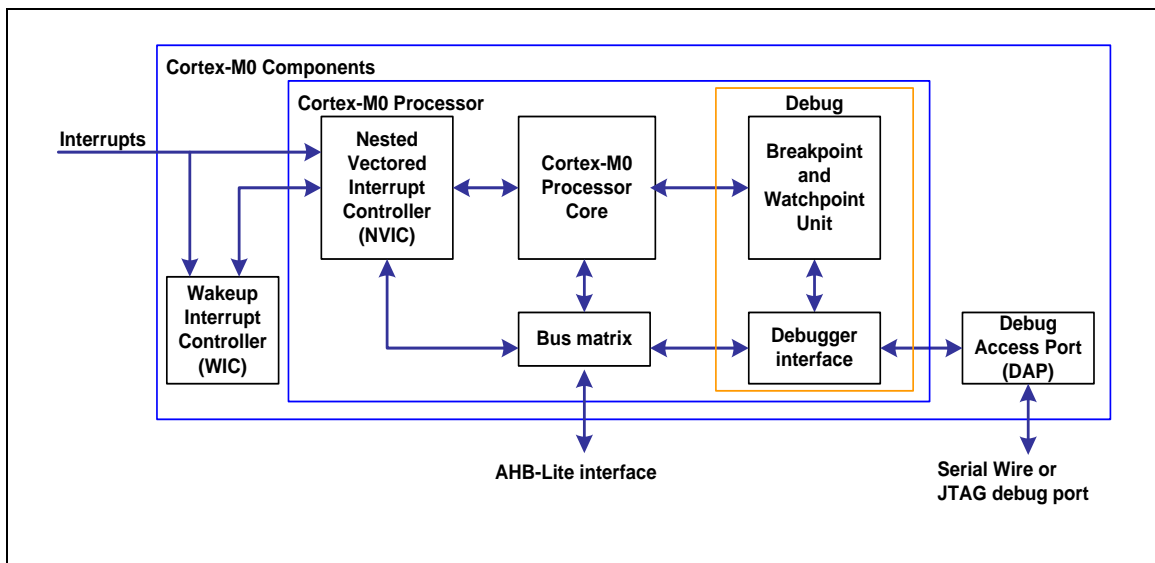

Figure 6.1-1 Functional Block Diagram

The implemented device provides:

- A low gate count processor:
 - ARMv6-M Thumb® instruction set
 - Thumb-2 technology
 - ARMv6-M compliant 24-bit SysTick timer
 - A 32-bit hardware multiplier
 - System interface supported with little-endian data accesses
 - Ability to have deterministic, fixed-latency, interrupt handling
 - Load/store-multiples and multicycle-multiplies that can be abandoned and restarted to facilitate rapid interrupt handling
 - C Application Binary Interface compliant exception model. This is the ARMv6-M, C Application Binary Interface (C-ABI) compliant exception model that enables the use of pure C functions as interrupt handlers
 - Low Power Sleep mode entry using the Wait For Interrupt (WFI), Wait For Event (WFE) instructions, or return from interrupt sleep-on-exit feature
- NVIC:
 - 32 external interrupt inputs, each with four levels of priority
 - Dedicated Non-maskable Interrupt (NMI) input
 - Supports for both level-sensitive and pulse-sensitive interrupt lines

- Supports Wake-up Interrupt Controller (WIC) and, providing Ultra-low Power Sleep mode
- Debug support:
 - Four hardware breakpoints
 - Two watchpoints
 - Program Counter Sampling Register (PCSR) for non-intrusive code profiling
 - Single step and vector catch capabilities
- Bus interfaces:
 - Single 32-bit AMBA-3 AHB-Lite system interface that provides simple integration to all system peripherals and memory
 - Single 32-bit slave port that supports the DAP (Debug Access Port)

6.2 System Manager

6.2.1 Overview

The system manager provides the functions of power modes, wake-up sources, power architecture, reset sources, scalable LDO, system memory map, product ID and multi-function pin control.

6.2.2 Features

- Power modes and wake-up sources
- System power architecture
- Reset sources
- Scalable LDO
- HIRC0, HIRC1, and MIRC Auto-trim
- System memory map
- System manager Control registers map
- System timer (SysTick)
- System control register
- Nested vectored interrupt controller (NVIC)

6.3 Clock Controller

6.3.1 Overview

The clock controller generates clocks for the whole chip, including system clocks and all peripheral clocks. The clock controller also implements the power control function with the individually clock ON/OFF control, clock source selection and a clock divider. The chip will not enter Power-down mode until CPU sets the Power-down enable bit PDEN(CLK_PWRCTL[6]) and Cortex[®]-M0 core executes the WFI instruction. After that, chip enters Power-down mode and wait for wake-up interrupt source triggered to leave Power-down mode. In Power-down mode, the clock controller turns off the 4~24 MHz external high speed crystal (HXT), 12~16 MHz internal high speed RC oscillator (HIRC0), 36 MHz internal high speed RC oscillator (HIRC1), and 4 MHz internal medium speed RC oscillator (MIRC) to reduce the overall system power consumption. The following figure shows the clock generator and the overview of the clock source control.

The clock controller consists of 7 sources as listed below:

- 32768 Hz external low speed crystal oscillator (LXT)
- 4~24 MHz external high speed crystal oscillator (HXT)
- 12~16 MHz internal high speed RC oscillator (HIRC0)
- 36 MHz internal high speed RC oscillator (HIRC1)
- 4 MHz internal medium speed RC oscillator (MIRC)
- One programmable PLL FOUT (PLL source can be selected from HXT, HIRC0,HIRC1 or MIRC)
- 10 kHz internal low speed RC oscillator (LIRC)

6.3.2 Features

- Generates clocks for system clocks and all peripheral module clocks.
- Each peripheral module clock can be turned on/off.
- In Power-down mode, the clock controller turns off the external high speed crystal (HXT) and internal high speed RC oscillator (HIRC0,HIRC1 and MIRC) to reduce the overall system power consumption.

6.4 Flash Memory Controller (FMC)

6.4.1 Overview

The Nano103 series is equipped with 64 KB on-chip embedded flash for application and Data Flash to store some application dependent data. A User Configuration block provides for system initiation. A 4K bytes loader ROM (LDROM) is used for In-System-Programming (ISP) function. This chip also supports In-Application-Programming (IAP) function, user switches the code executing without the chip reset after the embedded flash updated.

6.4.2 Features

- Supports 64 KB application ROM (APROM).
- Supports 4 KB loader ROM (LDROM).
- Supports Data Flash with configurable memory size.
- Supports 12 bytes User Configuration block to control system initiation.
- Supports 512 bytes page erase for all embedded flash.
- Supports fast flash programming verification function.
- Supports CRC-32 checksum calculation function.
- Supports Flash All-One verification function.
- Supports In-System-Programming (ISP) /In-Application-Programming (IAP) to update embedded flash memory.
- Supports cache memory to improve flash access performance and reduce power consumption.

6.5 General Purpose I/O Controller

6.5.1 Overview

The Nano103 series has up to 53 General Purpose I/O pins to be shared with other function pins depending on the chip configuration. These 53 pins are arranged in 6 ports named as PA, PB, PC, PD, PE and PF. The PA, PB, PC, PD and PE have 16 pins on port, and the PF has 8 pins on port. Each of the 53 pins is independent and has the corresponding register bits to control the pin mode function and data.

The I/O type of each I/O pin can be configured by software individually as Input, Push-pull output, and Open-drain output. Each I/O pin has a very weak individual pull-up resistor which is about 110 k Ω ~40 k Ω and V_{DD} is from 2.2 V to 3.6 V.

6.5.2 Features

- Three I/O modes:
 - ◆ Schmitt trigger Input-only with high impedance
 - ◆ Push-Pull Output mode
 - ◆ Open-Drain Output mode
- I/O pin can be configured as interrupt source with edge/level setting
- Enabling the pin interrupt function will also enable the wake-up function

6.6 PDMA Controller (PDMA)

6.6.1 Overview

The peripheral direct memory access (PDMA) controller in the Nano103 series contains a four-channel DMA controller and a cyclic redundancy check (CRC) generator.

The PDMA controller is used to provide high-speed data transfer. The PDMA controller can transfer data from one address to another without CPU intervention. This has the benefit of reducing the workload of CPU and keeps CPU resources free for other applications. The PDMA controller has a total of 4 channels and each channel can perform transfer between memory and peripherals or between memory and memory.

The PDMA controller also contains a cyclic redundancy check (CRC) generator that can perform CRC calculation with programmable polynomial settings. The CRC engine supports CPU mode and DMA transfer mode.

6.6.2 Features

- Supports 4 independently configurable channels and 1 CRC channel
- Supports hardware round robin priority scheme. PDMA channel 1 has the highest priority and channel 4 has the lowest priority
- PDMA
 - ◆ Supports transfer data width of 8, 16, or 32 bits
 - ◆ Supports software and SPI, UART, TIMER and ADC request
 - ◆ Supports source and destination address increment size can be byte, half-word, word, no increment or wrap around
 - ◆ Supports periodic transfer count interrupt
 - ◆ Supports time-out function for each channel
- Cyclic Redundancy Check (CRC)
 - ◆ Supports four common polynomials CRC-CCITT, CRC-8, CRC-16, and CRC-32
 - CRC-CCITT: $X^{16} + X^{12} + X^5 + 1$
 - CRC-8: $X^8 + X^2 + X + 1$
 - CRC-16: $X^{16} + X^{15} + X^2 + 1$
 - CRC-32: $X^{32} + X^{26} + X^{23} + X^{22} + X^{16} + X^{12} + X^{11} + X^{10} + X^8 + X^7 + X^5 + X^4 + X^2 + X + 1$
 - ◆ Programmable seed value
 - ◆ Supports programmable order reverse setting for input data and CRC checksum
 - ◆ Supports programmable 1's complement setting for input data and CRC checksum
 - ◆ Supports CPU mode or DMA transfer mode
 - ◆ Supports transfer data width of 8, 16, or 32 bits in CRC CPU mode
 - 8-bit write mode: 1-AHB clock cycle operation
 - 16-bit write mode: 2-AHB clock cycle operation
 - 32-bit write mode: 4-AHB clock cycle operation

- ◆ Supports transfer data width of 8 bits in CRC DMA mode

6.7 Timer Controller

6.7.1 Overview

The timer controller includes four 32-bit timers, Timer0 ~ Timer3, allowing user to easily implement a timer control applications. The timer can perform functions, such as frequency measurement, delay timing, clock generation, and event counting by external input pins, and interval measurement by external capture pins.

6.7.2 Features

- Four sets of 32-bit timers with 24-bit up counter and one 8-bit prescale counter
- Independent Clock Source for each Timer
- Provides one-shot, periodic, toggle-output and continuous counting operation modes
- 24-bit up counter value is readable through CNT (TIMERx_CNT[23:0])
- Supports event counting function to count input event from pin TMx_CNT (x = 0~3)
- 24-bit capture value is readable through CAPDAT (TIMERx_CAP[23:0])
- Supports event capture from external pin TMx_EXT (x = 0~3) for interval measurement
- Supports event capture from external pin TMx_EXT (x = 0~3) to reset 24-bit up counter
- Supports chip wake-up from Idle/Power-down mode if a timer interrupt signal is generated
- Supports time-out interrupt or capture interrupt to trigger ADC, PDMA and PWM.
- Supports Inter-Timer trigger that Timer 0 can trigger Timer 1 and Timer 2 can trigger Timer 3

6.8 PWM Generator and Capture Timer (PWM)

6.8.1 Overview

The Nano103 provides one PWM generator – PWM0. The PWM0 supports 6 channels for PWM0 output or input capture. There is a 12-bit prescaler to support flexible clock to the 16-bit PWM0 counter with 16-bit comparator. The PWM0 counter supports up, down and up-down counter types and uses a comparator compared with counter to generate events. These events are used to generate PWM0 pulse, interrupt and trigger signal for ADC to start conversion.

The PWM0 generator supports two standard PWM0 output modes: Independent mode and Complementary mode, which have different architecture. In Complementary mode, there are two comparators that generate various PWM0 pulse with 12-bit dead-time generator. The PWM0 output control unit supports polarity output, independent pin mask, tri-state output enable and brake functions.

The PWM0 generator also supports input capture function. It supports latch PWM0 counter value to a corresponding register when input channel has a rising transition, falling transition or both transitions.

6.8.2 Features

6.8.2.1 PWM0 function features

- Supports one PWM0 module to provides 6 output channels
- Supports independent mode for PWM0 output/Capture input channel
- Supports complementary mode for 3 complementary paired PWM0 output channel
 - ◆ Dead-time insertion with 12-bit resolution
 - ◆ Two compared values during one period
- Supports 12-bit pre-scalar from 1 to 4096
- Supports 16-bit resolution PWM0 counter, each module provides 3 PWM0 counters
 - ◆ Up, down and up/down counter operation type
- Supports mask function and tri-state enable for each PWM0 pin
- Supports brake function
 - ◆ Brake source from pin and system safety events (Brown-out detection and CPU lockup)
 - ◆ Noise filter for brake source from pin
 - ◆ Edge detect brake source to control brake state until brake interrupt cleared
 - ◆ Level detect brake source to auto recover function after brake condition removed
- Supports interrupt on the following events:
 - ◆ PWM0 counter match zero, period value or compared value
 - ◆ Brake condition happened
- Supports trigger ADC on the following events:
 - ◆ PWM0 counter match zero, period value or compared value

6.8.2.2 *Capture Function Features*

- Supports up to 12 capture input channels with 16-bit resolution
- Supports rising or falling capture condition
- Supports input rising/falling capture interrupt
- Supports rising/falling capture with counter reload option

6.9 Watchdog Timer Controller

6.9.1 Overview

The Watchdog Timer (WDT) is used to perform a system reset after system runs into an unknown state. This prevents system from hanging for an infinite period of time. Besides, this Watchdog Timer supports the function to wake-up CPU from Power-down mode. The watchdog timer includes an 18-bit free running up counter with programmable time-out intervals.

6.9.2 Features

- 18-bit free running up counter for Watchdog timer time-out interval.
- Selectable time-out interval (24 ~ 218) and the time-out interval is 1.6 ms ~ 26.214 s (if WDT_CLK = 10 kHz).
- System kept in reset state for a period of $(1 / \text{WDT_CLK}) * 63$.
- Supports selectable WDT reset delay period, including 1026、130、18 or 3 WDT_CLK reset delay period.
- Supports to force WDT enabled after chip powered on or reset by setting CWDT_EN[2:0] in Config0 register.
- Supports WDT time-out wake-up function only if WDT clock source is selected as LIRC or LXT.

6.10 Window Watchdog Timer Controller

6.10.1 Overview

The Window Watchdog Timer (WWDT) is used to perform a system reset within a specified window period to prevent software run to uncontrollable status by any unpredictable condition. The WWDT down counter value will stop to update when chip is in Idle or Power-down mode.

6.10.2 Features

- 6-bit down counter (WWDT_CNT) and 6-bit compare value (WINCMP) to make the WWDT time-out window period flexible
- Supports 4-bit value (PERIODSEL) to programmable maximum 11-bit prescale counter period of WWDT counter

6.11 Real Time Clock (RTC)

6.11.1 Overview

The Real Time Clock (RTC) controller provides the real time and calendar message. The RTC offers programmable time tick and alarm match interrupts. The data format of time and calendar messages are expressed in BCD format. A digital frequency compensation feature is available to compensate external crystal oscillator frequency accuracy.

The RTC controller also offers 80 bytes spare registers to store user's important information. The spare registers content is cleared when specified event on tamper pin is detected.

6.11.2 Features

- Supports real time counter in RTC_TIME (hour, minute, second) and calendar counter in RTC_CAL (year, month, day) for RTC time and calendar check
- Supports alarm time (hour, minute, second) and calendar (year, month, day) settings in RTC_TALM and RTC_CALM
- Supports alarm time (hour, minute, second) and calendar (year, month, day) mask enable in RTC_TAMSK and RTC_CAMSK
- Selectable 12-hour or 24-hour time scale in RTC_CLKFMT register
- Supports Leap Year indication in RTC_LEAPYEAR register
- Supports Day of the Week counter in RTC_WEEKDAY register
- Frequency of RTC clock source compensate by RTC_FREQADJ register
- All time and calendar message expressed in BCD format
- Supports periodic RTC Time Tick interrupt with 8 period interval options 1/128, 1/64, 1/32, 1/16, 1/8, 1/4, 1/2 and 1 second
- Supports RTC Time Tick and Alarm Match interrupt
- Supports chip wake-up from Idle or Power-down mode while a RTC interrupt signal is generated
- Supports 20 bytes spare registers and a snoop pin detection to clear the content of these spare registers

6.12 UART Controller

6.12.1 Overview

The UART Controller provides up to two channels of Universal Asynchronous Receiver/Transmitter (UART). The UART Controller performs Normal Speed UART and supports flow control function. In addition, the UART Controller performs a serial-to-parallel conversion on data received from the peripheral and a parallel-to-serial conversion on data transmitted from the CPU. Each UART Controller channel supports ten types of interrupts. The UART controller also supports IrDA SIR, LIN Master/Slave, RS-485 and auto-baud rate measuring function.

6.12.2 Features

- Full duplex asynchronous communications.
- Separate receiving and transmitting 16/16 bytes entry FIFO for data payloads.
- Supports hardware auto-flow control
- Supports programmable receiver buffer trigger level.
- Supports programmable baud rate generator for each channel individually.
- Supports nCTS, incoming RX data, RS-485 AAD mode address matched or received FIFO is equal to the RFITL to wake-up function.
- Supports 9-bit receiver buffer time-out detection function.
- Programmable transmitting data delay time between the last stop and the next start bit by setting DLY (UART_TOUT [15:8])
- Supports Auto-Baud Rate measurement and baud rate compensation
- Supports break error, frame error, parity error and receive/transmit buffer overflow detection function
- Fully programmable serial-interface characteristics
 - ◆ Programmable number of data bit, 5-, 6-, 7-, 8- bit character
 - ◆ Programmable parity bit, even, odd, no parity or stick parity bit generation and detection
 - ◆ Programmable stop bit, 1, 1.5, or 2 stop bit generation
- Supports IrDA SIR function mode
 - ◆ Supports for 3/16 bit duration for normal mode
- Supports LIN function mode
 - ◆ Supports LIN master/slave mode
 - ◆ Supports programmable break generation function for transmitter
 - ◆ Supports break detection function for receiver
- Supports RS-485 function mode
 - ◆ Supports RS-485 9-bit mode
 - ◆ Supports hardware or software enables to program nRTS pin to control RS-485 transmission direction
- All UART Controller can be served by the PDMA.

6.13 Smart Card Host Interface (SC)

6.13.1 Overview

The Smart Card Interface controller (SC controller) is based on ISO/IEC 7816-3 standard and fully compliant with PC/SC Specifications. It also can be set as UART mode to communicate with other device.

6.13.2 Features

- ISO-7816-3 T = 0, T = 1 compliant
- EMV2000 compliant
- Up to two ISO-7816-3 ports
- Separates receive/transmit 4 byte entry FIFO for data payloads
- Programmable transmission clock frequency
- Programmable receiver buffer trigger level
- Programmable guard time selection (11 ETU ~ 267 ETU)
- One 24-bit timer and two 8-bit timers for Answer to Request (ATR) and waiting times processing
- Supports auto inverse convention function
- Supports transmitter and receiver error retry and error number limitation function
- Supports hardware activation sequence process ,and the time between PWR on and CLK start is configurable
- Supports hardware warm reset sequence process
- Supports hardware deactivation sequence process
- Supports hardware auto deactivation sequence when detected the card removal
- Provides card insert/removal status
- Supports UART mode
 - ◆ Full duplex, asynchronous communications
 - ◆ Separates receiving / transmitting 4 bytes entry FIFO for data payloads
 - ◆ Supports programmable baud rate generator for each channel
 - ◆ Supports programmable receiver buffer trigger level
 - ◆ Programmable transmitting data delay time between the last stop bit leaving the TX-FIFO and the de-assertion by setting SC_EGTR register
 - ◆ Programmable even, odd or no parity bit generation and detection
 - ◆ Programmable stop bit, 1 or 2 stop bit generation

6.14 I²C Serial Interface Controller (I²C)

6.14.1 Overview

I²C is a two-wire, bi-directional serial bus that provides a simple and efficient method of data exchange between devices. The I²C standard is a true multi-master bus including collision detection and arbitration that prevents data corruption if two or more masters attempt to control the bus simultaneously.

There are two sets of I²C controllers which support Power-down wake-up function.

6.14.2 Features

The I²C bus uses two wires (SDA and SCL) to transfer information between devices connected to the bus. The main features of the I²C bus include:

- Supports up to two I2C ports
- Master/Slave mode
- Bidirectional data transfer between masters and slaves
- Multi-master bus (no central master)
- Arbitration between simultaneously transmitting masters without corruption of serial data on the bus
- Serial clock synchronization allow devices with different bit rates to communicate via one serial bus
- Built-in 14-bit time-out counter requesting the I2C interrupt if the I2C bus hangs up and timer-out counter overflows.
- Programmable clocks allow for versatile rate control
- Supports 7-bit addressing mode
- Supports multiple address recognition (two slave address with mask option)
- Supports Power-down wake-up function
- Supports two-level buffer
- Supports data transmit or receive directly mode.

6.15 SPI

6.15.1 Overview

The Serial Peripheral Interface (SPI) applies to synchronous serial data communication and allows full duplex transfer. Devices communicate in Master/Slave mode with the 4-wire bi-direction interface. It is used to perform a serial-to-parallel conversion on data received from a peripheral device, and a parallel-to-serial conversion on data transmitted to a peripheral device. The SPI controller can be configured as a master or a slave device.

The SPI controller supports wake-up function. When this chip stays in Power-down mode, it can be woken up by off-chip device.

The SPI controller supports 2-bit transfer mode to connect 2 off-chip slave devices and then perform full-duplex 2-bit data transfer. It also supports PDMA function to access the data buffer.

6.15.2 Features

- Up to four sets of SPI controllers
- Supports Master or Slave mode operation
- Supports 1 bit and 2 bit transfer mode
- Supports Dual I/O transfer mode
- Configurable bit length of a transaction word from 8 to 32-bit
- Supports MSB first or LSB first transfer sequence
- Two slave select lines supported in Master mode
- Configurable byte or word suspend mode
- Supports byte re-ordering function
- Provide separate 8-level depth transmit and receive FIFO buffer
- Supports wake-up function
- Supports PDMA transfer
- Supports 3-wires, no slave select signal, bi-direction interface

6.16 Analog to Digital Converter (ADC)

6.16.1 Overview

The Nano103 series contains one 12-bit successive approximation analog-to-digital converter (SAR A/D converter) with 8 external input channels and 6 internal channels. The A/D converter supports three operation modes: Single, Single-cycle Scan and Continuous Scan mode, and can be started by software, external STADC(PB.8) pin, timer event trigger and PWM trigger.

Note that the I/O pins used as ADC analog input pins must configure the Pin Function (SYS_GPA_MFPL/SYS_GPC_MFPL) to ADC input and off digital input path disable control (Px_DINOFF) should be turned on before ADC function is enabled.

6.16.2 Features

- Analog input voltage range: 0~VREF (Max to AVDD).
- Selectable 12-bit, 10-bit, 8-bit and 6-bit resolution.
- Supports sampling time settings for channel 0~7 individually and channel 12~17 share the same one sampling time setting.
- Supports two power saving modes:
 - ◆ Power-down mode.
 - ◆ Standby mode.
- Up to 8 external analog input channels (channel0 ~ channel7), and 6 internal channels (channel12 - channel17) converting six voltage sources (internal band-gap voltage, internal reference voltage, internal temperature sensor output, battery voltage, AVDD, and AVSS).
- Maximum ADC clock frequency is 36 MHz and each conversion needs 19 clocks and sampling time depending on the input resistance (Rin).
- Three operating modes:
 - ◆ Single mode: A/D conversion is performed one time on a specified channel.
 - ◆ Single-cycle Scan mode: A/D conversion is performed one cycle on all specified channels with the sequence from the lowest numbered channel to the highest numbered channel.
 - ◆ Continuous Scan mode: A/D converter continuously performs Single-cycle scan mode until software stops A/D conversion.
- An A/D conversion can be started by:
 - ◆ Software write 1 to SWTRG (ADC_CTL[11]) bit.
 - ◆ External pin STADC.
 - ◆ PWM trigger.
 - ◆ Selects one of four timer events to trigger ADC and transfer A/D results by PDMA.
- Each conversion result is held in data registers for each channel with valid and overrun indicators.
- Conversion results can be compared with specified value and user can select whether to generate an interrupt when conversion result matches the compare register setting.
- Supports calibration and load calibration words capability.

6.17 Analog Comparator Controller (ACMP0)

6.17.1 Overview

The Nano103 series contains one comparator. The comparator output is logic 1 when positive input is greater than negative input; otherwise, the output is 0. The comparator can be configured to generate an interrupt when the comparator output value changes.

6.17.2 Features

- Analog input voltage range: 0 ~ AVDD(voltage of AVDD pin)
- Supports hysteresis function
- Supports wake-up function
- Selectable input sources of negative input
- Comparator ACMP supports
 - ◆ 1 positive source
 - PA.0(ACMP0_P)
 - ◆ 4 negative sources
 - PA.1(ACMP0_N)
 - Comparator Reference Voltage (CRV)
 - Int_VREF
 - AGND

7 APPLICATION CIRCUIT

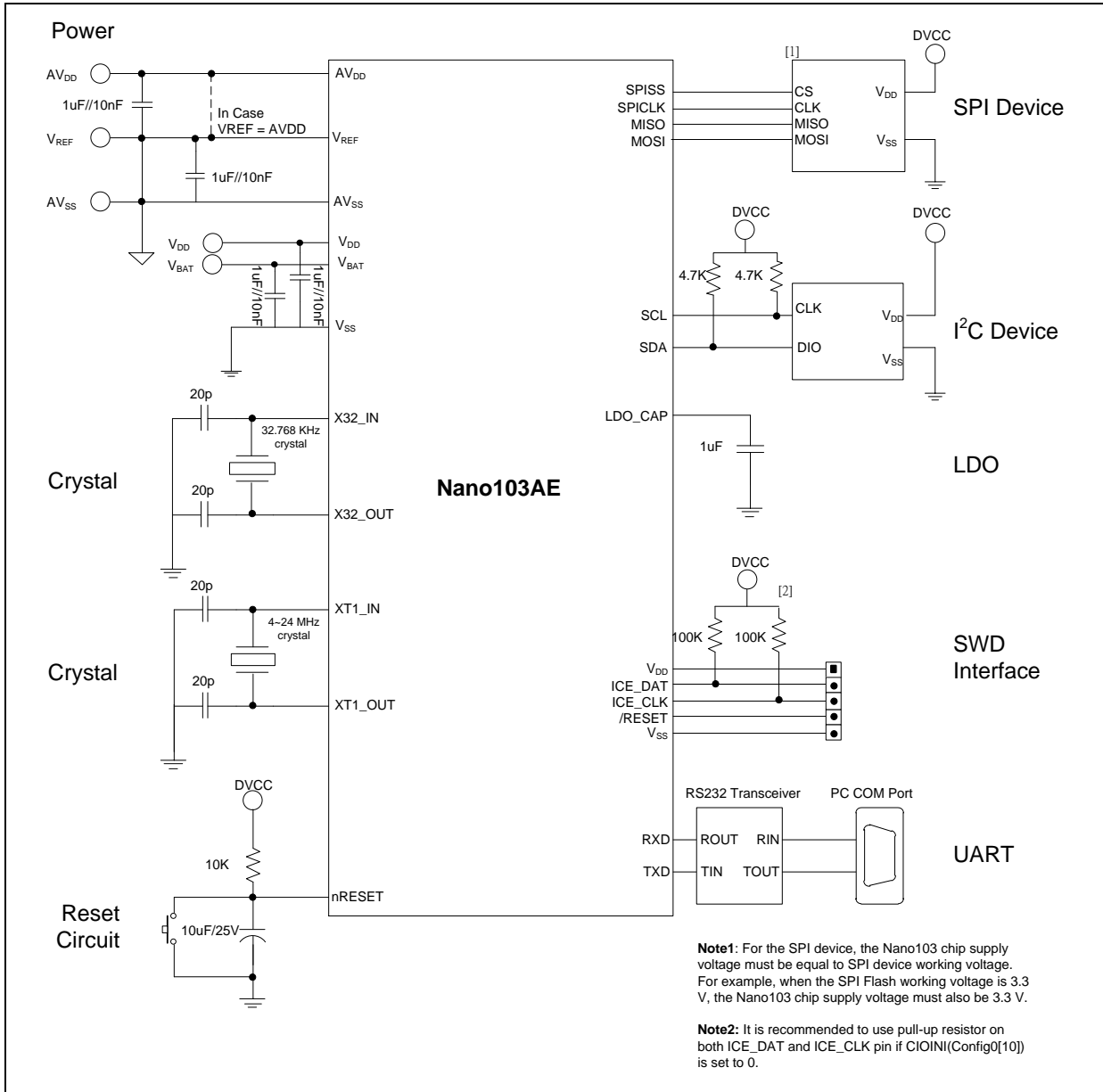

8 POWER COMSUMPTION

Part No	Test Condition	VDD	CPU clock	Current
Nano103 series	Operating Mode: CPU run while(1) in FLASH ROM Clock = 36MHz (from PLL and its clock source is 12 MHz Crystal Oscillator) Disable all peripheral Set LDO output = 1.8V	3.6V	36 MHz	6.7 mA 186 µA/MHz
	Idle Mode: CPU stop Clock = 36MHz (from PLL and its clock source is 12 MHz Crystal Oscillator) Disable all peripheral Set LDO output = 1.8V	3.6V	36 MHz	2.2 mA 61 µA/MHz
	Operating Mode: CPU run while(1) in FLASH ROM Clock = 36MHz Internal RC Oscillator Disable all peripheral Set LDO output = 1.8V	3.6V	36 MHz	6.7 mA 186 µA/MHz
	Idle Mode: CPU stop Clock = 36MHz Internal RC Oscillator Disable all peripheral Set LDO output = 1.8V	3.6V	36 MHz	1.9 mA 53 µA/MHz
	Operating Mode: CPU run while(1) in FLASH ROM Clock = 16MHz Crystal Oscillator Disable all peripheral Set LDO output = 1.6V	3.6V	16 MHz	2.9 mA 181 µA/MHz
	Idle Mode: CPU stop Clock = 16MHz Crystal Oscillator Disable all peripheral Set LDO output = 1.6V	3.6V	16 MHz	1.2 mA 75 µA/MHz
	Operating Mode: CPU run while(1) in FLASH ROM Clock = 36MHz Internal RC Oscillator Disable all peripheral Set LDO output = 1.6V	3.6V	16 MHz	2.8 mA 175 µA/MHz
	Idle Mode: CPU stop Clock = 36MHz Internal RC Oscillator Disable all peripheral Set LDO output = 1.6V	3.6V	16 MHz	1.1 mA 69 µA/MHz
	Operating Mode: CPU run while(1) in FLASH ROM Clock = 12MHz Crystal Oscillator Disable all peripheral Set LDO output = 1.6V	3.6V	12 MHz	2.2 mA 183 µA/MHz
	Idle Mode: CPU stop Clock = 12MHz Crystal Oscillator	3.6V	12 MHz	900 µA 75 µA/MHz

Disable all peripheral Set LDO output = 1.6V			
Operating Mode: CPU run while(1) in FLASH ROM Clock = 12MHz Internal RC Oscillator Disable all peripheral Set LDO output = 1.6V	3.6V	12 MHz	2.2 mA 183 μ A/MHz
Idle Mode: CPU stop Clock = 12MHz Internal RC Oscillator Disable all peripheral Set LDO output = 1.6V	3.6V	12 MHz	900 μ A 75 μ A/MHz
Operating Mode: CPU run while(1) in FLASH ROM Clock = 4MHz Crystal Oscillator Disable all peripheral Set LDO output = 1.2V	3.6V	4 MHz	600 μ A 150 μ A/MHz
Idle Mode: CPU stop Clock = 4MHz Crystal Oscillator Disable all peripheral Set LDO output = 1.2V	3.6V	4 MHz	500 μ A 125 μ A/MHz
Operating Mode: CPU run while(1) in FLASH ROM Clock = 4MHz Internal RC Oscillator Disable all peripheral Set LDO output = 1.2V	3.6V	4 MHz	900 μ A 225 μ A/MHz
Idle Mode: CPU stop Clock = 4MHz Internal RC Oscillator Disable all peripheral Set LDO output = 1.2V	3.6V	4 MHz	500 μ A 125 μ A/MHz
RTC Mode: (RAM retention) (Main power off and only V _{BAT} and RTC on) CPU stop Clock = 32.768KHz Crystal Oscillator Disable all peripheral except RTC circuit	3.6V	Stop	1 μ A
RTC Mode: (RAM retention) (Power down with LXT enable) CPU stop Clock = 32.768KHz Crystal Oscillator Disable all peripheral except RTC circuit Set LDO output = 1.2V	3.6V	Stop	2.1 μ A
Power Down Mode: (RAM retention) CPU and all clocks stop Set LDO output = 1.2V	3.6V	Stop	1.6 μ A

9 ELECTRICAL CHARACTERISTICS

9.1 Absolute Maximum Ratings

SYMBOL	PARAMETER	MIN	MAX	UNIT
DC Power Supply	$V_{DD}-V_{SS}$	-0.3	+3.6	V
Battery Power Supply	$V_{BAT}-V_{SS}$	-0.3	+3.6	V
Input Voltage on 5V Tolerance Pin	V_{IN}	$V_{SS} - 0.3$	5.5	V
Input Voltage on Any Other Pin without 5V Tolerance Pin	V_{IN}	$V_{SS} - 0.3$	$V_{DD} + 0.3$	V
Oscillator Frequency	$1/t_{CLCL}$	4	24	MHz
Operating Temperature	T_A	-40	+105	°C
Storage Temperature	T_{ST}	-55	+150	°C
Maximum Current into V_{DD}		-	150	mA
Maximum Current out of V_{SS}		-	150	mA
Maximum Current sunk by a I/O Pin		-	25	mA
Maximum Current Sourced by a I/O Pin		-	25	mA
Maximum Current Sunk by Total I/O Pins		-	100	mA
Maximum Current Sourced by Total I/O Pins		-	100	mA

Note: Output voltage for ADC/ACMP/HXT/LXT/PA.8/PB.4/PB.5 shared pins cannot be higher than V_{DD} because these pins are without 5V tolerance.

9.2 Nano103 DC Electrical Characteristics

(VDD-VSS=3.3V, TA = 25°C, FOSC = 36 MHz unless otherwise specified.)

PARAMETER	SYM.	SPECIFICATIONS				TEST CONDITIONS				
		MIN.	TYP.	MAX.	UNIT					
Operation Voltage	V _{DD}	2.2	-	3.6	V	V _{DD} = 2.2 V up to 36 MHz				
Power Ground	V _{SS} AV _{SS}	-0.3	-	-	V					
LDO Output Voltage	V _{LDO}	1.62	1.8	1.98	V	MCU operating in Run, Idle or Power-down mode				
		1.44	1.6	1.76	V	Set LDO_LEVEL(LDO_CTL[3:2]) = 0x1				
		1.08	1.2	1.32	V	Set LDO_LEVEL(LDO_CTL[3:2]) = 0x0				
	C _{LDO}	1	-	1	μF	Connect to LDO_CAP pin				
Analog Operating Voltage	AV _{DD}	-	V _{DD}	-	V					
Battery Operating Voltage	V _{BAT}	-	V _{DD}	-	V					
Operating Current Normal Run Mode HCLK =36 MHz while(1){}executed from flash V _{LDO} =1.8 V	I _{DD1}	-	14	-	mA	V _{DD} 3.6 V	HXT 16 MHz	HIRC0 X	PLL V	All digital module V
	I _{DD2}	-	6.9	-	mA	3.6 V	16 MHz	X	V	X
	I _{DD3}	-	13.1	-	mA	2.2 V	16 MHz	X	V	V
	I _{DD4}	-	6.7	-	mA	2.2 V	16 MHz	X	V	X
Operating Current Normal Run Mode HCLK =36 MHz while(1){}executed from flash V _{LDO} =1.8 V	I _{DD5}	-	13.7	-	mA	3.6 V	12 MHz	X	V	V
	I _{DD6}	-	6.7	-	mA	3.6 V	12 MHz	X	V	X
	I _{DD7}	-	12.9	-	mA	2.2 V	12 MHz	X	V	V
	I _{DD8}	-	6.6	-	mA	2.2 V	12 MHz	X	V	X
Operating Current Normal Run Mode HCLK =36 MHz while(1){}executed from flash V _{LDO} =1.8 V	I _{DD10}	-	13.6	-	mA	3.6 V	4 MHz	X	V	V
	I _{DD11}	-	6.4	-	mA	3.6 V	4 MHz	X	V	X
	I _{DD12}	-	12.8	-	mA	2.2 V	4 MHz	X	V	V
	I _{DD13}	-	6.3	-	mA	2.2 V	4 MHz	X	V	X
Operating Current Normal Run Mode HCLK =36 MHz while(1){}executed from flash	I _{DD14}	-	13.6	-	mA	V _{DD} 3.6 V	HXT X	HIRC1 36 MHz	PLL X	All digital module V
		-	6.7	-	mA	3.6 V	X	36 MHz	X	X

PARAMETER	SYM.	SPECIFICATIONS				TEST CONDITIONS				
		MIN.	TYP.	MAX.	UNIT					
V _{LDO} =1.8 V	I _{DD16}	-	12.8	-	mA	2.2 V	X	36 MHz	X	V
	I _{DD17}	-	6.3	-	mA	2.2 V	X	36 MHz	X	X
Operating Current Normal Run Mode HCLK =36 MHz while(1){}executed from flash V _{LDO} =1.8 V	I _{DD18}	-	14.5	-	mA	V _{DD}	HXT	HIRC0	PLL	All digital module
						3.6 V	X	16 MHz	V	V
	I _{DD19}	-	6.7	-	mA	3.6 V	X	16 MHz	V	X
	I _{DD20}	-	13.6	-	mA	2.2 V	X	16 MHz	V	V
Operating Current Normal Run Mode HCLK =36 MHz while(1){}executed from flash V _{LDO} =1.8 V	I _{DD21}	-	6.5	-	mA	2.2 V	X	16 MHz	V	X
	I _{DD22}	-	14.5	-	mA	3.6 V	X	12 MHz	V	V
						3.6 V	X	12 MHz	V	X
	I _{DD24}	-	13.6	-	mA	2.2 V	X	12 MHz	V	V
I _{DD25}	-	6.6	-	mA	2.2 V	X	12 MHz	V	X	
Operating Current Normal Run Mode HCLK =36 MHz while(1){}executed from flash V _{LDO} =1.8 V	I _{DD26}	-	13.3	-	mA	V _{DD}	HXT	MIRC	PLL	All digital module
						3.6 V	X	4 MHz	V	V
	I _{DD27}	-	6.4	-	mA	3.6 V	X	4 MHz	V	X
	I _{DD28}	-	12.6	-	mA	2.2 V	X	4 MHz	V	V
Operating Current Normal Run Mode HCLK =18 MHz while(1){}executed from flash V _{LDO} =1.8 V	I _{DD29}	-	6.3	-	mA	2.2 V	X	4 MHz	V	X
						2.2 V	X	4 MHz	V	V
	I _{DD30}	-	7.3	-	mA	V _{DD}	HXT	HIRC0	PLL	All digital module
						3.6 V	18 MHz	X	X	V
I _{DD31}	-	3.8	-	mA	3.6 V	18 MHz	X	X	X	
I _{DD32}	-	7.1	-	mA	2.2 V	18 MHz	X	X	V	
Operating Current Normal Run Mode HCLK =18 MHz while(1){}executed from flash V _{LDO} =1.8 V	I _{DD33}	-	3.7	-	mA	2.2 V	18 MHz	X	X	X
						2.2 V	18 MHz	X	X	X
	I _{DD34}	-	7.5	-	mA	3.6 V	16 MHz	X	V	V
	I _{DD35}	-	3.9	-	mA	3.6 V	16 MHz	X	V	X
Operating Current Normal Run Mode HCLK =18 MHz while(1){}executed from flash V _{LDO} =1.8 V	I _{DD36}	-	7.3	-	mA	2.2 V	16 MHz	X	V	V
						2.2 V	16 MHz	X	V	X
	I _{DD37}	-	3.8	-	mA	2.2 V	16 MHz	X	V	X
	I _{DD38}	-	7.3	-	mA	3.6 V	12 MHz	X	V	V
Operating Current Normal Run Mode HCLK =18 MHz while(1){}executed from flash V _{LDO} =1.8 V	I _{DD39}	-	3.7	-	mA	3.6 V	12 MHz	X	V	X
						3.6 V	12 MHz	X	V	V
	I _{DD40}	-	7.1	-	mA	2.2 V	12 MHz	X	V	V
	I _{DD41}	-	3.7	-	mA	2.2 V	12 MHz	X	V	X
Operating Current Normal Run Mode HCLK =18 MHz while(1){}executed from	I _{DD42}	-	7.1	-	mA	3.6 V	4 MHz	X	V	V
	I _{DD43}	-	3.5	-	mA	3.6 V	4 MHz	X	V	X
	I _{DD44}	-	6.9	-	mA	2.2 V	4 MHz	X	V	V

PARAMETER	SYM.	SPECIFICATIONS				TEST CONDITIONS				
		MIN.	TYP.	MAX.	UNIT					
flash V _{LDO} =1.8 V	I _{DD45}	-	3.5	-	mA	2.2 V	4 MHz	X	V	X
Operating Current Normal Run Mode HCLK =18 MHz while(1){}executed from flash V _{LDO} =1.8 V	I _{DD46}	-	7.9	-	mA	V _{DD}	HXT	HIRC0	PLL	All digital module
						3.6 V	X	16 MHz	V	V
	I _{DD47}	-	3.7	-	mA	3.6 V	X	16 MHz	V	X
	I _{DD48}	-	7.7	-	mA	2.2 V	X	16 MHz	V	V
Operating Current Normal Run Mode HCLK =18 MHz while(1){}executed from flash V _{LDO1} =1.8 V	I _{DD49}	-	3.7	-	mA	2.2 V	X	16 MHz	V	X
	I _{DD50}	-	7.7	-	mA	3.6 V	X	12 MHz	V	V
	I _{DD51}	-	3.7	-	mA	3.6 V	X	12 MHz	V	X
	I _{DD52}	-	7.5	-	mA	2.2 V	X	12 MHz	V	V
Operating Current Normal Run Mode HCLK =18 MHz while(1){}executed from flash V _{LDO} =1.8 V	I _{DD53}	-	3.6	-	mA	2.2 V	X	12 MHz	V	X
	I _{DD54}	-	6.9	-	mA	V _{DD}	HXT	MIRC	PLL	All digital module
						3.6 V	X	4 MHz	V	V
	I _{DD55}	-	3.4	-	mA	3.6 V	X	4 MHz	V	X
I _{DD56}	-	6.8	-	mA	2.2 V	X	4 MHz	V	V	
Operating Current Normal Run Mode HCLK =16 MHz while(1){}executed from flash V _{LDO} =1.8 V	I _{DD57}	-	3.4	-	mA	2.2 V	X	4 MHz	V	X
	I _{DD58}	-	6.5	-	mA	V _{DD}	HXT	HIRC0	PLL	All digital module
						3.6 V	16 MHz	X	X	V
	I _{DD59}	-	3.3	-	mA	3.6 V	16 MHz	X	X	X
I _{DD60}	-	6.3	-	mA	2.2 V	16 MHz	X	X	V	
Operating Current Normal Run Mode HCLK =16 MHz while(1){}executed from flash V _{LDO1} =1.8 V	I _{DD61}	-	3.3	-	mA	2.2 V	16 MHz	X	X	X
	I _{DD62}	-	6.5	-	mA	3.6 V	12 MHz	X	V	V
	I _{DD63}	-	3.4	-	mA	3.6 V	12 MHz	X	V	X
	I _{DD64}	-	6.4	-	mA	2.2 V	12 MHz	X	V	V
Operating Current Normal Run Mode HCLK =16 MHz while(1){}executed from flash V _{LDO1} =1.8 V	I _{DD65}	-	3.4	-	mA	2.2 V	12 MHz	X	V	X
	I _{DD66}	-	6.3	-	mA	3.6 V	4 MHz	X	V	V
	I _{DD67}	-	3.1	-	mA	3.6 V	4 MHz	X	V	X
	I _{DD68}	-	6.3	-	mA	2.2 V	4 MHz	X	V	V
Operating Current Normal Run Mode HCLK =16 MHz while(1){}executed from flash V _{LDO1} =1.8 V	I _{DD69}	-	3.1	-	mA	2.2 V	4 MHz	X	V	X
	I _{DD70}	-	6.8	-	mA	V _{DD}	HXT	HIRC0	PLL	All digital module
						3.6 V	X	16 MHz	X	V
	I _{DD71}	-	3.1	-	mA	3.6 V	X	16 MHz	X	X
I _{DD72}	-	6.7	-	mA	2.2 V	X	16 MHz	X	V	

PARAMETER	SYM.	SPECIFICATIONS				TEST CONDITIONS				
		MIN.	TYP.	MAX.	UNIT					
	I _{DD73}	-	3.1	-	mA	2.2 V	X	16 MHz	X	X
Operating Current Normal Run Mode HCLK =16 MHz while(1){}executed from flash V _{LDO1} =1.8 V	I _{DD74}	-	7	-	mA	3.6 V	X	12 MHz	V	V
	I _{DD75}	-	3.3	-	mA	3.6 V	X	12 MHz	V	X
	I _{DD76}	-	6.8	-	mA	2.2 V	X	12 MHz	V	V
	I _{DD77}	-	3.2	-	mA	2.2 V	X	12 MHz	V	X
Operating Current Normal Run Mode HCLK =16 MHz while(1){}executed from flash V _{LDO} =1.8 V	I _{DD78}	-	6.2	-	mA	V _{DD}	HXT	MIRC	PLL	All digital module
						3.6 V	X	4 MHz	V	V
	I _{DD79}	-	3.1	-	mA	3.6 V	X	4 MHz	V	X
	I _{DD80}	-	6.1	-	mA	2.2 V	X	4 MHz	V	V
Operating Current Normal Run Mode HCLK =16 MHz while(1){}executed from flash V _{LDO} =1.8 V	I _{DD81}	-	3.1	-	mA	2.2 V	X	4 MHz	V	X
	I _{DD82}	-	4.9	-	mA	V _{DD}	HXT	HIRC0	PLL	All digital module
						3.6 V	12 MHz	X	X	V
	I _{DD83}	-	2.5	-	mA	3.6 V	12 MHz	X	X	X
I _{DD84}	-	4.8	-	mA	2.2 V	12 MHz	X	X	V	
Operating Current Normal Run Mode HCLK =12 MHz while(1){}executed from flash V _{LDO} =1.8 V	I _{DD85}	-	2.5	-	mA	2.2 V	12 MHz	X	X	X
	I _{DD86}	-	4.9	-	mA	3.6 V	4 MHz	X	V	V
	I _{DD87}	-	2.5	-	mA	3.6 V	4 MHz	X	V	X
	I _{DD88}	-	4.8	-	mA	2.2 V	4 MHz	X	V	V
Operating Current Normal Run Mode HCLK =12 MHz while(1){}executed from flash V _{LDO} =1.8 V	I _{DD89}	-	2.5	-	mA	2.2 V	4 MHz	X	V	X
	I _{DD90}	-	5.3	-	mA	V _{DD}	HXT	HIRC0	PLL	All digital module
						3.6 V	X	12 MHz	X	V
	I _{DD91}	-	2.5	-	mA	3.6 V	X	12 MHz	X	X
I _{DD92}	-	5.2	-	mA	2.2 V	X	12 MHz	X	V	
Operating Current Normal Run Mode HCLK =12 MHz while(1){}executed from flash V _{LDO} =1.8 V	I _{DD93}	-	2.5	-	mA	2.2 V	X	12 MHz	X	X
	I _{DD94}	-	4.8	-	mA	V _{DD}	HXT	MIRC	PLL	All digital module
						3.6 V	X	4 MHz	V	V
	I _{DD95}	-	2.4	-	mA	3.6 V	X	4 MHz	V	X
I _{DD96}	-	4.7	-	mA	2.2 V	X	4 MHz	V	V	
Operating Current Normal Run Mode HCLK =4 MHz while(1){}executed from flash	I _{DD97}	-	2.4	-	mA	2.2 V	X	4 MHz	V	X
	I _{DD98}	-	1.1	-	mA	V _{DD}	HXT	MIRC	PLL	All digital module
						3.6 V	4 MHz	X	X	V
I _{DD99}	-	0.7	-	mA	3.6 V	4 MHz	X	X	X	

PARAMETER	SYM.	SPECIFICATIONS				TEST CONDITIONS				
		MIN.	TYP.	MAX.	UNIT					
V _{LDO} =1.8 V	I _{DD100}	-	1.1	-	mA	2.2 V	4 MHz	X	X	V
	I _{DD101}	-	0.7	-	mA	2.2 V	4 MHz	X	X	X
Operating Current Normal Run Mode HCLK =4 MHz while(1){}executed from flash V _{LDO} =1.8 V	I _{DD102}	-	1.7	-	mA	3.6 V	X	4 MHz	X	V
	I _{DD103}	-	1	-	mA	3.6 V	X	4 MHz	X	X
	I _{DD104}	-	1.7	-	mA	2.2 V	X	4 MHz	X	V
	I _{DD105}	-	0.9	-	mA	2.2 V	X	4 MHz	X	X
Operating Current Normal Run Mode HCLK =32.768 kHz while(1){}executed from flash V _{LDO} =1.8 V	I _{DD106}	-	148	-	μA	V _{DD}	LXT	LIRC	PLL	All digital module
						3.6 V	32.768 kHz	X	X	V
	I _{DD107}	-	130	-	μA	3.6 V	32.768 kHz	X	X	X
	I _{DD108}	-	126	-	μA	2.2 V	32.768 kHz	X	X	V
Operating Current Normal Run Mode HCLK =10 kHz while(1){}executed from flash V _{LDO} =1.8 V	I _{DD109}	-	120	-	μA	2.2 V	32.768 kHz	X	X	X
	I _{DD110}	-	128	-	μA	3.6 V	X	10 kHz	X	V
	I _{DD111}	-	126	-	μA	3.6 V	X	10 kHz	X	X
	I _{DD112}	-	118	-	μA	2.2 V	X	10 kHz	X	V
Operating Current Normal Run Mode HCLK =18 MHz while(1){}executed from flash V _{LDO} =1.6 V	I _{DD113}	-	116	-	μA	2.2 V	X	10 kHz	X	X
	I _{DD114}	-	6.5	-	mA	V _{DD}	HXT	HIRC0	PLL	All digital module
						3.6 V	18 MHz	X	X	V
	I _{DD115}	-	3.4	-	mA	3.6 V	18 MHz	X	X	X
I _{DD116}	-	6.4	-	mA	2.2 V	18 MHz	X	X	V	
Operating Current Normal Run Mode HCLK =18 MHz while(1){}executed from flash V _{LDO} =1.6 V	I _{DD117}	-	3.3	-	mA	2.2 V	18 MHz	X	X	X
	I _{DD118}	-	6.6	-	mA	3.6 V	16 MHz	X	V	V
	I _{DD119}	-	3.5	-	mA	3.6 V	16 MHz	X	V	X
	I _{DD120}	-	6.6	-	mA	2.2 V	16 MHz	X	V	V
Operating Current Normal Run Mode HCLK =18 MHz while(1){}executed from flash V _{LDO} =1.6 V	I _{DD121}	-	3.4	-	mA	2.2 V	16 MHz	X	V	X
	I _{DD122}	-	6.5	-	mA	3.6 V	12 MHz	X	V	V
	I _{DD123}	-	3.3	-	mA	3.6 V	12 MHz	X	V	X
	I _{DD124}	-	6.4	-	mA	2.2 V	12 MHz	X	V	V
Operating Current Normal Run Mode HCLK =18 MHz while(1){}executed from flash V _{LDO} =1.6 V	I _{DD125}	-	3.3	-	mA	2.2 V	12 MHz	X	V	X
	I _{DD126}	-	6.2	-	mA	3.6 V	4 MHz	X	V	V
	I _{DD127}	-	3.1	-	mA	3.6 V	4 MHz	X	V	X
	I _{DD128}	-	6.2	-	mA	2.2 V	4 MHz	X	V	V
Operating Current Normal Run Mode HCLK =18 MHz while(1){}executed from flash V _{LDO} =1.6 V	I _{DD129}	-	3.1	-	mA	2.2 V	4 MHz	X	V	X

PARAMETER	SYM.	SPECIFICATIONS				TEST CONDITIONS				
		MIN.	TYP.	MAX.	UNIT					
Operating Current Normal Run Mode HCLK =18 MHz while(1){}executed from flash V _{LDO} =1.6 V	I _{DD130}	-	7	-	mA	V _{DD}	HXT	HIRC0	PLL	All digital module
		3.6 V	X	16 MHz		V	V			
	I _{DD131}	-	3.3	-	mA	3.6 V	X	16 MHz	V	X
	I _{DD132}	-	7	-		2.2 V	X	16 MHz	V	V
I _{DD133}	-	3.3	-	mA	2.2 V	X	16 MHz	V	X	
I _{DD134}	-	6.9	-		3.6 V	X	12 MHz	V	V	
Operating Current Normal Run Mode HCLK =18 MHz while(1){}executed from flash V _{LDO1} =1.6 V	I _{DD135}	-	3.3	-	mA	3.6 V	X	12 MHz	V	X
	I _{DD136}	-	6.8	-		2.2 V	X	12 MHz	V	V
	I _{DD137}	-	3.3	-	mA	2.2 V	X	12 MHz	V	X
	I _{DD138}	-	6.2	-		V _{DD}	HXT	MIRC	PLL	All digital module
Operating Current Normal Run Mode HCLK =18 MHz while(1){}executed from flash V _{LDO} =1.6 V	I _{DD139}	-	3.1	-	mA	3.6 V	X	4 MHz	V	X
		I _{DD140}	-	6.1		-	2.2 V	X	4 MHz	V
	I _{DD141}	-	3	-	mA	2.2 V	X	4 MHz	V	X
	I _{DD142}	-	5.7	-		V _{DD}	HXT	HIRC0	PLL	All digital module
Operating Current Normal Run Mode HCLK =16 MHz while(1){}executed from flash V _{LDO} =1.6 V	I _{DD143}	-	2.9	-	mA	3.6 V	16 MHz	X	X	V
		I _{DD144}	-	5.7		-	2.2 V	16 MHz	X	X
	I _{DD145}	-	2.9	-	mA	2.2 V	16 MHz	X	X	X
	I _{DD146}	-	5.8	-		3.6 V	12 MHz	X	V	V
Operating Current Normal Run Mode HCLK =16 MHz while(1){}executed from flash V _{LDO1} =1.6 V	I _{DD147}	-	3	-	mA	3.6 V	12 MHz	X	V	X
	I _{DD148}	-	5.7	-		2.2 V	12 MHz	X	V	V
	I _{DD149}	-	3	-	mA	2.2 V	12 MHz	X	V	X
	I _{DD150}	-	5.6	-		mA	3.6 V	4 MHz	X	V
Operating Current Normal Run Mode HCLK =16 MHz while(1){}executed from flash V _{LDO1} =1.6 V	I _{DD151}	-	2.8	-	mA		3.6 V	4 MHz	X	V
	I _{DD152}	-	5.6	-		2.2 V	4 MHz	X	V	V
	I _{DD153}	-	2.8	-	mA	2.2 V	4 MHz	X	V	X
	I _{DD154}	-	6	-		V _{DD}	HXT	HIRC0	PLL	All digital module
Operating Current Normal Run Mode HCLK =16 MHz while(1){}executed from flash V _{LDO} =1.6 V	I _{DD155}	-	2.8	-	mA	3.6 V	X	16 MHz	X	V
		I _{DD156}	-	5.9		-	2.2 V	X	16 MHz	X
	I _{DD157}	-	2.8	-	mA	2.2 V	X	16 MHz	X	X
	I _{DD158}	-	5.9	-		3.6 V	X	16 MHz	X	V

PARAMETER	SYM.	SPECIFICATIONS				TEST CONDITIONS				
		MIN.	TYP.	MAX.	UNIT					
Operating Current Normal Run Mode HCLK =16 MHz while(1){}executed from flash V _{LDO1} =1.6 V	I _{DD158}	-	6.2	-	mA	3.6 V	X	12 MHz	V	V
	I _{DD159}	-	3	-	mA	3.6 V	X	12 MHz	V	X
	I _{DD160}	-	6.2	-	mA	2.2 V	X	12 MHz	V	V
	I _{DD161}	-	3	-	mA	2.2 V	X	12 MHz	V	X
Operating Current Normal Run Mode HCLK =16 MHz while(1){}executed from flash V _{LDO} =1.6 V	I _{DD162}	-	5.5	-	mA	V _{DD}	HXT	MIRC	PLL	All digital module
						3.6 V	X	4 MHz	V	V
	I _{DD163}	-	2.8	-	mA	3.6 V	X	4 MHz	V	X
	I _{DD164}	-	5.5	-	mA	2.2 V	X	4 MHz	V	V
Operating Current Normal Run Mode HCLK =12 MHz while(1){}executed from flash V _{LDO} =1.6 V	I _{DD166}	-	4.3	-	mA	V _{DD}	HXT	HIRC0	PLL	All digital module
						3.6 V	12 MHz	X	X	V
	I _{DD167}	-	2.2	-	mA	3.6 V	12 MHz	X	X	X
	I _{DD168}	-	4.3	-	mA	2.2 V	12 MHz	X	X	V
Operating Current Normal Run Mode HCLK =12 MHz while(1){}executed from flash V _{LDO} =1.6 V	I _{DD169}	-	2.2	-	mA	2.2 V	12 MHz	X	X	X
Operating Current Normal Run Mode HCLK =12 MHz while(1){}executed from flash V _{LDO} =1.6 V	I _{DD170}	-	4.3	-	mA	3.6 V	4 MHz	X	V	V
	I _{DD171}	-	2.3	-	mA	3.6 V	4 MHz	X	V	X
	I _{DD172}	-	4.3	-	mA	2.2 V	4 MHz	X	V	V
	I _{DD173}	-	2.3	-	mA	2.2 V	4 MHz	X	V	X
Operating Current Normal Run Mode HCLK =12 MHz while(1){}executed from flash V _{LDO} =1.6 V	I _{DD174}	-	4.7	-	mA	V _{DD}	HXT	HIRC0	PLL	All digital module
						3.6 V	X	12 MHz	X	V
	I _{DD175}	-	2.2	-	mA	3.6 V	X	12 MHz	X	X
	I _{DD176}	-	4.7	-	mA	2.2 V	X	12 MHz	X	V
Operating Current Normal Run Mode HCLK =12 MHz while(1){}executed from flash V _{LDO} =1.6 V	I _{DD177}	-	2.2	-	mA	2.2 V	X	12 MHz	X	X
Operating Current Normal Run Mode HCLK =12 MHz while(1){}executed from flash V _{LDO} =1.6 V	I _{DD178}	-	4.3	-	mA	V _{DD}	HXT	MIRC	PLL	All digital module
						3.6 V	X	4 MHz	V	V
	I _{DD179}	-	2.2	-	mA	3.6 V	X	4 MHz	V	X
	I _{DD180}	-	4.2	-	mA	2.2 V	X	4 MHz	V	V
Operating Current Normal Run Mode HCLK =4 MHz while(1){}executed from flash V _{LDO} =1.6 V	I _{DD181}	-	2.2	-	mA	2.2 V	X	4 MHz	V	X
Operating Current Normal Run Mode HCLK =4 MHz while(1){}executed from flash V _{LDO} =1.6 V	I _{DD182}	-	1	-	mA	V _{DD}	HXT	HIRC0	PLL	All digital module
						3.6 V	4 MHz	X	X	V
	I _{DD183}	-	0.6	-	mA	3.6 V	4 MHz	X	X	X
I _{DD184}	-	1	-	mA	2.2 V	4 MHz	X	X	V	

PARAMETER	SYM.	SPECIFICATIONS				TEST CONDITIONS				
		MIN.	TYP.	MAX.	UNIT					
	I _{DD185}	-	0.6	-	mA	2.2 V	4 MHz	X	X	X
Operating Current Normal Run Mode HCLK =4 MHz while(1){}executed from flash V _{LDO} =1.6 V	I _{DD186}	-	1.6	-	mA	V _{DD}	HXT	MIRC	PLL	All digital module
						3.6 V	X	4 MHz	X	V
	I _{DD187}	-	0.9	-	mA	3.6 V	X	4 MHz	X	X
	I _{DD188}	-	1.5	-	mA	2.2 V	X	4 MHz	X	V
	I _{DD189}	-	0.9	-	mA	2.2 V	X	4 MHz	X	X
Operating Current Normal Run Mode HCLK =32.768 kHz while(1){}executed from flash V _{LDO} =1.6 V	I _{DD190}	-	147	-	μA	V _{DD}	LXT	LIRC	PLL	All digital module
						3.6 V	32.768 kHz	X	X	V
	I _{DD191}	-	141	-	μA	3.6 V	32.768 kHz	X	X	X
	I _{DD192}	-	124	-	μA	2.2 V	32.768 kHz	X	X	V
	I _{DD193}	-	119	-	μA	2.2 V	32.768 kHz	X	X	X
Operating Current Normal Run Mode HCLK =10 kHz while(1){}executed from flash V _{LDO} =1.6 V	I _{DD194}	-	139	-	μA	3.6 V	X	10 kHz	X	V
	I _{DD195}	-	137	-	μA	3.6 V	X	10 kHz	X	X
	I _{DD196}	-	117	-	μA	2.2 V	X	10 kHz	X	V
	I _{DD197}	-	115	-	μA	2.2 V	X	10 kHz	X	X
Operating Current Normal Run Mode HCLK =2 MHz while(1){}executed from flash V _{LDO} =1.2 V	I _{DD198}	-	0.9	-	mA	V _{DD}	HXT	MIRC	PLL	All digital module
						3.6 V	4 MHz	X	X	V
	I _{DD199}	-	0.6	-	mA	3.6 V	4 MHz	X	X	X
	I _{DD200}	-	0.9	-	mA	2.2 V	4 MHz	X	X	V
Operating Current Normal Run Mode HCLK =2 MHz while(1){}executed from flash V _{LDO} =1.2 V	I _{DD201}	-	0.8	-	mA	V _{DD}	HXT	MIRC	PLL	All digital module
						3.6 V	X	4 MHz	X	V
	I _{DD202}	-	0.5	-	mA	3.6 V	X	4 MHz	X	X
	I _{DD203}	-	0.8	-	mA	2.2 V	X	4 MHz	X	V
Operating Current Normal Run Mode HCLK =32 kHz while(1){}executed from flash V _{LDO} =1.2 V	I _{DD205}	-	218	-	μA	V _{DD}	LXT	LIRC	PLL	All digital module
						3.6 V	32.768 kHz	X	X	V
	I _{DD206}	-	225	-	μA	3.6 V	32.768 kHz	X	X	X
	I _{DD207}	-	206	-	μA	2.2 V	32.768 kHz	X	X	V
Operating Current Normal Run Mode HCLK =10 kHz	I _{DD209}	-	122	-	μA	V _{DD}	LXT	MIRC	PLL	All digital module
						3.6 V	X	10 kHz	X	V

PARAMETER	SYM.	SPECIFICATIONS				TEST CONDITIONS				
		MIN.	TYP.	MAX.	UNIT					
while(1){executed from flash V _{LDO} =1.2 V	I _{DD210}	-	121	-	μA	3.6 V	X	10 kHz	X	X
	I _{DD211}	-	112	-	μA	2.2 V	X	10 kHz	X	V
	I _{DD212}	-	111	-	μA	2.2 V	X	10 kHz	X	X
Operating Current Idle Mode HCLK =36 MHz V _{LDO} =1.8 V	I _{IDLE1}	-	9.5	-	mA	V _{DD}	HXT	HIRC0	PLL	All digital module
						3.6 V	16 MHz	X	V	V
	I _{IDLE2}	-	2.4	-	mA	3.6 V	16 MHz	X	V	X
	I _{IDLE3}	-	9.1	-	mA	2.2 V	16 MHz	X	V	V
Operating Current Idle Mode HCLK =36 MHz V _{LDO} =1.8 V	I _{IDLE4}	-	2.4	-	mA	2.2 V	16 MHz	X	V	X
	I _{IDLE5}	-	9.3	-	mA	3.6 V	12 MHz	X	V	V
	I _{IDLE6}	-	2.2	-	mA	3.6 V	12 MHz	X	V	X
	I _{IDLE7}	-	9	-	mA	2.2 V	12 MHz	X	V	V
Operating Current Idle Mode HCLK =36 MHz V _{LDO} =1.8 V	I _{IDLE8}	-	2.2	-	mA	2.2 V	12 MHz	X	V	X
	I _{IDLE9}	-	9.1	-	mA	3.6 V	4 MHz	X	V	V
	I _{IDLE10}	-	2	-	mA	3.6 V	4 MHz	X	V	X
	I _{IDLE11}	-	8.8	-	mA	2.2 V	4 MHz	X	V	V
Operating Current Idle Mode HCLK =36 MHz V _{LDO} =1.8 V	I _{IDLE12}	-	2	-	mA	2.2 V	4 MHz	X	V	X
						3.6 V	4 MHz	X	V	V
	I _{IDLE13}	-	9	-	mA	V _{DD}	HXT	HIRC1	PLL	All digital module
	I _{IDLE14}	-	1.9	-	mA	3.6 V	X	36 MHz	X	X
Operating Current Idle Mode HCLK =36 MHz V _{LDO} =1.8 V	I _{IDLE15}	-	8.8	-	mA	2.2 V	X	36 MHz	X	V
	I _{IDLE16}	-	1.9	-	mA	2.2 V	X	36 MHz	X	X
	I _{IDLE17}	-	10.1	-	mA	V _{DD}	HXT	HIRC0	PLL	All digital module
						3.6 V	X	16 MHz	V	V
Operating Current Idle Mode HCLK =36 MHz V _{LDO} =1.8 V	I _{IDLE18}	-	2.3	-	mA	3.6 V	X	16 MHz	V	X
	I _{IDLE19}	-	9.7	-	mA	2.2 V	X	16 MHz	V	V
	I _{IDLE20}	-	2.2	-	mA	2.2 V	X	16 MHz	V	X
	Operating Current Idle Mode HCLK =36 MHz V _{LDO} =1.8 V	I _{IDLE21}	-	10	-	mA	3.6 V	X	12 MHz	V
I _{IDLE22}		-	2.2	-	mA	3.6 V	X	12 MHz	V	X
I _{IDLE23}		-	9.6	-	mA	2.2 V	X	12 MHz	V	V
I _{IDLE24}		-	2.2	-	mA	2.2 V	X	12 MHz	V	X
Operating Current Idle Mode HCLK =36 MHz	I _{IDLE25}	-	9	-	mA	V _{DD}	HXT	MIRC	PLL	All digital module
						3.6 V	X	4 MHz	V	V

PARAMETER	SYM.	SPECIFICATIONS				TEST CONDITIONS				
		MIN.	TYP.	MAX.	UNIT					
V _{LDO} =1.8 V	I _{IDLE26}	-	6.3	-	mA	3.6 V	X	4 MHz	V	X
	I _{IDLE27}	-	8.7	-	mA	2.2 V	X	4 MHz	V	V
	I _{IDLE28}	-	6.2	-	mA	2.2 V	X	4 MHz	V	X
Operating Current Idle Mode HCLK =18 MHz V _{LDO} =1.8 V	I _{IDLE29}	-	5	-	mA	V _{DD}	HXT	HIRCO	PLL	All digital module
						3.6 V	18 MHz	X	X	V
	I _{IDLE30}	-	1.5	-	mA	3.6 V	18 MHz	X	X	X
	I _{IDLE31}	-	5	-	mA	2.2 V	18 MHz	X	X	V
	I _{IDLE32}	-	1.5	-	mA	2.2 V	18 MHz	X	X	X
Operating Current Idle Mode HCLK =18 MHz V _{LDO} =1.8 V	I _{IDLE33}	-	5.2	-	mA	3.6 V	16 MHz	X	V	V
	I _{IDLE34}	-	1.7	-	mA	3.6 V	16 MHz	X	V	X
	I _{IDLE35}	-	5.1	-	mA	2.2 V	16 MHz	X	V	V
	I _{IDLE36}	-	1.6	-	mA	2.2 V	16 MHz	X	V	X
Operating Current Idle Mode HCLK =18 MHz V _{LDO} =1.8 V	I _{IDLE37}	-	5.1	-	mA	3.6 V	12 MHz	X	V	V
	I _{IDLE38}	-	1.5	-	mA	3.6 V	12 MHz	X	V	X
	I _{IDLE39}	-	5.	-	mA	2.2 V	12 MHz	X	V	V
	I _{IDLE40}	-	1.5	-	mA	2.2 V	12 MHz	X	V	X
Operating Current Idle Mode HCLK =18 MHz V _{LDO} =1.8 V	I _{IDLE41}	-	4.8	-	mA	3.6 V	4 MHz	X	V	V
	I _{IDLE42}	-	1.3	-	mA	3.6 V	4 MHz	X	V	X
	I _{IDLE43}	-	4.8	-	mA	2.2 V	4 MHz	X	V	V
	I _{IDLE44}	-	1.2	-	mA	2.2 V	4 MHz	X	V	X
Operating Current Idle Mode HCLK =18 MHz V _{LDO} =1.8 V	I _{IDLE45}	-	5.6	-	mA	V _{DD}	HXT	HIRCO	PLL	All digital module
						3.6 V	X	16 MHz	V	V
	I _{IDLE46}	-	1.5	-	mA	3.6 V	X	16 MHz	V	X
	I _{IDLE47}	-	5.6	-	mA	2.2 V	X	16 MHz	V	V
Operating Current Idle Mode HCLK =18 MHz V _{LDO} =1.8 V	I _{IDLE48}	-	1.5	-	mA	2.2 V	X	16 MHz	V	X
	I _{IDLE49}	-	5.5	-	mA	3.6 V	X	12 MHz	V	V
	I _{IDLE50}	-	3.7	-	mA	3.6 V	X	12 MHz	V	X
	I _{IDLE51}	-	5.4	-	mA	2.2 V	X	12 MHz	V	V
Operating Current Idle Mode HCLK =18 MHz V _{LDO} =1.8 V	I _{IDLE52}	-	3.6	-	mA	2.2 V	X	12 MHz	V	X
	I _{IDLE53}	-	4.7	-	mA	V _{DD}	HXT	MIRC	PLL	All digital module
						3.6 V	X	4 MHz	V	V
I _{IDLE54}	-	1.2	-	mA	3.6 V	X	4 MHz	V	X	

PARAMETER	SYM.	SPECIFICATIONS				TEST CONDITIONS				
		MIN.	TYP.	MAX.	UNIT					
	I _{IDLE55}	-	4.7	-	mA	2.2 V	X	4 MHz	V	V
	I _{IDLE56}	-	1.2	-	mA	2.2 V	X	4 MHz	V	X
Operating Current Idle Mode HCLK =16 MHz V _{LDO} =1.8 V	I _{IDLE57}	-	4.5	-	mA	V _{DD}	HXT	HIRC0	PLL	All digital module
						3.6 V	16 MHz	X	X	V
	I _{IDLE58}	-	1.3	-	mA	3.6 V	16 MHz	X	X	X
	I _{IDLE59}	-	4.4	-	mA	2.2 V	16 MHz	X	X	V
	I _{IDLE60}	-	1.3	-	mA	2.2 V	16 MHz	X	X	X
Operating Current Idle Mode HCLK =16 MHz V _{LDO} =1.8 V	I _{IDLE61}	-	4.6	-	mA	3.6 V	12 MHz	X	V	V
	I _{IDLE62}	-	1.4	-	mA	3.6 V	12 MHz	X	V	X
	I _{IDLE63}	-	4.5	-	mA	2.2 V	12 MHz	X	V	V
	I _{IDLE64}	-	1.4	-	mA	2.2 V	12 MHz	X	V	X
Operating Current Idle Mode HCLK =16 MHz V _{LDO} =1.8 V	I _{IDLE65}	-	4.3	-	mA	3.6 V	4 MHz	X	V	V
	I _{IDLE66}	-	1.2	-	mA	3.6 V	4 MHz	X	V	X
	I _{IDLE67}	-	4.3	-	mA	2.2 V	4 MHz	X	V	V
	I _{IDLE68}	-	1.2	-	mA	2.2 V	4 MHz	X	V	X
Operating Current Idle Mode HCLK =16 MHz V _{LDO} =1.8 V	I _{IDLE69}	-	4.9	-	mA	V _{DD}	HXT	HIRC0	PLL	All digital module
						3.6 V	X	16 MHz	X	V
	I _{IDLE70}	-	1.2	-	mA	3.6 V	X	16 MHz	X	X
	I _{IDLE71}	-	4.8	-	mA	2.2 V	X	16 MHz	X	V
Operating Current Idle Mode HCLK =16 MHz V _{LDO} =1.8 V	I _{IDLE72}	-	1.2	-	mA	2.2 V	X	16 MHz	X	X
	I _{IDLE73}	-	5	-	mA	3.6 V	X	12 MHz	V	V
	I _{IDLE74}	-	1.4	-	mA	3.6 V	X	12 MHz	V	X
	I _{IDLE75}	-	5	-	mA	2.2 V	X	12 MHz	V	V
Operating Current Idle Mode HCLK =16 MHz V _{LDO} =1.8 V	I _{IDLE76}	-	1.4	-	mA	2.2 V	X	12 MHz	V	X
	I _{IDLE77}	-	4.3	-	mA	V _{DD}	HXT	MIRC	PLL	All digital module
						3.6 V	X	4 MHz	V	V
	I _{IDLE78}	-	1.1	-	mA	3.6 V	X	4 MHz	V	X
I _{IDLE79}	-	4.2	-	mA	2.2 V	X	4 MHz	V	V	
Operating Current Idle Mode HCLK =12 MHz V _{LDO} =1.8 V	I _{IDLE80}	-	1.1	-	mA	2.2 V	X	4 MHz	V	X
	I _{IDLE81}	-	3.4	-	mA	V _{DD}	HXT	HIRC0	PLL	All digital module
3.6 V						12 MHz	X	X	V	
I _{IDLE82}	-	1	-	mA	3.6 V	12 MHz	X	X	X	

PARAMETER	SYM.	SPECIFICATIONS				TEST CONDITIONS				
		MIN.	TYP.	MAX.	UNIT					
	I _{IDLE83}	-	3.3	-	mA	2.2 V	12 MHz	X	X	V
	I _{IDLE84}	-	1	-	mA	2.2 V	12 MHz	X	X	X
Operating Current Idle Mode HCLK =12 MHz V _{LDO} =1.8 V	I _{IDLE85}	-	3.4	-	mA	3.6 V	4 MHz	X	V	V
	I _{IDLE86}	-	1	-	mA	3.6 V	4 MHz	X	V	X
	I _{IDLE87}	-	3.3	-	mA	2.2 V	4 MHz	X	V	V
	I _{IDLE88}	-	1	-	mA	2.2 V	4 MHz	X	V	X
Operating Current Idle Mode HCLK =12 MHz V _{LDO} =1.8 V	I _{IDLE89}	-	3.8	-	mA	V _{DD}	HXT	HIRC0	PLL	All digital module
						3.6 V	X	12 MHz	X	V
	I _{IDLE90}	-	1	-	mA	3.6 V	X	12 MHz	X	X
	I _{IDLE91}	-	3.7	-	mA	2.2 V	X	12 MHz	X	V
Operating Current Idle Mode HCLK =12 MHz V _{LDO} =1.8 V	I _{IDLE93}	-	3.3	-	mA	V _{DD}	HXT	MIRC	PLL	All digital module
						3.6 V	X	4 MHz	V	V
	I _{IDLE94}	-	1	-	mA	3.6 V	X	4 MHz	V	X
	I _{IDLE95}	-	3.3	-	mA	2.2 V	X	4 MHz	V	V
Operating Current Idle Mode HCLK =4 MHz V _{LDO} =1.8 V	I _{IDLE97}	-	0.9	-	mA	V _{DD}	HXT	MIRC	PLL	All digital module
						3.6 V	4 MHz	X	X	V
	I _{IDLE98}	-	0.5	-	mA	3.6 V	4 MHz	X	X	X
	I _{IDLE99}	-	0.9	-	mA	2.2 V	4 MHz	X	X	V
Operating Current Idle Mode HCLK =4 MHz V _{LDO} =1.8 V	I _{IDLE101}	-	1.2	-	mA	3.6 V	X	4 MHz	X	V
	I _{IDLE103}	-	1.2	-	mA	2.2 V	X	4 MHz	X	V
	I _{IDLE104}	-	0.4	-	mA	2.2 V	X	4 MHz	X	X
Operating Current Idle Mode HCLK =32.768 kHz V _{LDO} =1.8 V	I _{IDLE105}	-	132	-	μA	V _{DD}	LXT	LIRC	PLL	All digital module
						3.6 V	32.768 kHz	X	X	V
	I _{IDLE106}	-	126	-	μA	3.6 V	32.768 kHz	X	X	X
	I _{IDLE107}	-	122	-	μA	2.2 V	32.768 kHz	X	X	V
Operating Current Operating Current Idle Mode	I _{IDLE108}	-	116	-	μA	2.2 V	32.768 kHz	X	X	X
	I _{IDLE109}	-	127	-	μA	3.6 V	X	10 kHz	X	V
	I _{IDLE110}	-	125	-	μA	3.6 V	X	10 kHz	X	X

PARAMETER	SYM.	SPECIFICATIONS				TEST CONDITIONS				
		MIN.	TYP.	MAX.	UNIT					
HCLK =10 kHz V _{LDO} =1.8 V	I _{IDLE111}	-	116	-	μA	2.2 V	X	10 kHz	X	V
	I _{IDLE112}	-	114	-	μA	2.2 V	X	10 kHz	X	X
Operating Current Idle Mode HCLK =18 MHz V _{LDO} =1.6 V	I _{IDLE113}	-	4.5	-	mA	V _{DD}	HXT	HIRC0	PLL	All digital module
		3.6 V	18 MHz	X	X	V				
	I _{IDLE114}	-	1.3	-	mA	3.6 V	18 MHz	X	X	X
	I _{IDLE115}	-	4.4	-	mA	2.2 V	18 MHz	X	X	V
Operating Current Idle Mode HCLK =18 MHz V _{LDO} =1.6 V	I _{IDLE116}	-	1.3	-	mA	2.2 V	18 MHz	X	X	X
	I _{IDLE117}	-	4.6	-	mA	3.6 V	16 MHz	X	V	V
		I _{IDLE118}		1.5		mA	3.6 V	16 MHz	X	V
	I _{IDLE119}	-	4.6	-	mA	2.2 V	16 MHz	X	V	V
Operating Current Idle Mode HCLK =18 MHz V _{LDO} =1.6 V	I _{IDLE120}	-	1.4	-	mA	2.2 V	16 MHz	X	V	X
	I _{IDLE121}	-	4.5	-	mA	3.6 V	12 MHz	X	V	V
		I _{IDLE122}		1.4		mA	3.6 V	12 MHz	X	V
	I _{IDLE123}	-	4.4	-	mA	2.2 V	12 MHz	X	V	V
Operating Current Idle Mode HCLK =18 MHz V _{LDO} =1.6 V	I _{IDLE124}	-	1.3	-	mA	2.2 V	12 MHz	X	V	X
	I _{IDLE125}	-	4.3	-	mA	3.6 V	4 MHz	X	V	V
		I _{IDLE126}		1.1		mA	3.6 V	4 MHz	X	V
	I _{IDLE127}	-	4.2	-	mA	2.2 V	4 MHz	X	V	V
Operating Current Idle Mode HCLK =18 MHz V _{LDO} =1.6 V	I _{IDLE128}	-	1.1	-	mA	2.2 V	4 MHz	X	V	X
	I _{IDLE129}	-	5	-	mA	V _{DD}	HXT	HIRC0	PLL	All digital module
		3.6 V	X	16 MHz	V	V				
	I _{IDLE130}	-	1.4	-	mA	3.6 V	X	16 MHz	V	X
I _{IDLE131}	-	5	-	mA	2.2 V	X	16 MHz	V	V	
Operating Current Idle Mode HCLK =18 MHz V _{LDO} =1.6 V	I _{IDLE132}	-	1.3	-	mA	2.2 V	X	16 MHz	V	X
	I _{IDLE133}	-	4.9	-	mA	3.6 V	X	12 MHz	V	V
		I _{IDLE134}		3.3		mA	3.6 V	X	12 MHz	V
	I _{IDLE135}	-	4.8	-	mA	2.2 V	X	12 MHz	V	V
Operating Current Idle Mode HCLK =18 MHz V _{LDO} =1.6 V	I _{IDLE136}	-	3.3	-	mA	2.2 V	X	12 MHz	V	X
	I _{IDLE137}	-	4.2	-	mA	V _{DD}	HXT	MIRC	PLL	All digital module
		3.6 V	X	4 MHz	V	V				
	I _{IDLE138}	-	1.1	-	mA	3.6 V	X	4 MHz	V	X
I _{IDLE139}	-	4.2	-	mA	2.2 V	X	4 MHz	V	V	

PARAMETER	SYM.	SPECIFICATIONS				TEST CONDITIONS				
		MIN.	TYP.	MAX.	UNIT					
	I _{IDLE140}	-	1.1	-	mA	2.2 V	X	4 MHz	V	X
Operating Current Idle Mode HCLK =16 MHz V _{LDO} =1.6 V	I _{IDLE141}	-	3.9	-	mA	V _{DD}	HXT	HIRC0	PLL	All digital module
						3.6 V	16 MHz	X	X	V
	I _{IDLE142}	-	1.2	-	mA	3.6 V	16 MHz	X	X	X
	I _{IDLE143}	-	3.9	-	mA	2.2 V	16 MHz	X	X	V
	I _{IDLE144}	-	1.1	-	mA	2.2 V	16 MHz	X	X	X
Operating Current Idle Mode HCLK =16 MHz V _{LDO} =1.6 V	I _{IDLE145}	-	4.1	-	mA	3.6 V	12 MHz	X	V	V
	I _{IDLE146}	-	1.3	-	mA	3.6 V	12 MHz	X	V	X
	I _{IDLE147}	-	4	-	mA	2.2 V	12 MHz	X	V	V
	I _{IDLE148}	-	1.3	-	mA	2.2 V	12 MHz	X	V	X
Operating Current Idle Mode HCLK =16 MHz V _{LDO} =1.6 V	I _{IDLE149}	-	3.9	-	mA	3.6 V	4 MHz	X	V	V
	I _{IDLE150}	-	1.1	-	mA	3.6 V	4 MHz	X	V	X
	I _{IDLE151}	-	3.8	-	mA	2.2 V	4 MHz	X	V	V
	I _{IDLE152}	-	1	-	mA	2.2 V	4 MHz	X	V	X
Operating Current Idle Mode HCLK =16 MHz V _{LDO} =1.6 V	I _{IDLE153}	-	4.3	-	mA	V _{DD}	HXT	HIRC0	PLL	All digital module
						3.6 V	X	16 MHz	X	V
	I _{IDLE154}	-	1.1	-	mA	3.6 V	X	16 MHz	X	X
	I _{IDLE155}	-	4.3	-	mA	2.2 V	X	16 MHz	X	V
Operating Current Idle Mode HCLK =16 MHz V _{LDO} =1.6 V	I _{IDLE156}	-	1	-	mA	2.2 V	X	16 MHz	X	X
	I _{IDLE157}	-	4.4	-	mA	3.6 V	X	12 MHz	V	V
	I _{IDLE158}	-	1.3	-	mA	3.6 V	X	12 MHz	V	X
	I _{IDLE159}	-	4.4	-	mA	2.2 V	X	12 MHz	V	V
Operating Current Idle Mode HCLK =16 MHz V _{LDO} =1.6 V	I _{IDLE160}	-	1.2	-	mA	2.2 V	X	12 MHz	V	X
	I _{IDLE161}	-	3.8	-	mA	V _{DD}	HXT	MIRC	PLL	All digital module
						3.6 V	X	4 MHz	V	V
	I _{IDLE162}	-	1	-	mA	3.6 V	X	4 MHz	V	X
I _{IDLE163}	-	3.8	-	mA	2.2 V	X	4 MHz	V	V	
Operating Current Idle Mode HCLK =12 MHz V _{LDO} =1.6 V	I _{IDLE164}	-	1	-	mA	2.2 V	X	4 MHz	V	X
	I _{IDLE165}	-	3	-	mA	V _{DD}	HXT	HIRC0	PLL	All digital module
						3.6 V	12 MHz	X	X	V
I _{IDLE166}	-	0.9	-	mA	3.6 V	12 MHz	X	X	X	
I _{IDLE167}	-	3	-	mA	2.2 V	12 MHz	X	X	V	

PARAMETER	SYM.	SPECIFICATIONS				TEST CONDITIONS				
		MIN.	TYP.	MAX.	UNIT					
	I _{IDLE168}	-	0.9	-	mA	2.2 V	12 MHz	X	X	X
Operating Current Idle Mode HCLK =12 MHz V _{LDO} =1.6 V	I _{IDLE169}	-	3	-	mA	3.6 V	4 MHz	X	V	V
	I _{IDLE170}	-	0.9	-	mA	3.6 V	4 MHz	X	V	X
	I _{IDLE171}	-	3	-	mA	2.2 V	4 MHz	X	V	V
	I _{IDLE172}	-	0.9	-	mA	2.2 V	4 MHz	X	V	X
Operating Current Idle Mode HCLK =12 MHz V _{LDO} =1.6 V	I _{IDLE173}	-	3.4	-	mA	V _{DD}	HXT	HIRC0	PLL	All digital module
						3.6 V	X	12 MHz	X	V
	I _{IDLE174}	-	0.9	-	mA	3.6 V	X	12 MHz	X	X
	I _{IDLE175}	-	3.3	-	mA	2.2 V	X	12 MHz	X	V
Operating Current Idle Mode HCLK =12 MHz V _{LDO} =1.6 V	I _{IDLE176}	-	0.9	-	mA	2.2 V	X	12 MHz	X	X
						2.2 V	X	12 MHz	X	X
	I _{IDLE177}	-	3	-	mA	V _{DD}	HXT	MIRC	PLL	All digital module
						3.6 V	X	4 MHz	V	V
I _{IDLE178}	-	0.9	-	mA	3.6 V	X	4 MHz	V	X	
I _{IDLE179}	-	2.9	-	mA	2.2 V	X	4 MHz	V	V	
Operating Current Idle Mode HCLK =4 MHz V _{LDO} =1.6 V	I _{IDLE180}	-	0.9	-	mA	2.2 V	X	4 MHz	V	X
						2.2 V	X	4 MHz	V	X
	I _{IDLE181}	-	0.8	-	mA	V _{DD}	HXT	HIRC0	PLL	All digital module
						3.6 V	4 MHz	X	X	V
I _{IDLE182}	-	0.4	-	mA	3.6 V	4 MHz	X	X	X	
I _{IDLE183}	-	0.8	-	mA	2.2 V	4 MHz	X	X	V	
Operating Current Idle Mode HCLK =4 MHz V _{LDO} =1.6 V	I _{IDLE184}	-	0.4	-	mA	2.2 V	4 MHz	X	X	X
						2.2 V	4 MHz	X	X	X
	I _{IDLE185}	-	1.1	-	mA	V _{DD}	HXT	MIRC	PLL	All digital module
						3.6 V	X	4 MHz	V	V
I _{IDLE186}	-	0.4	-	mA	3.6 V	X	4 MHz	V	X	
I _{IDLE187}	-	1.1	-	mA	2.2 V	X	4 MHz	V	V	
I _{IDLE188}	-	0.4	-	mA	2.2 V	X	4 MHz	V	X	
Operating Current Idle Mode HCLK =32.768 kHz V _{LDO} =1.6 V	I _{IDLE189}	-	143	-	μA	V _{DD}	LXT	LIRC	PLL	All digital module
						3.6 V	32.768 kHz	X	X	V
	I _{IDLE190}	-	138	-	μA	3.6 V	32.768 kHz	X	X	X
	I _{IDLE191}	-	120	-	μA	2.2 V	32.768 kHz	X	X	V
Operating Current Idle Mode HCLK =10 kHz	I _{IDLE192}	-	115	-	μA	2.2 V	32.768 kHz	X	X	X
	I _{IDLE193}	-	138	-	μA	3.6 V	X	10 kHz	X	V
I _{IDLE194}	-	136	-	μA	3.6 V	X	10 kHz	X	X	

PARAMETER	SYM.	SPECIFICATIONS				TEST CONDITIONS				
		MIN.	TYP.	MAX.	UNIT					
V _{LDO} =1.6 V	I _{IDLE195}	-	116	-	μA	2.2 V	X	10 kHz	X	V
	I _{IDLE196}	-	114	-	μA	2.2 V	X	10 kHz	X	X
Operating Current Idle Mode HCLK =2 MHz V _{LDO} =1.2 V	I _{IDLE197}	-	0.7	-	mA	V _{DD}	HXT	MIRC	PLL	All digital module
						3.6 V	4 MHz	X	X	V
	I _{IDLE198}	-	0.4	-	mA	3.6 V	4 MHz	X	X	X
	I _{IDLE199}	-	0.7	-	mA	2.2 V	4 MHz	X	X	V
Operating Current Idle Mode HCLK =2 MHz V _{LDO} =1.2 V	I _{IDLE201}	-	0.7	-	mA	V _{DD}	HXT	MIRC	PLL	All digital module
						3.6 V	X	4 MHz	X	V
	I _{IDLE202}	-	0.3	-	mA	3.6 V	X	4 MHz	X	X
	I _{IDLE203}	-	0.7	-	mA	2.2 V	X	4 MHz	X	V
Operating Current Idle Mode HCLK =2 MHz V _{LDO} =1.2 V	I _{IDLE204}	-	0.3	-	mA	2.2 V	X	4 MHz	X	X
						2.2 V	X	4 MHz	X	X
	I _{IDLE205}	-	215	-	μA	V _{DD}	LXT	LIRC	PLL	All digital module
						3.6 V	32.768 kHz	X	X	V
Operating Current Idle Mode HCLK =32.768 kHz V _{LDO} =1.2 V	I _{IDLE206}	-	211	-	μA	3.6 V	32.768 kHz	X	X	X
	I _{IDLE207}	-	204	-	μA	2.2 V	32.768 kHz	X	X	V
	I _{IDLE208}	-	200	-	μA	2.2 V	32.768 kHz	X	X	X
						2.2 V	32.768 kHz	X	X	X
Operating Current Idle Mode HCLK =10 kHz V _{LDO} =1.2 V	I _{IDLE209}	-	122	-	μA	V _{DD}	LXT	LIRC	PLL	All digital module
						3.6 V	X	10 kHz	X	V
	I _{IDLE210}	-	132	-	μA	3.6 V	X	10 kHz	X	X
	I _{IDLE211}	-	112	-	μA	2.2 V	X	10 kHz	X	V
Standby Current Power-down Mode V _{LDO} =1.8 V	I _{PWD1}	-	1.7	-	μA	V _{DD}	HXT/HIRC/PLL	LXT(kHz)	RTC	RAM retention
						3.6 V	X	X	X	V
	I _{PWD2}	-	2.3	-	μA	3.6 V	X	32.768	V	V
	I _{PWD3}	-	1.6	-	μA	2.2 V	X	X	X	V
Standby Current Power-down Mode V _{LDO} =1.6 V	I _{PWD4}	-	2.2	-	μA	2.2 V	X	32.768	V	V
	I _{PWD5}	-	1.6	-	μA	3.6 V	X	X	X	V
	I _{PWD6}	-	2.2	-	μA	3.6 V	X	32.768	V	V
	I _{PWD7}	-	1.5	-	μA	2.2 V	X	X	X	V
Standby Current	I _{PWD8}	-	2.1	-	μA	2.2 V	X	32.768	V	V
Standby Current	I _{PWD9}	-	1.6	-	μA	3.6 V	X	X	X	V

PARAMETER	SYM.	SPECIFICATIONS				TEST CONDITIONS				
		MIN.	TYP.	MAX.	UNIT					
Power-down Mode $V_{LDO}=1.2\text{ V}$	I_{PWD10}	-	2.1	-	μA	3.6 V	X	32.768	V	V
	I_{PWD11}	-	1.4	-	μA	2.2 V	X	X	X	V
	I_{PWD12}	-	2.0	-	μA	2.2 V	X	32.768	V	V

Input Pull Up Resistor PA, PB, PC, PD, PE, PF	R_{IN}	-	42	-	$k\Omega$	$V_{DD} = 3.3\text{ V}$
		-	106	-	$k\Omega$	$V_{DD} = 2.2\text{ V}$
Input Leakage Current PA, PB, PC, PD, PE, PF	I_{LK}	-1	-	1	μA	$V_{DD} = 3.3\text{ V}, 0 < V_{IN} < V_{DD}$
Input Low Voltage PA, PB, PC, PD, PE, PF (Schmitt input)	V_{IL1}	-	-	$0.3 \cdot V_{DD}$	V	
Input High Voltage PA, PB, PC, PD, PE, PF (Schmitt input)	V_{IH1}	$0.7 \cdot V_{DD}$	-	-	V	ADC/ACMP/HXT/LXT shared pins and PA.8/PB.4/PB.5 pins without Input 5 V tolerance.
Hysteresis voltage of PA~PF (Schmitt input)	V_{HY}	-	$0.4 \cdot V_{DD}$	-	V	
Negative going threshold (Schmitt input), /RESET	V_{ILS}	-	-	$0.3 \cdot V_{DD}$	V	$V_{DD} = 3.3\text{ V}$
Positive going threshold (Schmitt Input), /RESET	V_{IHS}	$0.7 \cdot V_{DD}$	-	-	V	$V_{DD} = 3.3\text{ V}$
Source Current PA, PB, PC, PD, PE, PF (Push-pull Mode)	I_{SR21}	-	-18	-	mA	$V_{DD} = 3.3\text{ V},$ $V_S = 2.4\text{ V}$
	I_{SR22}	-	-2.5	-	mA	$V_{DD} = 2.2\text{ V},$ $V_S = 1.6\text{ V}$
Sink Current PA, PB, PC, PD, PE, PF (Push-pull Mode)	I_{SK21}	-	12	-	mA	$V_{DD} = 3.3\text{ V},$ $V_S = 0.45\text{ V}$
	I_{SK22}	-	6	-	mA	$V_{DD} = 2.2\text{ V},$ $V_S = 0.45\text{ V}$

Note:

1. /RESET pin is a Schmitt trigger input.
2. Crystal Input is a CMOS input.
3. It is recommended that a 10 μF or higher capacitor and a 100 nF bypass capacitor are connected between V_{DD} and the closest V_{SS} pin of the device.
4. For ensuring power stability, a 1 μF or higher capacitor must be connected between LDO pin and the closest V_{SS} pin of the device. Also a 100 nF bypass capacitor between LDO and V_{SS} help suppressing output noise.
5. All peripherals' clock source is from HXT (12 MHz), except SPI from HCLK.
6. The Operating Current (Normal Run Mode and Idle Mode) test condition is enable LVR and Clock filter.

9.3 AC Electrical Characteristics

9.3.1 External Input Clock

PARAMETER	SYM.	SPECIFICATIONS				TEST CONDITION
		MIN.	TYP.	MAX.	UNIT	
Clock High Time	t_{CHCX}	10	-	-	ns	
Clock Low Time	t_{CLCX}	10	-	-	ns	
Clock Rise Time	t_{CLCH}	2	-	15	ns	
Clock Fall Time	t_{CHCL}	2	-	15	ns	

Note: Duty cycle is 50%.

9.3.2 External 4~24 MHz XTAL Oscillator

PARAMETER	SYM.	SPECIFICATIONS				TEST CONDITION
		MIN.	TYP.	MAX.	UNIT	
Oscillator frequency	f_{HXT}	4	12	24	MHz	$V_{DD} = 2.2\text{ V} \sim 3.6\text{ V}$
Temperature	T_{HXT}	-40	-	+105	°C	
Operating current	I_{HXT}	-	450	-	μA	$V_{DD} = 3.3\text{ V}$

9.3.2.1 Typical Crystal Application Circuits

CRYSTAL	C1	C2	R1
4 MHz ~ 24 MHz	20 pF	20 pF	without

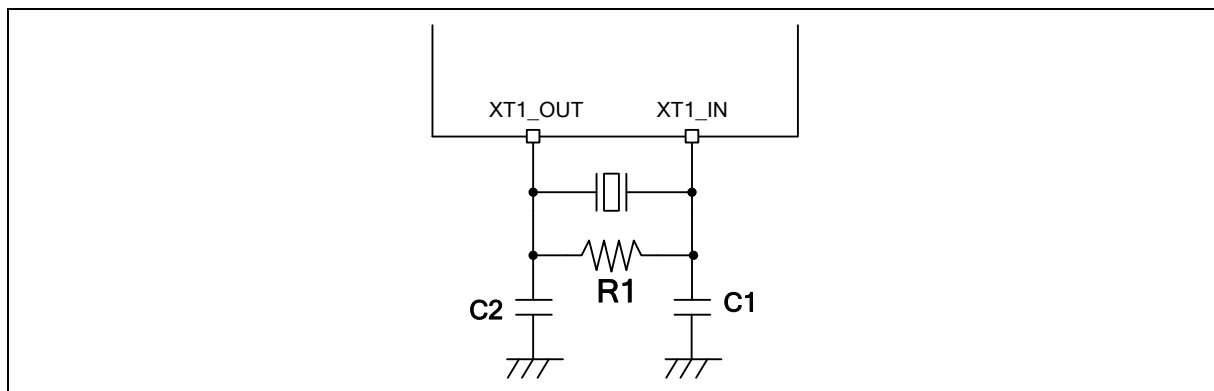

Figure 9-1 Typical High Speed Crystal Application Circuit

9.3.3 External 32.768 kHz Crystal

PARAMETER	SYM.	SPECIFICATIONS				TEST CONDITION
		MIN.	TYP.	MAX.	UNIT	
Oscillator frequency	f_{LXT}	-	32.768	-	kHz	$V_{DD} = 2.2\text{ V} \sim 3.6\text{ V}$
Temperature	T_{LXT}	-40	-	+105	°C	
Operating current	I_{LXT}	-	1.42	-	μA	$V_{DD} = 3.3\text{ V}$, Testing crystal ESR = 50 kΩ

Note:

1. The 32.768 kHz crystal must fit the specifications for working in any situation normally.
2. Equivalent series resistance (ESR) of crystal should be less than 50 kΩ (max. 50 kΩ).
3. The load capacitance should be 12.5 pF.
4. The specifications based on crystal "XD36RU000032C9" from vendor Aurumtec.

9.3.3.1 Typical Crystal Application Circuits

CRYSTAL	C3	C4	R2
32.768 kHz	20 pF	20 pF	without

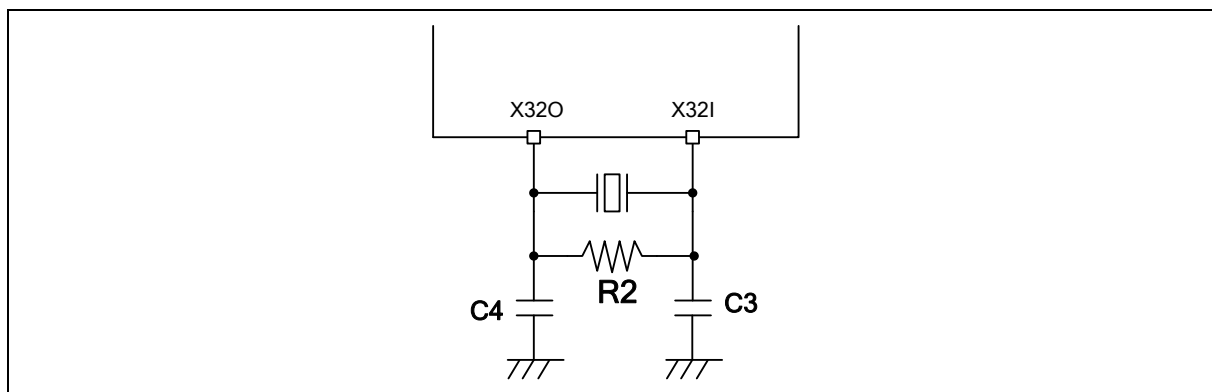

Figure 9-2 Typical Low Speed Crystal Application Circuit

9.3.4 Internal 36 MHz Oscillator

PARAMETER	SYM.	SPECIFICATIONS				TEST CONDITION
		MIN.	TYP.	MAX.	UNIT	
Supply voltage[1]	V _{HRC}	-	1.5	-	V	
Calibrated Internal Oscillator Frequency	F _{HRC}	35.64	36	36.36	MHz	25 °C, V _{DD} = 3.3 V
		35.28	36	36.72	MHz	-40 °C ~ +105 °C, V _{DD} = 2.2 V~3.6 V
		35.64	36	35.36	MHz	-40 °C ~ +105 °C, V _{DD} = 2.2 V~3.6 V Enable 32.768 kHz crystal oscillator and set TRIM_SEL[1:0]="10"
Operating current	I _{HRC}	-	85	-	μA	

9.3.5 Internal 12 MHz Oscillator

PARAMETER	SYM.	SPECIFICATIONS				TEST CONDITION
		MIN.	TYP.	MAX.	UNIT	
Supply voltage[1]	V _{HRC}	-	1.8	-	V	
Calibrated Internal Oscillator Frequency	F _{HRC}	11.88	12	12.12	MHz	25 °C, V _{DD} = 3.3 V
		11.76	12	12.24	MHz	-40 °C ~ +105 °C, V _{DD} = 2.2 V~3.6 V
		11.88	12	12.12	MHz	-40 °C ~ +105 °C, V _{DD} = 2.2 V~3.6 V Enable 32.768 kHz crystal oscillator and set TRIM_SEL[1:0]="10"
Operating current	I _{HRC}	-	210	-	μA	

Note: Internal oscillator operation voltage comes from LDO.

9.3.6 Internal 4 MHz Oscillator

PARAMETER	SYM.	SPECIFICATIONS				TEST CONDITION
		MIN.	TYP.	MAX.	UNIT	
Supply voltage[1]	V _{HRC}	-	1.5	-	V	
Calibrated Internal Oscillator Frequency	F _{HRC}	3.96	4	4.04	MHz	25 °C, V _{DD} = 3.3 V
		3.88	4	4.08	MHz	-40 °C ~ +105 °C, V _{DD} = 2.2 V~3.6 V
		3.92	4	4.04	MHz	-40 °C ~ +105 °C, V _{DD} = 2.2 V~3.6 V Enable 32.768 kHz crystal oscillator and set TRIM_SEL[1:0]="10"
Operating current	I _{HRC}	-	20	-	μA	

9.3.7 Internal 10 kHz Oscillator

PARAMETER	SYM.	SPECIFICATIONS				TEST CONDITION
		MIN.	TYP.	MAX.	UNIT	
Supply voltage[1]	V _{LRC}	-	1.8	-	V	
Center Frequency	F _{LRC}	7	10	13	kHz	25 °C, V _{DD} = 3.3 V
		5	10	15	kHz	-40 °C ~+105 °C, V _{DD} = 2.2 V~3.6 V
Operating current	I _{LRC}	-	0.5	-	μA	V _{DD} = 3.3 V

Note: Internal oscillator operation voltage comes from LDO.

9.4 Analog Characteristics

9.4.1 12-bit ADC

PARAMETER	SYM.	SPECIFICATIONS				TEST CONDITION
		MIN.	TYP.	MAX.	UNIT	
Operating voltage	V_{DD}	2.2	-	3.6	V	$V_{DD} = V_{DD}$
Operating current (V_{DD} current) (Enable ADC and disable all other analog modules)	I_{ADC32}	-	125	-	μA	$V_{DD} = V_{DD} = 3.6 V$ $ADC_VREF = V_{DD}$ ADC Clock Rate = 36 MHz
	I_{ADC2}	-	20	-	μA	$V_{DD} = V_{DD} = 3.6 V$ $ADC_VREF = V_{DD}$ ADC Clock Rate = 6 MHz
Resolution	R_{ADC}	-	-	12	Bit	
Reference voltage	V_{REF}	2.2	-	V_{DD}	V	
Reference input current (Avg.)	I_{REF}	-	-	1	μA	
ADC input voltage	V_{IN}	0	-	V_{REF}	V	
Conversion time	T_{CONV}	1	-	-	μs	
Conversion Rate	F_{SPS}	-	-	1.8M	Hz	$V_{DD} = 3.6 V$
Integral Non-Linearity Error	INL	-	± 1	-	LSB	V_{REF} is external Vref pin
Differential Non-Linearity	DNL	-	± 0.8	-	LSB	V_{REF} is external Vref pin
Gain error	E_G	-	± 2	-	LSB	V_{REF} is external Vref pin
Offset error	E_{OFFSET}	-	± 1.5	-	LSB	V_{REF} is external Vref pin
Absolute error	E_{ABS}	-	-	± 6	LSB	V_{REF} is external Vref pin
ADC Clock frequency	F_{ADC}	0.25	-	36	MHz	
Clock cycle	AD_{CYC}	20	-	-	Cycle	
Internal Capacitance	C_{IN}	-	5	-	pF	
Monotonic	-	Guaranteed		-		

9.4.2 Brown-out Detector

Symbol	Parameter	Min	Typ	Max	Unit	Test Condition
V_{DD}	Supply Voltage	0	-	3.6	V	-
T_A	Temperature	-40	25	105	°C	-
I_{BOD}	Quiescent Current	-	40	-	μA	$V_{DD} = 3.6\text{ V}$
I_{LPBOD}	Quiescent Current	-	0.5	-	μA	$V_{DD} = 3.6\text{ V}$
V_{BOD}	Brown-out Voltage 25 °C	1.75	1.8	1.79	V	BODCTL[15:12] = 0001
		1.84	1.9	1.89	V	BODCTL[15:12] = 0010
		1.94	2.0	1.99	V	BODCTL[15:12] = 0011
		2.04	2.1	2.09	V	BODCTL[15:12] = 0100
		2.14	2.2	2.19	V	BODCTL[15:12] = 0101
		2.23	2.3	2.29	V	BODCTL[15:12] = 0110
		2.33	2.4	2.39	V	BODCTL[15:12] = 0111
		2.43	2.5	2.49	V	BODCTL[15:12] = 1000
		2.53	2.6	2.59	V	BODCTL[15:12] = 1001
		2.62	2.7	2.69	V	BODCTL[15:12] = 1010
		2.72	2.8	2.79	V	BODCTL[15:12] = 1011
		2.82	2.9	2.89	V	BODCTL[15:12] = 1100
		2.92	3	2.99	V	BODCTL[15:12] = 1101
3.02	3.1	3.09	V	BODCTL[15:12] = 1110		
V_{LPBOD}	Low Power Mode Brown-out Voltage 25 °C	2.01	2.0	2.07	V	BODCTL[9] = 0
		2.42	2.5	2.79	V	BODCTL[9] = 1

9.4.3 Power-on Reset

Symbol	Parameter	Min	Typ	Max	Unit	Test Condition
T _A	Temperature	-40	25	105	°C	-
V _{POR}	Threshold Voltage	-	1.5	-	V	-

9.4.4 Low-Voltage Reset

Symbol	Parameter	Min	Typ	Max	Unit	Test Condition
T _A	Temperature	-40	25	105	°C	-
V _{POR}	Threshold Voltage	-	1.68	-	V	-

9.4.5 Temperature Sensor

PARAMETER	SYM.	SPECIFICATIONS				TEST CONDITION (supply voltage = 3V)
		MIN.	TYP.	MAX.	UNIT	
Detection Temperature	T _{DET}	-40		+105	°C	
Operating current	I _{TEMP}	-	5	-	μA	
Gain	V _{TG}	-1.64	-1.70	-1.76	mV/°C	
Offset	V _{TO}	735	745	755	mV	Temperature at 0 °C

Note: Internal operation voltage comes from LDO.

9.4.6 Internal Voltage Reference

PARAMETER	SYM.	SPECIFICATIONS				TEST CONDITION
		MIN.	TYP.	MAX.	UNIT	
Operating voltage	AV _{DD}	2.2	-	3.6	V	
1.5V voltage reference	V _{REF1}	1.43	1.5	1.58	V	AV _{DD} ≥ 2.2 V (-40 °C ~105 °C)
1.8V voltage reference	V _{REF2}	1.71	1.8	1.89	V	AV _{DD} ≥ 2.2 V (-40 °C ~105 °C)
2.5V voltage reference	V _{REF3}	2.37	2.5	2.63	V	AV _{DD} ≥ 2.8 V (-40 °C ~105 °C)
Stable Time	T _{REFTAB}	-	1	-	ms	I _{LOAD} =1 mA, C = 1 μF
1.5V operating current	I _{VREF1}	-	125	-	μA	AV _{DD} = 3.3 V
1.8V operating current	I _{VREF2}	-	130	-	μA	AV _{DD} = 3.3 V
2.5V operating current	I _{VREF3}	-	140	-	μA	AV _{DD} = 3.3 V

9.4.7 Comparator

Symbol	Parameter	Min	Typ	Max	Unit	Test Condition
V _{CMP}	Supply Voltage	2.2	-	3.6	V	
T _A	Temperature	-40	25	105	°C	-
I _{CMP}	Operation Current	-	40	-	μA	AV _{DD} = 3.3 V
V _{OFF}	Input Offset Voltage	-	10	TBD	mV	-
V _{SW}	Output Swing	0.1	-	AV _{DD} - 0.1	V	-
V _{COM}	Input Common Mode Range	0.1	-	AV _{DD} - 0.1	V	-
-	DC Gain	40	70	-	dB	-
T _{PGD1}	Propagation Delay(HYS=0)	-	280	TBD	ns	V _{DIFF} = 100 mV,
T _{PGD2}	Propagation Delay(HYS=1)	-	440	TBD	μs	V _{DIFF} = 100 mV
V _{HYS}	Hysteresis	-	±60	-	mV	
T _{STB}	Stable time	-	1	TBD	μs	

10 PACKAGE DIMENSIONS**10.1 64S LQFP (7 x 7 mm². Thickness 1.4 mm)**

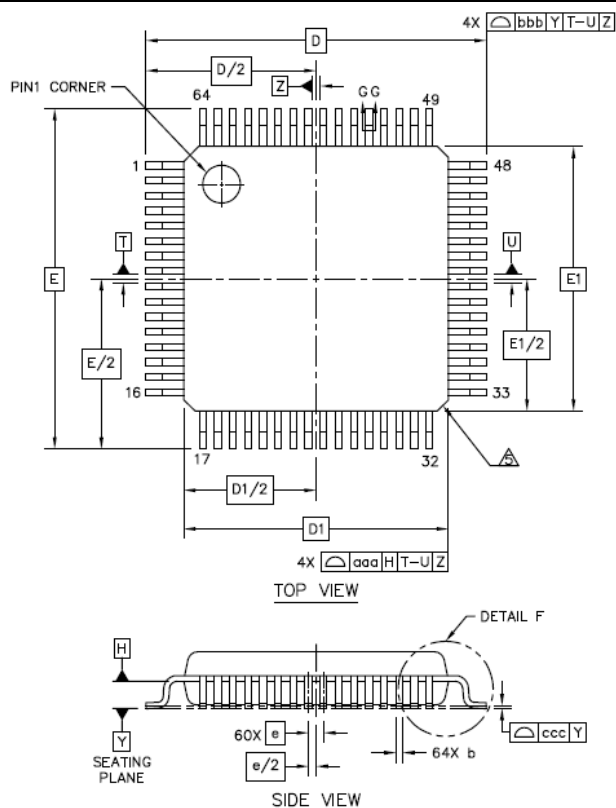

	SYMBOL	MIN	NOM	MAX
TOTAL THICKNESS	A	---	---	1.6
STAND OFF	A1	0.05	---	0.15
MOLD THICKNESS	A2	1.35	1.4	1.45
LEAD WIDTH(PLATING)	b	0.13	0.18	0.23
LEAD WIDTH	b1	0.13	0.16	0.19
L/F THICKNESS(PLATING)	c	0.09	---	0.2
L/F THICKNESS	c1	0.09	---	0.16
BODY SIZE	X	D	9 BSC	
	Y	E	9 BSC	
BODY SIZE	X	D1	7 BSC	
	Y	E1	7 BSC	
LEAD PITCH	e	0.4 BSC		
	L	0.45	0.6	0.75
FOOTPRINT	L1	1 REF		
	θ	0°	3.5°	7°
	θ1	0°	---	---
	θ2	11°	12°	13°
	θ3	11°	12°	13°
	R1	0.08	---	---
	R2	0.08	---	0.2
	S	0.2	---	---
PACKAGE EDGE TOLERANCE	aaa	0.2		
LEAD EDGE TOLERANCE	bbb	0.2		
COPLANARITY	ccc	0.08		
LEAD OFFSET	ddd	0.07		
MOLD FLATNESS	eee	0.05		

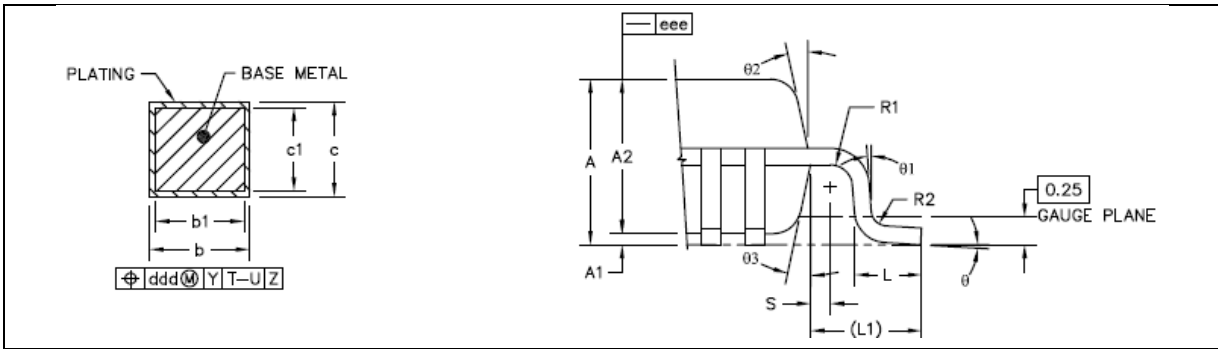

10.2 48L LQFP (7 x 7 mm². Thickness 1.4 mm)

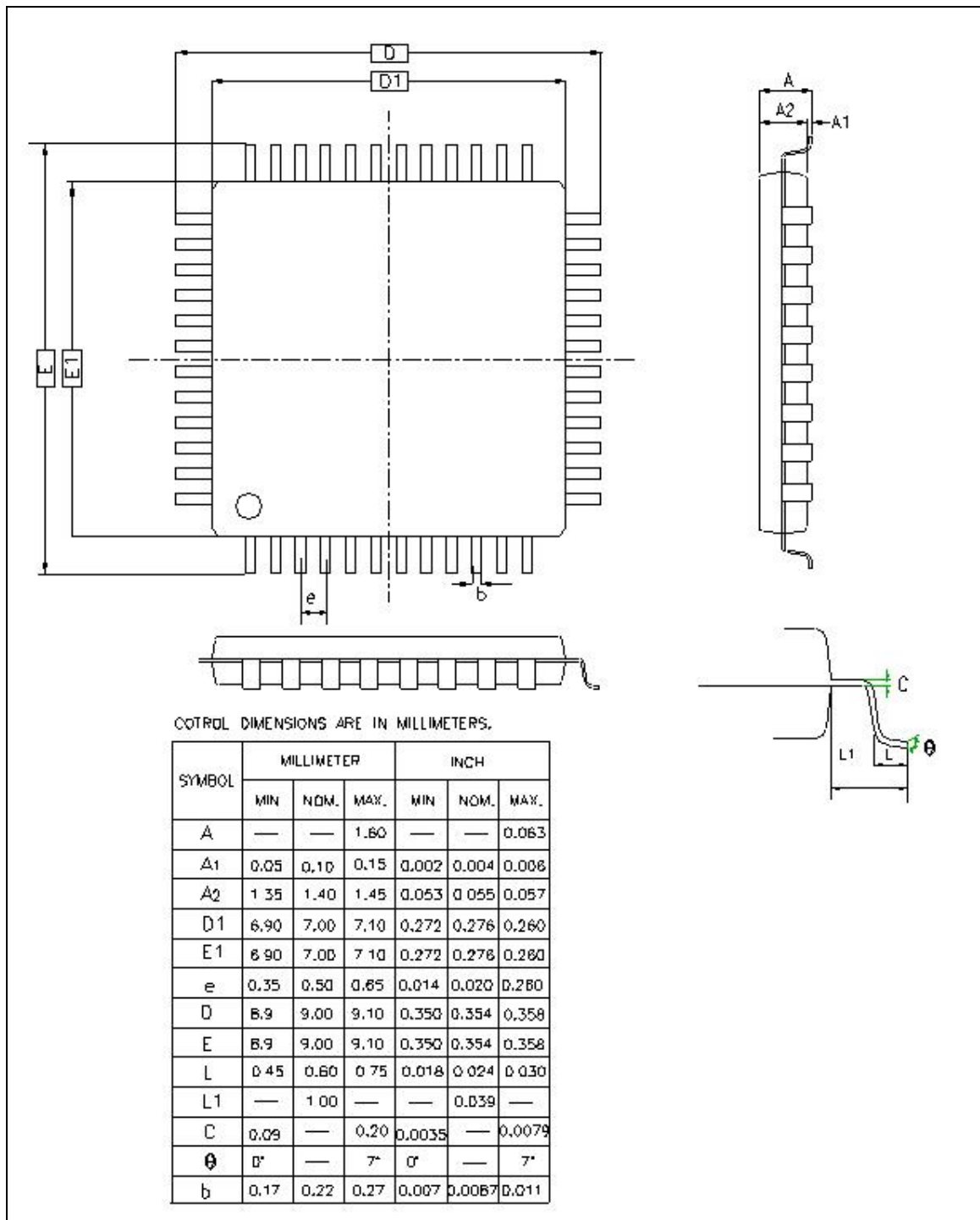

10.3 33L QFN (5 x 5 mm². Thickness 0.8 mm)

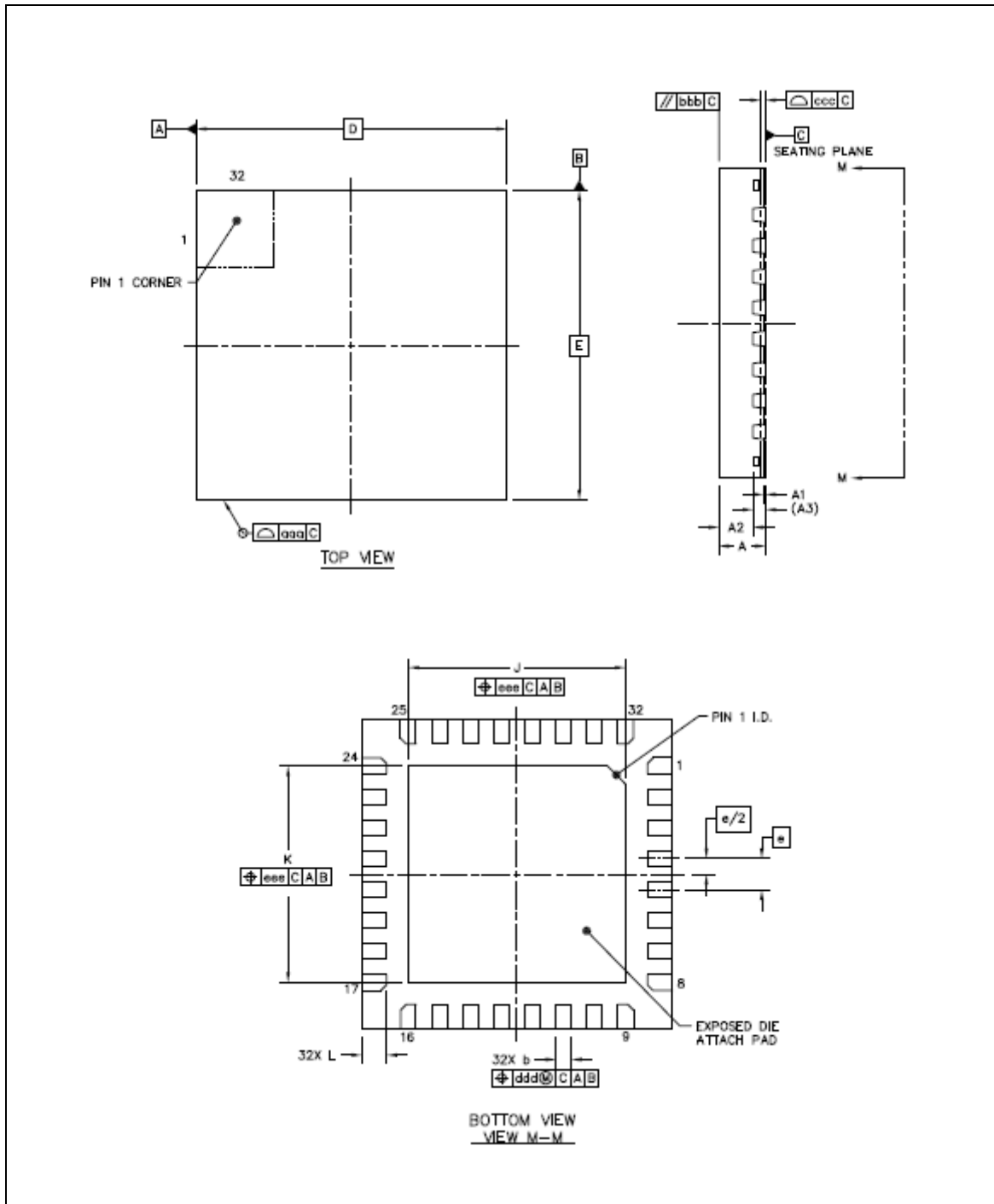

NANO103 SERIES DATASHEET

		SYMBOL	MIN	NOM	MAX
TOTAL THICKNESS		A	0.7	0.75	0.8
STAND OFF		A1	0	0.035	0.05
MOLD THICKNESS		A2	---	0.55	0.57
L/F THICKNESS		A3	0.203 REF		
LEAD WIDTH		b	0.2	0.25	0.3
BODY SIZE	X	D	5 BSC		
	Y	E	5 BSC		
LEAD PITCH		e	0.5 BSC		
EP SIZE	X	J	3.4	3.5	3.6
	Y	K	3.4	3.5	3.6
LEAD LENGTH		L	0.35	0.4	0.45
PACKAGE EDGE TOLERANCE		aaa	0.1		
MOLD FLATNESS		bbb	0.1		
COPLANARITY		ccc	0.08		
LEAD OFFSET		ddd	0.1		
EXPOSED PAD OFFSET		eee	0.1		

11 REVISION HISTORY

Date	Revision	Description
2016.07.01	1.00	1. Initial version
		1. Revised Temperature Selection Code in section 4.1. 2. Revised Uart channel number in section 4.2. 3. Revised I/O ports number in section 5.1.
2018.05.02	1.01	4. Revised Supply Voltage Range in chapter 1, chapter 2, section 6.5 and chapter 9. 5. Removed invalid cross-references in section 6.8.1. 6. Revised external 32.768 kHz crystal characteristics in section 9.3.3. 7. Removed SPROM and KPROM discription in chapter 1 and 2, and section 5.1 and 6.4.
		1. Revised Selection Code in section 4.1. 2. Removed 32 KB APROM description in section 6.4. 3. Revised application circuit in chapter 7. 4. Revised package size in chapter 10.
2020.01.21	1.02	

Important Notice

Nuvoton Products are neither intended nor warranted for usage in systems or equipment, any malfunction or failure of which may cause loss of human life, bodily injury or severe property damage. Such applications are deemed, "Insecure Usage".

Insecure usage includes, but is not limited to: equipment for surgical implementation, atomic energy control instruments, airplane or spaceship instruments, the control or operation of dynamic, brake or safety systems designed for vehicular use, traffic signal instruments, all types of safety devices, and other applications intended to support or sustain life.

All Insecure Usage shall be made at customer's risk, and in the event that third parties lay claims to Nuvoton as a result of customer's Insecure Usage, customer shall indemnify the damages and liabilities thus incurred by Nuvoton.

*Please note that all data and specifications are subject to change without notice.
All the trademarks of products and companies mentioned in this datasheet belong to their respective owners.*