

## GENERAL DESCRIPTION

OB2235x is a high performance, high precision and low cost PWM Power switch for non-isolated buck and buck-boost application. It combines a dedicated current mode PWM controller with a high voltage power Mosfet in DIP7,DIP8&SOP8 package. Its built-in error amplifier is optimized for good overshoot and dynamic response for low cost and component count. With precise inner resistor divider, precise reference of EA, constant voltage regulation of 12V at universal AC input can be guaranteed. Frequency reduction and burst mode control is implemented for high efficiency at light load. Good EMI performance is achieved with On-Bright proprietary frequency shuffling technique and soft gate driver design. Low startup current and low operating current contribute to a reliable power on startup and low standby power consumption with OB2235x.

OB2235x offers power on soft start control and protection coverage with auto-recovery features including cycle-by-cycle current limiting, output short circuit protection, on-chip Over Temperature Protection (OTP), VDD Over Voltage Protection (OVP), Over Loading Protection(OLP) and VDD Under Voltage Lockout Protection (UVLO).

The tone energy at below 20KHz is minimized in the design so that audio noise is eliminated during operation.

OB2235x is offered in DIP7,DIP8&SOP8 package.

## FEATURES

- Universal AC input range and 12V output voltage
- Low cost and less BOM for buck and buck-boost applications
- Current mode control
- 40kHz (typical) maximum switching frequency
- Frequency-reduction and burst mode control for high efficiency
- Frequency shuffling for EMI improvement
- Power on soft-start
- Built-in Leading Edge Blanking (LEB)
- Cycle-by-cycle current limiting
- Output short-circuit protection
- VDD Under Voltage Lockout with Hysteresis
- VDD OVP
- Over Loading Protection
- On-Chip OTP

## APPLICATIONS

Low power AC/DC offline SMPS for

- Small home appliance
- Linear regulator/RCC replacement

## TYPICAL APPLICATION

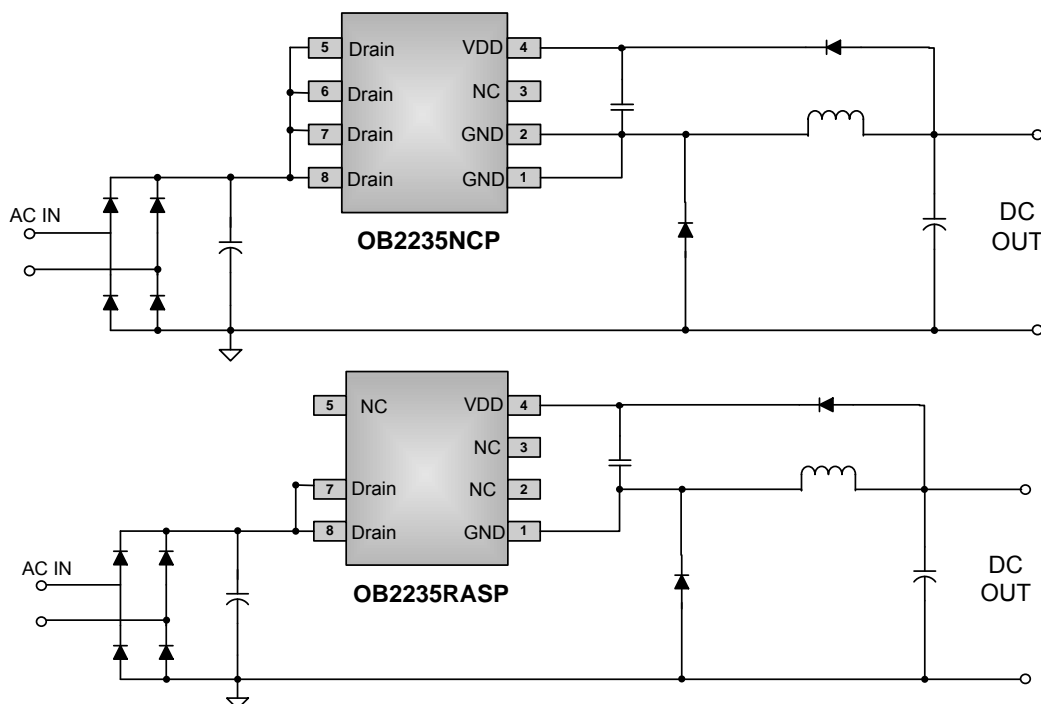

### GENERAL INFORMATION

#### Pin Configuration

The pin map is shown as below for DIP8

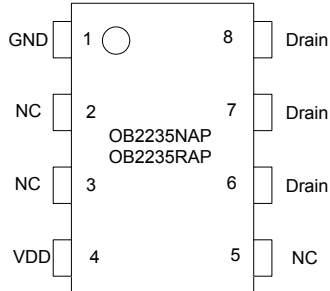

The pin map is shown as below for DIP7

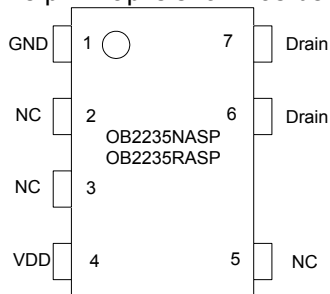

The pin map is shown as below for SOP8

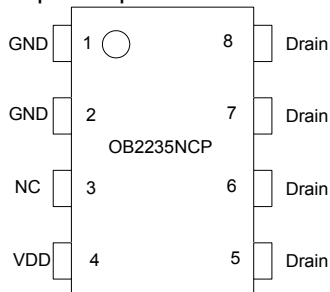

#### Ordering Information

Part Number	Description
OB2235NAP-H	DIP8, Halogen-free, Tube
OB2235NASP-H	DIP7, Halogen-free, Tube
OB2235NCP-H	SOP8, Halogen-free, Tube
OB2235NCPA-H	SOP8, Halogen-free, T&R
OB2235RAP-H	DIP8, Halogen-free, Tube
OB2235RASP-H	DIP7, Halogen-free, Tube

#### Package Dissipation Rating

Package	R $\theta$ JA (°C/W)
DIP8	70
DIP7	75
SOP8	85

Note: Drain Pin Connected 100mm<sup>2</sup> PCB copper clad.

#### Recommended Operating Condition

Symbol	Parameter	Range
VDD	VDD Supply Voltage	8 to 12V

#### Absolute Maximum Ratings

Parameter	Value
Drain Voltage(off state)	-0.3V to Bvdss
VDD Voltage	-0.3 to 18V
Min/Max Operating Junction Temperature T <sub>J</sub>	-40 to 150 °C
Operating Ambient Temperature T <sub>A</sub>	-40 to 85 °C
Min/Max Storage Temperature T <sub>stg</sub>	-55 to 150 °C
Lead Temperature (Soldering, 10secs)	260 °C

Note: Stresses beyond those listed under “absolute maximum ratings” may cause permanent damage to the device. These are stress ratings only, functional operation of the device at these or any other conditions beyond those indicated under “recommended operating conditions” is not implied. Exposure to absolute maximum-rated conditions for extended periods may affect device reliability.

#### Output Power Table

Buck/Buck-Boost	90~264Vac (open frame)
OB2235NAP-H	450mA
OB2235NASP-H	450mA
OB2235NCP-H	400mA
OB2235RAP-H	600mA
OB2235RASP-H	600mA

Note: Maximum continuous power with drain pattern connected 100mm<sup>2</sup> PCB copper clad, at 50 °C ambient.

Buck/Buck-Boost	90~264Vac (open frame)
OB2235NAP-H	350mA
OB2235NASP-H	350mA
OB2235NCP-H	300mA
OB2235RAP-H	500mA
OB2235RASP-H	500mA

Note: Maximum continuous power with drain pattern connected 100mm<sup>2</sup> PCB copper clad, at 85 °C ambient.

### Marking Information

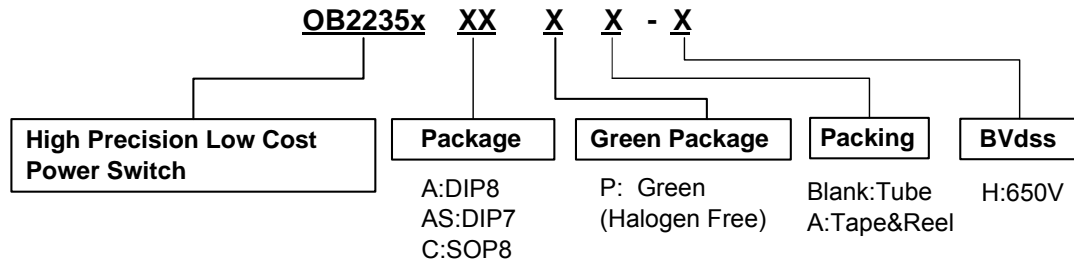

Y:Year Code  
WW:Week Code(01-52)  
ZZZ:Lot Code  
P:Halogen-free Package  
S:Internal Code(Optional)

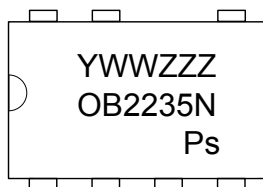

Y:Year Code  
WW:Week Code(01-52)  
ZZZ:Lot Code  
P:Halogen-free Package  
S:Internal Code(Optional)

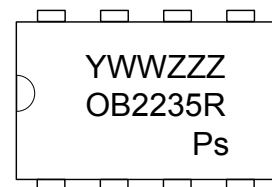

Y:Year Code  
WW:Week Code(01-52)  
ZZZ:Lot Code  
P:Halogen-free Package  
S:Internal Code(Optional)

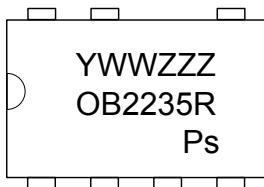

Y:Year Code  
WW:Week Code(01-52)  
ZZZ:Lot Code  
P:Halogen-free Package  
S:Internal Code(Optional)



Y:Year Code  
WW:Week Code(01-52)  
ZZZ:Lot Code  
P:Halogen-free Package  
S:Internal Code(Optional)

**TERMINAL ASSIGNMENTS****SOP8**

Pin Num	Pin Name	I/O	Description
1/2	GND	P	Ground
3	NC	NC	It should be floating or connect ground during normal operation state
4	VDD	I	Power Supply and Output Voltage Feedback
5/6/7/8	Drain	I	Power Mosfet Drain pins.

**DIP8**

Pin Num	Pin Name	I/O	Description
1	GND	P	Ground
2/3/5	NC	NC	It should be floating or connect ground during normal operation state
4	VDD	I	Power Supply and Output Voltage Feedback
6/7/8	Drain	I	Power Mosfet Drain pins.

**DIP7**

Pin Num	Pin Name	I/O	Description
1	GND	P	Ground
2/3/5	NC	NC	It should be floating or connect ground during normal operation state
4	VDD	I	Power Supply and Output Voltage Feedback
6/7	Drain	I	Power Mosfet Drain pins.

**BLOCK DIAGRAM**

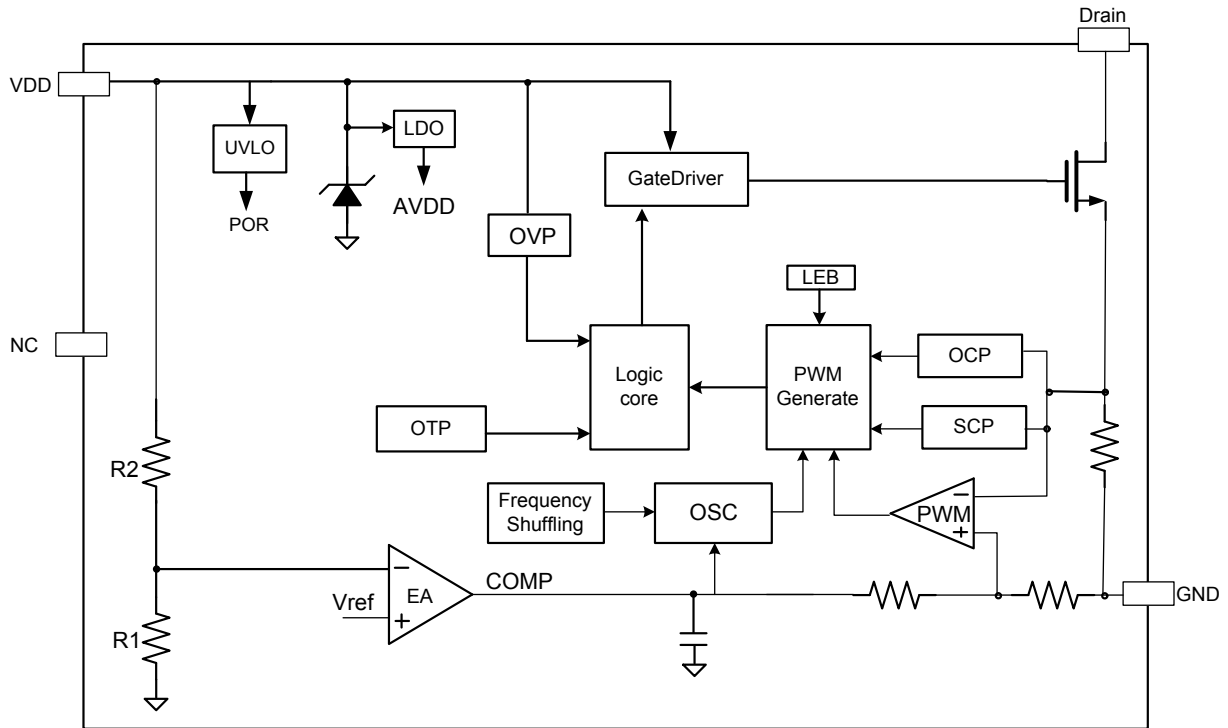

**ELECTRICAL CHARACTERISTICS**

 (T<sub>A</sub> = 25°C, VDD=12V, if not otherwise noted)

Symbol	Parameter	Test Conditions	Min	Typ.	Max	Unit
<b>Supply Voltage (VDD) Section</b>						
I <sub>startup</sub>	Standby Current1	VDD=0.1V		150		uA
	Standby Current2	VDD=UVLO (off) -0.5V		1.5		mA
I <sub>VDD_op</sub>	Operation Current	Operation supply current VDD=VOU <sub>SET</sub>	-	1.0	2.0	mA
		Operation supply current VDD=13V		0.45	0.6	mA
UVLO_ON	VDD Under Voltage Lockout Enter	VDD falling, gate disappear	6.5	7.0	7.5	V
UVLO_OFF	VDD Under Voltage Lockout Exit	VDD rising	12.5	13.5	14.5	V
OVP	Over voltage protection Threshold	Ramp VDD until gate shut down	16	17.5	19	V
VDD Regulation Voltage	In normal regulation, VDD will be regulated to average of 12.1V			12.1		V
<b>Frequency Section</b>						
Freq_Max	IC Maximum frequency		36	40	44	KHz
Δf/Freq	Frequency shuffling range			+/-8		%
F_shuffling	Shuffling frequency			75		Hz
Dmax	Maximum Duty Cycle		47	50	53	%
F_Burst	Burst Mode Switch Frequency			20		KHz
<b>Protection Section</b>						
Td_olp	Over Loading Debounce Time			130		ms
OTP	Power MOSFET temperature for exiting over temperature protection			123		°C
	Power MOSFET temperature for entering over temperature protection			153		°C
<b>Current Sense Input Section</b>						
Ith_oc	Over current detection threshold	OB2235N		0.7		A
		OB2235R		1.2		A
TLEB	LEB time	OB2235x		300		ns
Td_oc	OCP propagation delay	OB2235x		120		ns
<b>Power Mosfet Section</b>						
BVdss	MOSFET Drain-Source Breakdown Voltage	OB2235x	650			V
Rdson	On Resistance	OB2235N		9		Ω
		OB2235R		3.3		Ω

**CHARACTERIZATION PLOTS**

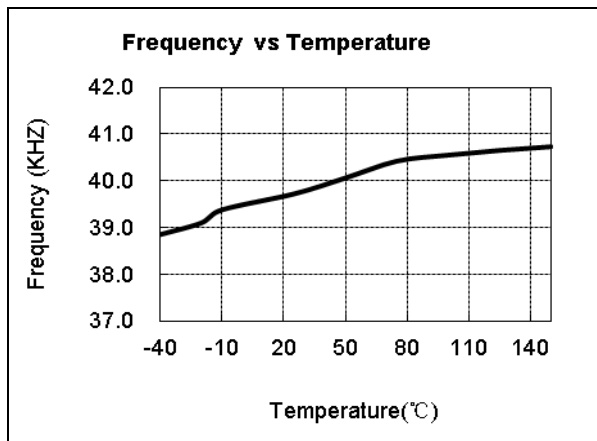
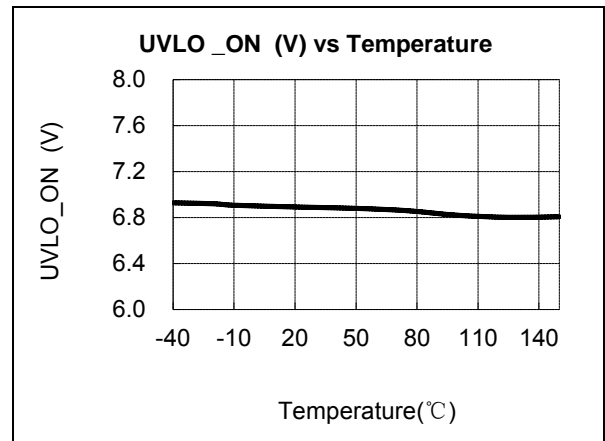
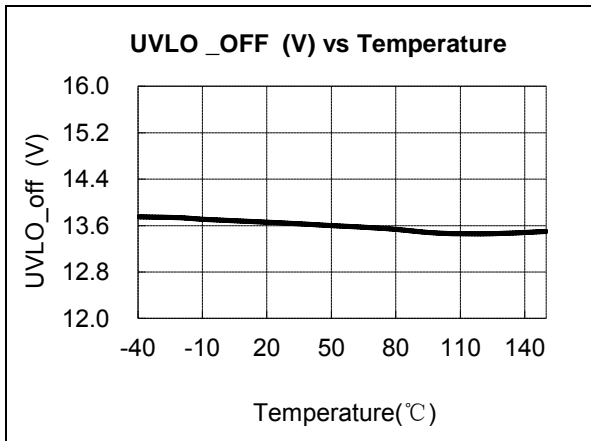

## OPERATION DESCRIPTION

OB2235x is a cost effective PWM power switch optimized for off-line non-isolated buck or buck-boost applications for small home appliances and linear regulator replacement. It operates in current mode and regulates output voltage with dedicated features. High integration can afford low cost and component count solution.

### Startup Current and Start up Control

Startup current of OB2235x is designed to be very low so that VDD could be charged up above UVLO threshold and starts up quickly.

### Operating Current

The Operating current of OB2235x is as low as 1.0mA (typical). Good efficiency is achieved with the low operation current together with 'Multi-mode' control features.

### PWM operation

The maximum switching frequency of OB2235x is internally fixed at 40KHz (typical). No external frequency setting components are required for PCB design simplification.

At light load or zero load condition, most of the power dissipation in a switching mode power supply is from switching loss on the MOSFET. The magnitude of power loss is in proportion to the switching frequency. Lower switching frequency leads to the reduction on the power loss and thus conserves the energy. The frequency reduction and burst mode operation are implemented to achieve high efficiency at light load. The minimum switching frequency is 20KHz (typical).

### Frequency shuffling for EMI improvement

The frequency shuffling (switching frequency modulation) is implemented in OB2235x. The oscillation frequency is modulated so that the tone energy is spread out. The spread spectrum minimizes the conduction band EMI and therefore eases the system design.

### Soft Start

OB2235x features an internal 75 cycles (typical) soft start to soften the electrical stress occurring in the power supply during startup. It is activated during the power on sequence. After VDD reaches UVLO(OFF), the switching frequency is gradually increased from 10KHz to 40KHz. Every restart up is followed by a soft start.

### Current Sensing and Leading Edge Blanking

Cycle-by-Cycle current limiting is offered in OB2235x current mode PWM control. The switch current is detected by a sense resistor within the OB2235x. An internal leading edge blanking circuit chops off the sensed voltage spike at initial internal MOSFET on state. The PWM duty cycle is determined by the current sense input voltage and the EA output voltage.

### Gate Driver

The internal power MOSFET in OB2235x is driven by a dedicated gate driver for power switch control. Too weak the gate drive strength results in higher conduction and switch loss of MOSFET while too strong gate drive compromises EMI.

A good tradeoff is achieved through the built-in totem pole gate design with right output strength control.

### Protection Control

Good power supply system reliability is achieved with its rich protection features including cycle-by-cycle current limiting, Output short circuit protection, on-chip Over Temperature Protection (OTP), VDD Over Voltage Protection (OVP), Over Loading Protection(OLP) and VDD Under Voltage Lockout Protection (UVLO).



**PACKAGE MECHANICAL DATA**  
**DIP8 PACKAGE OUTLINE DIMENSIONS**

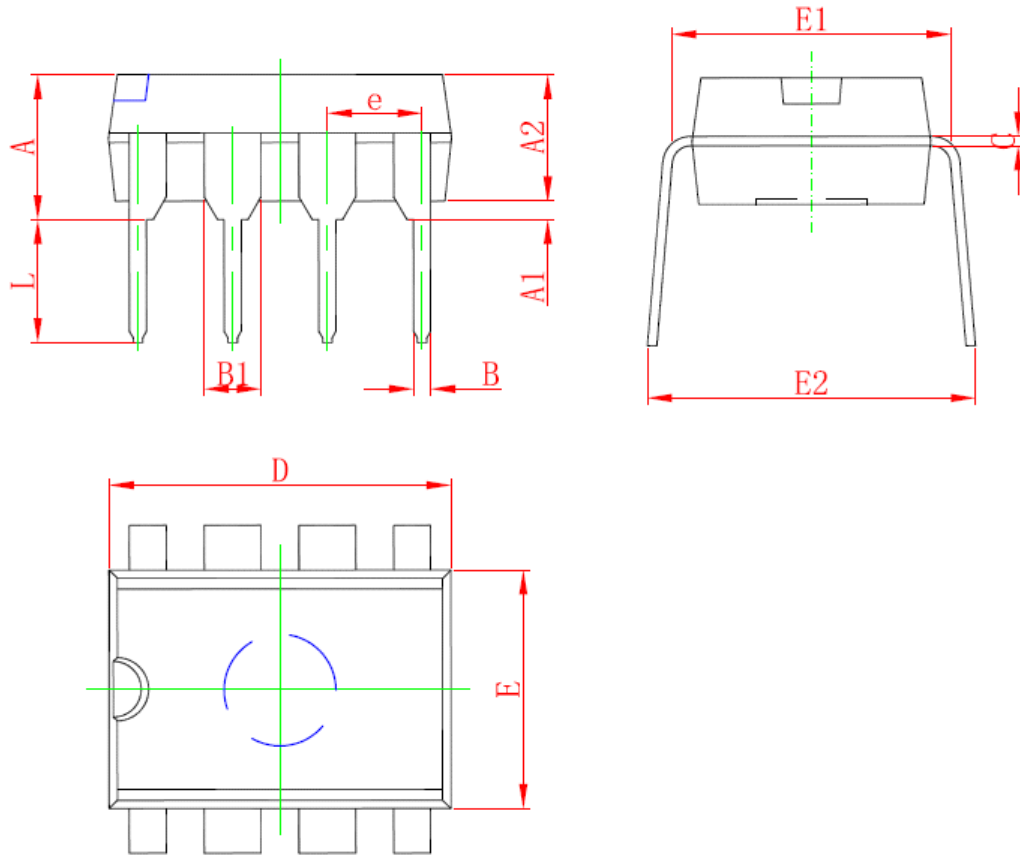

Symbol	Dimensions In Millimeters		Dimensions In Inches	
	Min	Max	Min	Max
A	3.710	5.334	0.146	0.210
A1	0.381		0.015	
A2	2.921	4.953	0.115	0.195
B	0.350	0.650	0.014	0.026
B1	1.524 (BSC)		0.06 (BSC)	
C	0.200	0.360	0.008	0.014
D	9.000	10.160	0.354	0.400
E	6.096	7.112	0.240	0.280
E1	7.320	8.255	0.288	0.325
e	2.540 (BSC)		0.1 (BSC)	
L	2.921	3.810	0.115	0.150
E2	7.620	10.920	0.300	0.430

**DIP7 PACKAGE OUTLINE DIMENSIONS**

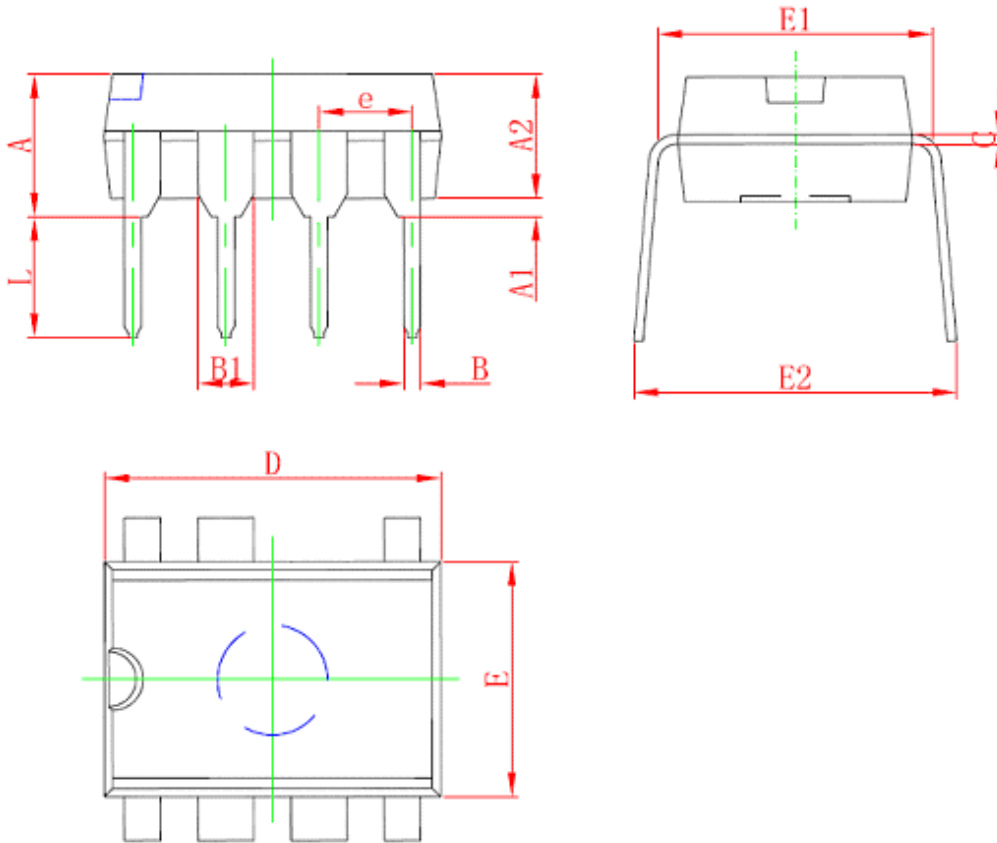

Symbol	Dimensions In Millimeters		Dimensions In Inches	
	Min	Max	Min	Max
A	3.710	5.334	0.146	0.210
A1	0.381		0.015	
A2	2.921	4.953	0.115	0.195
B	0.350	0.650	0.014	0.026
B1	1.524 (BSC)		0.06 (BSC)	
C	0.200	0.360	0.008	0.014
D	9.000	10.160	0.354	0.400
E	6.096	7.112	0.240	0.280
E1	7.320	8.255	0.288	0.325
e	2.540 (BSC)		0.1 (BSC)	
L	2.921	3.810	0.115	0.150
E2	7.620	10.920	0.300	0.430

**SOP8 PACKAGE OUTLINE DIMENSIONS**

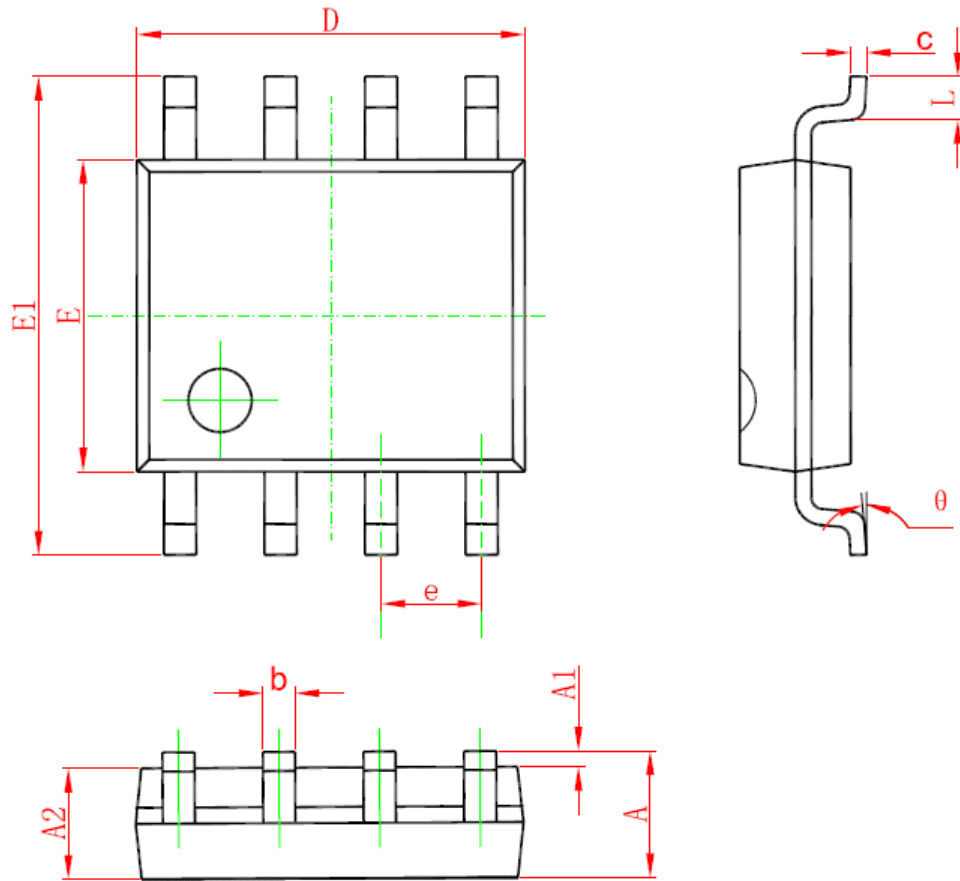

Symbol	Dimensions In Millimeters		Dimensions In Inches	
	Min	Max	Min	Min
A	1.350	1.750	0.053	0.069
A1	0.050	0.250	0.002	0.010
A2	1.250	1.650	0.049	0.065
b	0.310	0.510	0.012	0.020
c	0.170	0.250	0.006	0.010
D	4.700	5.150	0.185	0.203
E	3.800	4.000	0.150	0.157
E1	5.800	6.200	0.228	0.244
e	1.270 (BSC)		0.05 (BSC)	
L	0.400	1.270	0.016	0.050
θ	0°	8°	0°	8°

## **IMPORTANT NOTICE**

### **RIGHT TO MAKE CHANGES**

On-Bright Electronics Corp. reserves the right to make corrections, modifications, enhancements, improvements and other changes to its products and services at any time and to discontinue any product or service without notice. Customers should obtain the latest relevant information before placing orders and should verify that such information is current and complete.

### **WARRANTY INFORMATION**

On-Bright Electronics Corp. warrants performance of its hardware products to the specifications applicable at the time of sale in accordance with its standard warranty. Testing and other quality control techniques are used to the extent it deems necessary to support this warranty. Except where mandated by government requirements, testing of all parameters of each product is not necessarily performed. On-Bright Electronics Corp. assumes no liability for application assistance or customer product design. Customers are responsible for their products and applications using On-Bright's components, data sheet and application notes. To minimize the risks associated with customer products and applications, customers should provide adequate design and operating safeguards.

### **LIFE SUPPORT**

On-Bright Electronics Corp.'s products are not designed to be used as components in devices intended to support or sustain human life. On-Bright Electronics Corp. will not be held liable for any damages or claims resulting from the use of its products in medical applications.

### **MILITARY**

On-Bright Electronics Corp.'s products are not designed for use in military applications. On-Bright Electronics Corp. will not be held liable for any damages or claims resulting from the use of its products in military applications.