

GENERAL DESCRIPTION

OB3398 is a primary side regulation off-line LED lighting controller which can achieve accurate LED current. It significantly simplifies LED lighting system design by eliminating the secondary side feedback circuitry. Proprietary Constant Voltage (CV) and Constant Current (CC) control is integrated as shown in the figure below.

The LED current (CC control) can be adjusted externally by the resistor R_s at CS pin.

OB3398 offers comprehensive protection coverage with auto-recovery features including Cycle-by-Cycle current limiting, VDD clamp and UVLO. Excellent EMI performance is achieved with On-Bright proprietary frequency shuffling technique.

OB3398 is offered in SOT23-5 package.

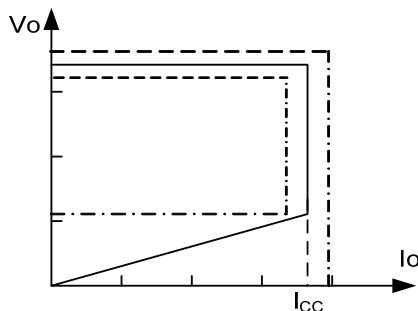

Fig.1. Typical CC/CV Curve

FEATURES

- High Precise Constant Current Regulation at Universal AC input
- Primary-side Sensing and Regulation Without TL431 and Opto-coupler
- Floating PSR control scheme with two transformer windings
- Adjustable Constant Current and Output Power Setting
- Built-in Primary winding inductance compensation
- Built-in Leading Edge Blanking (LEB)
- Cycle-by-Cycle Current Limiting
- VDD Under Voltage Lockout with Hysteresis (UVLO)
- Over temperature protection (OTP)
- VDD Clamp

APPLICATIONS

Low Power AC/DC offline SMPS for

- LED applications

TYPICAL APPLICATION

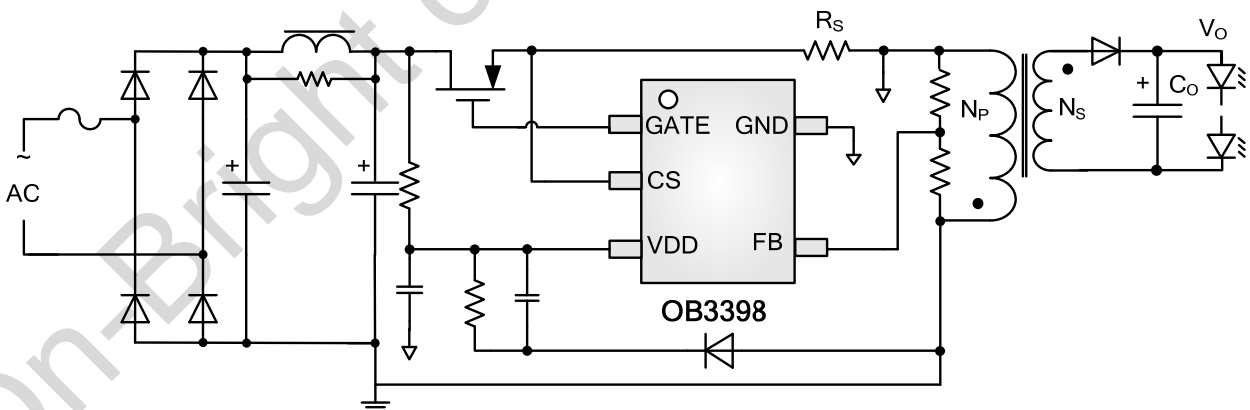

GENERAL INFORMATION

Pin Configuration

SOT23-5.

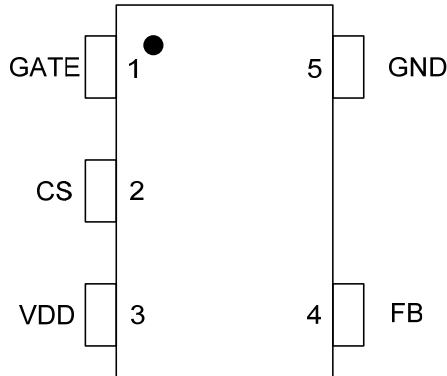

Absolute Maximum Ratings

Parameter	Value
Gate Voltage	-0.3 to 25V
VDD Voltage	-0.3 to V_{DD_clamp}
CS Input Voltage	-0.3 to 7V
FB Input Voltage	-0.3 to 7V
Min/Max Operating Junction Temperature T_J	-40 to 150 °C
Operating Temperature T_A Ambient	-40 to 85 °C
Min/Max Storage Temperature T_{stg}	-55 to 150 °C
Lead Temperature (Soldering, 10secs)	260 °C

Note: Stresses beyond those listed under “absolute maximum ratings” may cause permanent damage to the device. These are stress ratings only, functional operation of the device at these or any other conditions beyond those indicated under “recommended operating conditions” is not implied. Exposure to absolute maximum-rated conditions for extended periods may affect device reliability.

Ordering Information

Part Number	Description
OB3398MP	SOT23-5, Pb-free,T&R

Package Dissipation Rating

Package	R θ JA (°C/W)
SOT23-5	200

Recommended Operating Condition

Symbol	Parameter	Range
VDD	VDD Supply Voltage	12 to 25 V

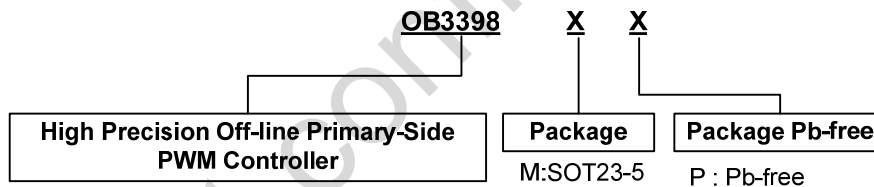

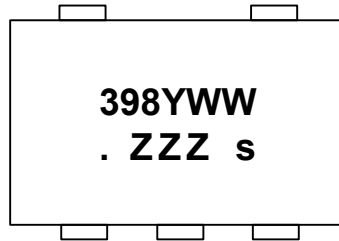
Marking Information

Y:Year Code
 WW:Week Code(01-52)
 ZZZ: Lot code
 s: Internal code

TERMINAL ASSIGNMENTS

Pin Num	Pin Name	I/O	Description
1	GATE	O	Gate driver output
2	CS	I	Current sense input.
3	VDD	P	Power Supply
4	FB	I	Connected to resistor divider from primary winding or auxiliary winding to reflect output voltage.
5	GND	P	Ground

BLOCK DIAGRAM

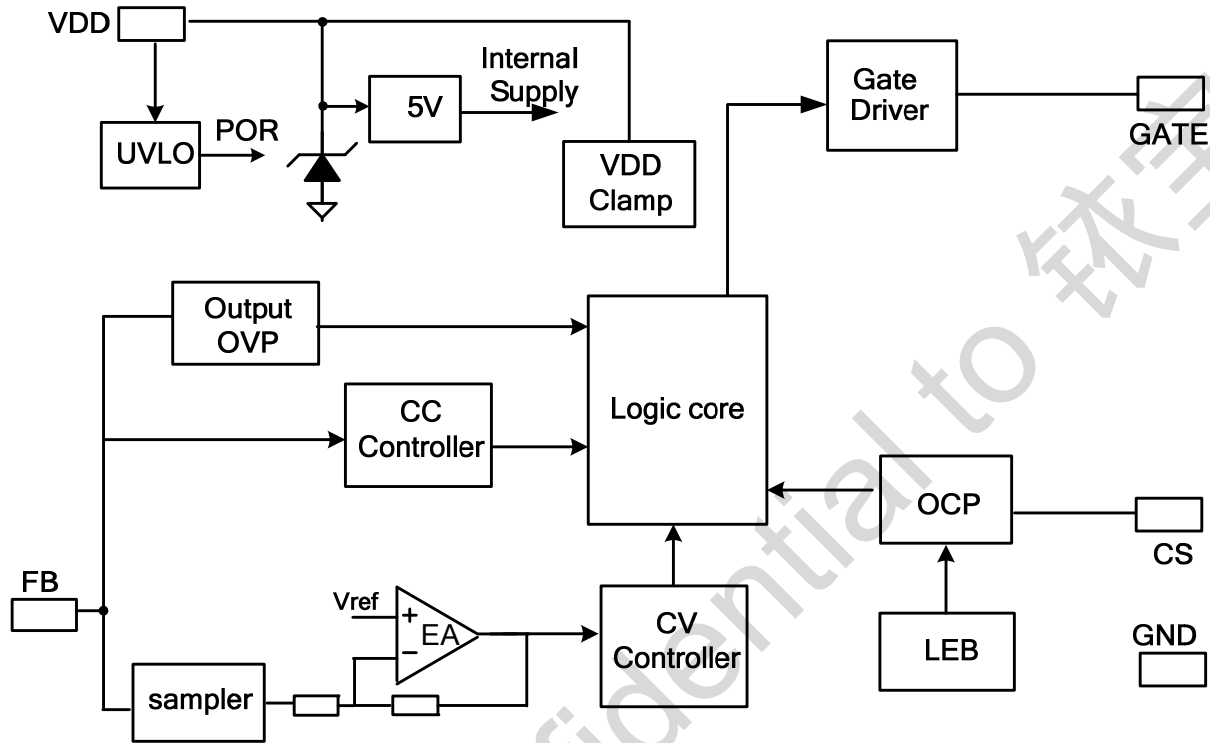

ELECTRICAL CHARACTERISTICS

(TA = 25°C, VDD=16V, if not otherwise noted)

Symbol	Parameter	Test Conditions	Min	Typ.	Max	Unit
Supply Voltage (VDD) Section						
I _{startup}	Startup Current	VDD=UVLO_OFF-1V		4	20	uA
I _{DD op}	Operation Current	Operation supply current FB=1V, CS=0V, VDD= 20V	-	0.45	1	mA
UVLO(ON)	VDD Under Voltage Lockout Enter	VDD falling	7.3	8.3	9.3	V
UVLO(OFF)	VDD Under Voltage Lockout Exit	VDD rising	15.5	16.5	17.5	V
V _{DD_clamp}	Maximum VDD operation voltage	I _{DD} =20mA		25		V
Current Sense Input Section						
TLEB	LEB time			500		ns
V _{th_oc}	Over current threshold		492	500	508	mV
T _{d_oc}	OCP Propagation delay			100		ns
Frequency Section						
Freq_Max ^{Note}	IC Maximum frequency		103			KHz
T _{off_min}	Minimum Toff			4.0		us
F _{min}	Minimum frequency			103		Hz
Δf/Freq	Frequency shuffling range			±7		%
Error Amplifier section						
V _{ref_EA}	Reference voltage for EA		1.14	1.2	1.26	V
Gain	DC gain of EA			40		
V _{th_OVP}	Load OVP threshold voltage			1.4		V
Gate Driver Section						
V _{OL}	Output low level @ VDD=14V, I _o =5mA				1	V
V _{OH}	Output high level @ VDD=14V, I _o =20mA		6			V
V _{clamping}	Output clamp voltage			10		V
T _r	Output rising time 1V~ 9V@ CL=500pF			95		ns
T _f	Output falling time 9V~1V@ CL=500pF			50		ns
On chip Over temperature Section						
T _{otp}	Over temperature protection trigger point			135		°C
T _{otp_rec}	Over temperature protection recovery point			120		°C

Note:

1. Freq_Max indicates IC internal maximum clock frequency. In system application, the maximum operation frequency of 103KHz nominal occurs at maximum output power or the transition point from CV to CC.

CHARACTERIZATION PLOTS

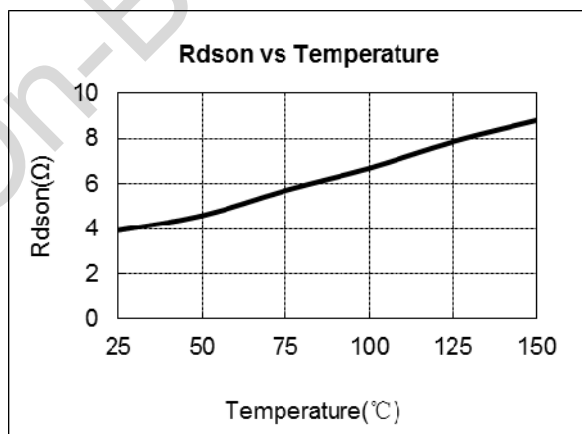
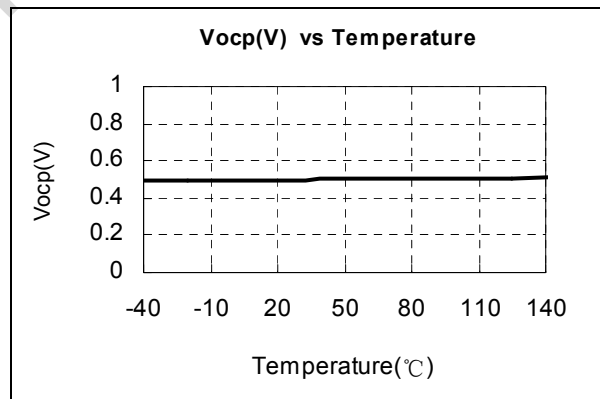
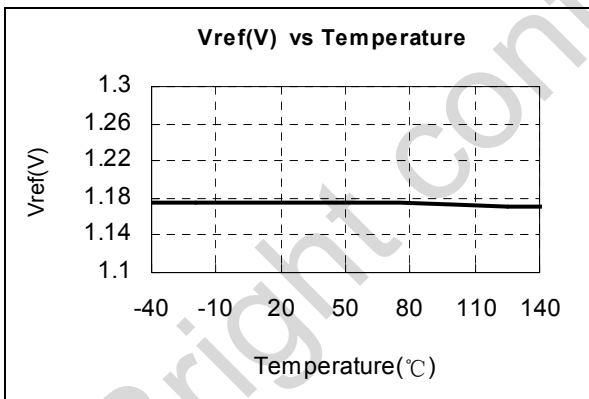
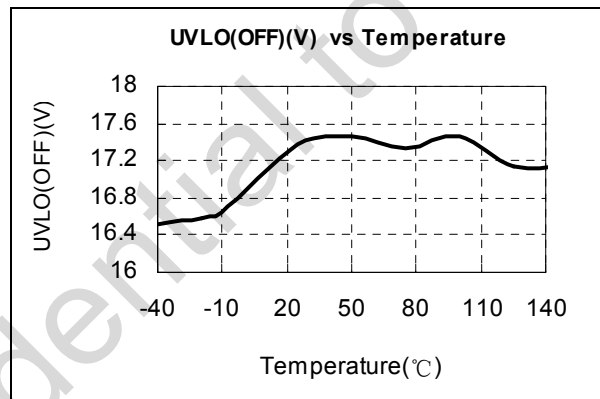
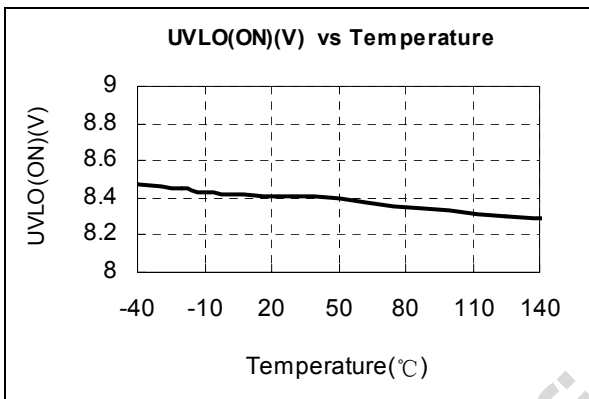
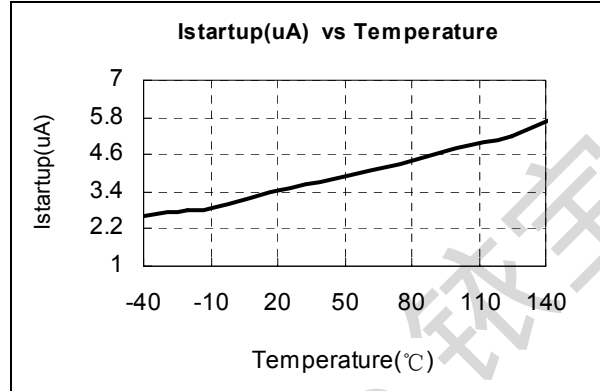
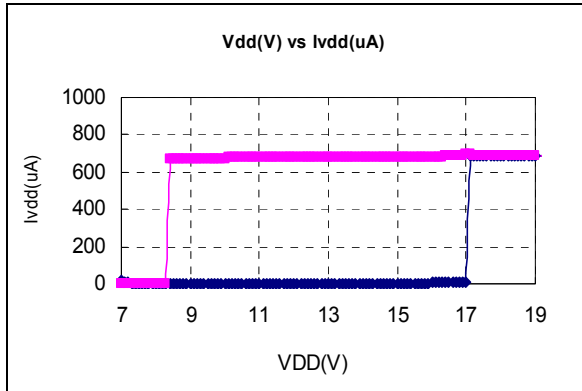

OPERATION DESCRIPTION

OB3398 is a cost effective PWM controller optimized for off-line LED lighting applications. Based on floating flyback converter topology working in DCM mode, it operates in primary side sensing and regulation, thus opto-coupler and TL431 are not required. Proprietary built-in CC control can achieve high precision LED current meeting LED lighting application requirements.

- **Startup Current and Start up Control**

Startup current of OB3398 is designed to be very low so that VDD could be charged up above UVLO threshold and starts up quickly. A large value startup resistor can therefore be used to minimize the power loss in application.

- **Operating Current**

The Operating current of OB3398 is as low as 0.45mA(Typ.). Typical good efficiency is achieved with the low operating current together with 'Multi-mode' control features.

- **Principle of CC Operation**

To support OB3398 proprietary CC control, system needs to be designed in DCM mode for flyback system (Refer to Typical Application Diagram on page1). The LED output current I_{LED} is given by:

$$I_{LED} = \frac{1}{2} L_p \cdot F_{SW} \cdot I_{PK}^2 \cdot \eta / V_O \quad (1)$$

Where L_p indicates the inductance of primary winding, I_{pk} is the peak current of primary winding.

Refer to the equation 1, the change of the primary winding inductance results in the change of the constant output current. To compensate the change from variations of primary winding inductance, the switching frequency is locked by an internal loop such that the switching frequency is

$$F_{SW} = \frac{1}{2T_{Demag}} \quad (2)$$

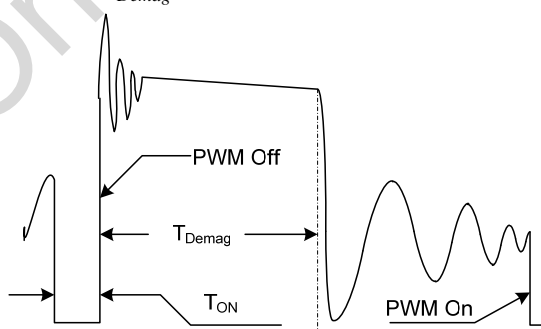

Figure.1 Primary voltage waveform

Since T_{Demag} is inversely proportional to the inductance, as a result, the product L_p and f_{sw} is constant, thus output current will not change as primary winding inductance changes. Up to $\pm 7\%$ variation of the primary winding inductance can be compensated.

The output LED current is

$$I_{LED} = \frac{1}{4} \cdot N \cdot \frac{V_{th-oc}}{R_s} \quad (3)$$

Where N is the ratio of transformer between primary winding and secondary winding.

- **Adjustable CC point and Output Power**

In OB3398, the CC point and maximum output power can be externally adjusted by external current sense resistor R_s at CS pin as illustrated in Typical Application Diagram. The output power is adjusted through CC point change. The larger R_s , the smaller CC point is, and the smaller output power becomes, and vice versa as shown in Fig.2.

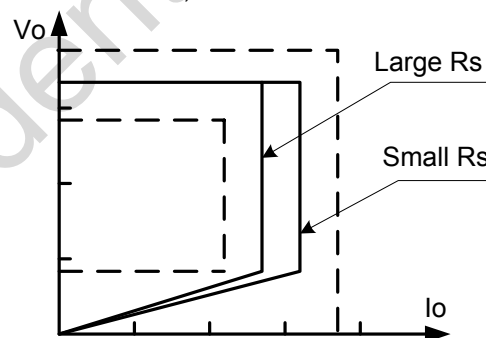

Figure.2 Adjustable output power by changing R_s

- **Operation switching frequency**

The switching frequency of OB3398 is adaptively controlled according to the load conditions and the operation modes. No external frequency setting components are required. The operation switching frequency at maximum output power is set to 103K Hz internally.

For flyback operating in DCM, The maximum output power is given by

$$P_{Omax} = \frac{1}{2} \eta L_p F_{SW} I_{pk}^2 \quad (4)$$

Where L_p indicate the inductance of primary winding and I_{pk} is the peak current of primary winding.

The principle of CC operation sets the product L_p and f_{sw} to be a constant, thus the maximum output power and constant current in CC mode will not change as primary winding inductance changes. Up to $\pm 7\%$ variation of the primary winding inductance can be compensated.

- **CV / OVP Mode**

When LED string is open, an output voltage condition is monitored independently by the voltage at FB pin. During normal operation, the voltage at FB pin is regulated at 1.2V (typ.), with dummy load over P_{min}.

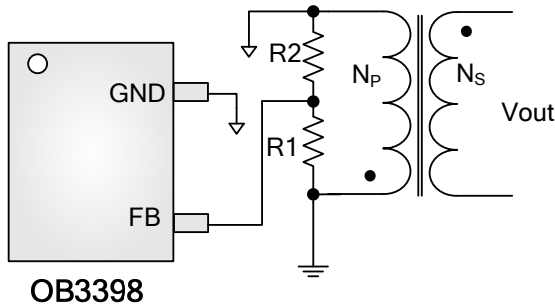

Figure.3 FB Section Circuit

$$V_{OUT} = \frac{N_s}{N_p} \times \frac{R1 + R2}{R2} \times V_{ref_CV}$$

R1 —Resistor connected between the FB pin and the input capacitor GND, the value suggested is 330Kohms~1Mohms

R2 —Resistor connected between the FB pin and the GND pin of IC, the value suggested is 5Kohms~15Kohms

$$P_{min} = \frac{1}{2} \times \left(\frac{V_{th_oc}}{R_{CS}} \right)^2 F_{min} L_{primary}$$

V_{th_oc} — Over current protection threshold voltage

F_{min} — Minimum switching frequency, which is 103Hz (typ.)

If the dummy load is less than P_{min}, the output voltage rises up. If the voltage at FB pin exceeds a threshold of approximately 1.4V (typical), the over-voltage protection function is activated and the switching is turned off immediately.

$$V_{OVP} = \frac{N_s}{N_p} \times \frac{R1 + R2}{R2} \times V_{vth_OVP}$$

- **CC Line Regulation**

Adjust the R1 for better CC line regulation, while driving different type MOSFET. The larger MOSFET, the smaller R1 needed. R1 allow the change from 330K to 1M ohms to cover all the applications. If the resistance is too large, it causes the interference due to the floating ground, too small resistance results the efficiency decreased at HV AC line.

- **Frequency shuffling for EMI improvement**

The frequency shuffling (switching frequency modulation) is implemented in OB3398. The oscillation frequency is modulated so that the tone energy is spread out. The spread spectrum minimizes the conduction band EMI and therefore eases the system design.

- **Current Sensing and Leading Edge Blanking**

Cycle-by-Cycle current limiting is offered in OB3398. The switch current is detected by a sense resistor into the CS pin. An internal leading edge blanking circuit chops off the sensed voltage spike at initial power MOSFET on state so that the external RC filtering on sense input is no longer needed. The PWM duty cycle is determined by the current sense input voltage and the EA output voltage.

- **Protection Control**

Good power supply system reliability is achieved with its rich protection features including Cycle-by-Cycle current limiting (OCP), VDD clamp, on-chip OTP, and Under Voltage Lockout on VDD (UVLO).

VDD is supplied by transformer primary winding output. The output of OB3398 is shut down when VDD drops below UVLO (ON) limit and the power converter enters power on start-up sequence thereafter.

PACKAGE MECHANICAL DATA

5-Pin Plastic SOT (SOT23-5)

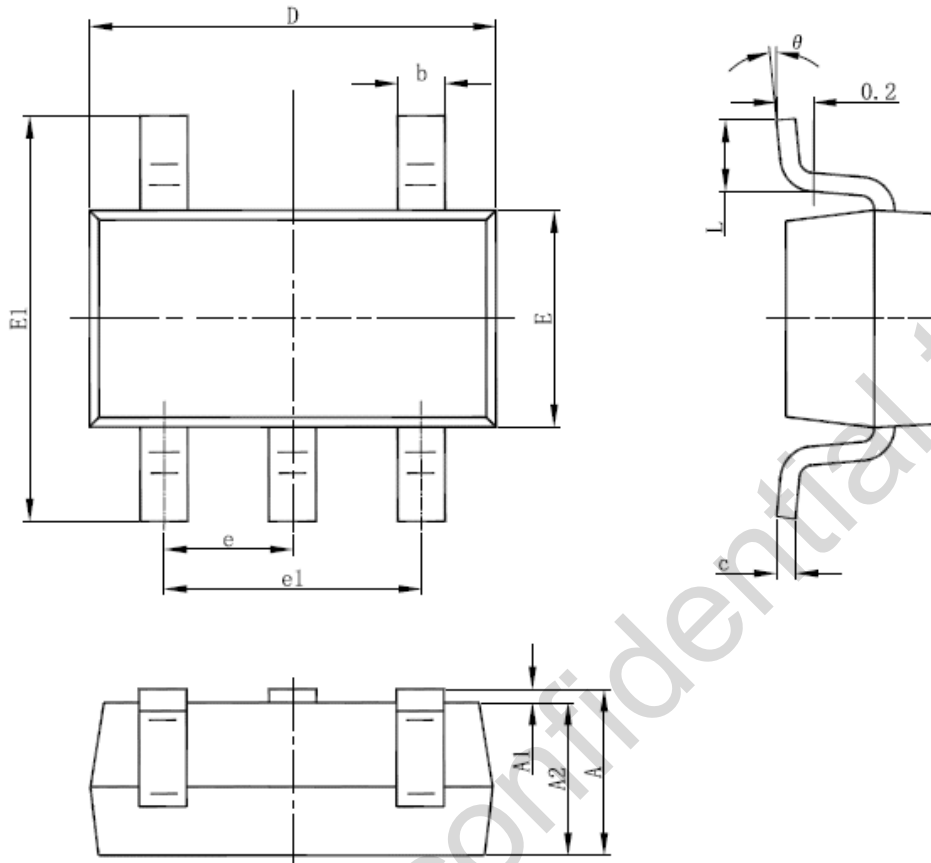

Symbol	Dimensions In Millimeters		Dimensions In Inches	
	Min	Max	Min	Max
A	1.000	1.450	0.039	0.057
A1	0.000	0.150	0.000	0.006
A2	0.900	1.300	0.035	0.051
b	0.300	0.500	0.012	0.020
c	0.080	0.220	0.003	0.009
D	2.800	3.020	0.110	0.119
E	1.500	1.726	0.059	0.068
E1	2.600	3.000	0.102	0.118
e	0.950 (BSC)		0.037 (BSC)	
e1	1.800	2.000	0.071	0.079
L	0.300	0.600	0.012	0.024
θ	0°	8°	0°	8°

IMPORTANT NOTICE

RIGHT TO MAKE CHANGES

On-Bright Electronics Corp. reserves the right to make corrections, modifications, enhancements, improvements and other changes to its products and services at any time and to discontinue any product or service without notice. Customers should obtain the latest relevant information before placing orders and should verify that such information is current and complete.

WARRANTY INFORMATION

On-Bright Electronics Corp. warrants performance of its hardware products to the specifications applicable at the time of sale in accordance with its standard warranty. Testing and other quality control techniques are used to the extent it deems necessary to support this warranty. Except where mandated by government requirements, testing of all parameters of each product is not necessarily performed.

On-Bright Electronics Corp. assumes no liability for application assistance or customer product design. Customers are responsible for their products and applications using On-Bright's components, data sheet and application notes. To minimize the risks associated with customer products and applications, customers should provide adequate design and operating safeguards.

LIFE SUPPORT

On-Bright Electronics Corp.'s products are not designed to be used as components in devices intended to support or sustain human life. On-bright Electronics Corp. will not be held liable for any damages or claims resulting from the use of its products in medical applications.

MILITARY

On-Bright Electronics Corp.'s products are not designed for use in military applications. On-Bright Electronics Corp. will not be held liable for any damages or claims resulting from the use of its products in military applications.