

GENERAL DESCRIPTION

The OB3663 is a high performance single stage AC/DC fly-back controller for dimmable LED luminaires. The OB3663 integrates advanced digital processing core to eliminate visible flicker.

OB3663 offers fast startup feature, constant on-time control for power factor correction (PFC), zero current detector (ZCD) to ensure transition mode (TM) operation, and accurate current regulation.

OB3663 offers comprehensive protection coverage including VDD under voltage lockout (UVLO), VDD over voltage protection, load voltage over voltage protection, cycle-by-cycle current limiting, over temperature protection, LED string open/short protection, driver output clamping for external power MOSFET protection, current sense resistor short protection, and transformer saturation protection.

OB3663 is offered in SOP14 package (OB3663CP) and SSOP10 package (OB3663LP).

FEATURES

- Primary-Side Control with Single Stage PFC Topology
- No visible flicker
- No bleeder design
- Total harmonic distortion <20% with PF>0.9
- Fast startup time (<0.5s without dimmer)
- Transition Mode (TM) operation to achieve high efficiency
- High current accuracy
- Source driving operation mode
- Cycle-by-Cycle Current Limiting (OCP)
- VDD Over Voltage Protection
- Output Over Voltage Protection
- Over-Temperature Protection
- VDD Under Voltage Lockout (UVLO)
- LED string open protection
- LED string short protection
- Current sense resistor short/open protection
- Transformer saturation protection

APPLICATIONS

- Dimmable LED lighting

TYPICAL APPLICATION

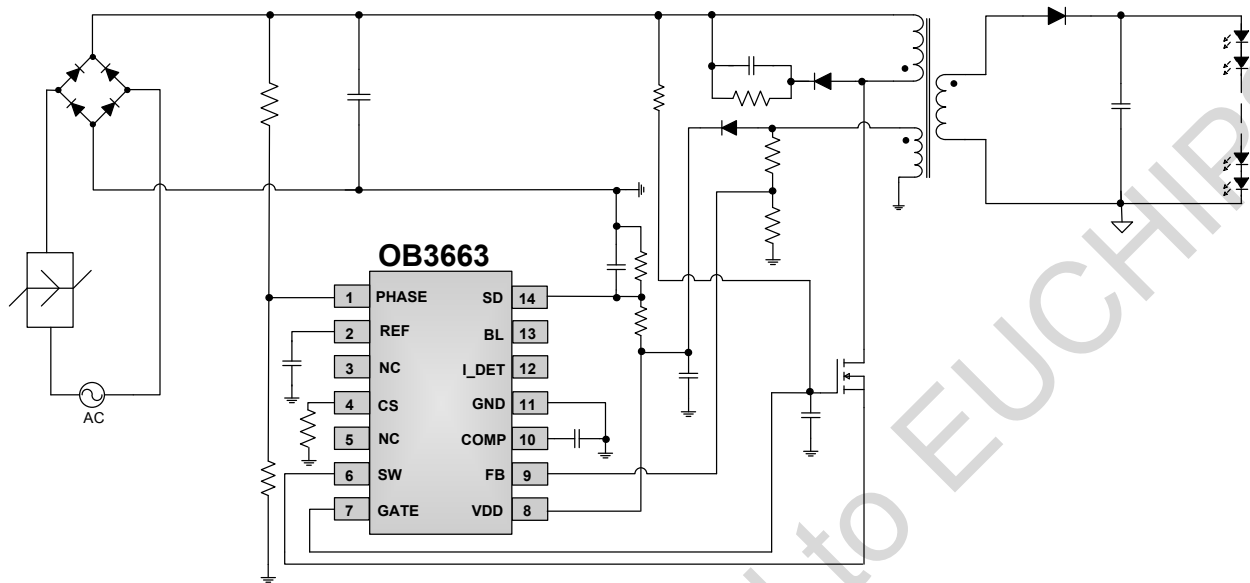

Figure1: OB3663CP Typical Application Schematic

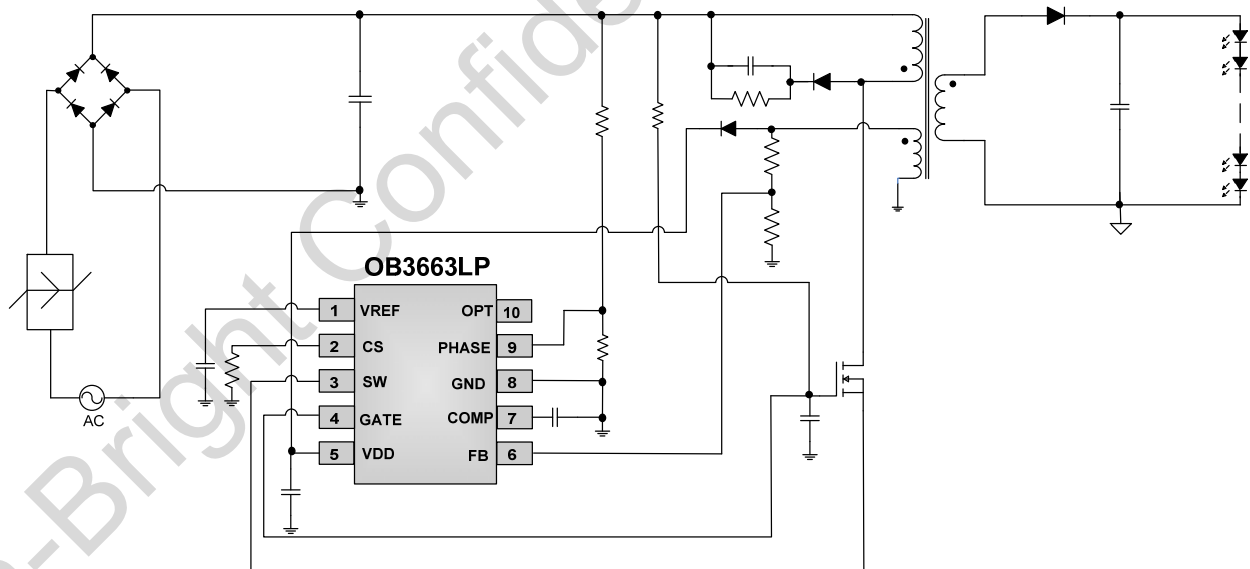

Figure2: OB3663LP Typical Application Schematic

GENERAL INFORMATION
Package Dissipation Rating

Package	R θ JA (°C/W)
SOP14	90
SSOP10	138

Ordering Information

Part Number	Description
OB3663CP	SOP14, Pb free in Tube
OB3663CPA	SOP14, Pb free in T&R
OB3663LP	SSOP10, Pb free in Tube
OB3663LPA	SSOP10, Pb free in T&R

Note1: All Devices are offered in Pb-free Package if not otherwise noted.

Absolute Maximum Ratings

Parameter	Value
VDD Input Voltage to GND	-0.3V to 24V
GATE to GND	-0.7V to 24V
SW to GND	-0.7V to 20V
FB to GND	-0.7V to 7V
COMP, REF and CS to GND	-0.7V to 7V
PHASE, I_DET, BL, SD, PD, OPT	-0.7V to 5V
Operating Ambient Temp. T _A	-40 ~85°C
Operating Junction Temp. T _J	-40 ~150°C
Min/Max Storage Temp. T _{stg}	-55 ~150°C
Lead Temp. (10 Sec)	260 °C

Note2: Stresses beyond those listed under "absolute maximum ratings" may cause permanent damage to the device. These are stress ratings only, functional operation of the device at these or any other conditions beyond those indicated under "recommended operating conditions" is not implied. Exposure to absolute maximum-rated conditions for extended periods may affect device reliability.

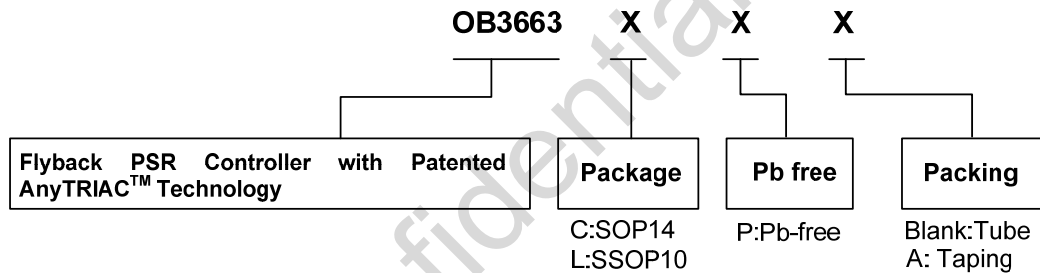
Marking Information

Y: Year Code
 WW: Week Code (01-52)
 ZZZ: Lot Code
 C: SOP14 Package
 P: Pb-free Package
 S: Internal Code(Optional)

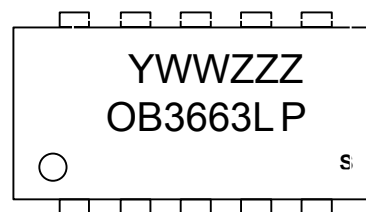

Y: Year Code
 WW: Week Code(01-52)
 ZZZ: Lot Code
 L: SSOP10 Package
 P: Pb-free Package
 S: Internal Code(Optional)

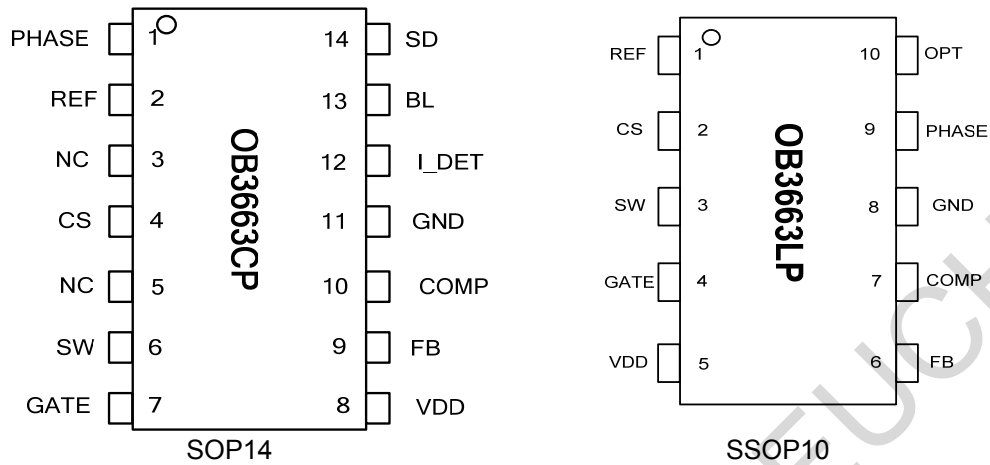
Pin Configuration for OB3663

Terminal Assignment for OB3663CP

Number	Pin Name	I/O	Pin Function
1	PHASE	I/O	Phase detect pin. The line voltage is connected to this pin through a resistor divider, to detect when the TRIAC is on and off.
2	REF	I/O	Internal LDO output. Connected a 1uF capacitor to this pin.
3	NC		No Connection
4	CS	I/O	Current sense input pin.
5	NC		No Connection
6	SW	I/O	Drain of internal MOSFET.
7	GATE	I/O	The gate voltage clamp of external power MOSFET.
8	VDD	P	Power supply voltage pin.
9	FB	I/O	Feedback pin.
10	COMP	I/O	Loop compensation pin. Connect to a compensation network to stabilize the LED driver and achieve a constant LED driver current.
11	GND	P	Ground.
12	I_DET	I/O	Line current detect input pin.
13	BL	I/O	BL optional pin
14	SD	I/O	Shut down pin

Terminal Assignment OB3663LP

Number	Pin Name	I/O	Pin Function
1	REF	I/O	Internal LDO output. Connected a 10uF capacitor to this pin.
2	CS	I/O	Current sense input pin.
3	SW	I/O	Drain of internal MOSFET.
4	GATE	I/O	The gate voltage clamp of external power MOSFET.
5	VDD	P	Power supply voltage pin.
6	FB	I/O	Feedback pin.
7	COMP	I/O	Loop compensation pin. Connect to a compensation network to stabilize the LED driver and achieve a constant LED driver current.
8	GND	P	Ground.
9	PHASE	I/O	Phase detect pin.
10	OPT	I/O	Optional function output for applications

Functional Block Diagram

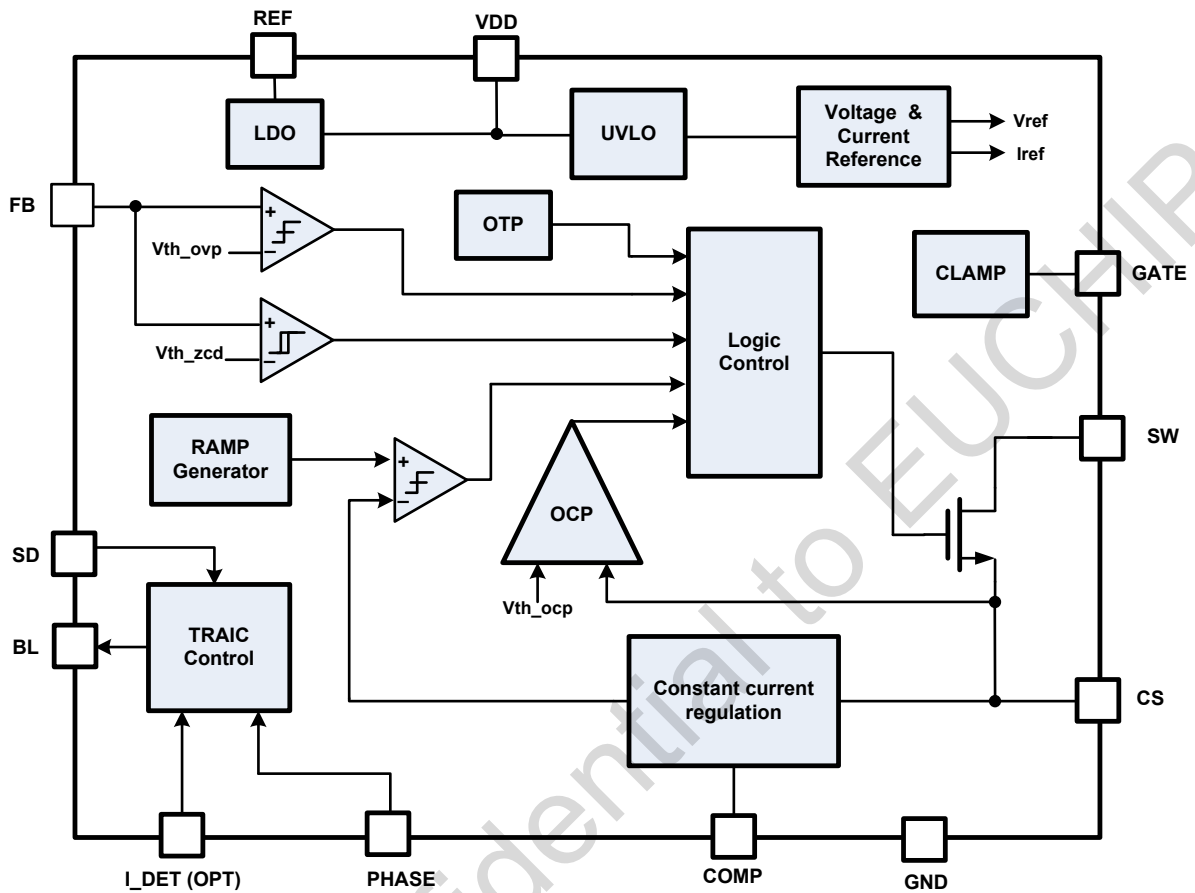

Figure2: OB3663 Functional Block Diagram

Electrical Characteristics

 VDD=16V, T_A=25°C, if not otherwise noted.

Symbol	Parameter	Test Conditions	Min	Typ.	Max	Unit
Supply Voltage Section						
I _{static}	Static Current	VDD=16V		6		mA
UVLO(ON)	Under Voltage Lockout Enter		5.5	6.0	6.5	V
UVLO(OFF)	Under Voltage Lockout Exit		12.3	13	13.7	V
VDD_HOLD	VDD Hold Voltage			7.5		V
VDD_OVP	VDD Over Voltage Threshold		21.3	22.5	23.7	V
VREF	REF pin output voltage			3.5		V
Current Sense Section						
TLEB	LEB time			300		ns
Vth_oc	Over Current Threshold		0.95	1.00	1.05	V
Vth_oc_short	OCP threshold @VFB < 0.45V		0.40	0.50	0.60	V
Td_oc	OCP Propagation Delay			40		ns
FB Section						
Vovp	FB over voltage protection		3.395	3.500	3.605	V
Tfb_leb	FB blanking time		1.5	2.0	2.5	us
Vth_fb_low	FB threshold voltage for 1/2 OCP			0.45		V
Gm Amplifier Section						
Vref_ea	EA Reference Voltage	Full brightness	0.195	0.200	0.205	V
Gm	EA Transconductance Gain			100		μA/V
PWM Control Section						
Toff_max	Re-start timer period			25		us
Ton_max	Maximum on time			25		us
Fmax	Maximum frequency			500		KHz
Temperature Section						
OTP	OTP trigger threshold			150		°C
Hysteresis				20		°C
Gate Section						
Vclamp_startup	Gate clamp at startup			22		V
Vclamp_op	Gate clamp at operation			15.7		V
Iclamp	Gate clamp current @ operation	Vgate=Vclamp_op+2V		4		mA
SW Section						
Rds_on	On-chip MOSFET on resistor			0.4		Ω
TRIAC Section						
Vth_phase	Phase detect TRIAC on threshold voltage			3.42		V
	Phase detect TRIAC off threshold voltage			2.05		V
FBL	Frequency of BL output			110		KHz
DBL	Duty cycle of BL output		0		100	%
Vth_imax	Corresponding Voltage of max holding current			0.46		V
SD Section						
Vth_sd	Threshold voltage of SD pin			1.2		V
Tdet_sd	SD pin detection time			500		ms
Trec_sd	SD pin recovery time			5		s

TYPICAL PERFORMANCE CHART

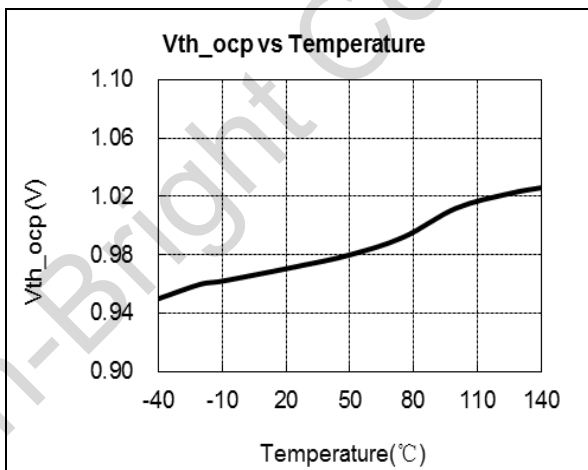
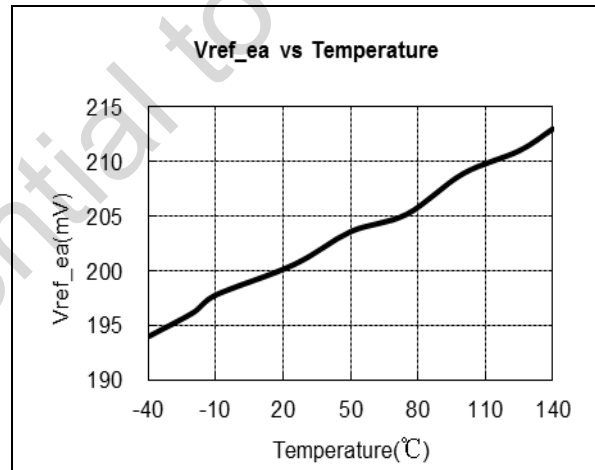
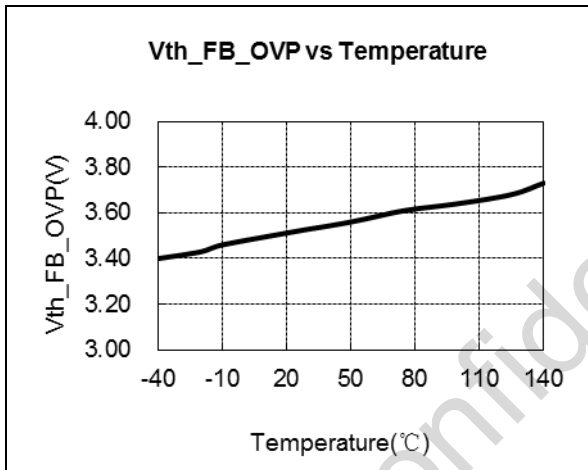
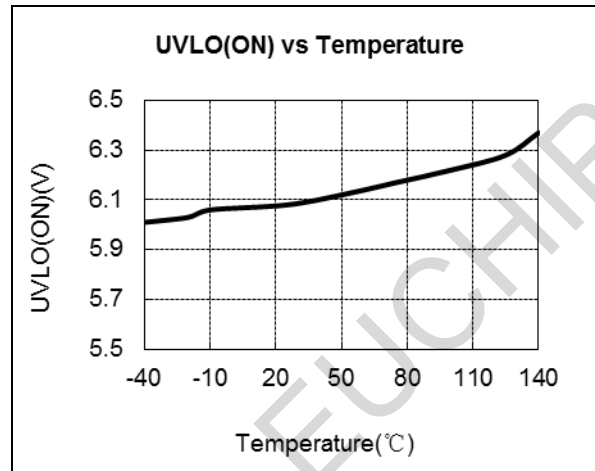
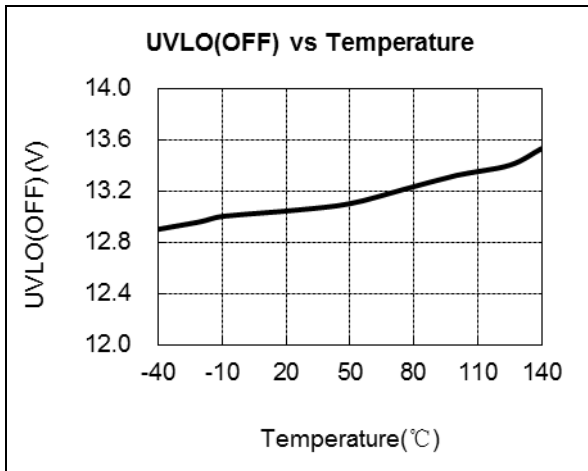

Function Description

General Operation

The OB3663 is a primary-side-control and high power factor flyback PWM controller specialized for dimmable LED lighting application. It operates in primary side sensing and regulation, thus opto-coupler and TL431 are not required. The transition mode control greatly reduces the switch turn-on loss, improves the conversion efficiency. It provides very good power factor.

The OB3663 integrates accurate phase detection and measurement circuits, together with On-Bright's proprietary digital processing architecture to detect the TRIAC dimmer type and the holding current. Based on the information, OB3663 provides wide dimming range (from 1% to 100%), and outputs a reasonable bleeding current. OB3663 is adaptively suitable for a wide range of TRIAC dimmer with good efficiency.

Startup

When system starts up, the GATE pin is charged by the line voltage through a resistor and finally clamped at 22V (typical), the external MOSFET turns on. And the VDD pin is directly charged by line voltage through MOSFET and from SW to internal charge control circuits. This makes the startup very fast. When the VDD voltage exceeds UVLO_OFF threshold voltage (typical 13V), the IC starts to switch and the internal charge control circuit stop charging to VDD, and the VDD is supplied by the AUX winds instead of line voltage. When the VDD drops below the VDD_HOLD threshold voltage (typical 7.5V), the internal charging circuit triggers and charges VDD and holds it at 7.5V. Therefore, output voltage can operate in widely range by this function.

UVLO

An under-voltage lockout with a hysteresis control is provided on VDD. When the voltage at this pin exceeds a threshold of approximately 13V, the IC starts the normal operation. If the voltage at this pin drops below a threshold of approximately 6V, the IC stops switching operation. The IC resumes switching operation when the voltage at pin VDD recovers to a voltage above 13V (typical).

LDO

When the VDD voltage exceeds UVLO_OFF threshold voltage (typical 13V), the IC starts to work, the internal LDO outputs a 3.5V (typical) voltage at REF pin, the voltage is used to power the internal logic circuits. A 1uF capacitor from

REF pin to GND is recommended to be added for decoupling.

LED Constant Current Regulation

OB3663 uses the primary side constant current control method to accurately control the LED current. The LED average current can be approximated as:

$$I_{LED}[mA] = \eta * \frac{N}{2} * \frac{200[mV]}{R_{CS}[\Omega]} * Duty$$

η —The transformer coupling coefficient.

N—Turn ratio of primary side winding to secondary side winding.

Rcs—the sensing resistor connected between CS pin and GND.

Duty—the duty cycle is related to the angle of TRIAC dimmer and can be set by the program.

Current Sensing

OB3663 performs zero current detection (ZCD) through FB pin by monitoring the voltage activity on the auxiliary windings in series with external resistors. This voltage features output voltage. When the stored energy of the fly-back transformer fully release to the output, the voltage at FB pin decreases. When FB pin voltage falls below 0.3V (typical), an internal ZCD comparator is triggered and a new PWM switching cycle is initiated.

Maximum and Minimum On-Time

The minimum on-time of the system is determined by the LEB time (typical 300ns). The IC limits the on-time to a maximum value of approximately 25us (typical).

Output OVP Protection

The output over-voltage condition is monitored independently through the voltage at FB pin. During normal operation, when the voltage at FB pin exceeds a threshold of approximately 3.5V (typical), the over-voltage protection function is activated and the driver is turned off immediately.

VDD OVP Protection

VDD is supplied with auxiliary winding output. When VDD is higher than 22.5V (typical), OVP protection is triggered and driver is shut down, so the device enters power on startup sequence thereafter.

LED String Open Protection

When LED string open happens, the positive plateau of FB voltage rise up due to the auxiliary winding voltage increases. If the voltage at FB pin is higher than a threshold of approximately 3.5V (typical), the over-voltage protection function is activated and the driver is turned off immediately.

LED String Short Protection

When LED string is short, the positive plateau of FB voltage from auxiliary winding falls to near zero. If the voltage at FB pin is lower than a threshold of approximately 0.45V (typical), the threshold of OCP will drop down from 1V (typical) to 0.5V (typical), and COMP pin voltage will increase. When COMP voltage reaches 4.2V (typical), the switching is stopped immediately.

SD Pin Operation (OB3663CP only)

OB3663 monitors the voltage on SD pin. When the OB3663 starts up, if the voltage on SD is

continuously below 1.2V for 500ms, the OB3663 stops switching for 5s, and then starts to monitor the voltage on SD again. The SD pin can provide user flexible protection functions just by monitoring the voltage on SD pin.

OPT Pin Operation (OB3663LP only)

OB3663 offers an OPT(optional function pin) for universal dimming application, the user can define the function by pre-setting in the advanced digital processing units.

Thermal Shutdown

OB3663 provides an on chip thermal shutdown protection. The IC will stop switching when the junction temperature exceeds the thermal shutdown temperature, typically 150 °C, when the temperature is below 130°C, the IC starts to switching again.

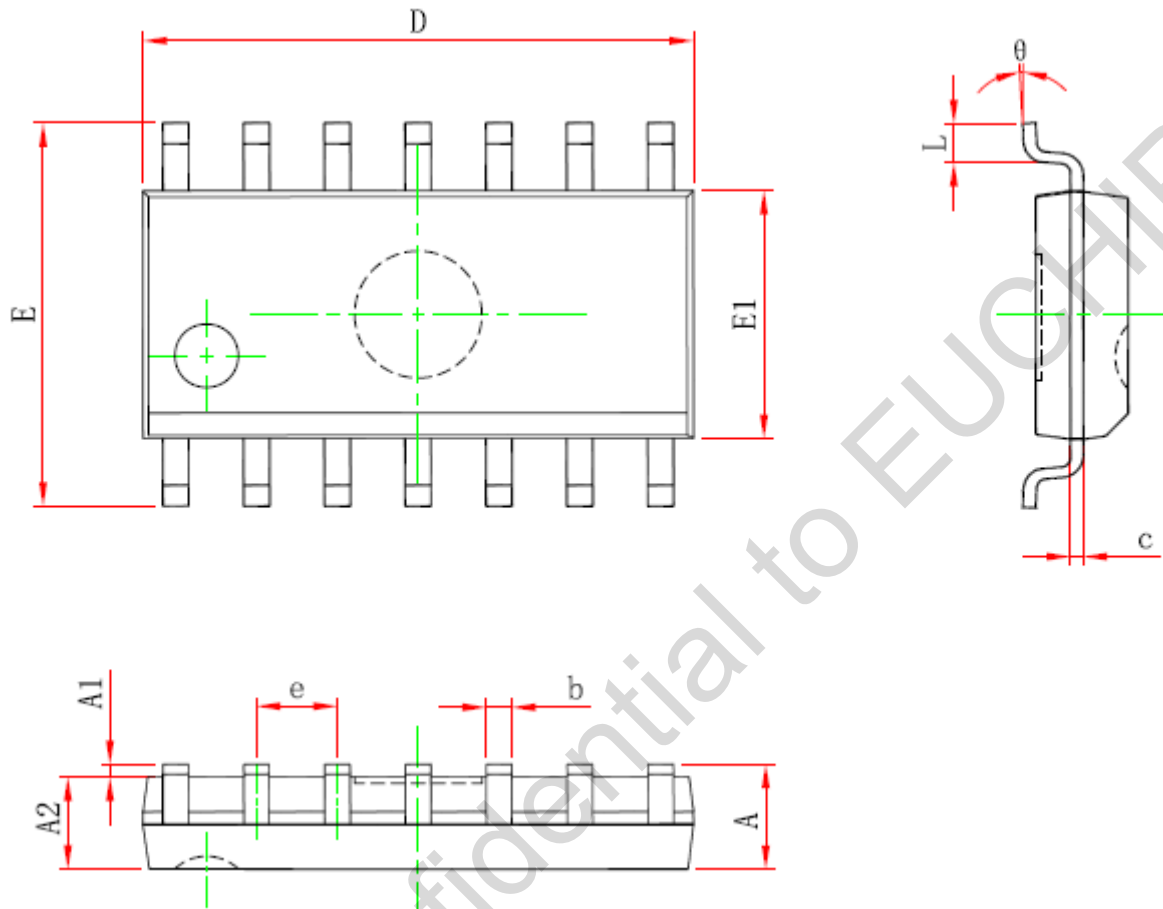
PACKAGE MECHANICAL DATA
SOP14 PACKAGE OUTLINE DIMENSIONS

Symbol	Dimensions In Millimeters		Dimensions In Inches	
	Min	Max	Min	Max
A	-	1.750	-	0.069
A1	0.050	0.250	0.002	0.010
A2	1.250	-	0.049	-
b	0.310	0.510	0.012	0.020
c	0.100	0.260	0.004	0.010
D	8.450	8.850	0.333	0.348
E	5.800	6.200	0.228	0.244
E1	3.700	4.100	0.146	0.161
e	1.270 (BSC)		0.050 (BSC)	
L	0.400	1.270	0.016	0.050
θ	0°	8°	0°	8°

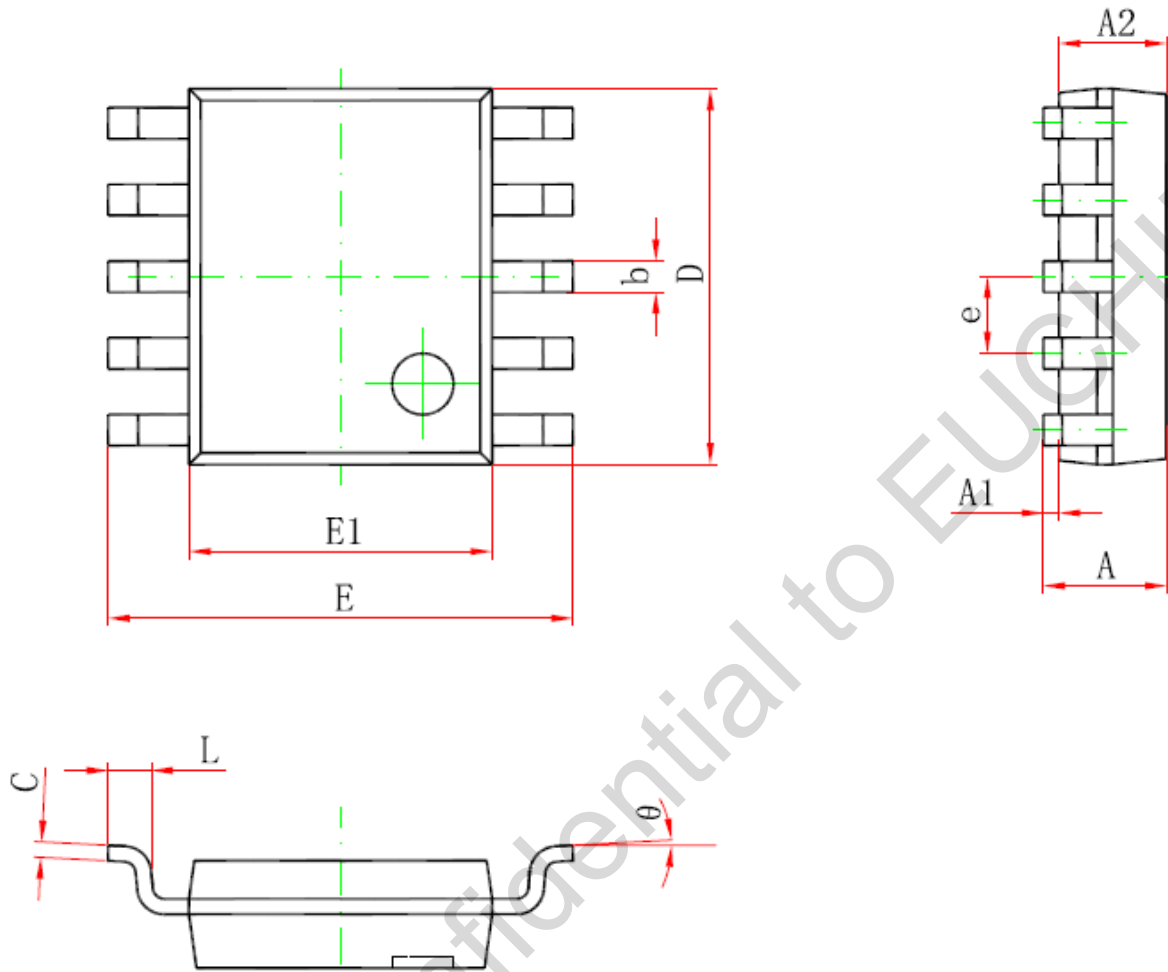
SSOP10 PACKAGE OUTLINE DIMENSIONS

Symbol	Dimensions In Millimeters		Dimensions In Inches	
	Min	Max	Min	Max
A	-	1.750	-	0.069
A1	0.100	0.250	0.004	0.010
A2	1.300	1.550	0.051	0.061
b	0.330	0.510	0.013	0.020
C	0.170	0.260	0.007	0.010
D	4.700	5.100	0.185	0.201
E	5.800	6.200	0.228	0.244
E1	3.700	4.100	0.146	0.161
e	1.000(BSC)		0.039(BSC)	
L	0.400	1.270	0.016	0.050
θ	0°	8°	0°	8°

Important Notice

Right to make changes

On-Bright Electronics Corp. reserves the right to make corrections, modifications, enhancements, improvements, and other changes to its products and services at any time and to discontinue any product or service without notice. Customers should obtain the latest relevant information before placing orders and should verify that such information is current and complete.

Warranty information

On-Bright Electronics Corp. warrants performance of its hardware products to the specifications applicable at the time of sale in accordance with its standard warranty. Testing and other quality control techniques are used to the extent it deems necessary to support this warranty. Except where mandated by government requirements, testing of all parameters of each product is not necessarily performed.

On-Bright Electronics Corp. assumes no liability for applications assistance or customer product design. Customers are responsible for their products and applications using On-Bright's components, data sheet and application notes. To minimize the risks associated with customer products and applications, customers should provide adequate design and operating safeguards.

Life support

On-Bright Electronics Corp.'s products are not designed to be used as components in devices intended to support or sustain human life. On-bright Electronics Corp. will not be held liable for any damages or claims resulting from the use of its products in medical applications.

Military

On-Bright Electronics Corp.'s products are not designed for use in military applications. On-Bright Electronics Corp. will not be held liable for any damages or claims resulting from the use of its products in military applications.