



ORIENT-CHIP

■ General Description

The OCH167 Omnipolar Hall effect sensor IC is fabricated from mixed signal CMOS technology. It is comprised of two Hall plates and a CMOS output driver, mainly designed for battery-operation, hand-held equipment (such as Cellular and Cordless Phone, PDA). The total power consumption in normal operation is typically 39μW with a 3V power source. Either north or south poles of sufficient strength will turn the output on. The output will be turned off under no magnetic field. While the magnetic flux density (B) is larger than operating point (BOP), the output will be turned on (low), the output is held until B is lower than release point (BRP), and then turned off.

The OCH167 is available in many flexible packaging options, such as TSOT23-3L, DFN1616-6L, DFN1616-3L, DFN2020-3L, and DFN1216-4L. Operating temperature range of the OCH167 is from -40°C to 85°C.

To minimize the BOM cost, capacitors of the MLCC type are supported, and only one external component are needed to complete the application

■ Features

- Micro power consumption ideal for battery-powered applications
- Omnipolar (operation with magnetic field of either north or south pole), easy to use as output switches with both North and South pole
- Input Voltage Range: 2.2V to 3.65V
- Very High Sensitivity Hall Sensor
- Chopper stabilized amplifier stage
- Good RF noise immunity
- TSOT23-3L/Low profile DFN1616-6L /DFN1616-3L DFN2020-3L DFN1216-4L package
- Not need the push-high resistance

■ Applications

- Cover switch in clam-shell cellular phones
- Cover switch in Notebook PC/PDA
- Contact-less switch in consumer products
- Solid State Switch
- Handheld Wireless Handset Awake Switch
- Lid close sensor for battery-powered devise
- Magnet proximity sensor for reed switch replacement in low duty cycle applications

■ Pin Configuration

(1) TSOT23-3L (Top View)

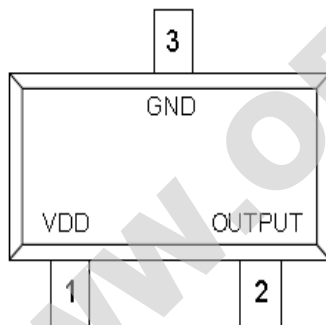

(2) DFN1616-6L (Top View)

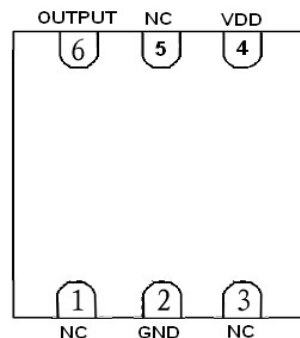

(3) DFN1616-3L (Top View)

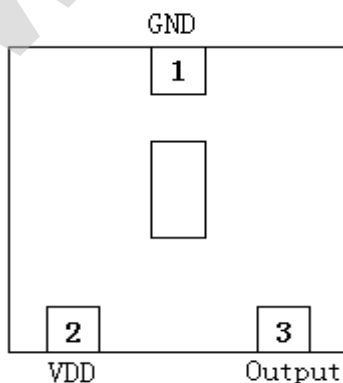

(4) DFN2020-3L (Top View)

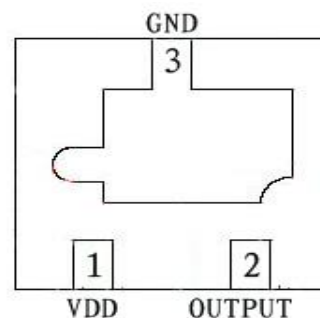



Pin Name	Pin No.				Pin Function
	TSOT23-3L	DFN1616-6L	DFN1616-3L	DFN2020-3L	
VDD	1	4	2	1	Power Supply Input
GND	3	2	1	3	Ground
OUTPUT	2	6	3	2	Output Pin
N.C	-	1, 3, 5	-	-	Not connected

(5) DFN1216-4L (Top View)

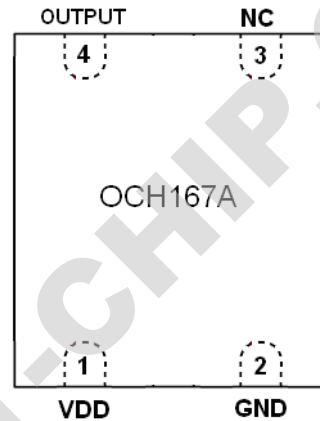
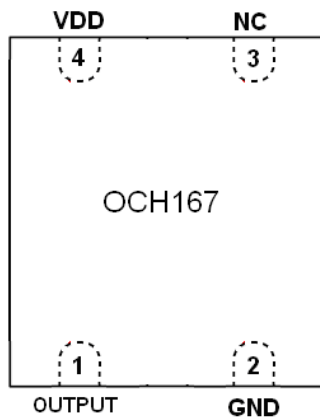

Pin Name	Pin No.		Pin Function
	OCH167	OCH167A	
VDD	4	1	Power Supply Input
GND	2	2	Ground
OUTPUT	1	4	Output Pin
N.C	3	3	Not Connected



■ Typical Application Circuit

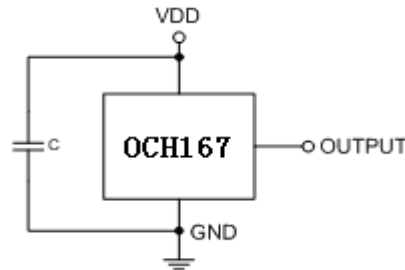

Note: C is for power stabilization and to strengthen the noise immunity, the recommended capacitance is 10nF~100nF.

■ Ordering Information

(1)

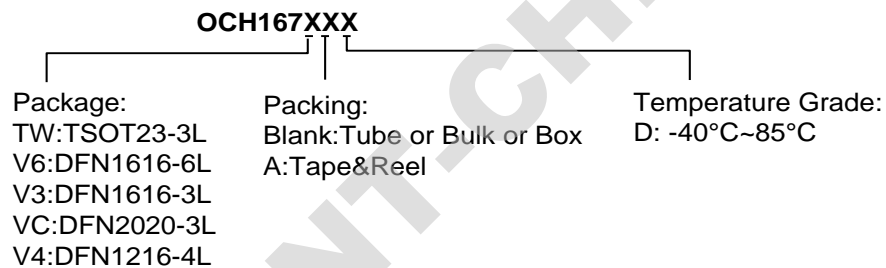

(2)

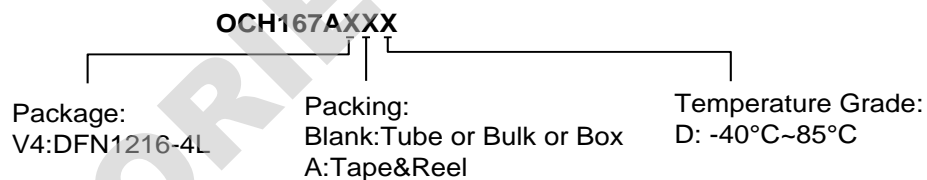

Part Number	Package Type	Package Qty	Brp (Gauss)	Bop (Gauss)	Temperature	Eco Plan	Lead/Ball Finish
OCH167TWAD	TSOT23-3L	7-in reel 3000pcs/reel	±10 ~ ±30	±20 ~ ±60	-40~85°C	Green	Cu Sn
OCH167V6AD	DFN1616 -6L	7-in reel 3000pcs/reel	±10 ~ ±30	±20 ~ ±60	-40~85°C	Green	Cu NIPDAU
OCH167V3AD	DFN1616 -3L	7-in reel 3000pcs/reel	±10 ~ ±30	±20 ~ ±60	-40~85°C	Green	Cu NIPDAU
OCH167VCAD	DFN2020-3L	7-in reel 3000pcs/reel	±10 ~ ±30	±20 ~ ±60	-40~85°C	Green	Cu NIPDAU
OCH167V4AD	DFN1216-4L	7-in reel 3000pcs/reel	±10 ~ ±30	±20 ~ ±60	-40~85°C	Green	Cu NIPDAU
OCH167AV4AD	DFN1216-4L	7-in reel 3000pcs/reel	±10 ~ ±30	±20 ~ ±60	-40~85°C	Green	Cu NIPDAU

注：想进一步了解产品咨询，请直接点击[申请样品](#)。我们会第一时间联系您！谢谢！