

One-Channel High Power LED Controller

General Description

The OCP8107 is a high power LED driver, non-synchronous boost controller. Ideal for use, the OCP8107 can power the LED backlight in LCD panels. It contains all of the features needed to implement single ended primary topologies.

The OCP8107 is suitable for topologies which require a ground source N-channel FET including boost, SEPIC and various LED driver applications.

The device features include over-voltage protection (OVP), under-voltage lock-out (UVLO) and Over Temperature protection (OTP). A soft-start feature is provided to minimize in-rush current during start-up.

The OCP8107 is available in SOP-8L package, and it is RoHS compliant. Operating temperature range of the OCP8107 is from -40°C to 85°C.

Features

- Wide Supply Voltage Range: 4.0V ~ 18V
- For Boost, SEPIC, LED Driver Applications
- Number of LEDs in series limited by external MOSFETs rating
- External enable control
- EN PWM Dimming Control
- Fixed Operation Frequency
- Over-voltage protection
- Low in-rush current soft-start function
- Under-voltage lock-out
- Thermal shutdown
- Low Standby current
- T_A = -40 ~ 85 °C
- Available in SOP-8L Package

Applications

- LCD White LED Backlighting
- LCD TVs
- Automotive and Infotainment Displays
- Battery Powered Systems
- Industrial Control Systems

Pin Configuration

SOP-8L (Top View)

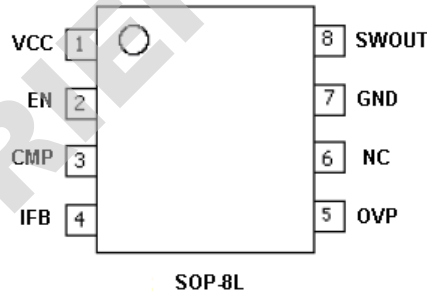

Figure 1, Pin Assignments of OCP8107

Pin Name	Pin No. SOP-8L	I/O	Pin Function
VCC	1	P	Input Power for controller and internal MOSFET driver
EN	2	I	ON/OFF control for the controller
CMP	3	I/O	Output of the error amplifier
IFB	4	I	LED Current Sense Input
OVP	5	I	Output over-voltage protection sense
NC	6	-	No connection
GND	7	P	Ground
SWOUT	8	O	Boost Power MOSFET Drive Output

■ Typical Application Circuit

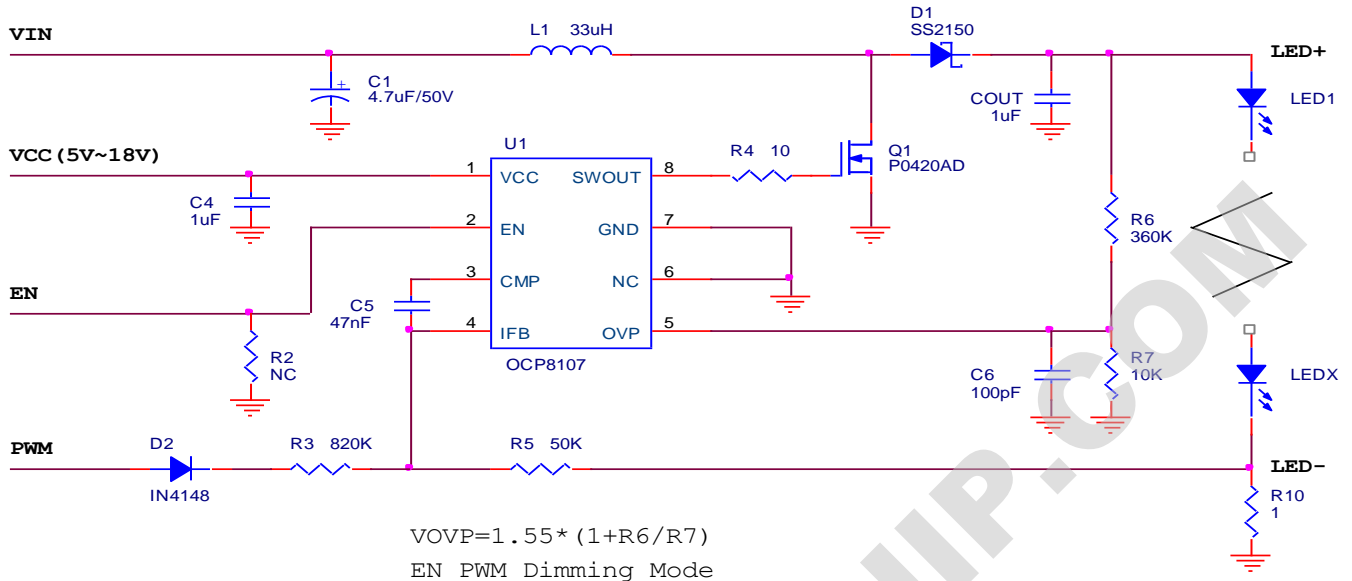

Figure 2A, EN PWM Dimming Typical Application Circuit of OCP8107

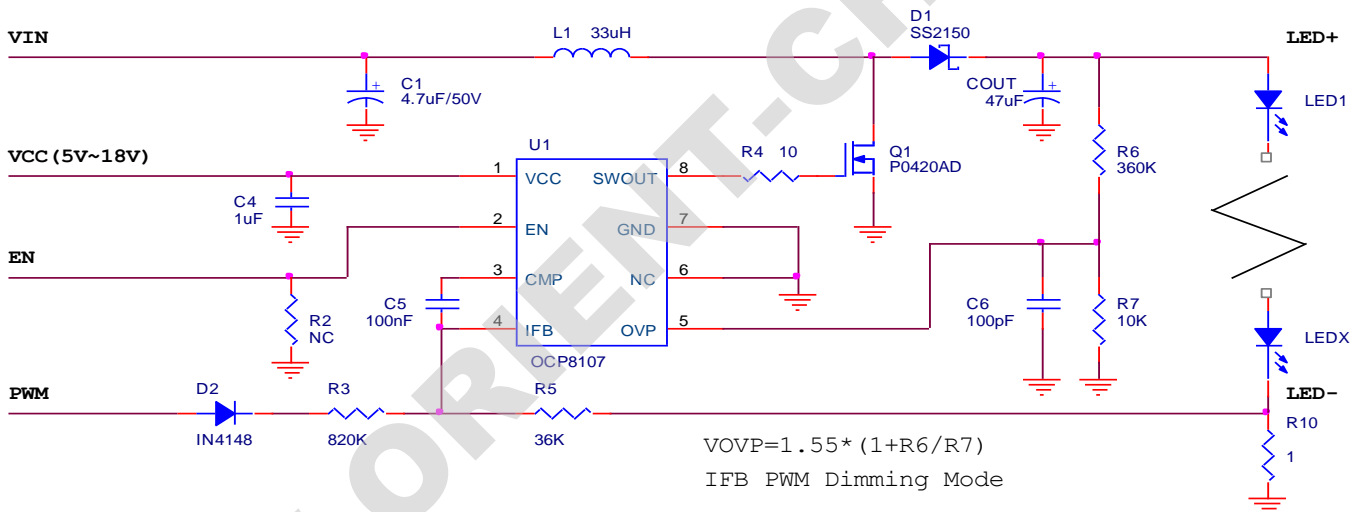

Figure 2B, IFB Dimming Typical Application Circuit of OCP8107

■ Ordering Information

OCP8107XXX

Package:
S: SOP-8L

Packing:
Blank: Tube or Bulk
A: Tape & Reel

Temperature Grade:
D: -40~85°C

Part Number	Package Type	Package Qty	Temperature	Eco Plan	Lead
OCP8107SAD	SOP-8L	13-in reel 2500pcs/reel	-40~85°C	Green	Cu
OCP8107SD	SOP-8L	100pcs/Tube	-40~85°C	Green	Cu

注：想进一步了解产品咨询，请直接点击[申请样品](#)。我们会第一时间联系您！谢谢！