



### ■ General Description

The OCP8110A is current-regulated charge pump ideal for powering high brightness LEDs for camera flash applications. The charge pump can be set to regulate two current levels for FLASH and TORCH modes.

The OCP8110A automatically switches modes between step-up and step-down ensuring that LED current does not depend on the forward voltage. It switches at 1.8MHz, allowing the use of tiny components. The supply voltage ranges from 2.7V to 5.5V and is ideally suited for all applications powered by a single Li-Ion battery cell or three to four NiCd, NiMH, or Alkaline battery cells.

The OCP8110A also features a very low shutdown current (less than 1 $\mu$ A), an automatic soft-start mode to limit inrush current, as well as over current, over voltage and over temperature shutdown control.

A Low current sense reference voltage (50mV) allows the user of small 0603 current sensing resistors.

The OCP8110A is offered in Green 10-pin DFN package and is specified over an ambient temperature range of -40°C to 85°C.

### ■ Features

- Output Current up to 500mA at  $V_{IN}=3.6V$
- Up to 94% Efficiency in Torch Mode
- Adjustable FLASH Mode Current
- Minimum External Components: No Inductors
- Automatic Buck/Boost Mode Switchover
- Wide  $V_{IN}$  Range: 2.7V to 5.5V
- High Frequency Operation: 1.8MHz
- 50mV Reference for low Loss Sensing
- $ISD < 1\mu A$  in Shutdown
- PWM Dimming Control
- Automatic Soft Start Limits Inrush Current
- Over Voltage Protection on Output
- Over Current Protection
- Over Temperature Protection
- Low Input and Output Ripple and Low EMI
- Ultra-low Dropout Voltage in Buck Mode
- Space Saving RoHS Compliant, Lead Free Package: 10-pin 3mm x 3mm DFN

### ■ Applications

- White LED Torch/Flash for Cell Phones, DSCs, and Camcorders
- White LED Backlighting
- Generic Lighting/Flash/Strobe Applications
- General Purpose High Current Boost

### ■ Pin Configuration

DFN3030-10L (Top View)

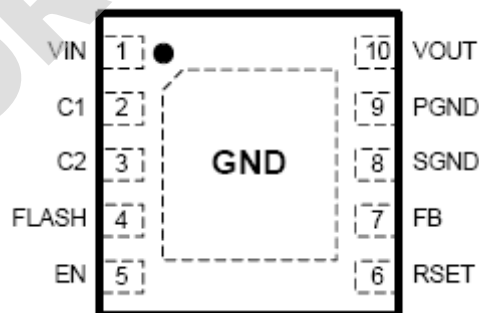

Figure 1, Pin Assignments of OCP8110A



Pin Name	Pin No.	Pin Function
	DFN3030-10	
V <sub>IN</sub>	1	Input Voltage for the charge pump. Decouple with 4.7μF or 10uF ceramic capacitor close to the pins of the IC.
C1	2	Positive input for the external flying capacitor. Connect a ceramic 1 μF capacitor close to the pins of the IC.
C2	3	Negative input for the external flying capacitor. Connect a ceramic 1 μF capacitor close to the pins of the IC.
FLASH	4	Logic input to toggle operation between FLASH and TORCH mode. In TORCH mode, FLASH=GND, FB pin is regulated to the internal 50mV reference. In FLASH mode, FLASH=High, FB pin reference voltage can be adjusted by changing the resistor from R <sub>SET</sub> pin to ground. Choose the external current sense resistor (R <sub>SENSE</sub> ) based on desired current in TORCH mode. This pin does not have an internal pull-up/pull- down; do not leave this pin floating.
EN	5	Shutdown control input. Connect to V <sub>IN</sub> for normal operation, connect to ground for shutdown. Don't leave this pin floating.
R <sub>SET</sub>	6	Connect a resistor from this pin to ground. When in FLASH mode (FLASH = High) this resistor sets the current regulation point according to the following: $V_{FB} = \frac{1.26V}{R_{SET}} * 11.2k\Omega \text{ (Flash Mode)}$
FB	7	Feedback input for the current control loop. Connect directly to the current sense resistor.
SGND	8	Internal ground pin. Control circuitry returns current to this pin.
PGND	9	Power ground pin. Flying capacitor current returns through this pin.
V <sub>OUT</sub>	10	Charge Pump Output Voltage. Decouple with an external capacitor. At least 1 μF is recommended. Higher capacitor values reduce output ripple
GND	Exposed Pad	Exposed pad should be soldered to PCB board and connected to GND.

### ■ Typical Application Circuit

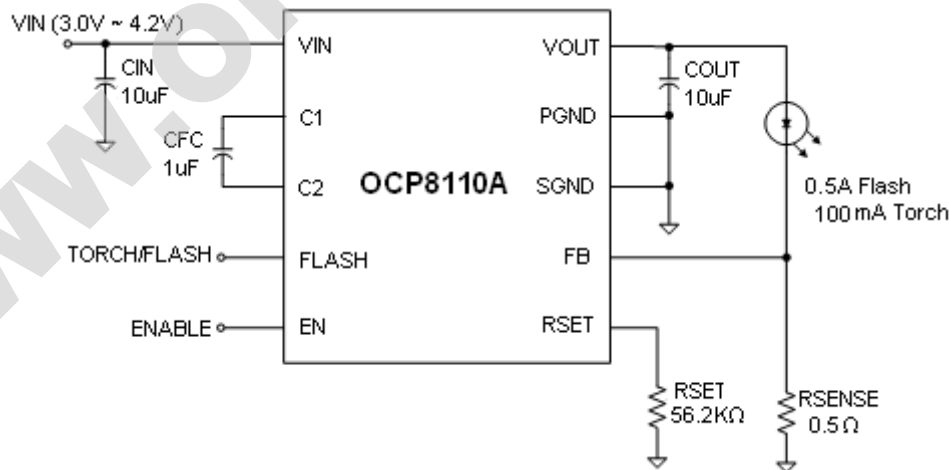
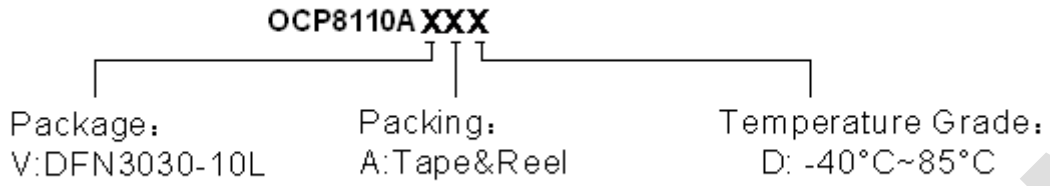

Figure 2, Typical Application Circuit of OCP8110A



Ordering Information



Part Number	Driver Capability	Package Type	Package Qty	Temperature	Eco Plan	Lead
OCP8110AVAD	0.5A	DFN3030-10L	13-in reel 3000pcs/reel	-40~85°C	Green	Cu

注：想进一步了解产品咨询，请直接点击[申请样品](#)。我们会第一时间联系您！谢谢！

