



## High Efficiency Synchronous Boost Converter For 1.5A WLED Flash

### ■ General Description

The OCP8132 is a 2MHz fixed frequency synchronous boost converter, optimized for maximum 1.5A camera flash application and maximum 800mA movie mode applications using high-current white LEDs in all single cell Li-ion powered products. An adaptive regulation method ensures the current for each LED remains in regulation and maximizes efficiency.

Two simple logic control inputs (ENM and ENF) enable and disable flash and movie mode operation of the OCP8132. Movie-mode and Flash-mode current levels are independently fixed by two separate resistors (RM and RF). For Flash mode, a default timer can be used either to terminate a flash event or as a safety flash timer. One or two LEDs can be connected to the OCP8132; in the case of two LEDs the output current is matched between each diode.

The OCP8132 integrate an input voltage monitor to monitor low battery conditions and can force the LED current into movie mode, and an input voltage flash monitor (flash current rising) operates as follows: during flash current turn-on the input voltage falls below the VIN Flash Monitor threshold, the flash current is stopped at the level that the current ramp had risen to, at the time of the VIN Flash Monitor events.

Thermal regulation is integrated in Flash mode to limit the IC's temperature and continuously provide the maximum allowed output current.

The OCP8132 contain a thermal management system to protect the device; a internal over-voltage protection (OVP) circuitry prevents damaged to the OCP8132 from open LED or open circuit conditions; and a cycle-by-cycle current limit prevents damage to the OCP8132. Built-in circuitry prevents excessive inrush current during start-up. The shutdown feature reduces quiescent current to less than 1.0 $\mu$ A.

The 2MHz switching frequency allow for the use of tiny, low profile (1 $\mu$ H or 2.2 $\mu$ H) inductors and 4.7 $\mu$ F ceramic capacitors. The device is available in 14-pin 2mmX3mm DFN package and is rated over the -40°C to 85°C.

### ■ Features

- Input Voltage Range : 2.7V to 4.8V
- Dual Channel Output
- Drives up to 1.5A Regulated Output Current (0.75A per Channel)
- High Efficiency PWM Boost Converter
- 2.0MHz Fixed Switching Frequency
- Up to 97% Efficiency with Small Inductor 1 $\mu$ H
- Integrated Soft-Start Eliminates Inrush Current
- Under Voltage Lock-Out
- Over-Temperature Protection
- Thermal Sensing and Current Scale Back
- VIN Flash Monitor and Battery Voltage Sensing and Current Scale-Back
- Optimize Flash Current During Low Battery
- Over Voltage (Open LED) Protection
- LED Short Circuit Protection
- Movie Mode Dimming via Maximum 10KHz PWM Control
- 800mS Flash Timer Control
- Cycle by Cycle Current Limit
- Separate Hardware Flash and Movie Enable
- Independently Set Flash/Movie Currents
  - Flash Mode Current Up to 1.5A
  - Movie Mode Current Up to 800mA
- Two Resistors Set Flash and Movie Current Independently
- Small Solution Size
- Less than 1 $\mu$ A Shutdown Current
- RoHS and Green Compliant
- 14-pin, 2mm X 3mm DFN Packages
- -40°C to +85 °C Temperature Range

### ■ Applications

- Camera Flashes and Movies
- Cell Phones or Smart Phones
- PDAs and Digital Camera
- White LED Biasing
- Mobil Handsets
- Tablet PCs and Laptops/Netbooks
- Camcorder Video Light (Movie Light)

**Pin Configuration**  
**DFN2030-14L (Top View)**

Figure 1, Pin Assignments of OCP8132

Pin Name	Pin No.	I/O	Pin Function
	DFN2030-14L		
RM	1	I/O	Movie mode current setting input. A 34kΩ resistor from RM to GND sets the desired movie current available at LED1 and LED2 up to 400mA total current. Each LED1 and LED2 channel will conduct 50% of the maximum programmed current.
RF	2	I/O	Flash mode current setting input. A 9.1kΩ resistor from RF to GND sets the maximum flash current available at LED1 and LED2 up to 1.5A total current. Each LED1 and LED2 channel will conduct 50% of the maximum programmed current.
AGND	3	P	Analog Ground and flash ground.
VIN	4	P	Power input. Connect VIN to the input power supply voltage. Connect a 4.7uF ceramic capacitor from VIN to GND as close as possible to OCP8132.
SW	5	O	Drain connection for internal NMOS and Synchronous PMOS Switches.
SW	6	O	Drain connection for internal NMOS and Synchronous PMOS Switches.
PGND	7	P	Boost power ground pin. Connect PGND to GND and FGND at a single point as close as possible to OCP8132.
OUT	8, 9	O	Power output of the boost converter. Connect a 4.7uF ceramic capacitor from OUT to PGND as close as possible to the OCP8132. Connect OUT to the anodes of the Flash LEDs.
ENF	10	I	Flash mode enable pin. A low to high transition on the ENF pin initiates flash mode current level set by RF resistor. ENF is a active high control input with a internal 300kΩ resistance to GND.
ENM	11	I	Movie mode enable pin. A low to high transition on the ENM pin initiates movie mode current level set by RM resistor. ENM is a active high control input with a internal 300kΩ resistance to GND.
LED1	12	O	Channel 1 flash LED pin. Connect cathode of a flash LED to FGND. For a single flash LED, connect LED1 and LED2 together. For two flash LEDs, each output will conduct of 50% of the total flash current. LED1 is high impedance during shutdown.
AGND	13	P	Analog Ground and flash ground.
LED2	14	O	Channel 2 flash LED pin. Connect cathode of a flash LED to FGND. For a single flash LED, connect LED1 and LED2 together. For two flash LEDs, each output will conduct of 50% of the total flash current. LED2 is high impedance during shutdown.
GND	EP	P	Exposed paddle (bottom). Connect EP to PGND as close as possible.

■ Typical Application Circuit

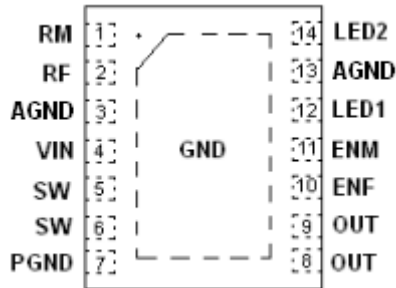
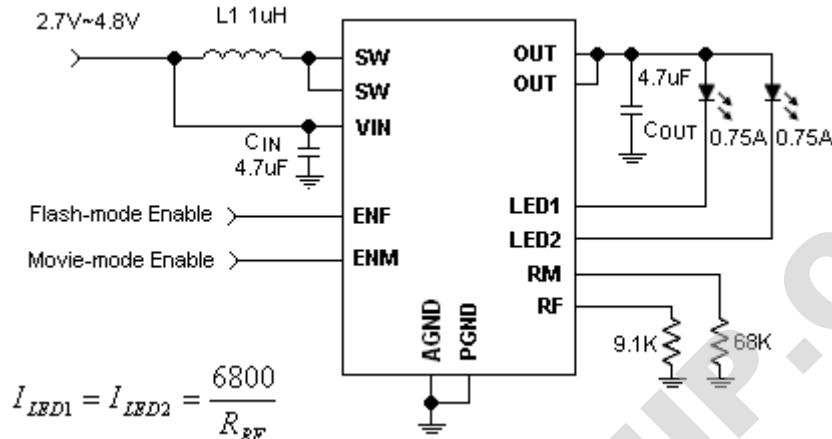

Figure 2A, Typical Application Circuit of OCP8132

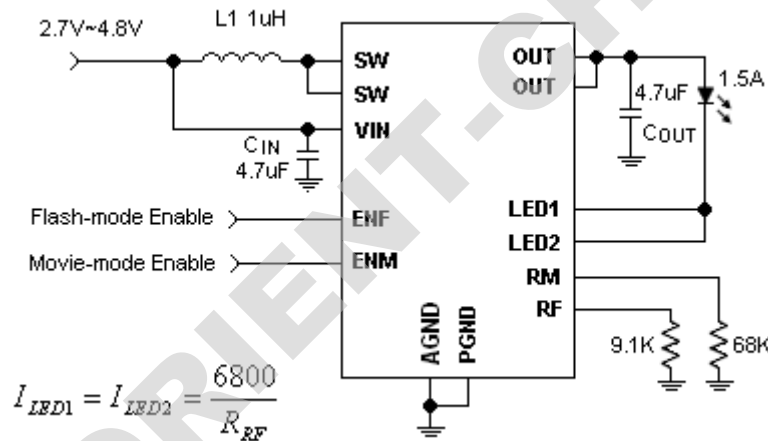

Figure 2B, Typical Application Circuit of OCP8132 (One Channel)

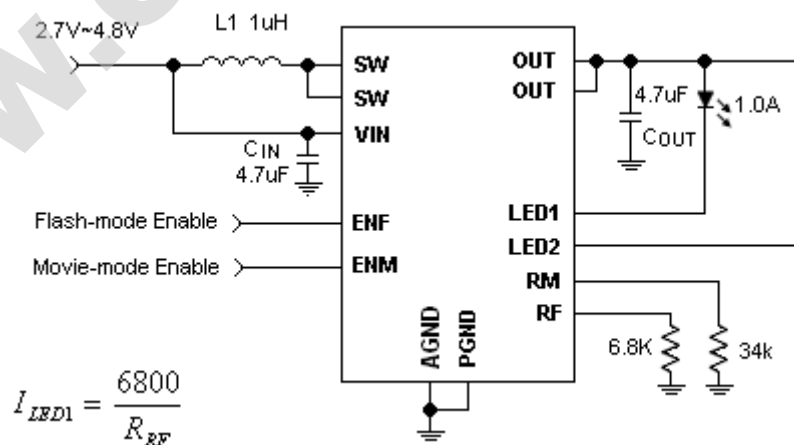
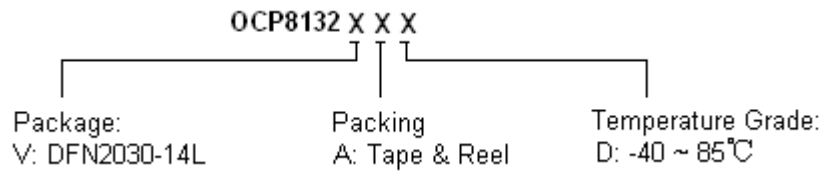

Figure 2C, Typical Application Circuit of OCP8132 (One Channel)



Ordering Information



Part Number	Driver Capability	Package Type	Package Qty	Temperature	Eco Plan	Lead
OCP8132VAD	1.5A or 2*0.75A	DFN2030-14L	7-in reel 3000pcs/reel	-40~85°C	Green	Cu

注：想进一步了解产品咨询，请直接点击[申请样品](#)。我们会第一时间联系您！谢谢！

WWW.ORIENT-CHIP.COM