



## White LED Driver With Digital and PWM Brightness Control

### ■ General Description

With a 40-V rated integrated switch FET, the OCP8178 is a boost converter that drives LEDs in series. The boost converter runs at 600kHz fixed switching frequency to reduce output ripple, improve conversion efficiency, and allows for the use of small external components.

The default white LED current is set with the external sensor resistor  $R_{set}$ , and the feedback voltage is regulated to 200mV, as shown in the typical application. During the operation, the LED current can be controlled using the 1-wire digital interface through the CTRL pin. Alternatively, a pulse width modulation (PWM) signal can be applied to the CTRL pin through which the duty cycle determines the feedback reference voltage. In either digital or PWM mode, the OCP8178 does not burst the LED current; therefore, it does not generate audible noises on the output capacitor. For maximum protection, the device features integrated open LED protection that disables the OCP8178 to prevent the output voltage from exceeding the IC's absolute maximum voltage ratings during open LED conditions.

The OCP8178 is available in a space-saving, 2mm x 2mm DFN package with thermal pad.

### ● Features

- 2.7V to 5.5V Input Voltage Range
- 38V Open LED Protection
- 200mV Reference Voltage
- Flexible Digital and PWM Brightness Control
- Built-in Soft Start
- Up to 90% Efficiency
- 2mm x 2mm x 0.8mm DFN2X2-6L(6-pinDFN ) Package With Thermal Pad

### ● Applications

- Cellular Phones
- Portable Media Players
- Ultra Mobile Devices
- GPS Receivers
- White LED Backlighting for Media Form Factor Display

■ Pin Configuration  
DFN2X2-6L

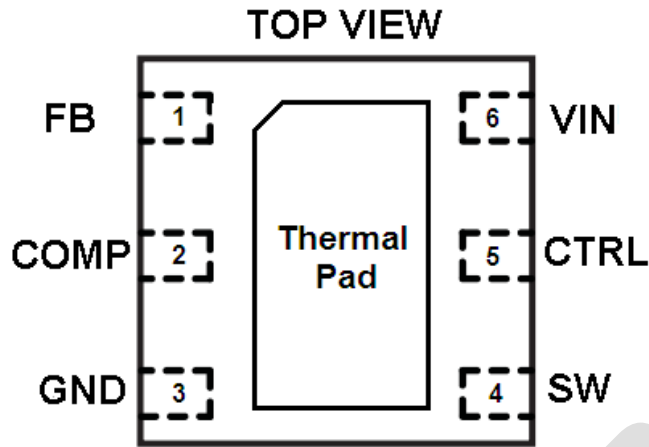

Figure 1, Pin Assignments of OCP8178

Pin Name	Pin No.	I/O	Pin Function
	DFN-6pins		
VIN	6	I	The input supply pin for the IC. Connect VIN to a supply voltage between 2.7V and 5.5V.
SW	4	O	This is the switching node of the IC. Connect the inductor between the VIN and SW pin. This pin is also used to sense the output voltage for open LED protection
GND	3	I	Ground
FB	1	I	Feedback pin for current. Connect the sense resistor from FB to GND.
COMP	2	O	Output of the transconductance error amplifier. Connect an external capacitor to this pin to compensate the converter.
CTRL	5	I	Control pin of the boost converter. It is a multi-functional pin which can be used for enable control, PWM and digital dimming.
Thermal Pad			The thermal pad should be soldered to the analog ground plane. If possible, use thermal via to connect to ground plane for ideal power dissipation.

■ Typical Application Circuit

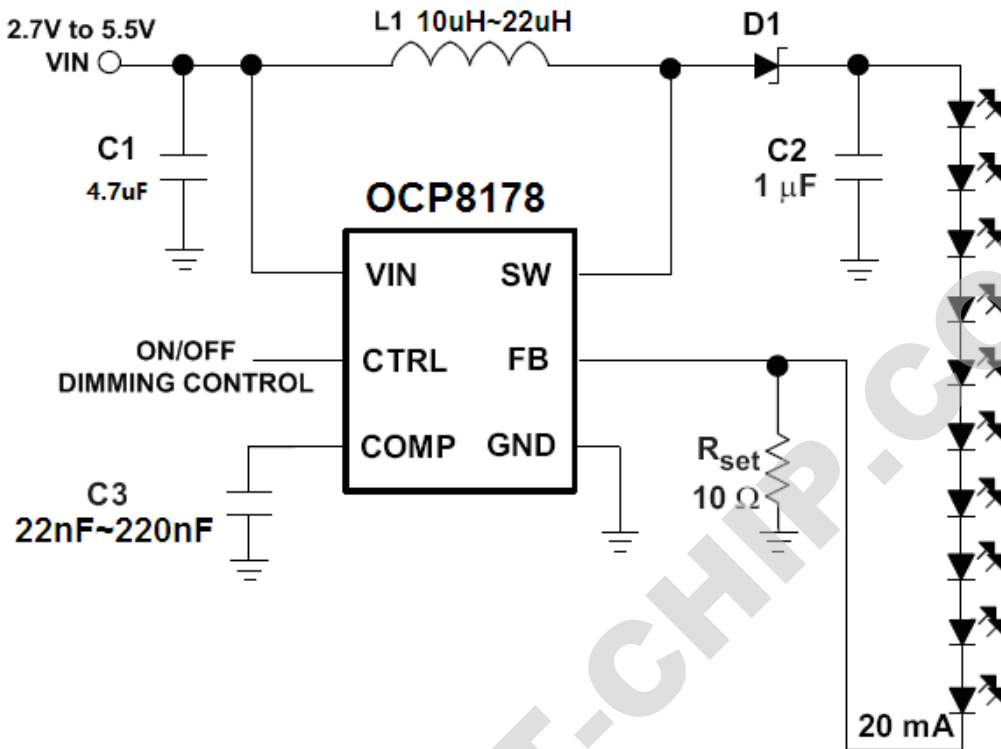

Figure 2, Typical Application Circuit of OCP8178

■ Ordering Information

Part Number	Maximum VOUT	VFB	Package Type	Package Qty	Temperature	Eco Plan	Lead/Ball Finish
OCP8178VAD	38V	200mV	DFN2X2-6L	7-in reel 3000pcs/reel	-40~85°C	Green	NIPDAU

注：想进一步了解产品咨询，请直接点击[申请样品](#)。我们会第一时间联系您！谢谢！