

### Features

- Surface mountable
- TTL compatible output
- Wide supply voltage range
- Also available with mounted reticle

### Absolute Maximum Ratings

T<sub>A</sub> = 25 °C unless otherwise noted)

Storage Temperature	-55 °C to +125 °C
Operating Temperature	-20°C to 80°C
Supply Voltage	24.0 V
Output Voltage	24.0 V
Output Current	14.0 mA
Power Dissipation	500.0 mW
Soldering Temperature (Vapor Phase Reflow for 30 sec.)	235 °C

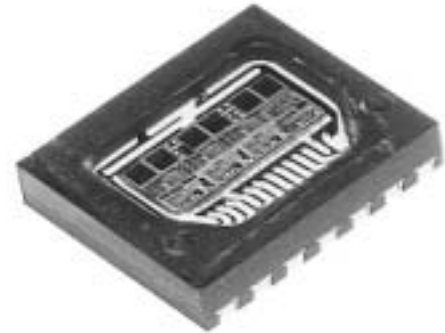

### Description

The OL5003 is a hybrid sensor consisting of three channels. This differential optical comparator IC is specifically designed for high speed / high resolution encoder applications. The open collector output switches based on the comparison of input photodiode's light current levels. Logarithmic amplification of the input signals makes possible operation over a wide range of light levels.

The package is surface mountable with two alignment holes and made from a custom, opaque Polyimide which shields the active devices from stray light. The high temperature laminate can withstand multiple exposures to the most demanding soldering conditions. Wrap around contacts are gold plated for exceptional storage and wetting characteristics.

### Electrical Characteristics

(T<sub>A</sub> = 25 °C unless otherwise noted)

Parameters	Symbol	Min.	Typ.	Max.	Units	Test Conditions	Notes
Supply Voltage	V <sub>DD</sub>	4,75		24	V		
Supply Current	I <sub>CC</sub>		9.0	20.0	mA	V <sub>CC</sub> = 24.0 V	1
Low Level Output Voltage	V <sub>OL</sub>		0.3	0.4	V	I <sub>OL</sub> = 14.0 mA, V <sub>CC</sub> = 4.5 V	2
High Level Output Current	I <sub>OH</sub>		0.1	1.0	µA	V <sub>CC</sub> = V <sub>O</sub> = 20.0 V	3
Optical Hysteresis	OPT-HYS	2.0	15.0	40.0	%	V <sub>CC</sub> = 5.0 V, I <sub>ol</sub> = 1.0 mA	4, 7
Optical Offset	OPT-OFF	-40.0	10.0	+40.0	%	V <sub>CC</sub> = 5.0 V, I <sub>ol</sub> = 1.0 mA	4, 7
Frequency Response	f <sub>MAX</sub>		100.0	600.0	kHz	V <sub>CC</sub> = 5.0 V,	5
Output Rise Time	t <sub>LH</sub>		1.0		µs	R1 = 100.0 Ω	6
Output Fall Time	t <sub>HL</sub>		300.0		ns	C1 = 50.0 pF	

### Notes

1. Pin (+) = 1.2 µW and Pin (-) = 0.8 µW.
2. Pin (+) = 100.0 nW and Pin (-) = 1.0 µW.
3. Pin (+) = 1.0 µW and Pin (-) 100.0 nW.
4. Pin (-) held at 1.0 µW while Pin (+) is ramped from 0.5 µW to 1.5 µW and back to 0.5 µW.
5. Pin (+) modulated from 1.0 µW to 2.0 µW. Pin (-) modulated from 1.0 µW to 2.0 µW with phase shifted 180° with respect to Pin (+). Use 100 kΩ trimpot to set the output signal to 50% duty cycle for maximum operating frequency.
6. Measured between 10% and 90% points.

## 3 Channel Incremental Encoder Sensor with adjustable phase angle

7. Optical Hysteresis and Optical offset are found by placing 1.0  $\mu\text{W}$  of light on the inverting photodiode and ramping the light intensity of the noninverting input from .5  $\mu\text{W}$  up to 1.5  $\mu\text{W}$  and back down. This will produce two trigger points, an upper trigger point and lower trigger point. These points are used to calculate the optical hysteresis and offset. These are defined as:

$$\text{Optical Hysteresis [\%]} = \frac{100 \times (P_{\text{rise}} - P_{\text{fall}})}{P_{\text{in(-)}}}$$

$$\text{Optical Offset [\%]} = \frac{100 \times (P_{\text{average}} - P_{\text{in(-)}})}{P_{\text{in(-)}}}$$

Where:

P in (-) = Light level incident upon the "-" photodiode on the I.C. chip (Pin(-) = 1.0  $\mu\text{W}$ ).

P rise = Value of light power level incident upon the "+" photodiode that is required to switch the digital output when the light level is an increasing level (rising edge).

P fall = Value of light power level incident upon the "+" photodiode that is required to switch the digital output when the light level is a decreasing level (falling edge).

$$P_{\text{average}} = \frac{P_{\text{rise}} + P_{\text{fall}}}{2}$$

### Notes

1. A capacitance of a value between 0.001 to 0.01  $\mu\text{F}$  connected as close as possible to the trim terminals is recommended if the device appears to be susceptible to noise transients. It is left to the user to determine the best value for the application.
2. The OL7272 is recommended as a means of isolating the „DOC“ comparitor circuitry from transients induced by inductive and capacitive loads.
3. It is recommended that a decoupling capacitor be placed as close as possible to the device.

### Application Circuit

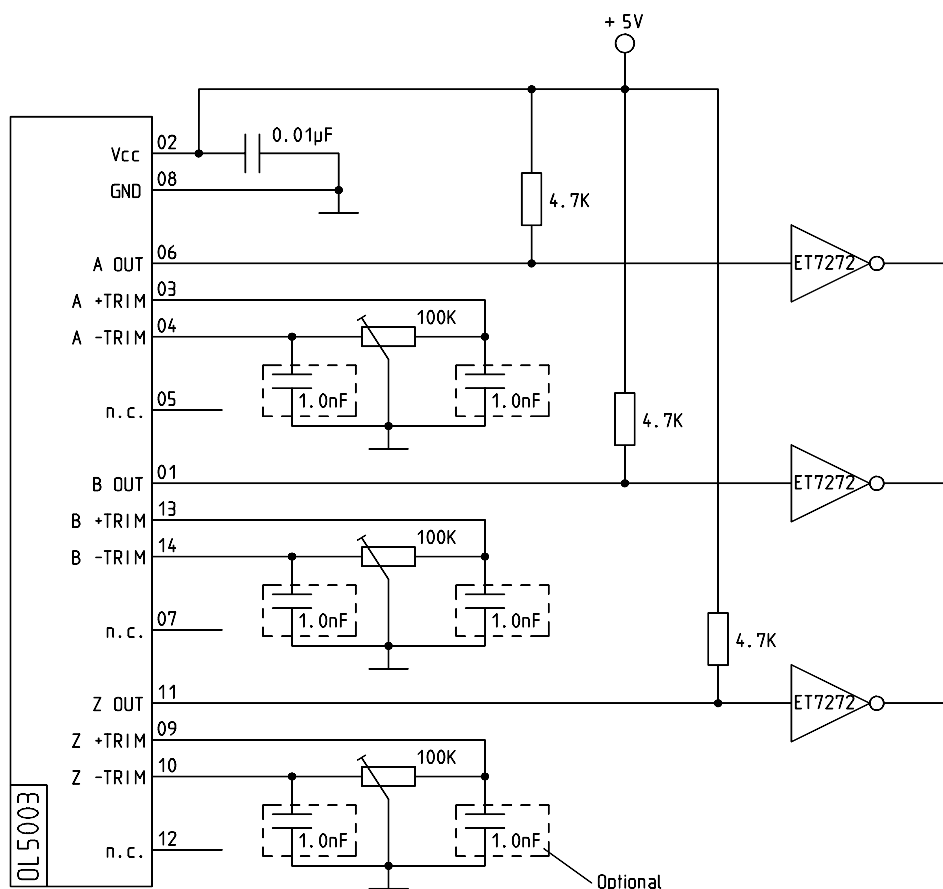

# OL 5003

3 Channel Incremental Encoder Sensor with adjustable phase angle

### Top View

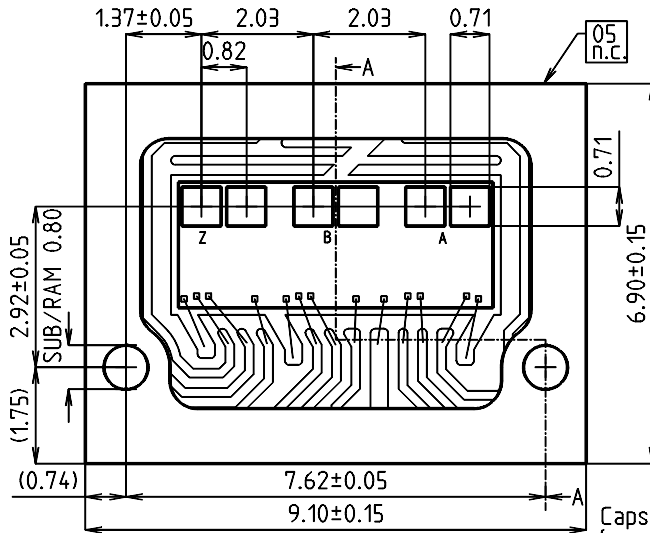

SMT Solder Pad  
0.20 (Infil)

Cross-sectional picture A-A

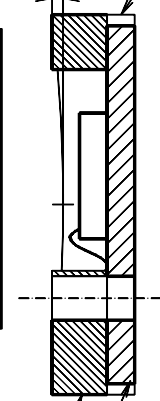

Capsulation frame (RAM) 1.0±0.1  
Base (SUB) 0.5±0.1

### Bottom View

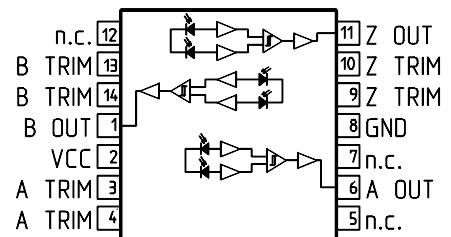
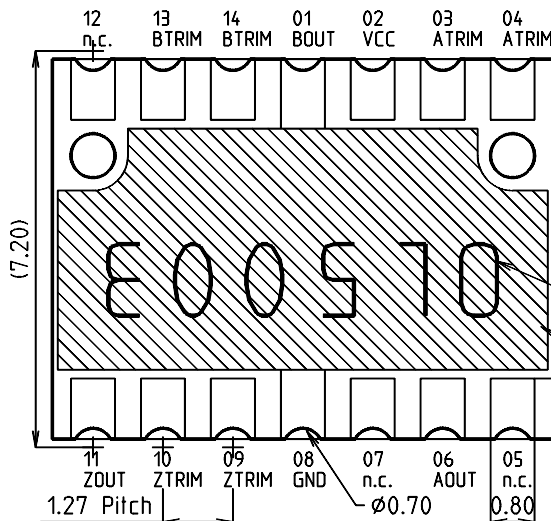

Legend print  
Component name  
Solder resist

Chip type ET5003 (1x)