

1-4-31

**SIEMENS**

**SUPER-RED OLB 2350**

**YELLOW YLB 2450**

**GREEN GLB 2550**

**LIGHT BARS**

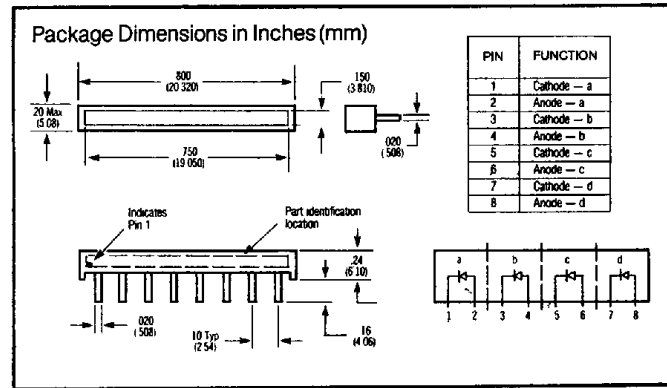
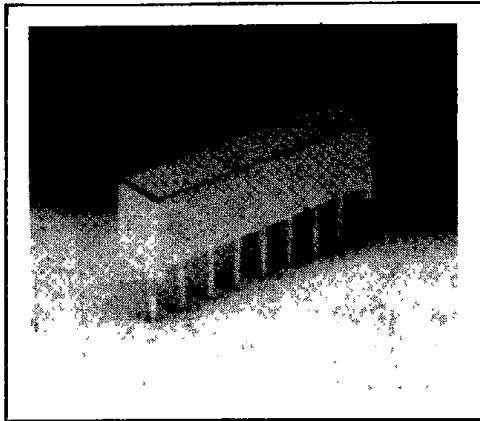

**FEATURES**

- Small Rectangular Package
- Uniform Light Emitting Area
- Excellent ON/OFF Contrast
- Choice of Three Colors
- Categorized for Light Output
- Yellow and Green Categorized for Dominant Wavelength
- Panel or Legend Mountable
- Can be Mounted on P.C. Boards or SIP/DFP Sockets
- X-Y Stackable
- Suitable for Multiplexing
- IC Compatible

**APPLICATIONS**

These devices are ideally suited for:

- Message Annunciators
- Positions/Status Indicators
- Telecommunications Indicators
- Bar Graphs

**DESCRIPTION**

The OLB 2350/YLB 2450/GLB 2550 light bars are rectangular displays designed for applications requiring a large light emitting area. They are configured in a single in-line package and contain a single light emitting area. The OLB 2350 and YLB 2450 devices utilize four LED chips which are made from GaAsP on a transparent GaP substrate. The GLB 2550 device utilizes four chips made from GaP on a transparent GaP substrate.

**Maximum Ratings**

	OLB 2350 & GLB 2550	YLB 2450
Average Power Dissipation per LED chip	135mW	85mW
Peak Forward Current per LED chip Ta = 50°C (max pulse width = 2ms)	90mA	60mA
Average Forward Current per LED	25mA	20mA
Pulsed conditions (Ta = 50°C)		
DC Forward Current Per LED (Ta = 50°C)	30mA	25mA
Reverse Voltage per LED chip	6V	
Operating Temperature	-40°C to +85°C	
Storage Temperature	-40°C to +85°C	
Lead Soldering Temperature, 1/16 inch below seating plane	260°C for 3 sec	
Junction Temperature	100°C	

**Electrical/Optical Characteristics (@ 25°C)**

Parameters	Min.	Typ.	Max.	Units	Test Conditions
Luminous Intensity					
OLB2350	9	20		mcd	20mA DC
YLB2450	8	12		mcd	20mA DC
GLB2550	7.5	20		mcd	20mA DC
Peak Wavelength					
OLB2350		635		nm	
YLB2450		583		nm	
GLB2550		565		nm	
Dominant Wavelength					
OLB2350		626		nm	
YLB2450		585		nm	
GLB2550		572		nm	
Forward Voltage					
OLB2350	1.9	2.6		V	If = 20mA
YLB2450	2	2.6		V	If = 20mA
GLB2550	2.1	2.6		V	If = 20mA
Reverse Voltage					
OLB2350	6	15		V	IR = 100µA
YLB2450	6	15		V	IR = 100µA
GLB2550	6	15		V	IR = 100µA