

◎ SURFACE MOUNT LED LAMPS

表面黏著型發光二極體指示燈

Rev : A Date : 2001/10/01

GH-S170 Series Electro-Optical Characteristics:

Code for parts GH-XXXXX	Lighting Color	Material	V _F (V)		λ (nm)			I _V (mcd)	Internal Circuit
			typ	max	λ _D	λ _P	Δλ	typ	
RSS170TS-ESE	Red	GaAlAs	1.80	2.30	643	660	25	19	
RSS170TS-DPG	Red	AlGaInP	1.90	2.40	631	640	23	52	
OLS170TS-DPG	Orange	AlGaInP	1.90	2.40	624	634	25	67	
OIS170TS-DPG	Orange	AlGaInP	1.90	2.40	615	620	18	75	
AJS170TS-DPG	Amber	AlGaInP	1.90	2.40	605	610	25	52	
ALS170TS-DPG	Amber	AlGaInP	1.90	2.40	595	598	20	75	
YVS170TS-DPE	Yellow	AlGaInP	2.00	2.50	593	594	32	57	
YHS170TS-EPE	Yellow	GaAsP	2.10	2.50	587	586	37	7	
GBS170TS-DPG	Green	AlGaInP	2.10	2.60	578	575	18	37	
GUS170TS-EPE	Green	GaP	2.25	2.70	572	567	32	17	
GPS170TS-EPE	Green	GaP	2.20	2.70	573	567	30	15	
GES170TS-IPG	Green	InGaN	3.20	3.80	527	525	40	120	
GGs170TS-IPG	Green	InGaN	3.30	4.00	509	505	37	120	
BJS170TS-JPH	Blue	InGaN	3.40	4.00	465	460	68	36	
BVS170TS-EPC	Blue	GaN/SiC	4.00	4.50	465	430	60	8	

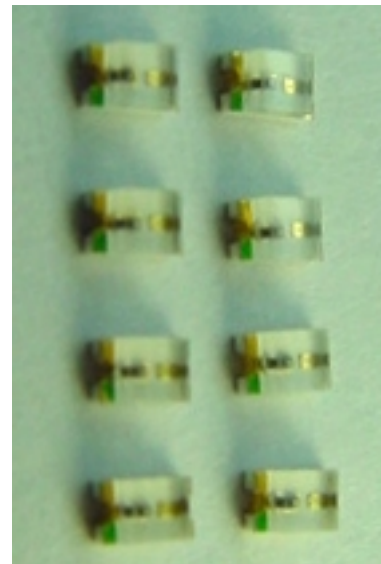

◎ Package Outline Drawing:

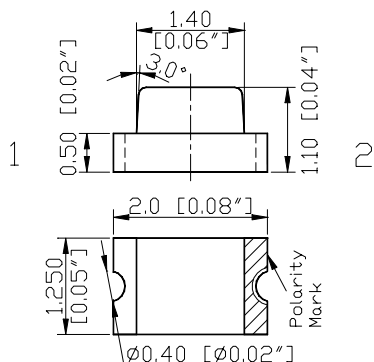

- NOTES:**
1. All dimensions are in millimeters (inches);
 2. Tolerance are $\pm 0.1\text{mm}$ (0.004inch) unless otherwise noted;
 3. Resin color: water clear.

* Soldering iron

Basic spec is $\leq 5\text{sec}$ when 260°C . If temperature is higher, time should be shorter ($+10^\circ\text{C} \rightarrow -1\text{sec}$). Power dissipation of iron should be smaller than 15W, and temperatures should be controllable. Surface temperature of the device should be under 230°C .

* Recommended Soldering Pattern For Reflow Soldering

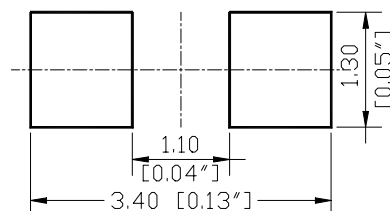

* Recommended Reflow Soldering Profile.

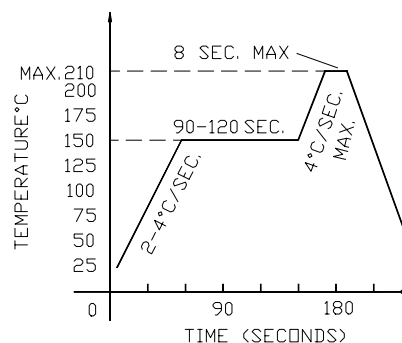

◎ Absolute Maximum Ratings:

Series	I _F (mA)	*I _{FP} (mA)	V _R (V)	T _{OP} (°C)	T _{ST} (°C)
GH-S170 Series	30	120	5	-20~+80	20~+100

*Condition for I_{FP} is pulse of 1/10 duty and 0.1msec width

* Optical Characteristic Curves Of GH-S170 Series

Rev : A Date : 2001/10/1

Relative Intensity vs. Wavelength

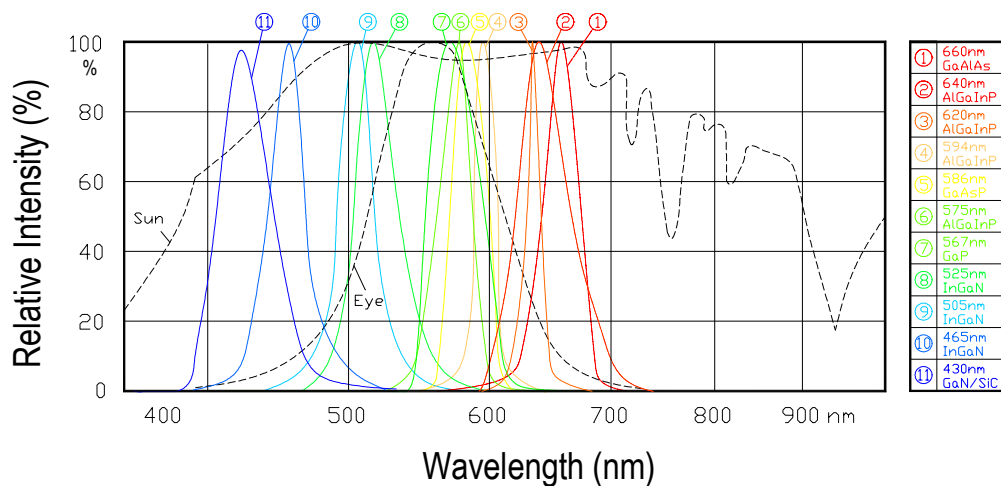

Forward Current vs. Forward Voltage

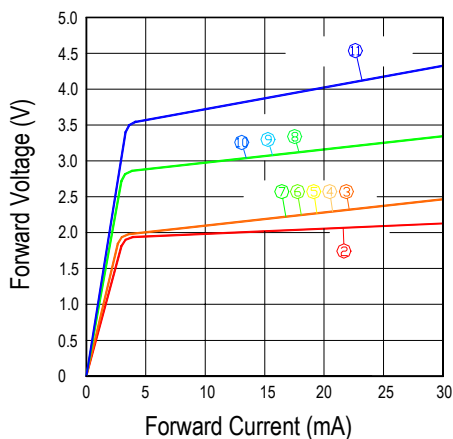

Relative Intensity vs. Forward Current

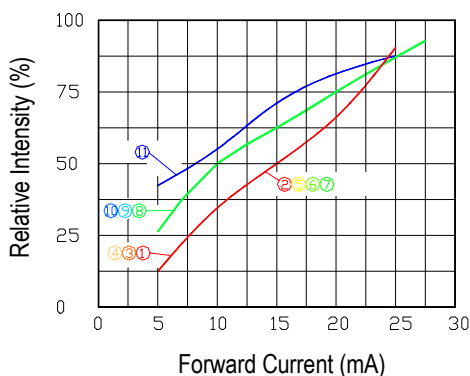

Directive Characteristics

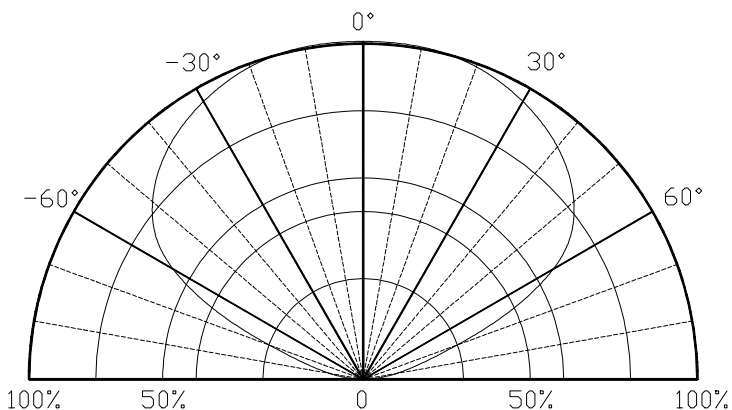

* Tape And Reel Of GH-S170 Series

Rev : A | Date : 2001/10/1

USER DIRECTION OF FEED

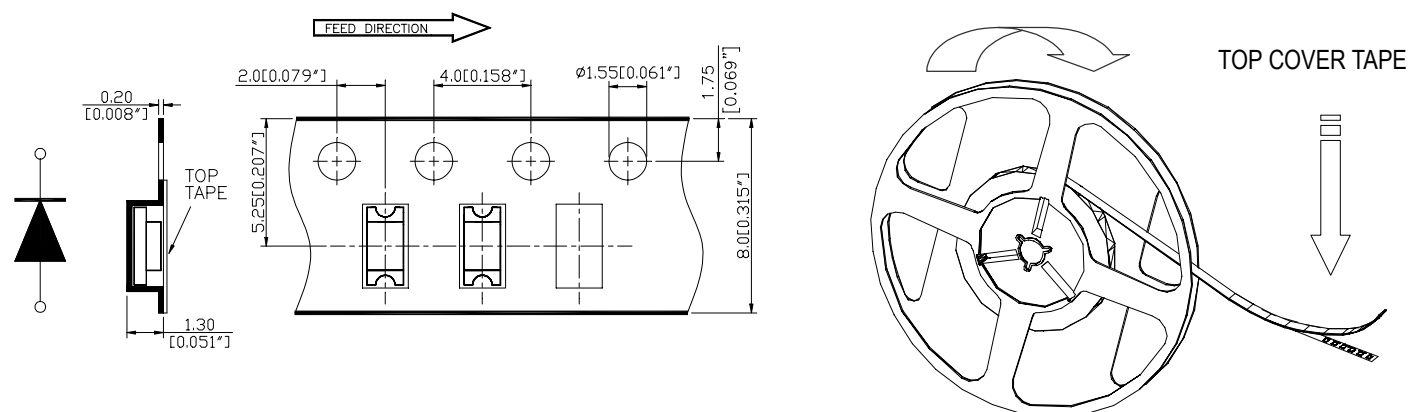

Dimensions per ANSI/EIA
Standard RS-481
All dimensions are in
millimeters (inches).

A	180[7.09]
B	60[2.36]
C	13.5[0.53]
W	8.4[0.33]

Thickness of top cover tape
0.1[0.004\"/>

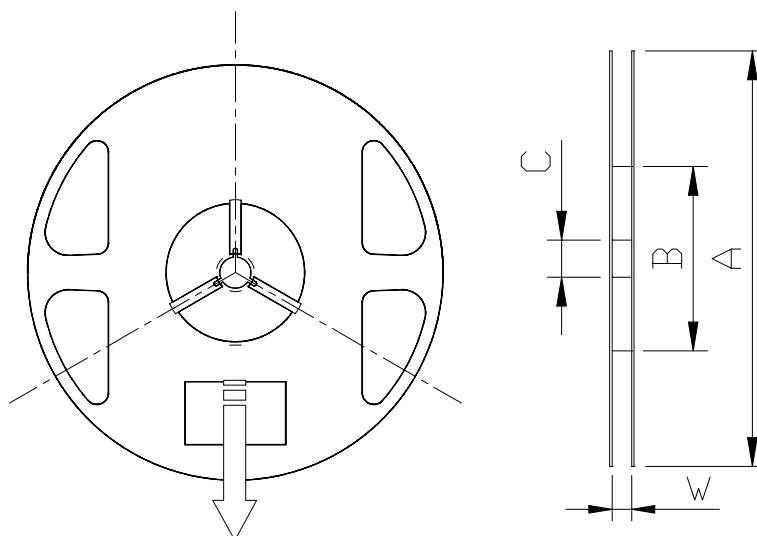

 GRAND HALO ELECTRONIC LTD	
PART NO.	
LOT NO.	
QUANTITY	
DATE	
DATA	

NOTES:

1. Empty component pockets are sealed with top cover tape;
2. Minimum leader length at both ends of the tape is 450 mm;
3. The maximum number of missing lamps is two;
4. The cathode is oriented towards the tape sprocket hole in accordance with ANSI/EIA RS-481 specifications.
5. 3000pcs/Reel