



## Triple 2:1 High-Speed Video Multiplexer

### FEATURES

- **700MHz SMALL-SIGNAL BANDWIDTH** ( $A_V = +2$ )
- **425MHz, 4V<sub>PP</sub> BANDWIDTH**
- **0.1dB GAIN FLATNESS to 150MHz**
- **4ns CHANNEL SWITCHING TIME**
- **LOW SWITCHING GLITCH: 40mV<sub>PP</sub>**
- **3100V/μs SLEW RATE**
- **0.025%/0.025° DIFFERENTIAL GAIN, PHASE**
- **HIGH GAIN ACCURACY: 2.0V/V ±0.4%**

### APPLICATIONS

- **RGB SWITCHING**
- **LCD PROJECTOR INPUT SELECT**
- **WORKSTATION GRAPHICS**
- **TRIPLE ADC INPUT MUX**
- **DROP-IN UPGRADE TO LT1675**

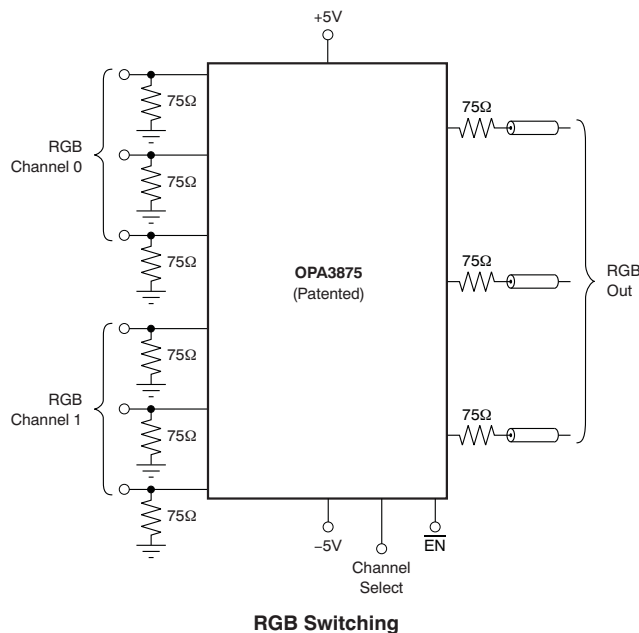

### DESCRIPTION

The OPA3875 offers a very wideband, 3-channel, 2:1 multiplexer in a small SSOP-16 package. Using only 11mA/ch, the OPA3875 provides three, gain of +2, video amplifier channels with > 400MHz large-signal bandwidth (4V<sub>PP</sub>). Gain accuracy and switching glitch are improved over earlier solutions using a new (patented) input stage switching approach. This technique uses current steering as the input switch while maintaining an overall closed-loop design. Gain matching between each of the 3-channel pairs is also significantly improved using this technique (<0.2% gain mismatch). With >700MHz small-signal bandwidth at a gain of 2, the OPA3875 gives a typical 0.1dB gain flatness to > 150MHz.

System power may be reduced using the chip enable feature for the OPA3875. Taking the chip enable line high powers down the OPA3875 to <900μA total supply current. Muxing multiple OPA3875 outputs together, then using the chip enable to select which channels are active, increases the number of possible inputs to the 3-channel outputs.

Where a single channel of the OPA3875 is required, consider the [OPA875](#).

OPA3875				
SELECT	ENABLE	RED OUT	GREEN OUT	BLUE OUT
1	0	R0	G0	B0
0	0	R1	G1	B1
X	1	Off	Off	Off

### OPA3875 RELATED PRODUCTS

	DESCRIPTION
<a href="#">OPA875</a>	Single-Channel OPA3875
<a href="#">OPA4872</a>	Quad 510MHz 4:1 Multiplexer
<a href="#">OPA3693</a>	Triple 650MHz Video Buffer



Please be aware that an important notice concerning availability, standard warranty, and use in critical applications of Texas Instruments semiconductor products and disclaimers thereto appears at the end of this data sheet.

All trademarks are the property of their respective owners.



This integrated circuit can be damaged by ESD. Texas Instruments recommends that all integrated circuits be handled with appropriate precautions. Failure to observe proper handling and installation procedures can cause damage.

ESD damage can range from subtle performance degradation to complete device failure. Precision integrated circuits may be more susceptible to damage because very small parametric changes could cause the device not to meet its published specifications.

**ORDERING INFORMATION<sup>(1)</sup>**

PRODUCT	PACKAGE-LEAD	PACKAGE DESIGNATOR	SPECIFIED TEMPERATURE RANGE	PACKAGE MARKING	ORDERING NUMBER	TRANSPORT MEDIA, QUANTITY
OPA3875	SSOP-16	DBQ	-45°C to +85°C	OP3875	OPA3875IDBQ	Rails, 75
					OPA3875IDBQR	Tape and Reel, 2500

(1) For the most current package and ordering information see the Package Option Addendum at the end of this document, or see the TI web site at [www.ti.com](http://www.ti.com).

**ABSOLUTE MAXIMUM RATINGS**

Over operating temperature range, unless otherwise noted.

	OPA3875	UNIT
Power Supply	±6.5	V
Internal Power Dissipation	See Thermal Analysis	
Input Voltage Range	±V <sub>S</sub>	V
Storage Temperature Range	-40 to +125	°C
Lead Temperature (soldering, 10s)	+260	°C
Operating Junction Temperature	+150	°C
Continuous Operating Junction Temperature	+140	°C
ESD Rating:		
Human Body Model (HBM)	2000	V
Charge Device Model (CDM)	1500	V
Machine Model (MM)	200	V

**PIN CONFIGURATION**

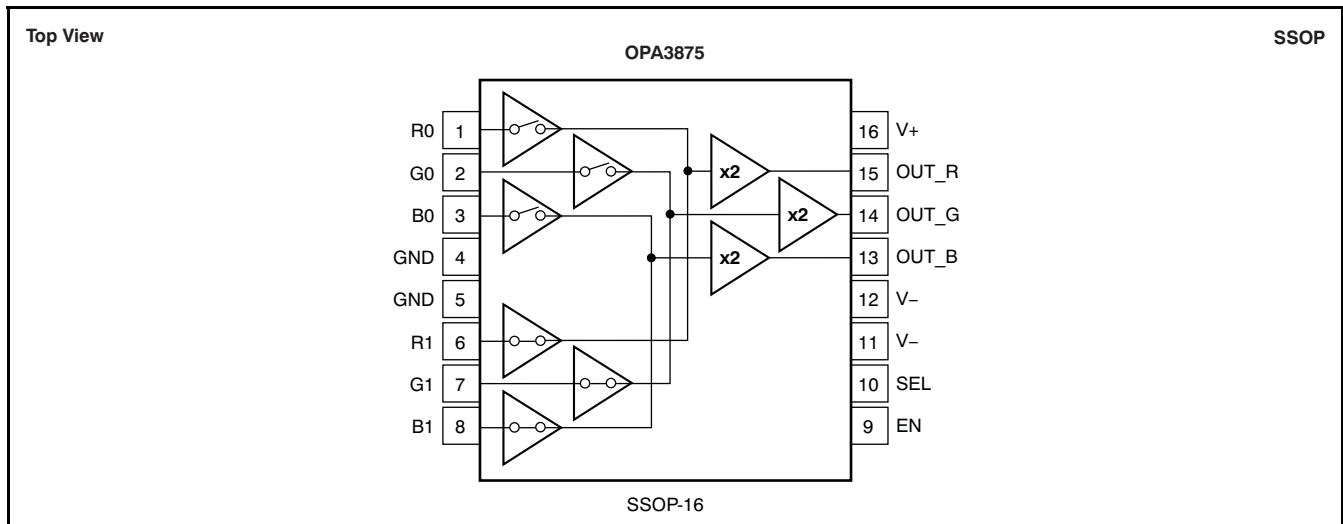

**ELECTRICAL CHARACTERISTICS:  $V_S = \pm 5V$**

At  $G = +2$ ,  $R_L = 150\Omega$ , unless otherwise noted.

PARAMETER	CONDITIONS	OPA3875				UNITS	MIN/ MAX	TEST LEVEL <sup>(1)</sup>
		TYP	MIN/MAX OVER TEMPERATURE					
		+25°C	+25°C <sup>(2)</sup>	0°C to 70°C <sup>(3)</sup>	–40°C to +85°C <sup>(3)</sup>			
<b>AC PERFORMANCE</b>								
	See Figure 1							
Small-Signal Bandwidth	$V_O = 200mV_{pp}$ , $R_L = 150\Omega$	700	525	515	505	MHz	min	B
Large-Signal Bandwidth	$V_O = 4V_{pp}$ , $R_L = 150\Omega$	425	390	380	370	MHz	min	B
Bandwidth for 0.1dB Gain Flatness	$V_O = 200mV_{pp}$	150				MHz	typ	C
Maximum Small-Signal Gain	$V_O = 200mV_{pp}$ , $R_L = 150\Omega$ , $f = 5MHz$	2.0	2.02	2.03	2.05	V/V	max	B
Minimum Small-Signal Gain	$V_O = 200mV_{pp}$ , $R_L = 150\Omega$ , $f = 5MHz$	2.0	1.98	1.97	1.95	V/V	min	B
SFDR	10MHz, $V_O = 2V_{pp}$ , $R_L = 150\Omega$	–68	–65	–64	–63	dBc	max	B
Input Voltage Noise	$f > 100kHz$	6.7	7.0	7.2	7.4	$nV/\sqrt{Hz}$	max	B
Input Current Noise	$f > 100kHz$	3.8	4.2	4.6	4.9	$pA/\sqrt{Hz}$	max	B
NTSC Differential Gain	$R_L = 150\Omega$	0.025				%	typ	C
NTSC Differential Phase	$R_L = 150\Omega$	0.025				°	typ	C
Slew Rate	$V_O = \pm 2V$	3100	2800	2700	2600	V/ $\mu s$	min	B
Rise Time and Fall Time	$V_O = 0.5V$ Step	460				ps	typ	C
	$V_O = 1.4V$ Step	600				ps	typ	C
<b>CHANNEL-TO-CHANNEL PERFORMANCE</b>								
Gain Match	Channel to Channel, $R_L = 150\Omega$	$\pm 0.05$	<b><math>\pm 0.25</math></b>	$\pm 0.3$	$\pm 0.35$	%	max	A
	All inputs, $R_L = 150\Omega$	$\pm 0.1$	<b><math>\pm 0.5</math></b>	$\pm 0.6$	$\pm 0.7$	%	max	A
Output Offset Voltage Mismatch	All three outputs	$\pm 3$	<b><math>\pm 9</math></b>	$\pm 10$	$\pm 12$	mV	max	A
All Hostile Crosstalk	$f = 50MHz$ , $R_L = 150\Omega$	–50				dB	typ	C
Channel-to-Channel Crosstalk	$f = 50MHz$ , $R_L = 150\Omega$	–58				dB	typ	C
<b>CHANNEL AND CHIP-SELECT PERFORMANCE</b>								
SEL (Channel Select) Switching Time	$R_L = 150\Omega$	4				ns	typ	C
$\overline{EN}$ (Chip Select) Switching Time	Turn On	9				ns	typ	C
	Turn Off	60				ns	typ	C
SEL (Channel Select) Switching Glitch	All Inputs to Ground, At Matched Load	40				$mV_{pp}$	typ	C
$\overline{EN}$ (Chip-Select) Switching Glitch	All Inputs to Ground, At Matched Load	15				$mV_{pp}$	typ	C
All Hostile Disable Feedthrough	50MHz, Chip Disabled ( $\overline{EN} = High$ )	–68				dB	typ	C
Maximum Logic 0	$\overline{EN}$ , SEL		0.8	0.8	0.8	V	max	B
Minimum Logic 1	$\overline{EN}$ , SEL		2.0	2.0	2.0	V	min	B
$\overline{EN}$ Logic Input Current	0V to 4.5V	75	<b>100</b>	125	150	$\mu A$	max	A
SEL Logic Input Current	0V to 4.5V	160	<b>200</b>	250	300	$\mu A$	max	A
<b>DC PERFORMANCE</b>								
Output Offset Voltage	$R_{IN} = 0\Omega$ , $G = +2V/V$	$\pm 2.5$	<b><math>\pm 14</math></b>	$\pm 15.8$	$\pm 17$	mV	max	A
Average Output Offset Voltage Drift	$R_{IN} = 0\Omega$ , $G = +2V/V$			$\pm 50$	$\pm 50$	$\mu V/^\circ C$	max	B
Input Bias Current		$\pm 5$	<b><math>\pm 18</math></b>	$\pm 19.5$	$\pm 20.5$	$\mu A$	max	A
Average Input Bias Current Drift				$\pm 40$	$\pm 40$	$nA/^\circ C$	max	B
Gain Error (from 2V/V)	$V_O = \pm 2V$	0.4	<b>1.4</b>	1.5	1.6	%	max	A
<b>INPUT</b>								
Input Voltage Range		$\pm 2.8$				V	typ	C
Input Resistance		1.75				$M\Omega$	typ	C
Input Capacitance	Channel Selected	0.9				pF	typ	C
	Channel Deselected	0.9				pF	typ	C
	Chip Disabled	0.9				pF	typ	C

- (1) Test levels: (A) 100% tested at +25°C. Over temperature limits set by characterization and simulation. (B) Limits set by characterization and simulation. (C) Typical value only for information.
- (2) Junction temperature = ambient at +25°C tested specifications.
- (3) Junction temperature = ambient at low temperature limit; junction temperature = ambient +36°C at high temperature limit for over temperature specifications.

**ELECTRICAL CHARACTERISTICS:  $V_S = \pm 5V$  (continued)**At  $G = +2$ ,  $R_L = 150\Omega$ , unless otherwise noted.

PARAMETER	CONDITIONS	OPA3875				UNITS	MIN/ MAX	TEST LEVEL <sup>(1)</sup>
		TYP	MIN/MAX OVER TEMPERATURE					
		+25°C	+25°C <sup>(2)</sup>	0°C to 70°C <sup>(3)</sup>	–40°C to +85°C <sup>(3)</sup>			
<b>OUTPUT</b>								
Output Voltage Range		±3.5	±3.4	±3.35	±3.3	V	min	A
Output Current	$V_O = 0V$ , Linear Operation	±70	±50	±45	±40	mA	min	A
Output Resistance	Chip enabled	0.3				Ω	typ	C
	Chip Disabled, Maximum	800	912	915	918	Ω	max	A
	Chip Disabled, Minimum	800	688	685	682	Ω	min	A
Output Capacitance	Chip Disabled	2				pF	typ	C
<b>POWER SUPPLY</b>								
Specified Operating Voltage		±5				V	typ	C
Minimum Operating Voltage			±3.0	±3.0	±3.0	V	min	B
Maximum Operating Voltage			±6.3	±6.3	±6.3	V	max	A
Maximum Quiescent Current	Chip Selected, $V_S = \pm 5V$	33	34	35	36	mA	max	A
Minimum Quiescent Current	Chip Selected, $V_S = \pm 5V$	33	31	30	27	mA	min	A
Maximum Quiescent Current	Chip Deselected	0.9	1.2	1.4	1.5	mA	max	A
Power-Supply Rejection Ratio	(+PSRR)							
	Input-Referred	56	50	48	47	dB	min	A
	(–PSRR)							
	Input-Referred	55	51	49	48	dB	min	A
<b>THERMAL CHARACTERISTICS</b>								
Specified Operating Range D Package		–40 to +85				°C	typ	C
Thermal Resistance $\theta_{JA}$	Junction-to-Ambient							
DBQ	SSOP-16	85				°C/W	typ	C

**TYPICAL CHARACTERISTICS:  $V_S = \pm 5V$**

At  $G = +2$  and  $R_L = 150\Omega$ , unless otherwise noted.

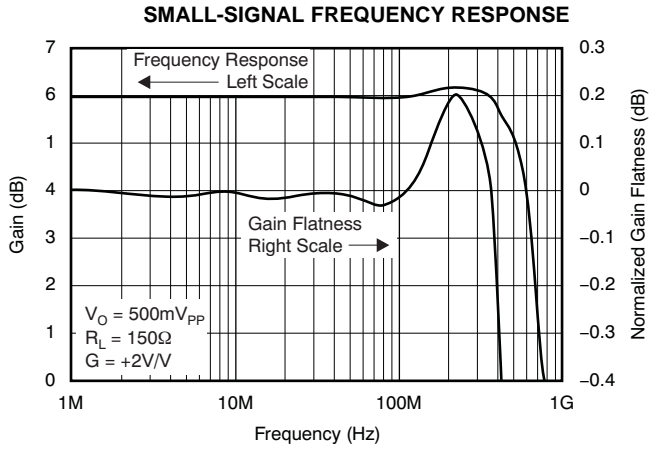

Figure 1.

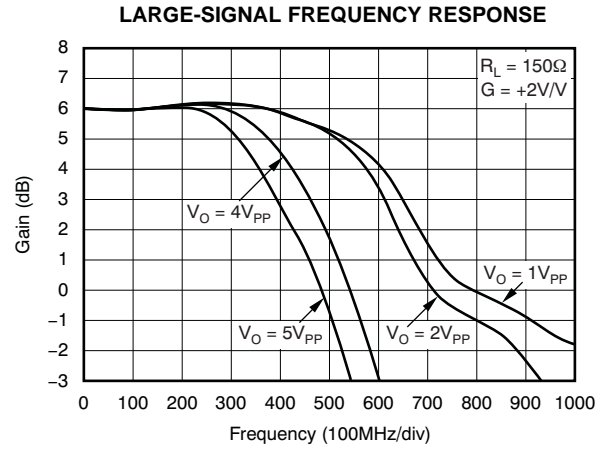

Figure 2.

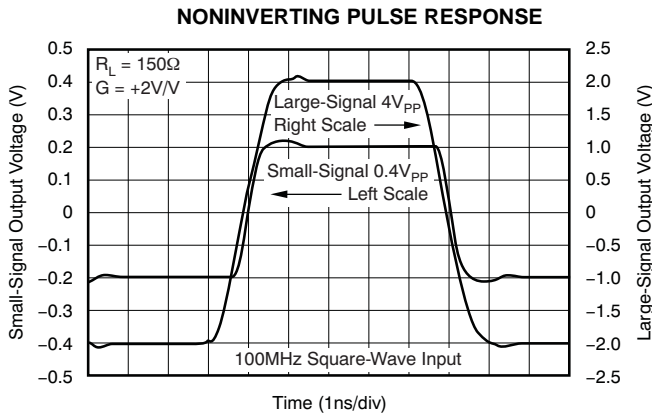

Figure 3.

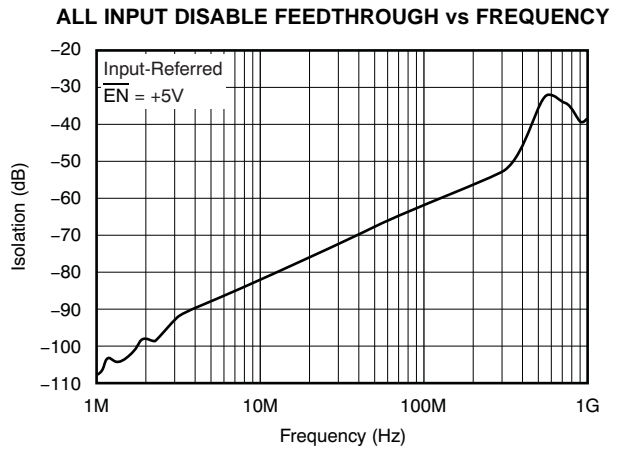

Figure 4.

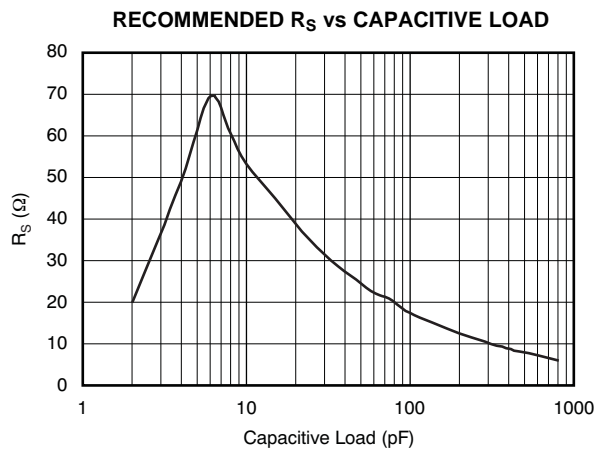

Figure 5.

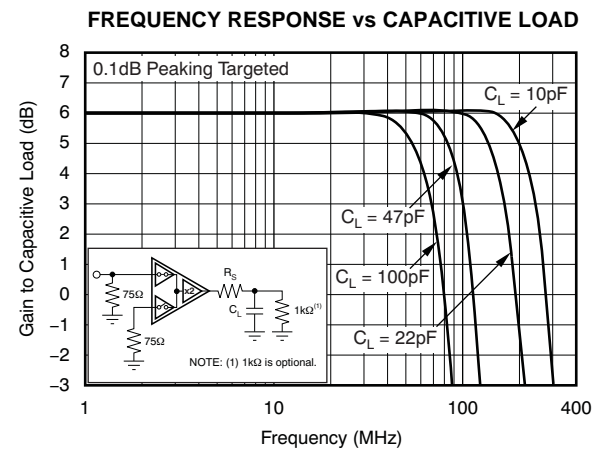

Figure 6.

**TYPICAL CHARACTERISTICS:  $V_S = \pm 5V$  (continued)**

At  $G = +2$  and  $R_L = 150\Omega$ , unless otherwise noted.

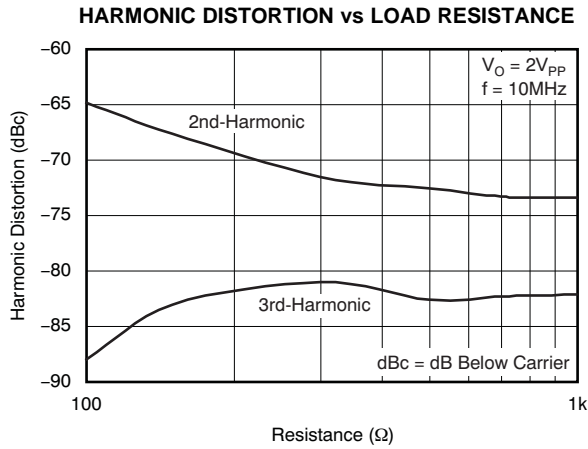

Figure 7.

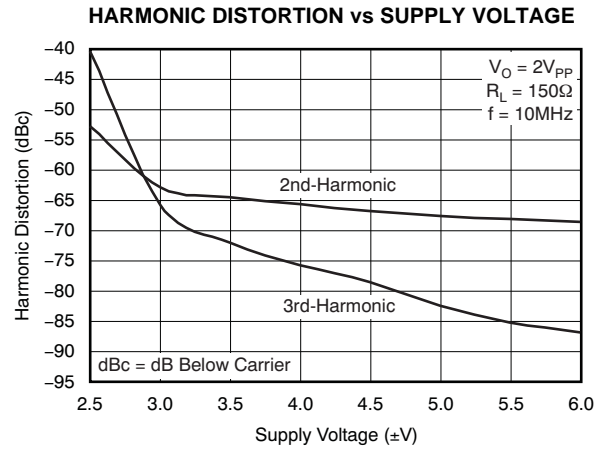

Figure 8.

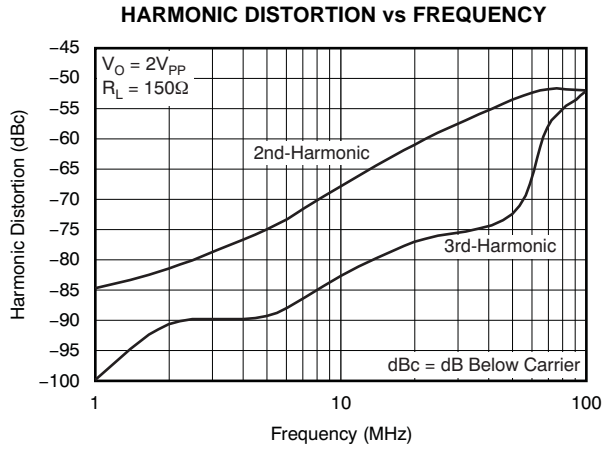

Figure 9.

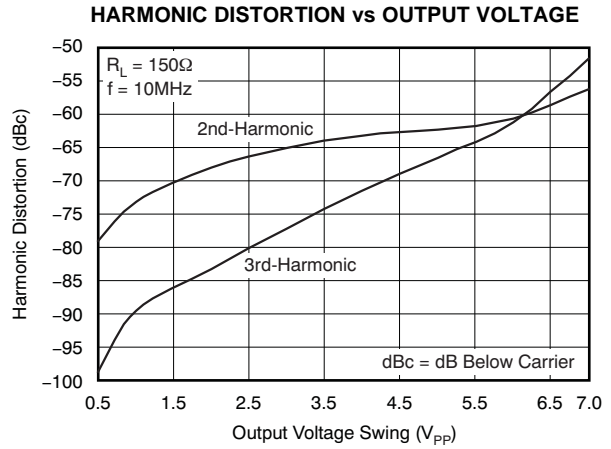

Figure 10.

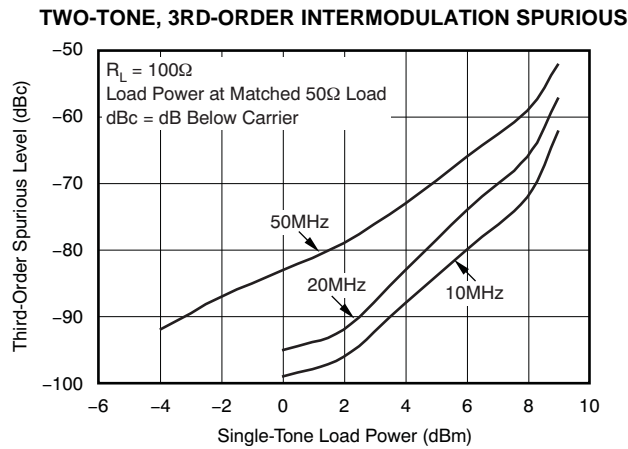

Figure 11.

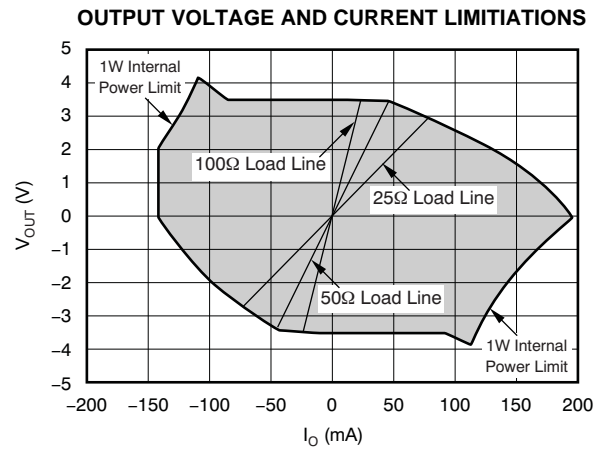

Figure 12.

**TYPICAL CHARACTERISTICS:  $V_S = \pm 5V$  (continued)**

At  $G = +2$  and  $R_L = 150\Omega$ , unless otherwise noted.

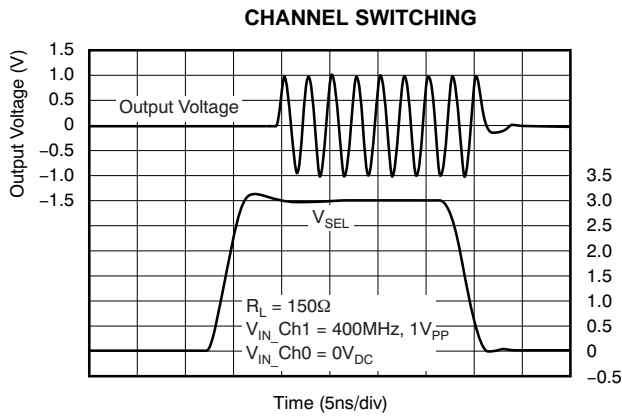

Figure 13.

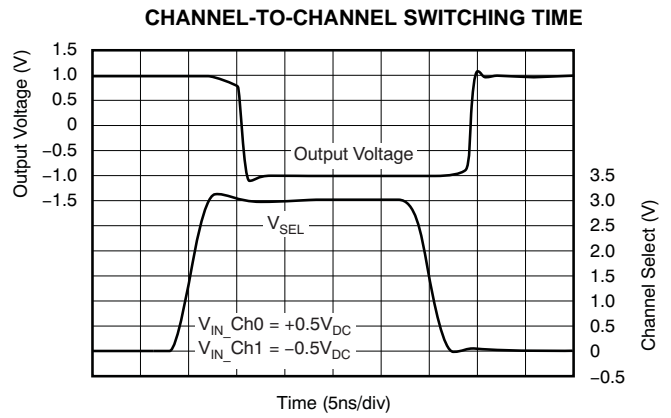

Figure 14.

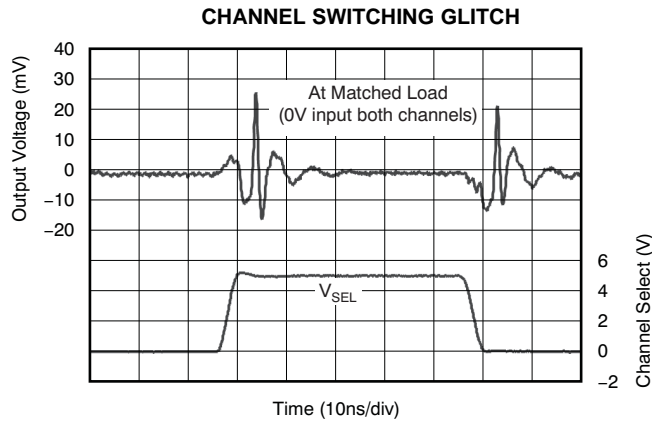

Figure 15.

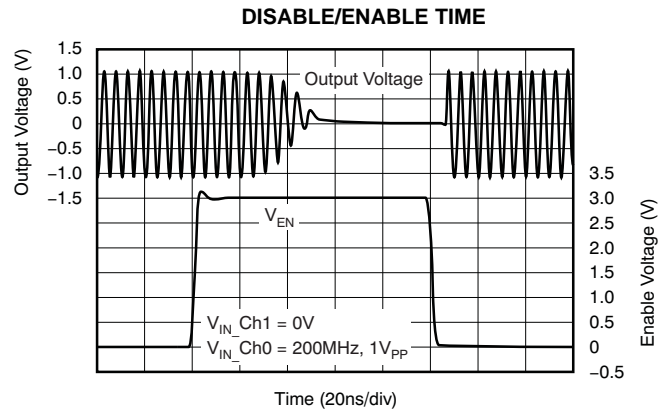

Figure 16.

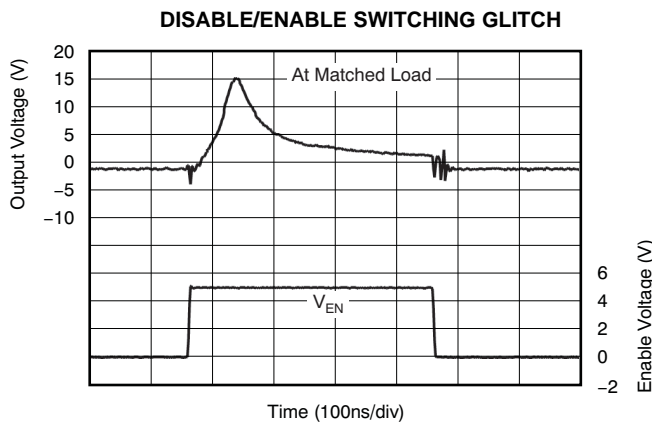

Figure 17.

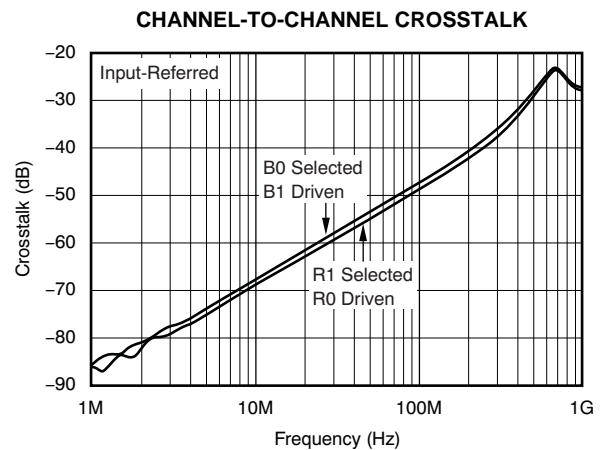

Figure 18.

**TYPICAL CHARACTERISTICS:  $V_S = \pm 5V$  (continued)**

At  $G = +2$  and  $R_L = 150\Omega$ , unless otherwise noted.

**ALL HOSTILE AND ADJACENT-CHANNEL CROSSTALK vs FREQUENCY**

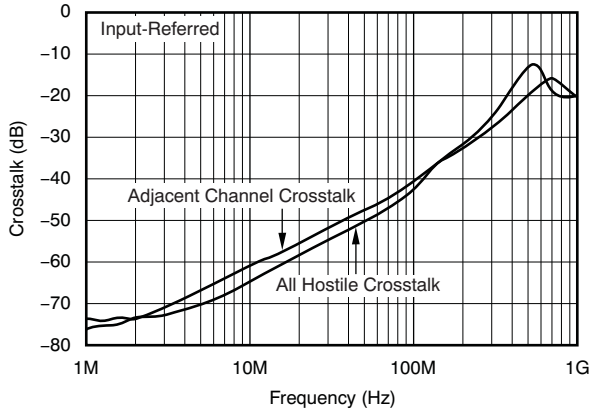

Figure 19.

**CLOSED-LOOP OUTPUT IMPEDANCE vs FREQUENCY**

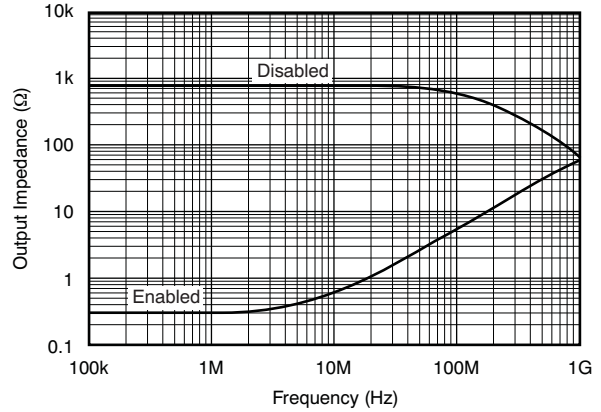

Figure 20.

**INPUT IMPEDANCE vs FREQUENCY**

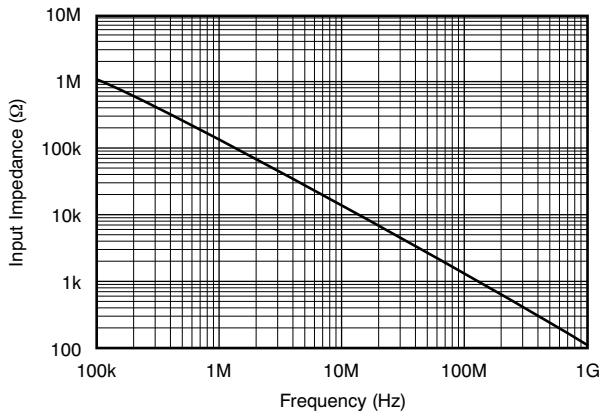

Figure 21.

**PSRR vs FREQUENCY**

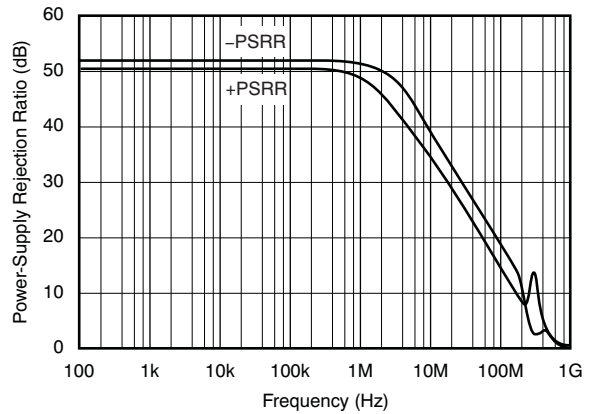

Figure 22.

**SUPPLY CURRENT vs TEMPERATURE**

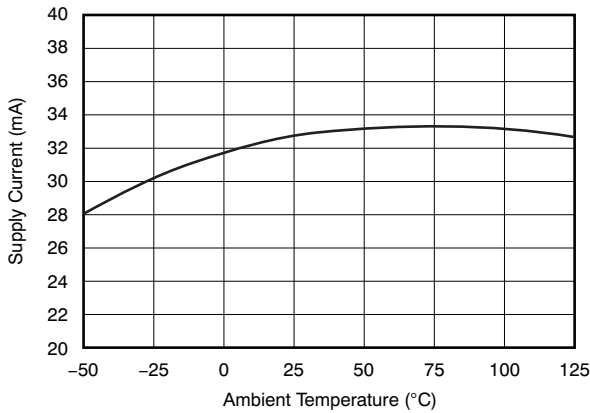

Figure 23.

**TYPICAL DC DRIFT OVER TEMPERATURE**

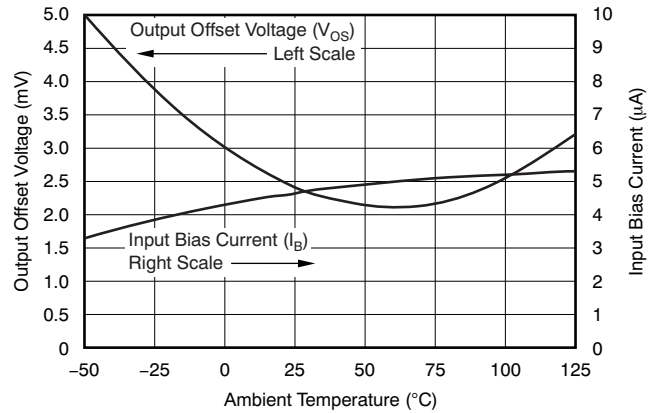
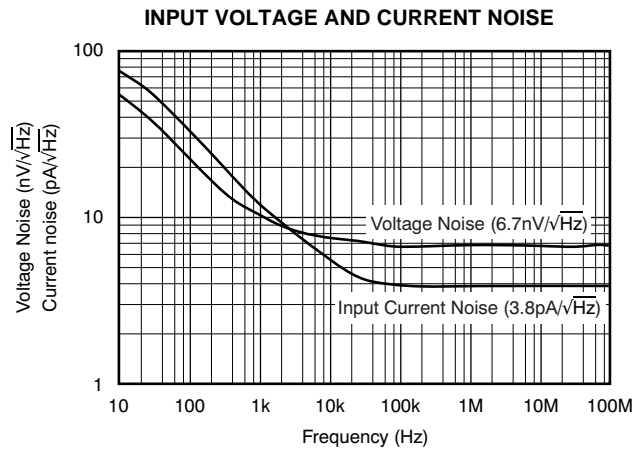

Figure 24.



**TYPICAL CHARACTERISTICS:  $V_S = \pm 5V$  (continued)**

At  $G = +2$  and  $R_L = 150\Omega$ , unless otherwise noted.



**Figure 25.**

## APPLICATIONS INFORMATION

### 2:1 HIGH-SPEED VIDEO MULTIPLEXER OPERATION

The OPA3875 can be used as a triple 2:1 high-speed video multiplexer, as illustrated in the front page schematic for an RGB signal. Figure 26 shows a simplified version of the front page schematic in which one output is shown with its input and output impedance matching resistors.

### RGB VIDEO INVERTER

Figure 27 illustrates an extension of the previously shown RGB switching circuit with a noninverting signal going through channel 1 and an inverted signal going through channel two. Here, the output impedance of the OPA3875 is set to  $75\Omega$ . Looking at the input part of this circuit, we see that the RGB signal is inverted with an OPA3693 fixed gain set in an inverting configuration with a reference voltage on the noninverting node. The reference voltage, set here at  $0.714\text{V}$ , has a gain of 1 at the output of the OPA3691 as the input signal is AC-coupled (not represented here). This bias voltage is required to prevent the video from swinging negative. Note also

that the  $75\Omega$  input matching impedance is set here by the parallel combination of  $92\Omega$  and  $402\Omega$ . In order not to disturb the sync, color burst, and blanking if present, the inverting amplifiers are only switched on during active video.

### LOGO INSERTER

Figure 28 illustrates the principle of overlaying a picture in a picture. The picture comes through U1; the signal to be overlaid comes through U2. Here we have a reference voltage of  $0.714\text{V}$  in channel 2 indicating that we will highlight a section of the picture with white (for NTSC-related RGB video). How much white comes through depends on the combination of select 1 and select 2 pins as well as the series output resistance of each OPA3875. To match the  $75\Omega$  output impedance of the video cable, the parallel combination of the series output resistance ( $R$  and  $nR$ ) needs to be  $75\Omega$ . The two select pins gives us 2 bits of control. By selecting  $n = 2$ , you have the capability of a 0% highlight (full original video signal), 33% highlight, 66% highlight, and 100% highlight (all white). By selecting  $n = 3$ , you have 0%, 25%, 75%, and 100% highlight capabilities, etc.

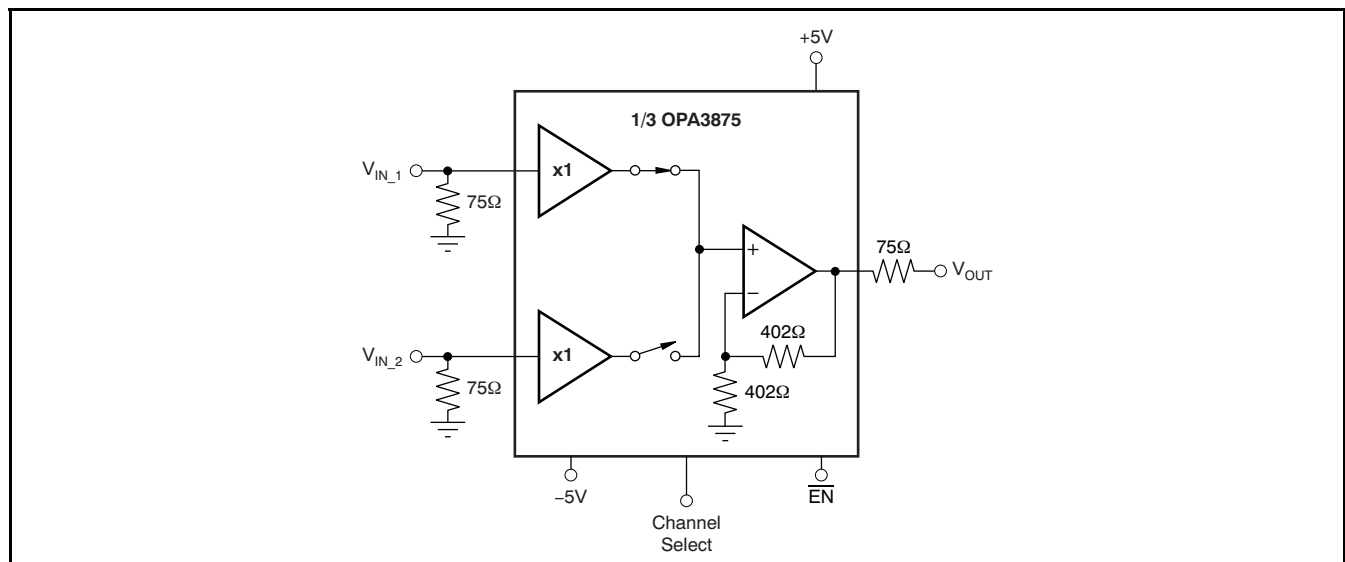
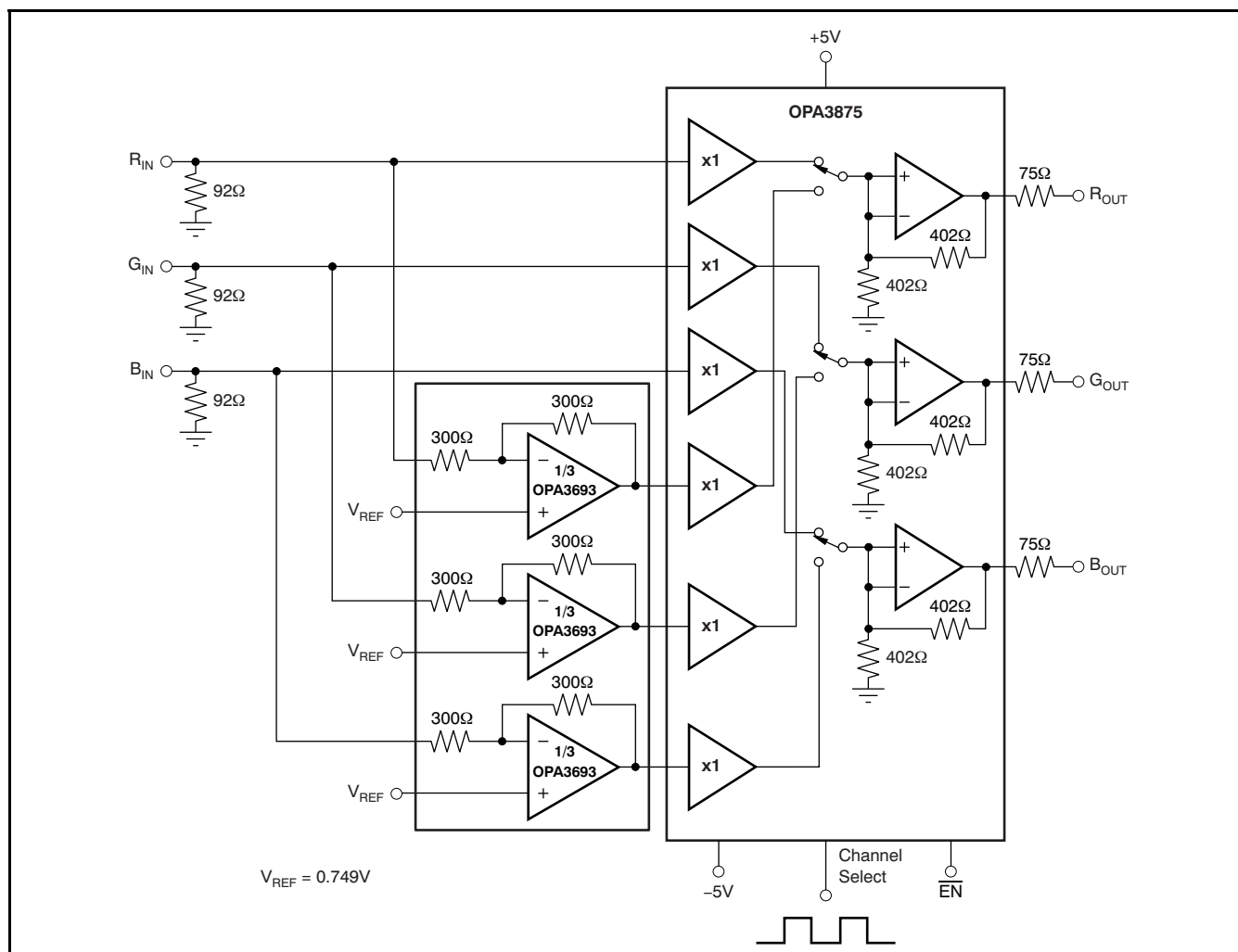

Figure 26. Triple 2:1 High-Speed Video Multiplexer



**Figure 27. RGB Video Inverter**

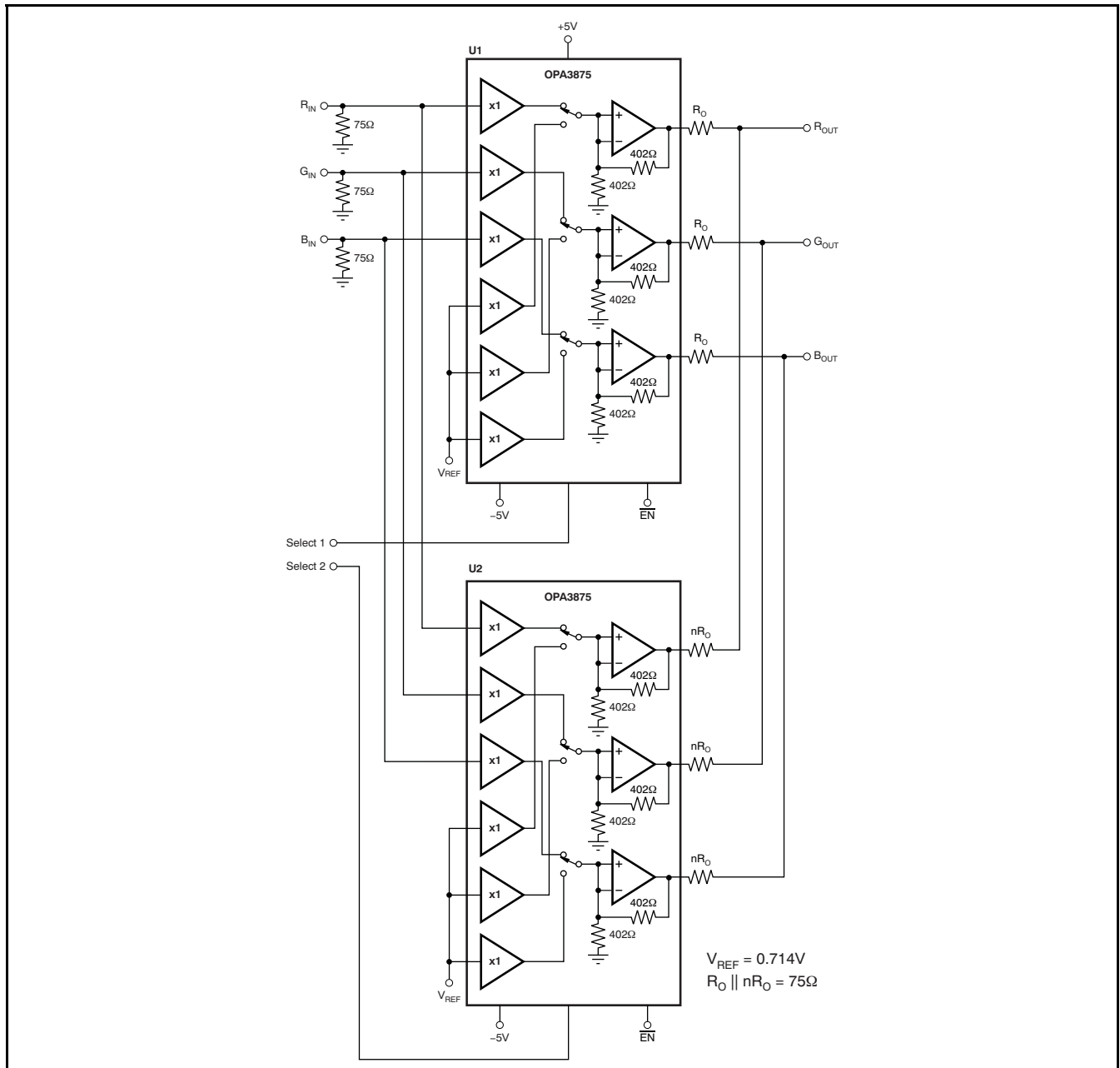

Figure 28. Logo Inserter

## ADC INPUT MUX

Figure 29 shows the OPA3875 used as a multiplexer in a high-speed data acquisition signal chain.

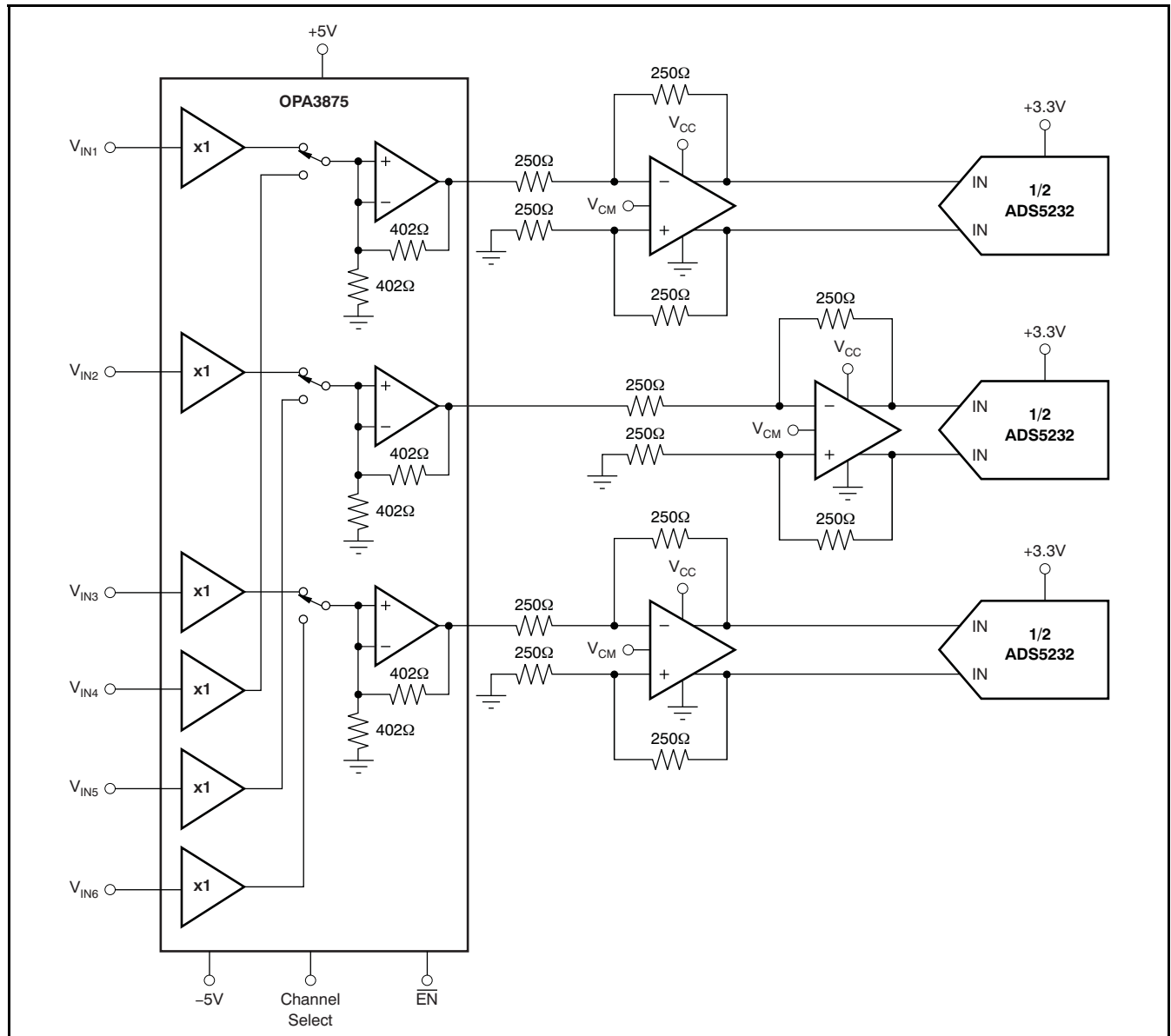

Figure 29. ADC Input Multiplexer

## DESIGN-IN TOOLS

### DEMONSTRATION FIXTURES

A printed circuit board (PCB) is available to assist in the initial evaluation of circuit performance using the OPA3875. The fixture is offered free of charge as an unpopulated PCB, delivered with a user's guide. The summary information for this fixture is shown in [Table 1](#).

**Table 1. OPA3875 Demonstration Fixture**

PRODUCT	PACKAGE	ORDERING NUMBER	LITERATURE NUMBER
OPA3875IDBQ	SSOP-16	DEM-TIV-SSOP-3A	SBOU043

The demonstration fixture can be requested at the Texas Instruments web site at ([www.ti.com](http://www.ti.com)) through the OPA3875 product folder.

### MACROMODELS AND APPLICATIONS SUPPORT

Computer simulation of circuit performance using SPICE is often useful when analyzing the performance of analog circuits and systems. This is particularly true for video and RF amplifier circuits where parasitic capacitance and inductance can have a major effect on circuit performance. A SPICE model for the OPA875 is available through the Texas Instruments web site at [www.ti.com](http://www.ti.com). Use three of these models to simulate the OPA3875. These models do a good job of predicting small-signal AC and transient performance under a wide variety of operating conditions. They do not do as well in predicting the harmonic distortion or dG/dP characteristics. These models do not attempt to distinguish between the package types in their small-signal AC performance nor do they predict channel-to-channel effects.

### OPERATING SUGGESTIONS

#### DRIVING CAPACITIVE LOADS

One of the most demanding, yet very common load conditions is capacitive loading. Often, the capacitive load is the input of an ADC—including additional external capacitance that may be recommended to improve ADC linearity. A high-speed device such as the OPA3875 can be very susceptible to decreased stability and closed-loop response peaking when a capacitive load is placed directly on the output pin. When the device open-loop output resistance is considered, this capacitive load introduces an additional pole in the signal path that can decrease

the phase margin. Several external solutions to this problem have been suggested. When the primary considerations are frequency response flatness, pulse response fidelity, and/or distortion, the simplest and most effective solution is to isolate the capacitive load from the feedback loop by inserting a series isolation resistor between the amplifier output and the capacitive load. This isolation resistor does not eliminate the pole from the loop response, but rather shifts it and adds a zero at a higher frequency. The additional zero acts to cancel the phase lag from the capacitive load pole, thus increasing the phase margin and improving stability.

The [Typical Characteristics](#) show the recommended  $R_S$  versus capacitive load and the resulting frequency response at the load; see [Figure 5](#) and [Figure 6](#), respectively. Parasitic capacitive loads greater than 2pF can begin to degrade the performance of the OPA3875. Long PCB traces, unmatched cables, and connections to multiple devices can easily cause this value to be exceeded. Always consider this effect carefully, and add the recommended series resistor as close as possible to the OPA3875 output pin (see the [Board Layout Guidelines](#) section).

### DC ACCURACY

The OPA3875 offers excellent DC signal accuracy. Parameters that influence the output DC offset voltage are:

- Output offset voltage
- Input bias current
- Gain error
- Power-supply rejection ratio
- Temperature

Leaving both temperature and gain error parameters aside, the output offset voltage envelope can be described as shown in [Equation 1](#):

$$V_{OSO\_envelope} = V_{OSO} + (R_S \cdot I_b) \times G \pm \left[ 5 - (V_{S+}) \right] \times 10^{-\frac{PSRR+}{20}} \pm \left[ -5 - (V_{S+}) \right] \times 10^{-\frac{PSRR-}{20}} + V_{CM} \times 10^{-\frac{CMRR}{20}}$$

With:

- $V_{OSO}$ : Output offset voltage
- $R_S$ : Input resistance seen by R0, R1, G0, G1, B0, or B1.
- $I_b$ : Input bias current
- $G$ : Gain
- $V_{S+}$ : Positive supply voltage
- $V_{S-}$ : Negative supply voltage
- $PSRR+$ : Positive supply PSRR
- $PSRR-$ : Negative supply PSRR

Evaluating the front-page schematic, using a worst-case, +25°C offset voltage, bias current and PSRR specifications and operating at ±6V, gives a worst-case output equal to Equation 2:

$$\begin{aligned} & \pm 14\text{mV} + 75\Omega \times \pm 18\mu\text{A} \times 2 \pm \left| 5 - 6 \right| \times 10^{-\frac{50}{20}} \\ & \pm \left| -5 - (-6) \right| \times 10^{-\frac{51}{20}} \\ & = \pm 22.7\text{mV} \end{aligned}$$

## DISTORTION PERFORMANCE

The OPA3875 provides good distortion performance into a 100Ω load on ±5V supplies. Relative to alternative solutions, it provides exceptional performance into lighter loads. Generally, until the fundamental signal reaches very high frequency or power levels, the 2nd-harmonic dominates the distortion with a negligible 3rd-harmonic component. Focusing then on the 2nd-harmonic, increasing the load impedance improves distortion directly. Also, providing an additional supply decoupling capacitor (0.01μF) between the supply pins (for bipolar operation) improves the 2nd-order distortion slightly (3dB to 6dB).

In most op amps, increasing the output voltage swing increases harmonic distortion directly. The Typical Characteristics show the 2nd-harmonic increasing at a little less than the expected 2X rate while the 3rd-harmonic increases at a little less than the expected 3X rate. Where the test power doubles, the 2nd-harmonic increases only by less than the expected 6dB, whereas the 3rd-harmonic increases by less than the expected 12dB. This also shows up in the two-tone, 3rd-order intermodulation spurious (IM3) response curves. The 3rd-order spurious levels are extremely low at low output power levels. The output stage continues to hold them low even as the fundamental power reaches very high levels. As the Typical Characteristics show, the spurious intermodulation powers do not increase as predicted by a traditional intercept model. As the fundamental power level increases, the dynamic range does not decrease significantly. For two tones centered at 20MHz, with 4dBm/tone into a matched 50Ω load (that is, 1V<sub>PP</sub> for each tone at the load, which requires 4V<sub>PP</sub> for the overall 2-tone envelope at the output pin), the Typical Characteristics show a 82dBc difference between the test-tone power and the 3rd-order intermodulation spurious levels.

## NOISE PERFORMANCE

The OPA3875 offers an excellent balance between voltage and current noise terms to achieve low output noise. As long as the AC source impedance looking out of the noninverting node is less than 100Ω, this current noise will not contribute significantly to the total output noise. Figure 30 shows this device noise analysis model with all the noise terms included. In this model, all noise terms are taken to be noise voltage or current density terms in either nV/√Hz or pA/√Hz.

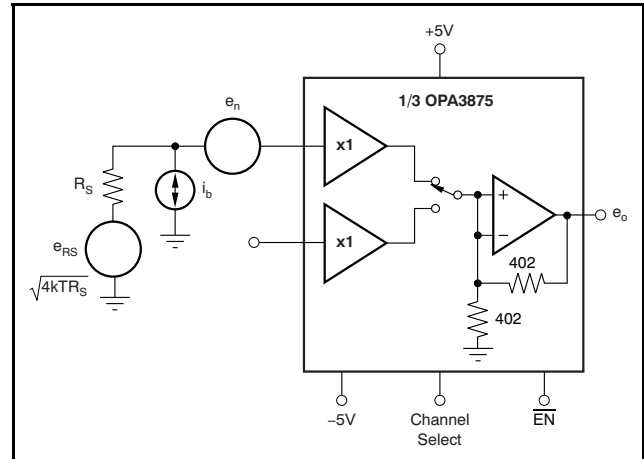

Figure 30. Noise Model

The total output spot noise voltage can be computed as the square root of the sum of all squared output noise voltage contributors. Equation 3 shows the general form for the output noise voltage using the terms shown in Figure 30.

$$e_o = 2 \sqrt{e_n^2 + (i_b R_S)^2 + 4kTR_S}$$

Dividing this expression by the device gain (2V/V) gives the equivalent input-referred spot noise voltage at the noninverting input as shown in Equation 4.

$$e_n = \sqrt{e_n^2 + (i_b R_S)^2 + 4kTR_S}$$

Evaluating these two equations for the OPA3875 circuit and component values shown in Figure 26 gives a total output spot noise voltage of 13.6nV/√Hz and a total equivalent input spot noise voltage of 6.8nV/√Hz. This total input-referred spot noise voltage is higher than the 6.7nV/√Hz specification for the mux voltage noise alone. This number reflects the noise added to the output by the bias current noise times the source resistor.

## THERMAL ANALYSIS

Heatsinking or forced airflow may be required under extreme operating conditions. Maximum desired junction temperature will set the maximum allowed internal power dissipation as discussed in this document. In no case should the maximum junction temperature be allowed to exceed +150°C.

Operating junction temperature ( $T_J$ ) is given by  $T_A + P_D \times \theta_{JA}$ . The total internal power dissipation ( $P_D$ ) is the sum of quiescent power ( $P_{DQ}$ ) and additional power dissipated in the output stage ( $P_{DL}$ ) to deliver load power. Quiescent power is simply the specified no-load supply current times the total supply voltage across the part.  $P_{DL}$  depends on the required output signal and load but, for a grounded resistive load, is at a maximum when the output is fixed at a voltage equal to 1/2 of either supply voltage (for equal bipolar supplies). Under this condition  $P_{DL} = V_S^2 / (4 \times R_L)$ , where  $R_L$  includes feedback network loading.

Note that it is the power in the output stage and not in the load that determines internal power dissipation.

As a worst-case example, compute the maximum  $T_J$  using an OPA3875 in the circuit of [Figure 26](#) operating at the maximum specified ambient temperature of +85°C with all three outputs driving a grounded 100Ω load to +2.5V:

$$P_D = 10V \times 36mA + 3(5^2/4 \times (100\Omega \parallel 804\Omega)) = 571mW$$

$$\text{Maximum } T_J = +85^\circ\text{C} + (0.57W \times 85^\circ\text{C/W}) = 133^\circ\text{C}$$

This worst-case condition is approaching the maximum +150°C junction temperature. Normally, this extreme case is not encountered. Careful attention to internal power dissipation is required.

## BOARD LAYOUT GUIDELINES

Achieving optimum performance with a high frequency amplifier such as the OPA3875 requires careful attention to board layout parasitics and external component types. Recommendations that will optimize performance include:

**a) Minimize parasitic capacitance to any AC ground for all of the signal I/O pins.** Parasitic capacitance on the output pin can cause instability: on the noninverting input, it can react with the source impedance to cause unintentional bandlimiting. To reduce unwanted capacitance, a window around the signal I/O pins should be opened in all of the ground and power planes around those pins. Otherwise, ground and power planes should be unbroken elsewhere on the board.

**b) Minimize the distance (< 0.25") from the power-supply pins to high frequency 0.1μF decoupling capacitors.** At the device pins, the ground and power plane layout should not be in close proximity to the signal I/O pins. Avoid narrow power and ground traces to minimize inductance between the pins and the decoupling capacitors. The power-supply connections (on pins 9, 11, 13, and 15) should always be decoupled with these capacitors. An optional supply decoupling capacitor across the two power supplies (for bipolar operation) will improve 2nd-harmonic distortion performance. Larger (2.2μF to 6.8μF) decoupling capacitors, effective at lower frequency, should also be used on the main supply pins. These may be placed somewhat farther from the device and may be shared among several devices in the same area of the PCB.

**c) Careful selection and placement of external components will preserve the high-frequency performance of the OPA3875.** Resistors should be a very low reactance type. Surface-mount resistors work best and allow a tighter overall layout. Metal-film and carbon composition, axially leaded resistors can also provide good high-frequency performance. Again, keep their leads and PCB trace length as short as possible. Never use wirewound type resistors in a high-frequency application. Other network components, such as noninverting input termination resistors, should also be placed close to the package.

**d) Connections to other wideband devices on the board may be made with short direct traces or through onboard transmission lines.** For short connections, consider the trace and the input to the next device as a lumped capacitive load. Relatively wide traces (50mils to 100mils) should be used, preferably with ground and power planes opened up around them. Estimate the total capacitive load and set  $R_S$  from the plot of [Figure 5](#). Low parasitic capacitive loads (< 5pF) may not need an  $R_S$  because the OPA3875 is nominally compensated to operate with a 2pF parasitic load. If a long trace is required, and the 6dB signal loss intrinsic to a doubly-terminated transmission line is acceptable, implement a matched impedance transmission line using microstrip or stripline techniques (consult an ECL design handbook for microstrip and stripline layout techniques). A 50Ω environment is normally not necessary on board, and in fact, a higher impedance environment will improve distortion as shown in the Distortion versus Load plots.



With a characteristic board trace impedance defined based on board material and trace dimensions, a matching series resistor into the trace from the output of the OPA3875 is used as well as a terminating shunt resistor at the input of the destination device. Remember also that the terminating impedance will be the parallel combination of the shunt resistor and the input impedance of the destination device; this total effective impedance should be set to match the trace impedance. The high output voltage and current capability of the OPA3875 allows multiple destination devices to be handled as separate transmission lines, each with their own series and shunt terminations. If the 6dB attenuation of a doubly-terminated transmission line is unacceptable, a long trace can be series-terminated at the source end only. Treat the trace as a capacitive load in this case and set the series resistor value as shown in [Figure 5](#). This will not preserve signal integrity as well as a doubly-terminated line. If the input impedance of the destination device is low, there will be some signal attenuation due to the voltage divider formed by the series output into the terminating impedance.

**e) Socketing a high-speed part like the OPA3875 is not recommended.** The additional lead length and pin-to-pin capacitance introduced by the socket can create an extremely troublesome parasitic network which can make it almost impossible to achieve a smooth, stable frequency response. Best results are obtained by soldering the OPA3875 onto the board.

## INPUT AND ESD PROTECTION

The OPA3875 is built using a very high-speed complementary bipolar process. The internal junction breakdown voltages are relatively low for these very small geometry devices. These breakdowns are reflected in the [Absolute Maximum Ratings](#) table. All device pins have limited ESD protection using internal diodes to the power supplies as shown in [Figure 31](#).

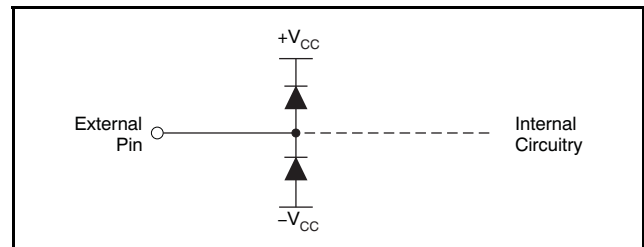

**Figure 31. Internal ESD Protection**

These diodes provide moderate protection to input overdrive voltages above the supplies as well. The protection diodes can typically support 30mA continuous current. Where higher currents are possible (for example, in systems with  $\pm 15V$  supply parts driving into the OPA3875), current-limiting series resistors should be added into the two inputs. Keep these resistor values as low as possible because high values degrade both noise performance and frequency response.

**PACKAGING INFORMATION**

Orderable Device	Status <sup>(1)</sup>	Package Type	Package Drawing	Pins	Package Qty	Eco Plan <sup>(2)</sup>	Lead/Ball Finish	MSL Peak Temp <sup>(3)</sup>
OPA3875IDBQ	ACTIVE	SSOP/ QSOP	DBQ	16	75	Green (RoHS & no Sb/Br)	CU NIPDAU	Level-2-260C-1 YEAR
OPA3875IDBQG4	ACTIVE	SSOP/ QSOP	DBQ	16	75	Green (RoHS & no Sb/Br)	CU NIPDAU	Level-2-260C-1 YEAR
OPA3875IDBQR	ACTIVE	SSOP/ QSOP	DBQ	16	2500	Green (RoHS & no Sb/Br)	CU NIPDAU	Level-2-260C-1 YEAR
OPA3875IDBQRG4	ACTIVE	SSOP/ QSOP	DBQ	16	2500	Green (RoHS & no Sb/Br)	CU NIPDAU	Level-2-260C-1 YEAR

<sup>(1)</sup> The marketing status values are defined as follows:

**ACTIVE:** Product device recommended for new designs.

**LIFEBUY:** TI has announced that the device will be discontinued, and a lifetime-buy period is in effect.

**NRND:** Not recommended for new designs. Device is in production to support existing customers, but TI does not recommend using this part in a new design.

**PREVIEW:** Device has been announced but is not in production. Samples may or may not be available.

**OBSOLETE:** TI has discontinued the production of the device.

<sup>(2)</sup> Eco Plan - The planned eco-friendly classification: Pb-Free (RoHS), Pb-Free (RoHS Exempt), or Green (RoHS & no Sb/Br) - please check <http://www.ti.com/productcontent> for the latest availability information and additional product content details.

**TBD:** The Pb-Free/Green conversion plan has not been defined.

**Pb-Free (RoHS):** TI's terms "Lead-Free" or "Pb-Free" mean semiconductor products that are compatible with the current RoHS requirements for all 6 substances, including the requirement that lead not exceed 0.1% by weight in homogeneous materials. Where designed to be soldered at high temperatures, TI Pb-Free products are suitable for use in specified lead-free processes.

**Pb-Free (RoHS Exempt):** This component has a RoHS exemption for either 1) lead-based flip-chip solder bumps used between the die and package, or 2) lead-based die adhesive used between the die and leadframe. The component is otherwise considered Pb-Free (RoHS compatible) as defined above.

**Green (RoHS & no Sb/Br):** TI defines "Green" to mean Pb-Free (RoHS compatible), and free of Bromine (Br) and Antimony (Sb) based flame retardants (Br or Sb do not exceed 0.1% by weight in homogeneous material)

<sup>(3)</sup> MSL, Peak Temp. -- The Moisture Sensitivity Level rating according to the JEDEC industry standard classifications, and peak solder temperature.

**Important Information and Disclaimer:**The information provided on this page represents TI's knowledge and belief as of the date that it is provided. TI bases its knowledge and belief on information provided by third parties, and makes no representation or warranty as to the accuracy of such information. Efforts are underway to better integrate information from third parties. TI has taken and continues to take reasonable steps to provide representative and accurate information but may not have conducted destructive testing or chemical analysis on incoming materials and chemicals. TI and TI suppliers consider certain information to be proprietary, and thus CAS numbers and other limited information may not be available for release.

In no event shall TI's liability arising out of such information exceed the total purchase price of the TI part(s) at issue in this document sold by TI to Customer on an annual basis.

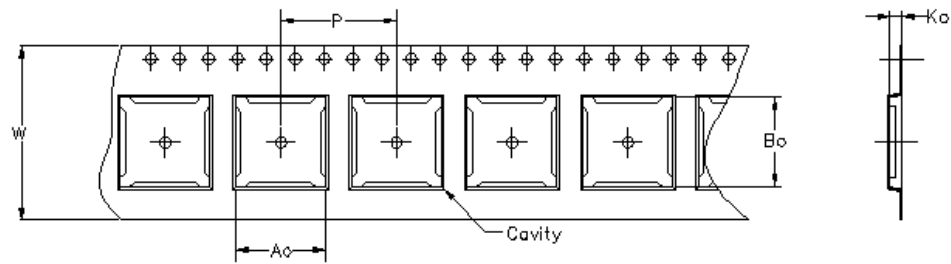

Carrier tape design is defined largely by the component length, width, and thickness.

$A_o$ = Dimension designed to accommodate the component width.
$B_o$ = Dimension designed to accommodate the component length.
$K_o$ = Dimension designed to accommodate the component thickness.
$W$ = Overall width of the carrier tape.
$P$ = Pitch between successive cavity centers.

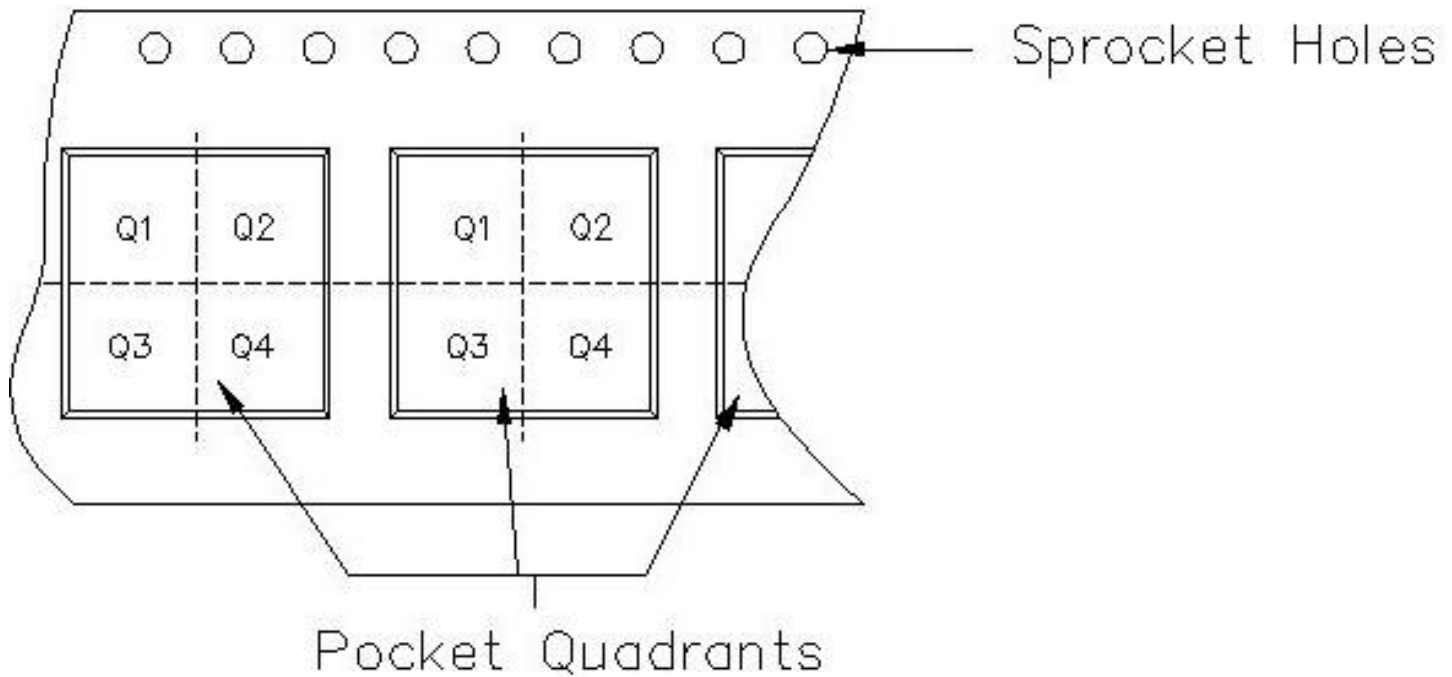

**TAPE AND REEL INFORMATION**

Device	Package	Pins	Site	Reel Diameter (mm)	Reel Width (mm)	A0 (mm)	B0 (mm)	K0 (mm)	P1 (mm)	W (mm)	Pin1 Quadrant
OPA3875IDBQR	DBQ	16	MLA	330	12	6.4	5.2	2.1	8	12	PKGORN T1TR-MS P

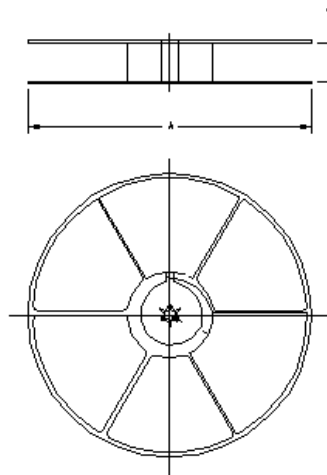

**TAPE AND REEL BOX INFORMATION**

Device	Package	Pins	Site	Length (mm)	Width (mm)	Height (mm)
OPA3875IDBQR	DBQ	16	MLA	390.0	348.0	63.0

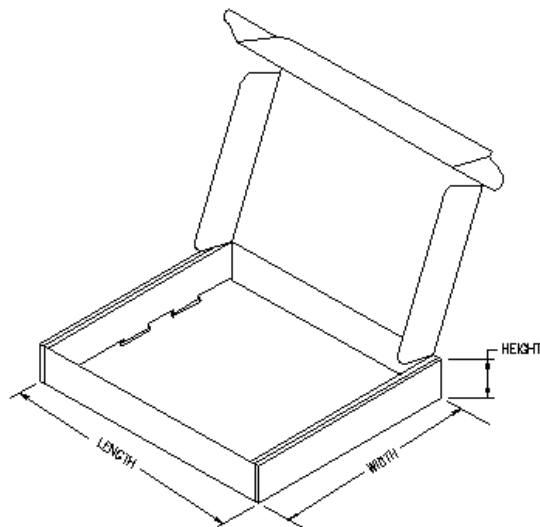

DBQ (R-PDSO-G16)

PLASTIC SMALL-OUTLINE PACKAGE

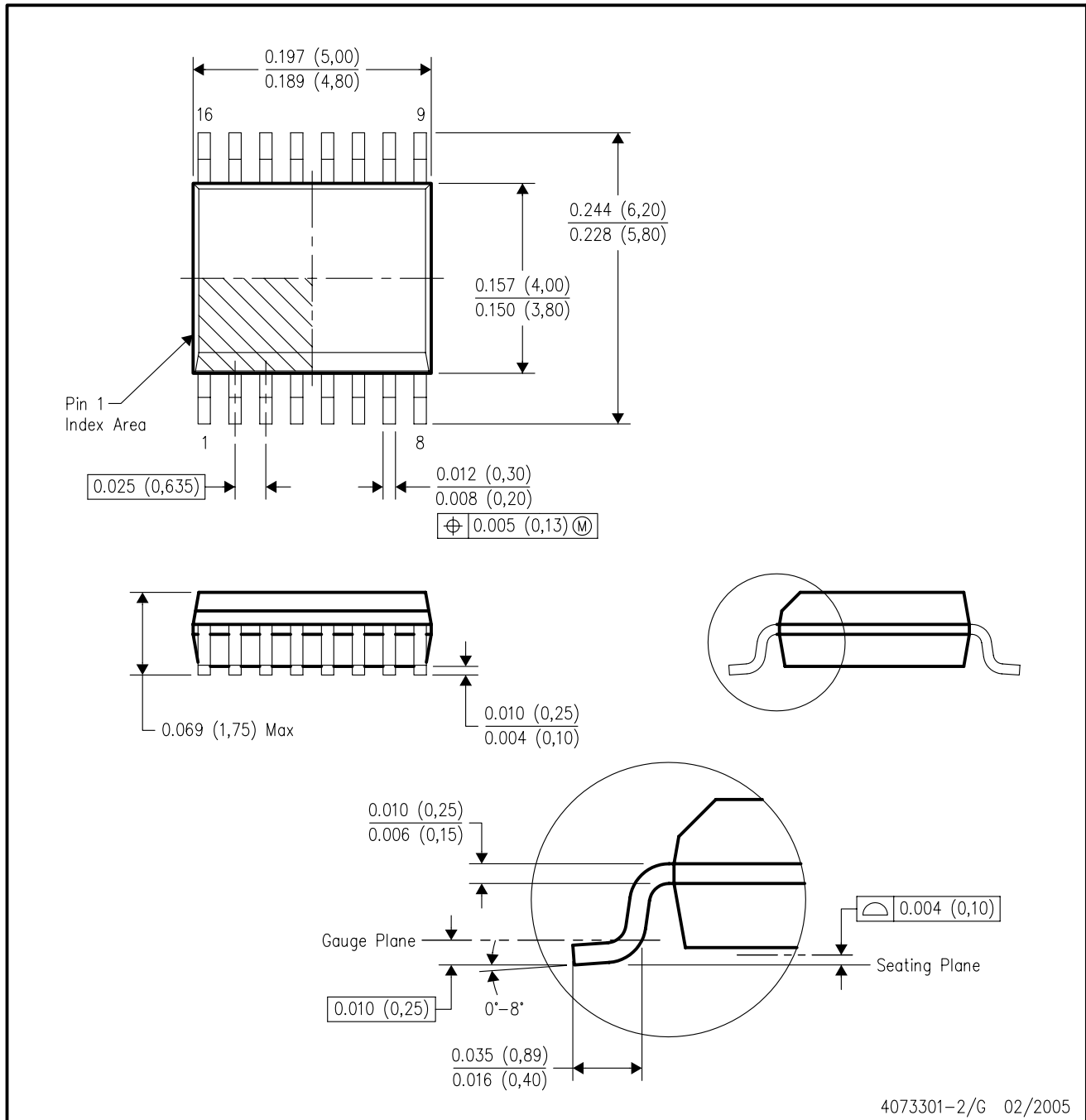

- NOTES:
- A. All linear dimensions are in inches (millimeters).
  - B. This drawing is subject to change without notice.
  - C. Body dimensions do not include mold flash or protrusion not to exceed 0.006 (0,15) per side.
  - D. Falls within JEDEC MO-137 variation AB.

## IMPORTANT NOTICE

Texas Instruments Incorporated and its subsidiaries (TI) reserve the right to make corrections, modifications, enhancements, improvements, and other changes to its products and services at any time and to discontinue any product or service without notice. Customers should obtain the latest relevant information before placing orders and should verify that such information is current and complete. All products are sold subject to TI's terms and conditions of sale supplied at the time of order acknowledgment.

TI warrants performance of its hardware products to the specifications applicable at the time of sale in accordance with TI's standard warranty. Testing and other quality control techniques are used to the extent TI deems necessary to support this warranty. Except where mandated by government requirements, testing of all parameters of each product is not necessarily performed.

TI assumes no liability for applications assistance or customer product design. Customers are responsible for their products and applications using TI components. To minimize the risks associated with customer products and applications, customers should provide adequate design and operating safeguards.

TI does not warrant or represent that any license, either express or implied, is granted under any TI patent right, copyright, mask work right, or other TI intellectual property right relating to any combination, machine, or process in which TI products or services are used. Information published by TI regarding third-party products or services does not constitute a license from TI to use such products or services or a warranty or endorsement thereof. Use of such information may require a license from a third party under the patents or other intellectual property of the third party, or a license from TI under the patents or other intellectual property of TI.

Reproduction of information in TI data books or data sheets is permissible only if reproduction is without alteration and is accompanied by all associated warranties, conditions, limitations, and notices. Reproduction of this information with alteration is an unfair and deceptive business practice. TI is not responsible or liable for such altered documentation.

Resale of TI products or services with statements different from or beyond the parameters stated by TI for that product or service voids all express and any implied warranties for the associated TI product or service and is an unfair and deceptive business practice. TI is not responsible or liable for any such statements.

TI products are not authorized for use in safety-critical applications (such as life support) where a failure of the TI product would reasonably be expected to cause severe personal injury or death, unless officers of the parties have executed an agreement specifically governing such use. Buyers represent that they have all necessary expertise in the safety and regulatory ramifications of their applications, and acknowledge and agree that they are solely responsible for all legal, regulatory and safety-related requirements concerning their products and any use of TI products in such safety-critical applications, notwithstanding any applications-related information or support that may be provided by TI. Further, Buyers must fully indemnify TI and its representatives against any damages arising out of the use of TI products in such safety-critical applications.

TI products are neither designed nor intended for use in military/aerospace applications or environments unless the TI products are specifically designated by TI as military-grade or "enhanced plastic." Only products designated by TI as military-grade meet military specifications. Buyers acknowledge and agree that any such use of TI products which TI has not designated as military-grade is solely at the Buyer's risk, and that they are solely responsible for compliance with all legal and regulatory requirements in connection with such use.

TI products are neither designed nor intended for use in automotive applications or environments unless the specific TI products are designated by TI as compliant with ISO/TS 16949 requirements. Buyers acknowledge and agree that, if they use any non-designated products in automotive applications, TI will not be responsible for any failure to meet such requirements.

Following are URLs where you can obtain information on other Texas Instruments products and application solutions:

<b>Products</b>		<b>Applications</b>	
Amplifiers	<a href="http://amplifier.ti.com">amplifier.ti.com</a>	Audio	<a href="http://www.ti.com/audio">www.ti.com/audio</a>
Data Converters	<a href="http://dataconverter.ti.com">dataconverter.ti.com</a>	Automotive	<a href="http://www.ti.com/automotive">www.ti.com/automotive</a>
DSP	<a href="http://dsp.ti.com">dsp.ti.com</a>	Broadband	<a href="http://www.ti.com/broadband">www.ti.com/broadband</a>
Interface	<a href="http://interface.ti.com">interface.ti.com</a>	Digital Control	<a href="http://www.ti.com/digitalcontrol">www.ti.com/digitalcontrol</a>
Logic	<a href="http://logic.ti.com">logic.ti.com</a>	Military	<a href="http://www.ti.com/military">www.ti.com/military</a>
Power Mgmt	<a href="http://power.ti.com">power.ti.com</a>	Optical Networking	<a href="http://www.ti.com/opticalnetwork">www.ti.com/opticalnetwork</a>
Microcontrollers	<a href="http://microcontroller.ti.com">microcontroller.ti.com</a>	Security	<a href="http://www.ti.com/security">www.ti.com/security</a>
RFID	<a href="http://www.ti-rfid.com">www.ti-rfid.com</a>	Telephony	<a href="http://www.ti.com/telephony">www.ti.com/telephony</a>
Low Power Wireless	<a href="http://www.ti.com/lpw">www.ti.com/lpw</a>	Video & Imaging	<a href="http://www.ti.com/video">www.ti.com/video</a>
		Wireless	<a href="http://www.ti.com/wireless">www.ti.com/wireless</a>

Mailing Address: Texas Instruments, Post Office Box 655303, Dallas, Texas 75265  
Copyright © 2007, Texas Instruments Incorporated