

Reflective Object Sensor Type OPB755N

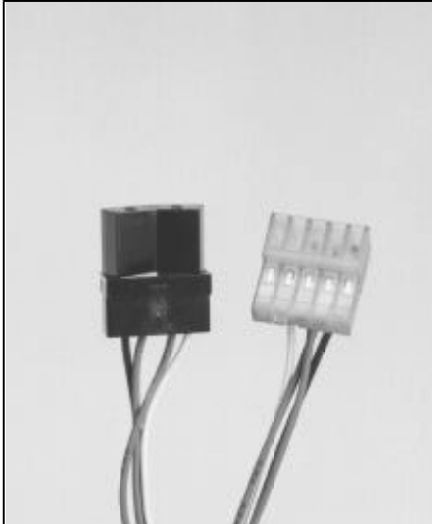

Features

- High contrast ratio 1000 to 1 minimum
- 12.0" ± 0.5" min. UL#1429 26 AWG wire leads terminated into an AMP #640442-5 connector
- Low cost plastic housing

Description

The OPB755N reflective assembly features a phototransistor output designed to decrease low-level light gain while not affecting the high-level light gain. Available with two mounting tabs as OPB755T.

Available with PC Board mountable leads as OPB750 series. Photologic® output sensors available in OPB760/OPB770 series.

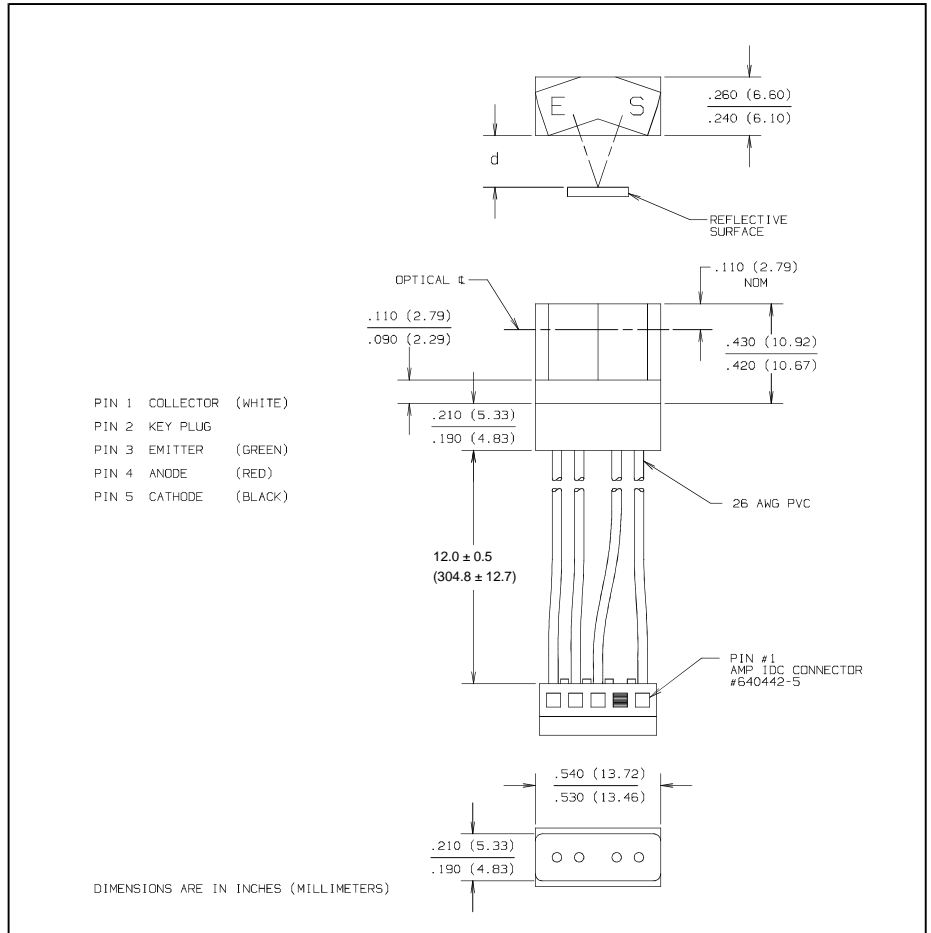

Absolute Maximum Ratings (T_A = 25° C unless otherwise noted)

Storage and Operating Temperature Range -40° C to +80° C

Input Diode

Forward DC Current 50 mA
 Peak Forward Current (1 μs pulse width, 300 pps) 3.0 A
 Reverse DC Voltage 2.0 V
 Power Dissipation 100 mW

Output Phototransistor

Collector-Emitter Voltage 30 V
 Collector DC Current 30 mA
 Power Dissipation 100 mW

Notes:

- (1) Derate Linearly 1.82 mW/° C above 25° C.
- (2) All parameters tested using pulse technique.
- (3) Methanol or isopropanol are recommended as cleaning agents. Plastic housing is soluble in chlorinated hydrocarbons and ketones.
- (4) Photocurrent is measured using an Eastman Kodak Neutral White test card having a 90% diffuse reflectance as a reflecting surface. Reference: Eastman Kodak, Catalog #1257795.
- (5) I_{C(OFF)} is the photocurrent measured with current to the input diode and a 5% reflecting surface.



For RoHS compliant devices add "Z" to the end of the part number: OPB755NZ

Type OPB755N

Electrical Characteristics ($T_A = 25^\circ\text{C}$ unless otherwise noted)

SYMBOL	PARAMETER	MIN	MAX	UNITS	TEST CONDITIONS
Input Diode					
V_F	Forward Voltage		1.80	V	$I_F = 40\text{ mA}$
I_R	Reverse Current		100	μA	$V_R = 2.0\text{ V}$
Output Phototransistor					
$V_{(BR)CEO}$	Collector-Emitter Breakdown Voltage	30		V	$I_C = 100\ \mu\text{A}$
I_{CEO}	Collector Dark Current		100	nA	$V_{CE} = 10\text{ V}, I_F = 0, H = 0$
Coupled					
$V_{CE(SAT)}$	Saturation Voltage		0.40	V	$I_C = 150\ \mu\text{A}, I_F = 30\text{ mA}, d = 0.22''$
$I_{C(ON)}$	On-State Collector Current	500		μA	$V_{CE} = 5\text{ V}, I_F = 30\text{ mA}, d = 0.08''^{(4)}$
		375		μA	$V_{CE} = 5\text{ V}, I_F = 30\text{ mA}, d = 0.15''^{(4)}$
		250		μA	$V_{CE} = 5\text{ V}, I_F = 30\text{ mA}, d = 0.22''^{(4)}$
$I_{C(OFF)}$	Off-State Collector Current		250	nA	$I_F = 30\text{ mA}, V_{CE} = 5\text{ V},^{(5)}$ $d = 0.08'', 0.15'', 0.22''$

REFLECTIVE OBJECT SENSOR

Typical Performance Curves

Normalized Collector Current vs. Object Distance

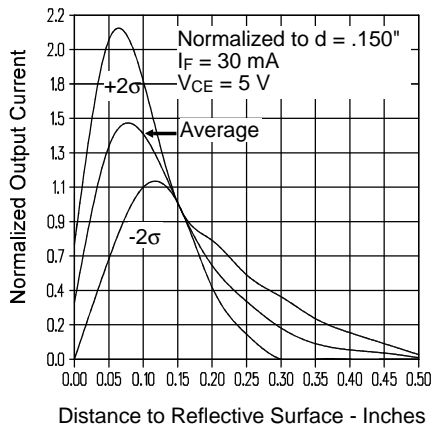

Normalized Output Current vs. Forward Current

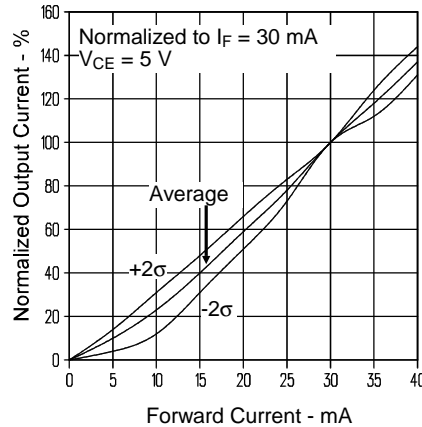

Optek reserves the right to make changes at any time in order to improve design and to supply the best product possible.

Optek Technology, Inc. 1215 W. Crosby Road Carrollton, Texas 75006 (972) 323-2200 Fax (972) 323-2396