

850nm Fast Ethernet Transceiver in 1 x 7 SMD Package



OPF5020

Technical Data

Features

- Small Form Factor surface mount package
- MT-RJ Receptacle
- Low cost 850 nm LED design
- Link distance up to 300m at 125Mbps
- Fully complies with the 100BASE-SX Fast Ethernet Standard (TIA-785)
- Single +5V power supply

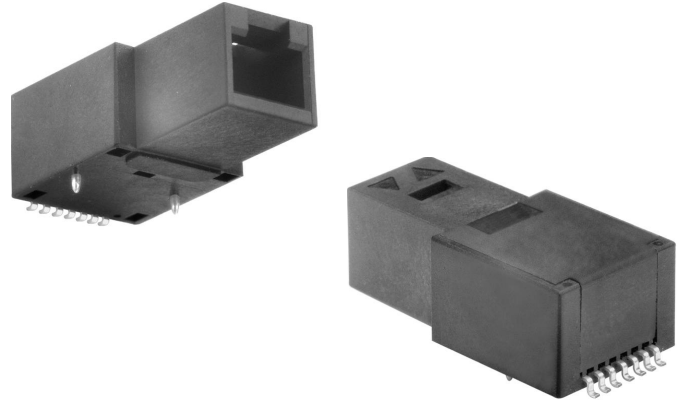

Description

Optek's OPF5020 is a 125Mbps SFF transceiver for use in data communications applications. It utilizes a MT-RJ dual fiber receptacle which features a small size and intuitive latching mechanism design which allows for higher density implementations and easier end-user installation.

The transmitter is an 850 nm GaAlAs LED, configured for optimum transceiver performance when used in conjunction with a low-side driver. The coupling efficiency of the LED and optical system allows the device to be used at low current levels, reducing power consumption and increasing system reliability.

The receiver consists of a high speed PIN photodiode coupled to a low noise transimpedance amplifier. The receiver output is a low impedance analog source. The analog representation of the received optical input can be easily converted to PECL or TTL levels by external circuitry to be used in digital modes up to 125Mbps, NRZ.

Combining the OPF5020 with commercially available LED driver and post amplifier circuits results in a physical layer medium dependent (PMD) sub-layer for communication between nodes of a fiber network. Optek **Application Bulletin 217** presents an example PMD design with typical receiver sensitivity of -30dBm at a BER of 2.5×10^{-10} , operating full duplex with either a $2^{23}-1$ or worst case FDDI data pattern.

The OPF5020 has been fully tested in accordance with Bellcore 468. See **Application Bulletin 219** for full details.

Absolute Maximum Ratings

Storage Temperature Range	-40 to +85 °C
Operating Temperature Range	0 to +70 °C
Soldering Temperature (Soldering Iron)	260 °C for 10 Seconds
Soldering Temperature (Vapor Phase Reflow)	235 °C for 30 Seconds

Transmitter

Forward Input Current (DC)	100 mA
Reverse Input Voltage	3.5 V

Receiver

Supply Voltage Range	-0.5 to 6V
Output Current	25mA

Notes:

1. All transmitters are subjected to 100% burn-in testing. Test conditions are 96 hours at 60 mA continuous current and 85°C ambient temperature.
2. This component is susceptible to damage from electrostatic discharge (ESD). Normal electronic component handling precautions should be observed during handling and assembly of this component to avoid damage or performance degradation.
3. Safety Information:
 - Class 1 Laser Product (850nm Light Emitting Diode)
 - TUV certified to EN60825-1:1994+A11+A2 and IEC 60950:1999/ EN60950:2000

OPF5020 Technical Data



Transmitter Electrical/Optical Characteristics

Operating Temperature Range 0 to 70°C unless otherwise noted; Rx Vcc = 4.75 to 5.25V

SYMBOL	PARAMETER	MIN	TYP	MAX	UNITS	TEST CONDITION
V _F	Forward Voltage	1.3	1.7	2.1	V	I _F = 60mA
V _R	Reverse Input Breakdown Voltage	3.5	9.0		V	I _R = 100μA
λ _P	Peak Emission Wavelength	820	840	865	nm	I _F = 60mA
λ _{BW}	Spectral Bandwidth (FWHM)			60	nm	I _F = 60mA
C _T	Capacitance		55		pF	V = 0 V, f = 1 MHz
P _T	Peak Output Optical Power ⁽¹⁾	-16.0		-9.0	dBm	I _F = 60mA
ΔP _T /ΔT	Optical Power Temperature Coefficient		-0.008		dBm/°C	I _F = 60mA
t _r /t _f	Rise/Fall Time ⁽²⁾		3.5	6.5	ns	I _F = 60mA, No Pre-bias

Receiver Electrical, Optical & Dynamic Characteristics

Operating Temperature Range 0 to 70°C unless otherwise noted; Rx Vcc = 4.75 to 5.25V

SYMBOL	PARAMETER	MIN	TYP	MAX	UNITS	TEST CONDITION
R _P	Responsivity ⁽³⁾⁽⁴⁾	5.3	7.4	-12.0	mV/μW	λ _P = 840nm, P _R = 63μW
V _{NO}	RMS Output Noise Voltage		530		μV	Noise BW = 100MHz; P _R = 0μW
P _N	Equivalent Optical Noise Input Power (RMS)		-41.0		dBm	Noise BW = 100MHz
P _{R(MAX)}	Maximum Input Optical Power ⁽³⁾⁽⁴⁾⁽⁵⁾	175			μW	
Z _O	Output Impedance		30		Ω	f = 50MHz
V _{ODC}	DC Output Voltage	1.00	2.1	2.80	V	P _R = 0μW, R _L = 500Ω to Rx Vee
I _{CC}	Power Supply Current		9	15	mA	R _L = Open
t _r /t _f	Rise/Fall Time ⁽³⁾⁽⁴⁾		3.5	6.5	ns	P _R = 63μW; C _L < 15pF
DCD	Duty Cycle Distortion		0.4	1.2	ns	P _R = 75μW
BW	Bandwidth	100	125		MHz	-3dB Electrical

Typical values are at TA = 25 C, Rx Vcc - Rx Vee = 5.00V

Notes:

1. Coupled optical power using a 2 to 5 meter length of 62.5/125 μm fiber cable, NA = 0.28
2. Rise and Fall times shown here are valid for a 50Ω driver impedance. Rise and fall times obtained using commercial LED driver circuits can be significantly lower. Refer to Application Bulletin 217 for more details.
3. P_R is defined as average coupled optical power at the receiver input.
4. Square wave light input: 12.5MHz, tr and tf < 2.0ns, extinction ratio < 10%; AC coupled; 500Ω load to Rx Vee.
5. Defined with DCD < 1.2ns.
6. Square wave light input: 50MHz, tr and tf < 2.0ns, extinction ratio < 10%; AC coupled; 500Ω load to Rx Vee.

OPF5020 Technical Data

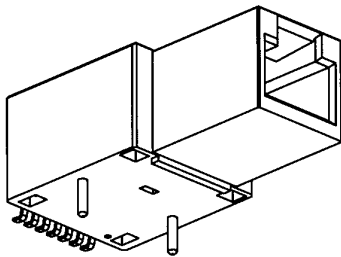
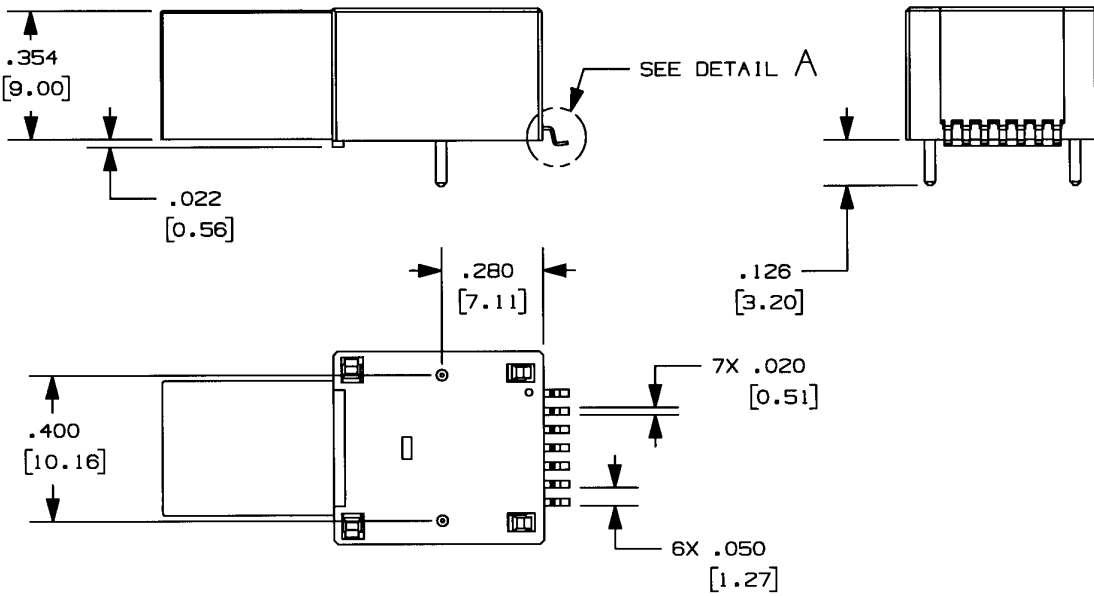
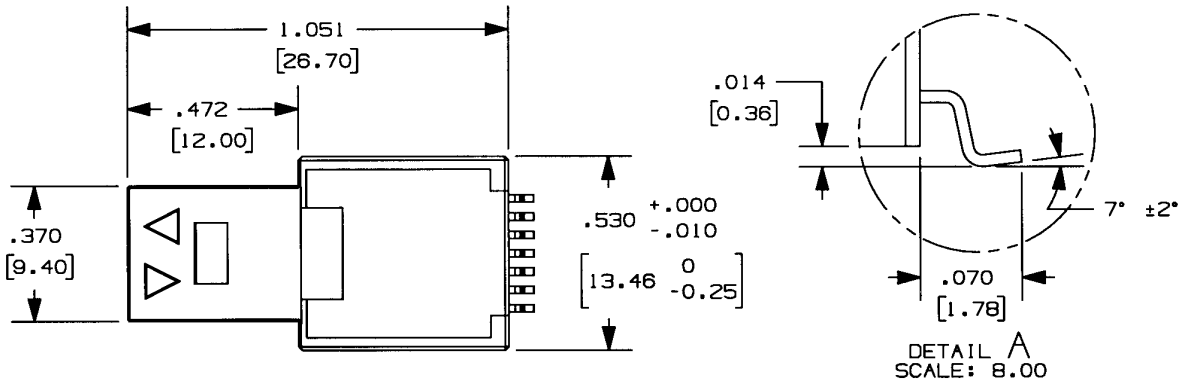

PIN	DEVICE	FUNCTION
7	Emitter	Tx Vcc
6	Emitter	Tx In
5	Emitter	Tx Vee
4	Detector	Guard
3	Detector	Rx Vcc
2	Detector	Rx Vee
1	Detector	Rx Out

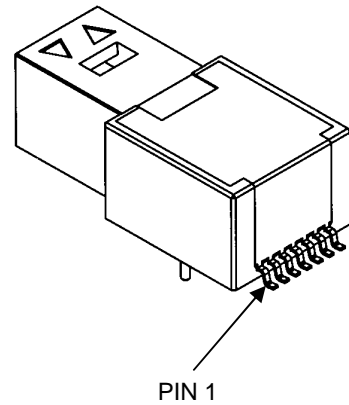

OPF5020 Technical Data



Packaging Information

REEL

Material: Antistatic, Type A, 56mm LOKREEL
Overall Diameter: 13 inches (325mm)
Hub Diameter: 4 inches (100mm)
Hub Width: 56.5mm
Surface: 10^{11} ohm/sq (maximum rating)

POCKET TAPE

Material: Antistatic, HMS-10-13-A
Width (W): 56mm
Pitch (P): 24mm pocket-to-pocket
Sprocket Pitch: 4mm
Pocket Depth (K_0): 10.92mm

COVER:

Material: Conductive, Pressure Sensitive
Width : 49.5mm

OTHER PROPERTIES:

Parts per Reel: 200
Leader: 17 Pockets

DIMENSIONS FOR PCB LAYOUT

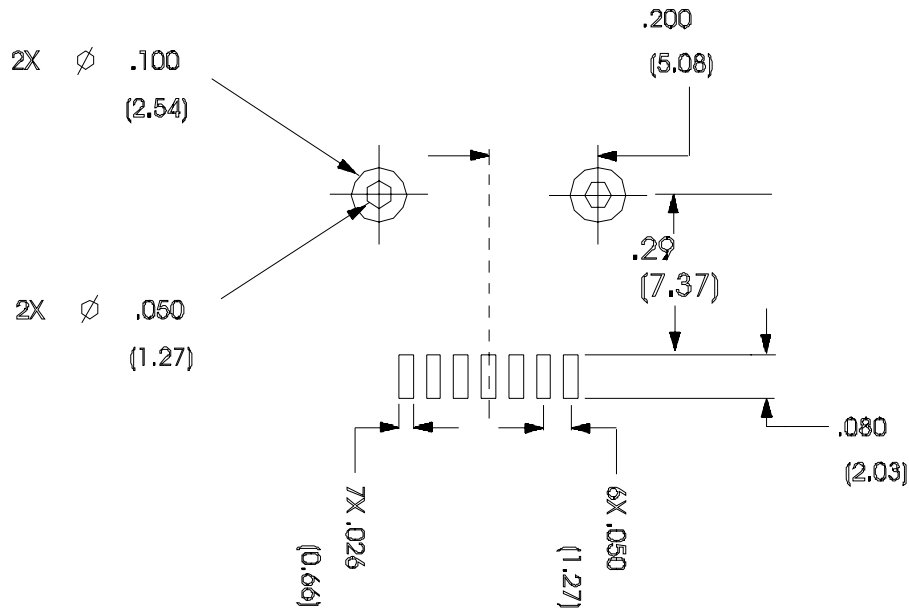

October 2002
OPF5020, Rev. B

Optek reserves the right to make changes at any time in order to improve design and to supply the best product possible.