

Vertical Cavity Surface Emitting Laser in TO-46 Dome Lens Package



OPV202

Features

- 850nm VCSEL Technology
- High thermal stability
- Low drive current/high output intensity
- TO-46 Package with Dome Lens
- Highly collimated beam profile

Description

The OPV202 is a high performance 850nm VCSEL packaged for sensing applications. This product's combination of features including high speed, high output power and concentric beam makes it an ideal transmitter for integration into all types of position sensing equipment.

Applications include:

- ◆ Photoelectric Sensors
- ◆ Light Curtains
- ◆ Position Sensors
- ◆ Encoders

Technical Data



Absolute Maximum Ratings ($T_A = 25^\circ\text{C}$ unless otherwise noted)

Maximum Forward Peak Current	30 mA
Maximum Reverse Voltage	5 Volts
Storage Temperature	-40 to +125°C
Operating Temperature	-40 to +85°C
Soldering Lead Temperature	260°C for 10 Seconds
Max. Continuous Optical Power at 70°C	1.1 mW



Additional laser safety information can be found on the Optek website. See application #221. Classification is not marked on the device due to space limitations. See package outline for centerline of optical radiance. Operating devices beyond maximum rating may result in hazardous radiation exposure.

OPV202 Technical Data



Electrical/Optical Characteristics (at 25 °C unless otherwise specified)

SYMBOL	PARAMETER	MIN	TYP	MAX	UNITS	TEST CONDITION
P_{OT}	Total Power Out	1.4		4.5	mW	$I_F = 12 \text{ mA}$
I_{TH}	Threshold Current	2.0		5.5	mA	Note 1
V_F	Forward Voltage			2.15	V	$I_F = 12 \text{ mA}$
I_R	Reverse Current			30	nA	$V_R = 5 \text{ V}$
R_S	Series Resistance	14		40	ohms	Note 2
η	Slope Efficiency	0.17			mW/mA	Note 3
λ	Wavelength	830		860	nm	
$\Delta\lambda$	Optical Bandwidth			0.85	nm	
$\Delta\eta/\Delta T$	Temp Coefficient of Slope Efficiency		-0.40		%/°C	
θ	Beam Divergence		2		Degree	
$\Delta\lambda/\Delta T$	Temp Coefficient of Wavelength		0.06		nm/°C	(0° - 70° C)
$\Delta I_{TH}/\Delta T$	Temp Coefficient of Threshold Current		± 1.5		mA	(0° - 70° C)
N_{ri}	Relative Intensity Noise		-123		dB/Hz	
$\Delta V_F/\Delta T$	Temperature Coefficient for V_F		-2.5		mV/°C	

NOTES:

- (1) Threshold Current is based on the two line intersection method specified in Telcordia GR-468-Core. Line 1 from 6 mA to 8 mA. Line 2 from 0 mA to 2 mA.
- (2) Series Resistance is the slope of the Voltage-Current line from 8 to 12 mA.
- (3) Slope efficiency, is the slope of the best fit LI line from 8 mA above threshold to 12 mA.

Normalized Power vs. Angular Displacement

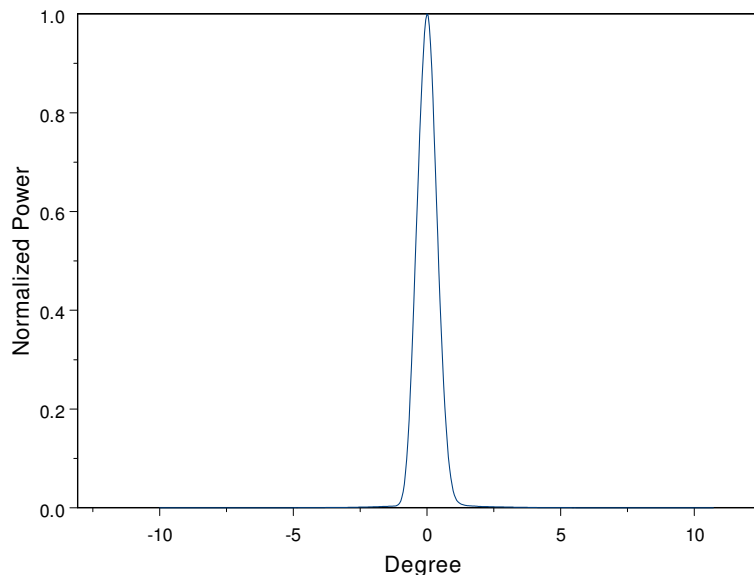

Output Power vs. Forward Current

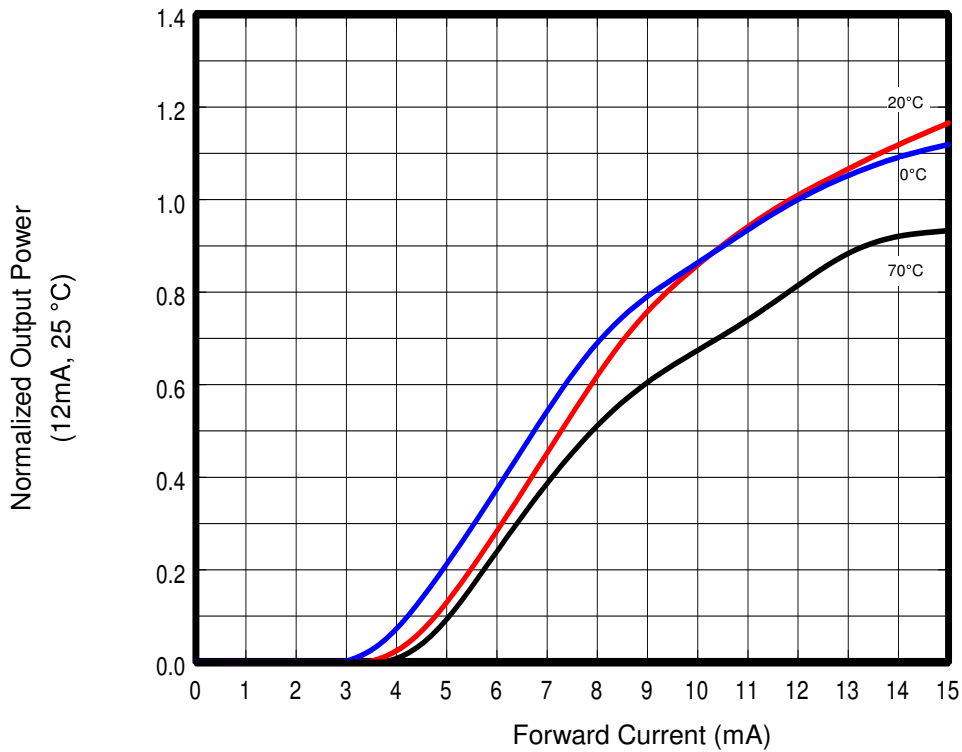

Forward Voltage vs. Forward Current

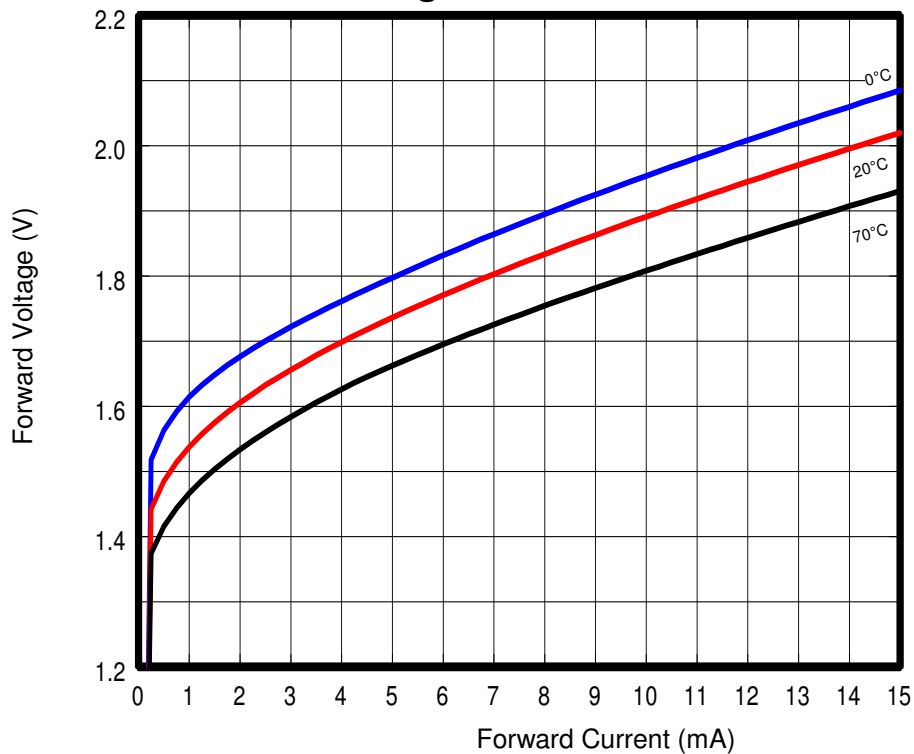

OPV202 Technical Data



Mechanical Dimensions:

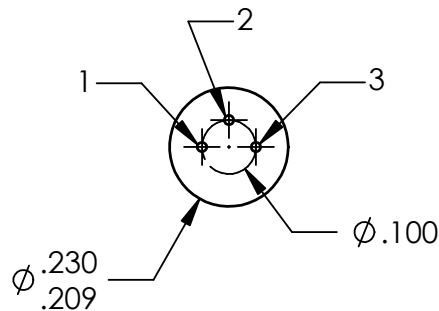
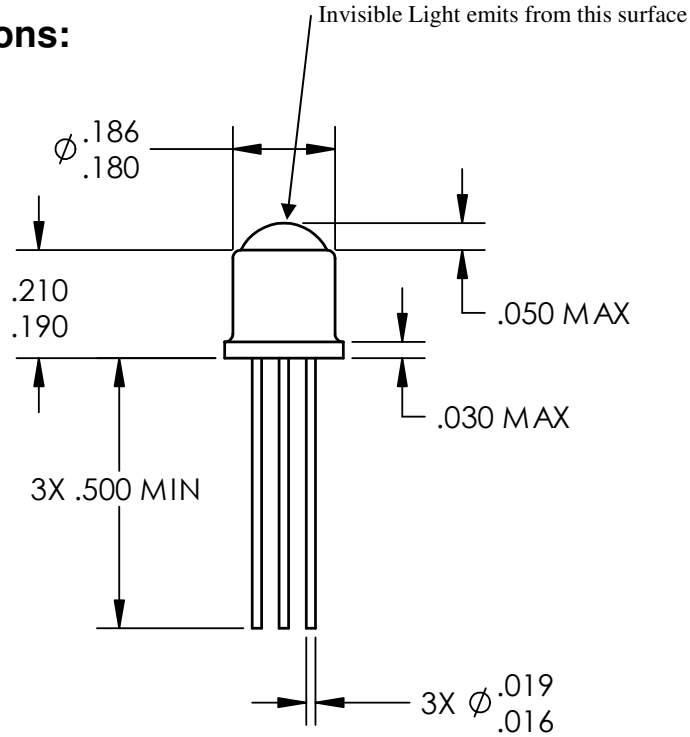

VCSEL

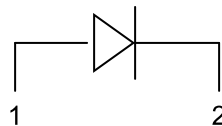

OPV202	
Pin	Connection
1	VCSEL Anode
2	VCSEL Cathode
3	No Connection

September 2003
Issue 3.1