

Vertical Cavity Surface Emitting Laser in TO-46 Package



OPV215, OPV215Y

Technical Data

Features

- Attenuated Optics
- 850 nm VCSEL technology
- High thermal stability
- Up to 1.25 Gbps
- Recommended for multimode fiber applications
- Microbead lens
- Pin out and attenuation options available on request
- Burned in for communication level reliability
- High optical coupling to MM fiber



Description

The OPV215 is a high performance 850nm VCSEL packaged for high speed communication links. OPV215 combines all the performance advantages of a VCSEL with the addition of a power monitor diode for precise control of optical power and about 30% optical attenuation for noise suppression.

The OPV215Y is identical electrically and optically and differs only in pin out. Refer to mechanical drawings for details.

This product's combination of features including high speed, high output power and concentric beam make it an ideal transmitter for integration into all types of data communications equipment.

Applications include:

- ◆ Fibre Channel
- ◆ Gigabit Ethernet
- ◆ ATM
- ◆ VSR (Very Short Reach)
- ◆ Intra-system links
- ◆ Optical backplane interconnects.

Absolute Maximum Ratings ($T_A = 25^\circ\text{C}$ unless otherwise noted)

Maximum Reverse Voltage	5 Volts
Storage Temperature	-40 to +125°C
Operating Temperature	-40 to +85°C
Soldering Lead Temperature	260°C for 10 Seconds
Max. Continuous Optical Power at 70°C	0.8 mW



Additional laser safety information can be found on the Optek website. See application #221. Classification is not marked on the device due to space limitations. See package outline for centerline of optical radiance. Operating devices beyond maximum rating may cause devices to exceed rated classification

September 2003
Issue 3.2

OPV215, OPV215Y Technical Data



Electrical/Optical Characteristics (at 25 °C unless otherwise specified)

SYMBOL	PARAMETER	MIN	TYP	MAX	UNITS	TEST CONDITION
P_{OT}	Power Out Total	0.7		3.0	mW	$I_F = 12 \text{ mA}$
I_{TH}	Threshold Current	2.0		5.5	mA	Note 1
V_F	Forward Voltage			2.15	V	$I_F = 12 \text{ mA}$
I_R	Reverse Current			30	nA	$V_R = 5 \text{ V}$
R_S	Series Resistance	14		40	ohms	Note 2
η	Slope Efficiency	0.10			mW/mA	Note 3
I_{RPD}	Reverse Current, photo diode			30	nA	$V_R = 5 \text{ V}$
	Linearity	0.0				Note 4
I_M	Monitor Current	20			μA	$I_F = 12 \text{ mA}, V_R = 5 \text{ V}$
λ	Wavelength	830		860	nm	
$\Delta\lambda$	Optical Bandwidth			0.85	nm	
t_r, t_f	Rise and Fall Time		200		ps	20% to 80%
N_{RI}	Relative Intensity Noise		-123		dB/Hz	
$\Delta\eta/\Delta T$	Temp Coefficient of Slope Efficiency		-40		%/°C	(0° - 70° C)
$\Delta\lambda/\Delta T$	Temp Coefficient of Wavelength		0.06		nm/°C	0° - 70° C
$\Delta I_{TH}/\Delta T$	Temp Coefficient of Threshold Current		± 1.5		mA	0° - 70° C
$\Delta V_F/\Delta T$	Temperature Coefficient for VF		-2.5		mV/°C	

NOTES:

- (1) Threshold Current is based on the two line intersection method specified in Telcordia GR-468-Core. Line 1 from 6 mA to 8 mA. Line 2 from 0 mA to 2 mA.
- (2) Series Resistance is the slope of the Voltage-Current line from 8 to 12 mA.
- (3) Slope efficiency, is the slope of the best fit LI line from 8 mA to 12 mA using no larger than .5 mA test interval points.
- (4) Using data points taken from slope efficiency, $\Delta L / \Delta I$ is calculated for each adjacent pair of 0.5mA points. The minimum is 0.0 (no negative values allowed)

September 2003
Issue 3.2

Optek reserves the right to make changes at any time in order to improve design and to supply the best product possible.

OPV215, OPV215Y Technical Data



Output Power vs. Forward Current

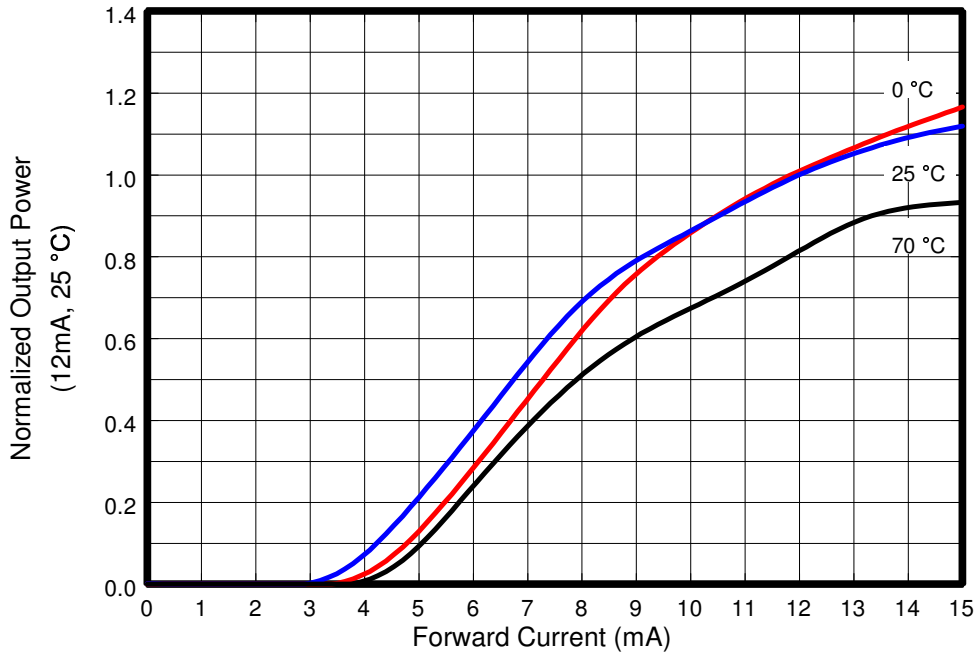

Forward Voltage vs. Forward Current

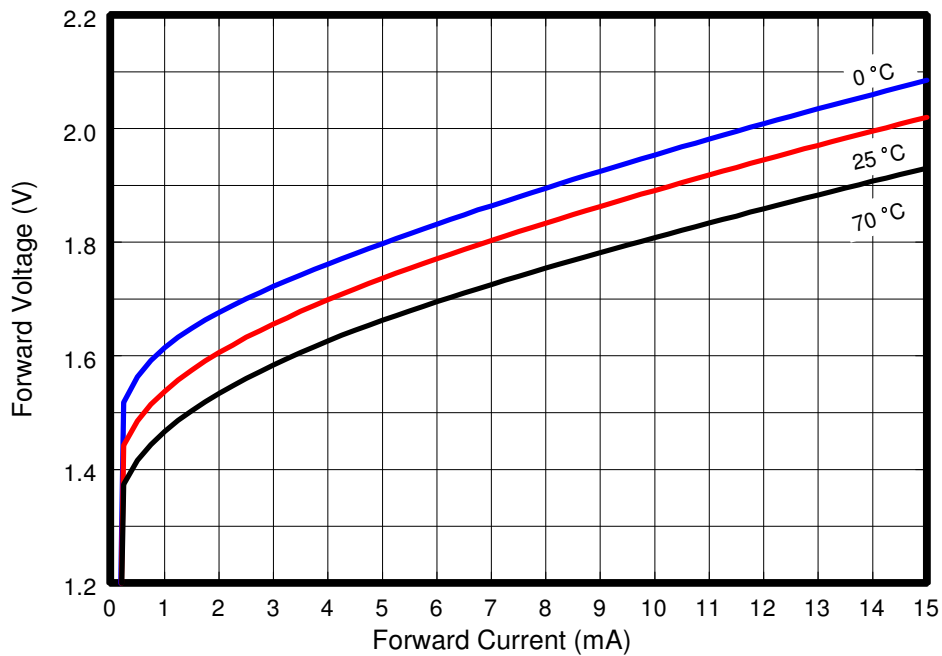

OPV215, OPV215Y Technical Data

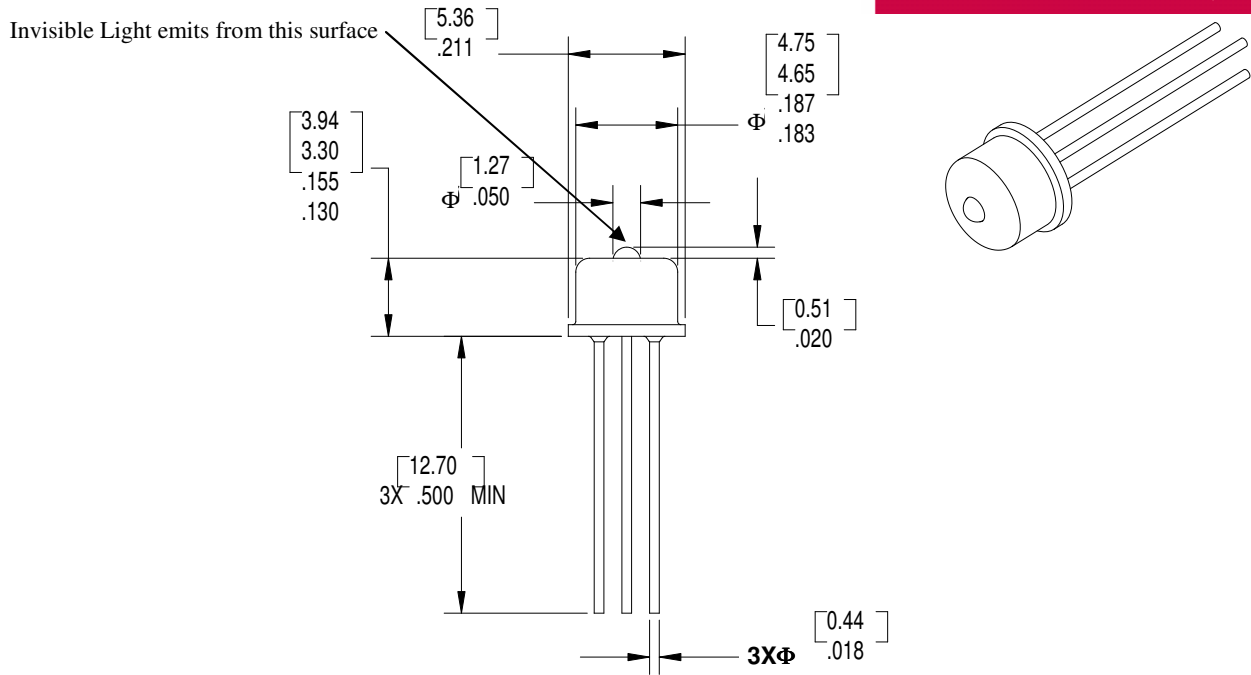

- 1) Tolerances are ± 0.005 unless otherwise specified
- 2) Dimensions in inches [mm]

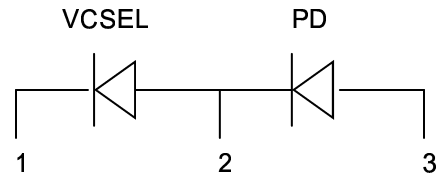
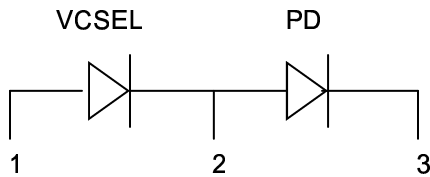
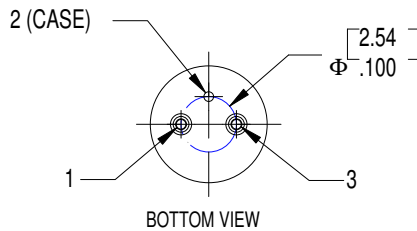

OPV215	
Pin	Connection
1	VCSEL Anode
2	VCSEL Cathode/PD Anode
3	PD Cathode

OPV215Y	
Pin	Connection
1	VCSEL Cathode
2	VCSEL Anode/PD Cathode
3	PD Anode

July 2002
OPV215, Rev. -

September 2003
Issue 3.2

Optek reserves the right to make changes at any time in order to improve design and to supply the best product possible.