

Vertical Cavity Surface Emitting Laser in ST Optical Sub-Assembly



OPV315YBT

Features:

- 850 nm VCSEL technology
- High thermal stability
- Up to 2.5 Gbps
- Recommended for multimode fiber applications
- Microbead lens
- Pin out and attenuation options available upon request
- Burned in for communication level reliability
- High optical coupling to MM fiber
- ST style receptacle



Description:

The OPV315YBT is a high performance 850nm VCSEL packaged for high speed communication links. OPV315YBT combines all the performance advantages of a VCSEL with the addition of a power monitor diode for precise control of optical power.

This product's combination of features including high speed, high output power and concentric beam makes it an ideal transmitter for integration into all types of data communications equipment.

Applications:

- Fiber channel
- Gigabit Ethernet
- ATM
- VSR (very short reach)
- Intra-system links applications
- Optical backplane interconnects

Absolute Maximum Ratings ($T_A = 25^\circ\text{C}$ unless otherwise noted)

Storage Temperature	-40° C to +125° C
Operating Temperature	0° C to +85° C
Soldering Lead Temperature	260° C for 10 Seconds
Maximum Forward Peak Current, Continuous	12 mA
Maximum Reverse Voltage	5 V
Maximum Forward, Current, pulsed 1 μs P.W., 10% D.C.)	48 mA



Additional laser safety information can be found on the Optek website. See application #221. Classification is not marked on the device due to space limitations. See package outline for centerline of optical radiance. Operating devices beyond maximum rating may cause devices to exceed rated classification.



RoHS

General Note

TT Electronics reserves the right to make changes in product specification without notice or liability. All information is subject to TT Electronics' own data and is considered accurate at time of going to print.

Vertical Cavity Surface Emitting Laser in ST Optical Sub-Assembly



OPV315YBT

Electrical Specifications

Electrical Characteristics ($T_A = 25^\circ\text{C}$ unless otherwise noted)

SYMBOL	PARAMETER	MIN	TYP	MAX	UNITS	TEST CONDITIONS
P_{T50}	Total coupled power 50/125 μm fiber	200			μW	$I_F = 7\text{ mA}$
I_{TH}	Threshold current	0.8		3.0	mA	Note 1
V_F	Forward voltage	1.6		2.2	V	$I_F = 7\text{ mA}$
I_R	Reverse current			100	nA	$V_R = 5\text{ V}$
R_S	Series resistance	20		55	Ohms	Note 2
η	Slope efficiency	20			$\mu\text{W}/\text{mA}$	Note 3
I_{RPD}	Reverse current, photodiode			35	nA	$V_R = 40\text{ V}$
I_M	Monitor current	30			μA	$I_F = 7\text{ mA}, V_R = 5\text{ V}$
λ	Wavelength	840		860	Nm	
$\Delta\lambda$	Optical bandwidth			0.85	Nm	
t_r	Rise time		90		Ps	20 to 80%
t_f	Fall time		120		Ps	80 to 20%
N_{RI}	Relatively intensity noise		-123		Db/Hz	
$\Delta\eta/\Delta T$	Temp coefficient of slope efficiency		-0.5		$\%/^\circ\text{C}$	$0^\circ - 70^\circ\text{C}$
ΔI_{TH}	Temp variance of threshold current		± 1.0		mA	$0^\circ - 70^\circ\text{C}$
$\Delta\lambda/\Delta T$	Temp coefficient of wavelength		0.06		$\text{Nm}/^\circ\text{C}$	$0^\circ - 70^\circ\text{C}$
$\Delta V_f/\Delta T$	Temperature coefficient for V_f		-2.5		$\text{Mv}/^\circ\text{C}$	

NOTES:

- Threshold Current is based on the two line intersection method specified in Telcordia GR-468-Core. Line 1 from 4 mA to 6mA. Line 2 from 0 mA to 0.5 mA.
- Series Resistance is the slope of the Voltage-Current line from 5 to 8 mA.
- Slope efficiency, is the slope of the best fit LI line from 5 mA to 8 mA using no larger than .25 mA test interval points. Measured with a 50/125 μm fiber.

NOTICE

This component is sensitive to electrostatic discharge (ESD). To prevent ESD-induced damage and/or degradation to equipment, take normal ESD precautions when handling this product.

General Note

TT Electronics reserves the right to make changes in product specification without notice or liability. All information is subject to TT Electronics' own data and is considered accurate at time of going to print.

TT Electronics | OPTEK Technology
1645 Wallace Drive, Carrollton, TX 75006 | Ph: +1 972 323 2200
www.ttelectronics.com | sensors@ttelectronics.com

Vertical Cavity Surface Emitting Laser in ST Optical Sub-Assembly



OPV315YBT

Performance

Normalized Output Power vs. Forward Current

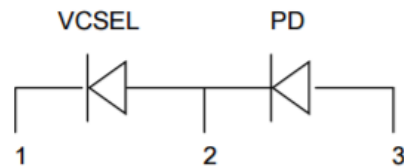
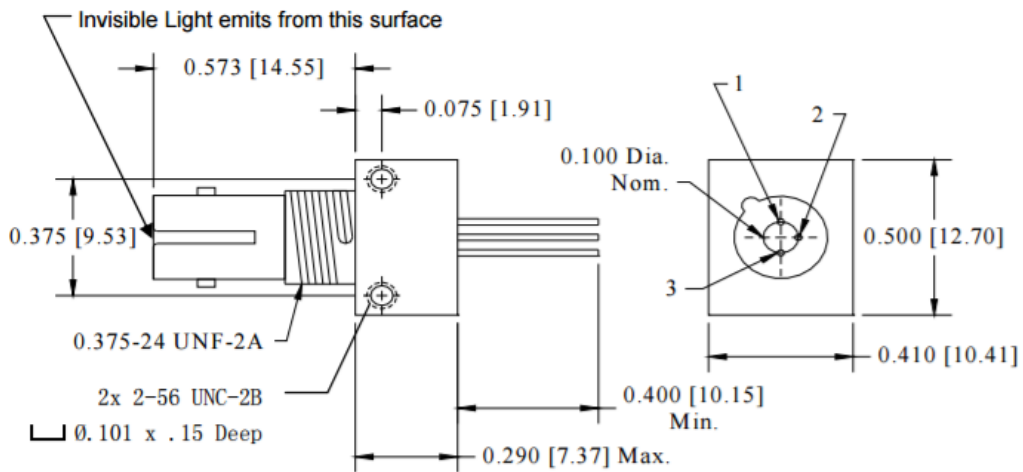
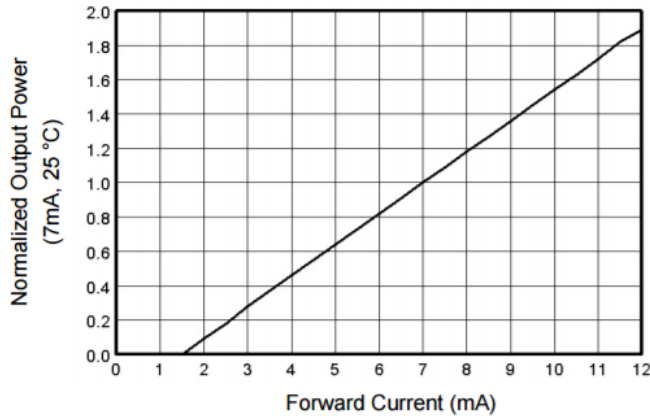

OPV315YBT	
Pin	Connection
1	VCSEL Cathode
2	VCSEL Anode/PD Cathode
3	PD Anode

General Note

TT Electronics reserves the right to make changes in product specification without notice or liability. All information is subject to TT Electronics' own data and is considered accurate at time of going to print.

TT Electronics | OPTEK Technology
 1645 Wallace Drive, Carrollton, TX 75006 | Ph: +1 972 323 2200
www.ttelectronics.com | sensors@ttelectronics.com