

■Features

- High Luminous Super Flux Output
- 5 ° Standard Directivity
- Long Lifetime Operation
- Low Thermal Resistance
- Superior Weather-Resistance
- UV Resistant Epoxy
- Water Clear Type

■Applications

- Automotive tail, stop, turn signal lamps and interior lighting
- Signage and channel letter
- Decoration and entertainment lighting
- Architectural lighting
- Other Lighting

■Absolute Maximum Rating

(Ta=25°C)

Item	Symbol	Value	Unit
DC Forward Current	I _F	50	mA
Pulse Forward Current*	I _{FP}	120	mA
Reverse Voltage	V _R	5	V
Power Dissipation	P _D	130	mW
Operating Temperature	T _{opr}	-30 ~ +85	°C
Storage Temperature	T _{stg}	-40 ~ +100	°C
Lead Soldering Temperature	T _{sol}	260°C/5sec	-

*Pulse width Max.10ms Duty ratio max 1/10

■Electrical -Optical Characteristics

(Ta=25°C)

Item	Symbol	Condition	Min.	Typ.	Max.	Unit
DC Forward Voltage	V _F	I _F =50mA	1.8	2.1	2.6	V
DC Reverse Current	I _R	V _R =5V	-	-	10	μA
Domi. Wavelength*	λ _D	I _F =50mA	620	625	630	nm
Luminous Intensity*	I _v	I _F =50mA	3000	4000	-	mcd
50% Power Angle	2θ _{1/2}	I _F =50mA	-	120	-	deg

*1 Tolerance of dominant wavelength is ±1nm

*2 Tolerance of luminous intensity is ±15%

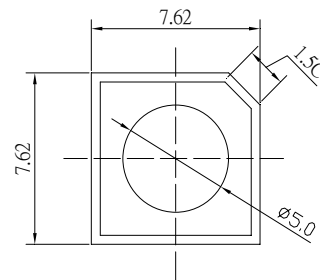
■Outline Dimension

Unit:mm

Tolerance:±0.3mm

1,4 Cathode

2,3 Anode

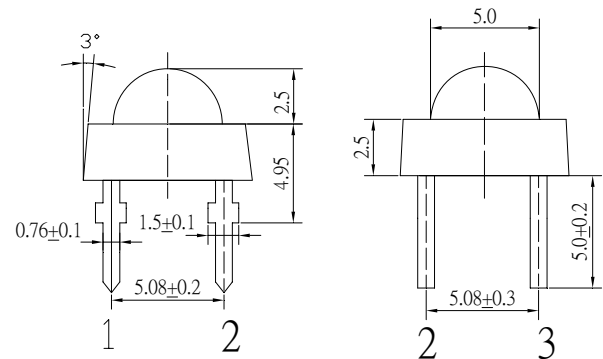
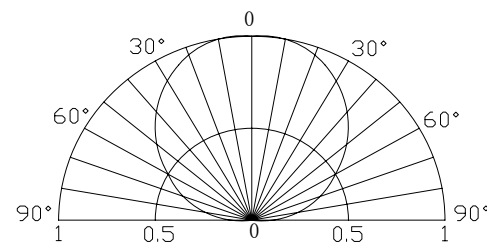
■Directivity

■Maximum Forward Current
