



OTA5180A

720x544 System-On-Chip Driver for 480RGBx272 TFT LCD

Preliminary

Sep. 26, 2008

Version 0.9

TABLE OF CONTENTS

	<u>PAGE</u>
1. GENERAL DESCRIPTION	4
2. FEATURES	4
3. ORDERING INFORMATION	4
4. BLOCK DIAGRAM	5
5. PIN ASSIGNMENT	6
6. SIGNAL DESCRIPTIONS	7
7. POWER APPLICATION CIRCUIT	10
8. 3-WIRE COMMAND FORMAT	11
8.1 3-WIRE COMMAND FORMAT	11
8.2 REGISTER SUMMARY	12
8.3 REGISTER DESCRIPTION	14
8.3.1 R0: Direction setting	14
8.3.2 R1: GRB、SHDB2、SHDB1、DISP	14
8.3.3 R2: CONTRAST	15
8.3.4 R3: SUB-CONTRAST_R	15
8.3.5 R4: SUB-CONTRAST_B	15
8.3.6 R5: BRIGHTNESS	15
8.3.7 R6: SUB- BRIGHTNESS _R	16
8.3.8 R7: SUB- BRIGHTNESS _B	16
8.3.9 R8: H_BLANKING	16
8.3.10 R9: VDPOL、HDPOL、V_BLANKING	16
8.3.11 R10: SYNC、DCLKPOL、CP3_FREQ、CP2_FREQ、CP1_FREQ	17
8.3.12 R11: LED_VFB、BL_DRV、DRV_FREQ、PFM_DUTY	18
8.3.13 R12: LED_ON_CYCLE、LED_ON_RATIO	19
8.3.14 R13: OP	20
8.3.15 R14: LC_TYPE	20
8.3.16 R15: VGH_SEL、VGL_SEL	20
8.3.17 R16: INVERSION	21
8.3.18 R17: VCOMH	21
8.3.19 R18: VCOML	21
8.3.20 R23: GM_V2	22
8.3.21 R24: GM_V3	22
8.3.22 R25: GM_V4	22
8.3.23 R26: GM_V5	22
8.3.24 R27: GM_V6	22
8.3.25 R28: GM_V7	22
8.3.26 R29: GM_V8	22
8.3.27 R30: GM_V9	22
9. ELECTRICAL SPECIFICATIONS	23
9.1 ABSOLUTE MAXIMUM RATINGS	23
9.2 DC CHARACTERISTICS	23

9.2.1	Recommended Operating Range	23
9.2.2	DC Characteristics for Digital Circuit.....	23
9.2.3	DC Characteristics for Analog Circuit.....	24
9.3	AC CHARACTERISTICS.....	24
9.4	AC TIMING DIAGRAM	25
9.4.1	Clock and Data Input Timing Diagram	25
9.4.2	3-Wire Communication Timing Diagram	25
10.	INPUT DATA FORMAT	26
10.1	PARALLEL RGB DATA FORMAT.....	26
10.1.1	Parallel RGB Input Timing Table	26
10.1.2	SYNC Mode Timing Diagram	26
10.1.3	SYNC-DE Mode Timing Diagram	27
10.2	SERIAL 8-BIT RGB DATA FORMAT	28
10.2.1	Serial 8-bit RGB Input Timing Table	28
10.2.2	SYNC Mode Timing Diagram	28
10.2.3	SYNC-DE Mode Timing Diagram	28
11.	POWER ON/OFF SEQUENCE.....	29
11.1.1	Power On Sequence.....	29
11.1.2	Power On Sequence.....	29
12.	OTP PROGRAM PROCEDURE	30
13.	RECOMMENDED PANEL ROUTING RESISTANCE.....	31
14.	APPLICATION CIRCUIT FOR DC-DC CONVERTER	32
15.	CHIP INFORMATION	33
15.1	PAD ASSIGNMENT	33
15.2	PAD DIMENSION.....	33
15.3	BUMP CHARACTERISTIC.....	33
15.4	PAD LOCATIONS.....	34
15.5	ALIGN KEY LOCATIONS	43
16.	COG PRODUCTS MANUFACTURING GUIDELINES	44
16.1	PURPOSE:	44
16.2	SCOPE:.....	44
16.3	NOUN DEFINITION	44
16.4	RESPONSIBILITY UNITY:.....	44
16.5	CONTENTS:	44
16.5.1	Applicable documents.....	44
16.5.2	ACF Characteristics:.....	44
16.5.3	ACF process :	44
16.6	REFERENCES:	44
17.	DISCLAIMER.....	45
18.	REVISION HISTORY	46

720x544 TFT-LCD DRIVER AND CONTROLLER

1. GENERAL DESCRIPTION

OTA5180A is a single chip driver solution combining a source driver, a gate driver, a timing controller, a power supply circuit and a back-light control circuit, especially designed for color TFT LCDs. The OTA5180A supports panel resolutions of 480xRGBx272. The system can be configured through a R/W 3-wire serial interface.

2. FEATURES

- n LCD driver with timing controller
- n Line/Frame Inversion
- n 720 source output channels
- n 544 gate output channels
- n 8-bit resolution 256 gray scale with dithering (6 bits DAC +2 bit dithering)
- n Support both SYNC and SYNC-DE mode input timing
- n Support parallel RGB (24-bit) input interface and Serial RGB (8-bit) input interface
- n Display control and configuration selected by 3-wire serial communication control
- n Built-in DC-DC control circuit, charge pump circuit, VCOM circuit with programmable adjustment
- n Built-in R-DAC gamma correction
- n Output deviation: 20mV
- n Power for LCD driving: 4.2V ~ 6V
- n Power for charge pump supply (VDD): 2.25V ~ 3.6V
- n Power for digital interface: 1.8V ~ VDD
- n Dual power mode application is acceptable when application board can provide 4.8V~6V supply along with VDD
- n COG package
- n Built-in power saving mode

3. ORDERING INFORMATION

Product Number	Package Type
OTA5180A-C	Chip form with Gold Bump

4. BLOCK DIAGRAM

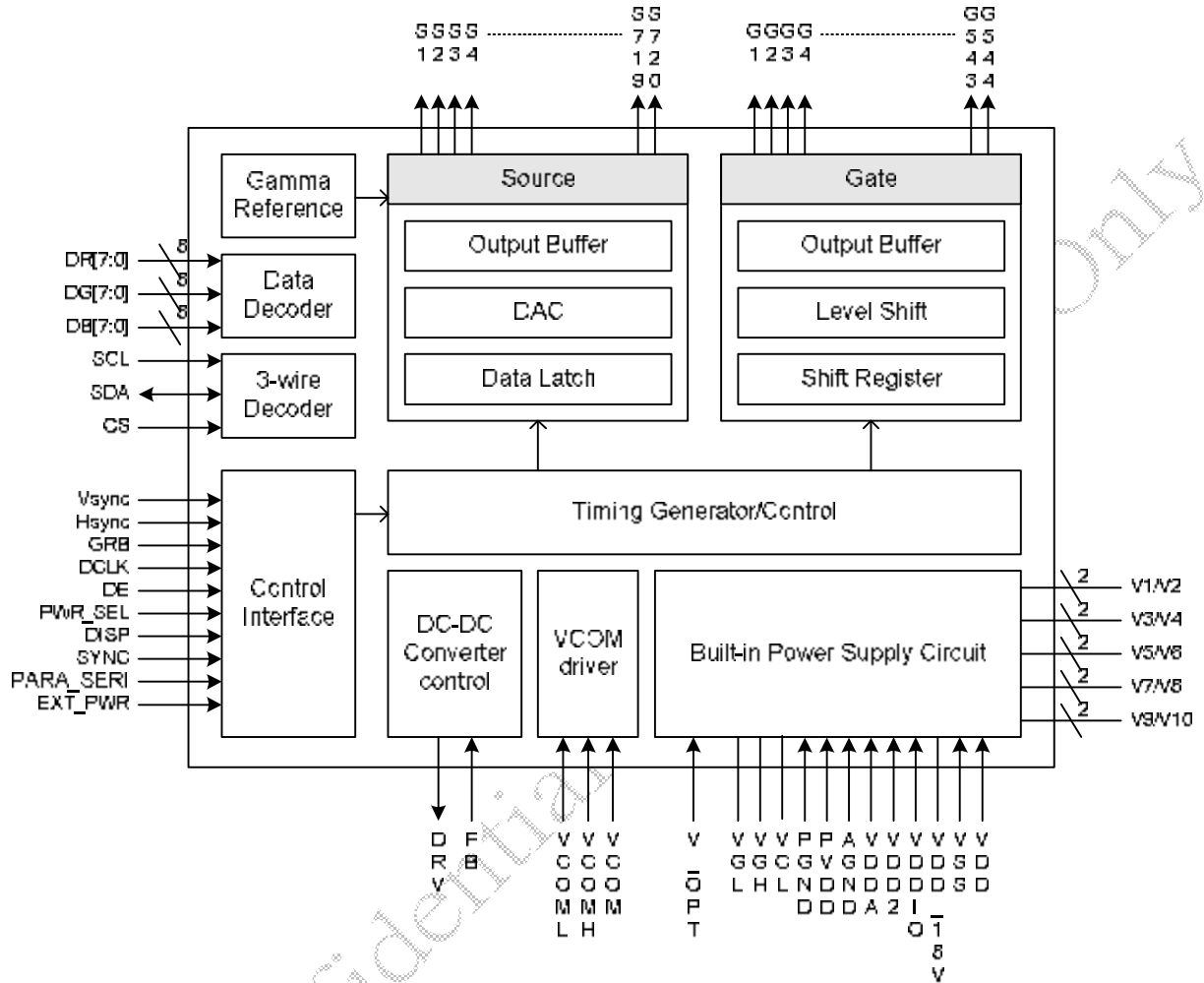

5. PIN ASSIGNMENT

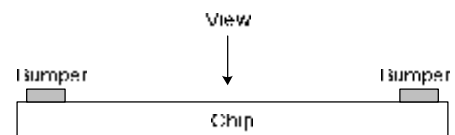
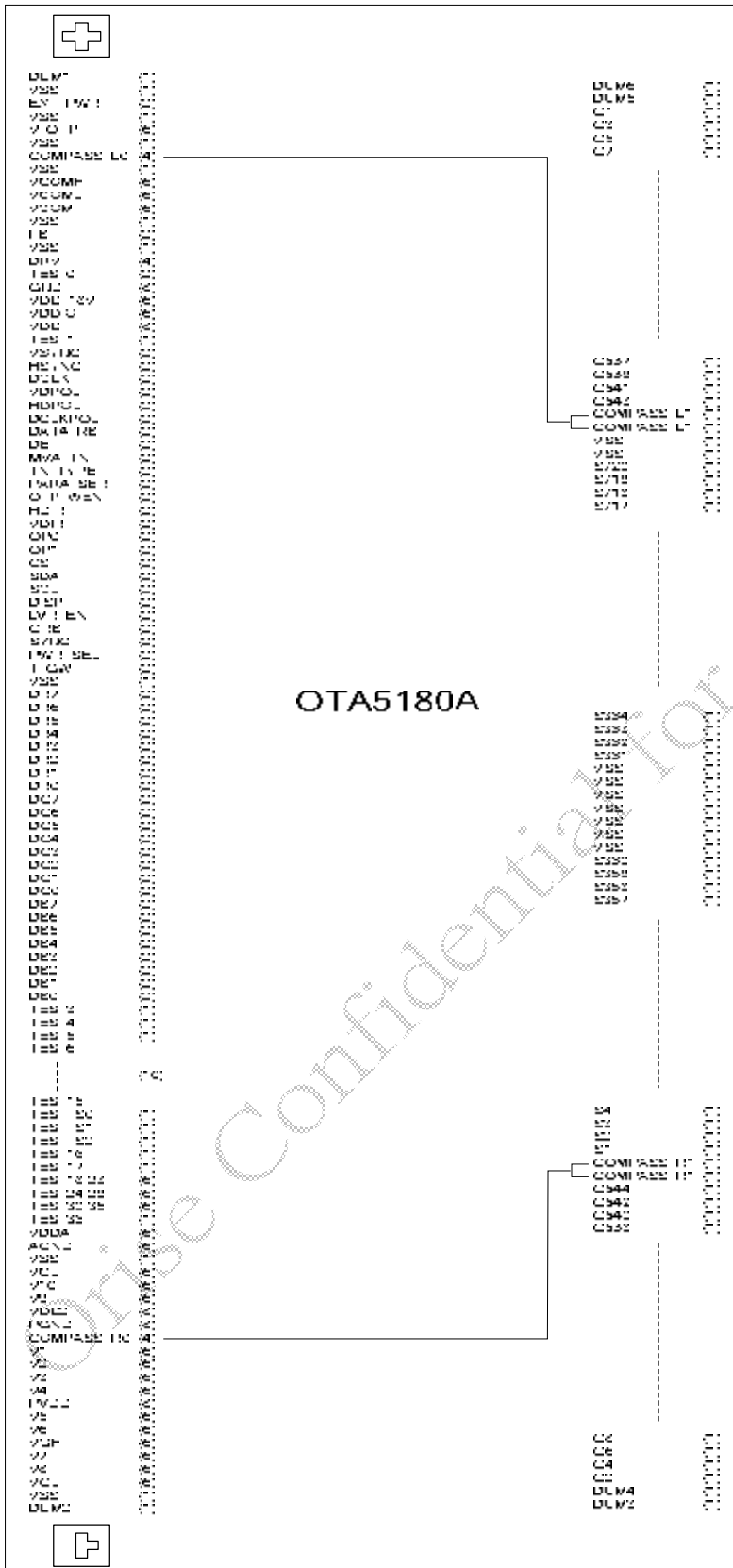

6. SIGNAL DESCRIPTIONS

SYMBOL	TYPE	DESCRIPTION
Serial Communication Interface / Timing Controller (Tcon) / Mode Selection		
CS	I (VDDIO)	Serial communication chip select
SDA	I/O (VDDIO)	Serial communication data input and output
SCL	I (VDDIO)	Serial communication clock input
PARA_SERI	I (VDDIO)	Parallel 24-bit and Serial 8-bit data input selection. PARA_SERI="H", Parallel 24-bit RGB input through DR0~7, DB0~DB7, DG0~DG7 (Default) PARA_SERI="L", Serial 8-bit data input through DG0~DG7
DR0~DR7	I (VDDIO)	When PARA_SERI="H", these will be treated as 8-bit digital Red data input When PARA_SERI="L", these will be treated as serial 8-bit data input
DG0~DG7	I (VDDIO)	8-bit digital Green data input, only valid when PARA_SERI="H"
DB0~DB7	I (VDDIO)	8-bit digital Blue data input, only valid when PARA_SERI="H"
DCLK	I (VDDIO)	Clock signal; latching data at the falling edge
HSYNC	I (VDDIO)	Horizontal sync signal; negative polarity
VSYNC	I (VDDIO)	Vertical sync signal; negative polarity
DE	I (VDDIO)	Data input enable. Active High to enable the data input.
SYNC	I (VDDIO)	SYNC or SYNC-DE mode selection: SYNC = "Low": accepted SYNC-DE mode input timing (Default) SYNC = "High": accepted SYNC mode input timing
HDIR	I (VDDIO)	Horizontal scan direction control (Please refer to the register setting : HDIR) HDIR(pin) = "Low" : The definition of HDIR register setting is inversion from original. HDIR(register) = "0" : Shift from left to right; HDIR(register) = "1" : Shift from right to left. (Default of the Register) HDIR(pin) = "High":The definition of HDIR register setting is invariant. (Default) HDIR(register) = "0" : Shift from right to left; HDIR(register) = "1" : Shift from left to right. (Default of the Register)
VDIR	I (VDDIO)	Vertical scan direction control (Please refer to the register setting : VDIR) VDIR(pin) = "Low": The definition of VDIR register setting is inversion from original. VDIR(register) = "0": Shift from up to down; VDIR(register) = "1": Shift from down to up. (Default of the Register) VDIR(pin) = "High": The definition of VDIR register setting is invariant. (Default) VDIR(register) = "0": Shift from down to up; VDIR(register) = "1": Shift from up to down. (Default of the Register)
MVA_TN	I (VDDIO)	Set the TN or MVA mode. MVA_TN= "Low" : TN MVA_TN= "High" : MVA mode. (Default)
TN_TYPE	I (VDDIO)	To identify the type of TN mode TN_TYPE = "Low" : The liquid crystal is TN mode1 TN_TYPE = "High" : The liquid crystal is TN mode2 (Default)
PWR_SEL	I (VDDIO)	Charge pump power selection When VDD=2.5V, PWR_SEL = "Low" When VDD=3.3V, PWR_SEL = "High" (Default)

OP0 - OP1	I (VDDIO)	Source driver driving capability selection. OP0 and OP1 pins are internal pulled to default setting.		
		OP1	OP0	Driving capability
		LOW	LOW	-25%
		LOW (Default)	HIGH (Default)	Normal (Default)
		HIGH	LOW	+25%
		HIGH	HIGH	+50%
VDPOL	I (VDDIO)	Vsync polarity control. VDPOL="1", negative polarity (default) VDPOL=0, positive polarity		
HDPOL	I (VDDIO)	Hsync polarity control. HDPOL="1", negative polarity (default) HDPOL="0", positive polarity		
DCLKPOL	I (VDDIO)	DCLK polarity control. DCLKPOL="1", negative polarity (default) DCLKPOL="0", positive polarity		
DATA_RB	I (VDDIO)	Data R[7:0] & B[7:0] exchanged internally DATA_RB="1" R[7:0]→B[7:0](internally) B[7:0]→R[7:0](internally) DATA_RB="0" R[7:0]→R[7:0](internally) B[7:0]→B[7:0](internally) (default)		
GRB	I (VDDIO)	Global reset. Active low, Internal pull high		
LVR_EN	I (VDDIO)	Low voltage reset enable. Active high. Internal pull high.		
DISP	I (VDDIO)	Display control / standby mode selection. DISP = "Low" : Standby; (Default) DISP = "High" : Normal display		
OTP_WEN	I (VDDIO)	OTP trim function enable control. OTP_WEN = "Low" : OTP trim function is disabled (Default) OTP_WEN = "High" : OTP trim function is enabled		
T_GW		Internal power setting control T_GW = "Low" : (Default) T_GW = "High" : Power system fits requirement of CPT TN panel.		
Source / Gate Driver				
S1~S720	O	Source driver output signals		
G1~G544	O	Gate driver output signals		
DC/DC Converter				
DRV	O	Power transistor gate signal for the boost converter		
FB	I	Main boost regulator feedback input. Connect feedback resistive divider to GND. FB threshold can be selected by register setting, usually 0.6V (default).		
VCOM Generator				
VCOM	O	Frame polarity output for VCOM. Swing between VCOMH and VCOML.		
VCOMH	C	Power supply for VCOM high level output.		
VCOML	C	Power supply for VCOM low level output.		
Power Supply				
VDD	P	Power supply for digital circuit		

GND	P	Ground pin for digital circuit
PVDD	P	Power supply for charge pump circuit
PGND	P	Ground pin for charge pump circuit
AGND	P	Ground for analog circuit
VDDIO	P	Power supply for digital interface I/O pins
V_OTP	P	Power input pin for customer OTP.
V[1:10]	C	Capacitor connect pin for internal charge pump. Refer to the illustration of power application circuit.
VDD_18	C	Power setting capacitor connect pin
VDD2	C	Power setting capacitor connect pins
VDDA	C	Power setting capacitor connect pins
VCL	C	Power setting capacitor connect pins
VGH	C	Power setting capacitor connect pins. Positive power supply for gate driver output.
VGL	C	Power setting capacitor connect pins. Negative power supply for gate driver output.
EXT_PWR	I (VDDIO)	VDD2 source selection. VDD2 can be applied externally only when application board can provide 4.8V~6V supply along with VDD. EXT_PWR = "Low" : VDD2 is supplied by external 5V supply. EXT_PWR = "High" : VDD2 is generated by internal pump circuit. (Default)
Others		
TEST[0:34]	T	Test pins for OriseTech internal testing only. User should leave it open.
TEST_S[0:2]	T	Test pins for OriseTech internal testing only. Internal pull low. User should leave it open or connect it to "low".
COMPASS_L[0:1]	S	Internal left pass line for COM signal between input and output pins
COMPASS_R[0:1]	S	Internal right pass line for COM signal between input and output pins

Classification of TYPE:

I: input, O: output, I/O: input/output, P: power input, PO: power out, D: dummy, S: short pin, T: test pin, M: mark, C: capacitor pin

7. POWER APPLICATION CIRCUIT

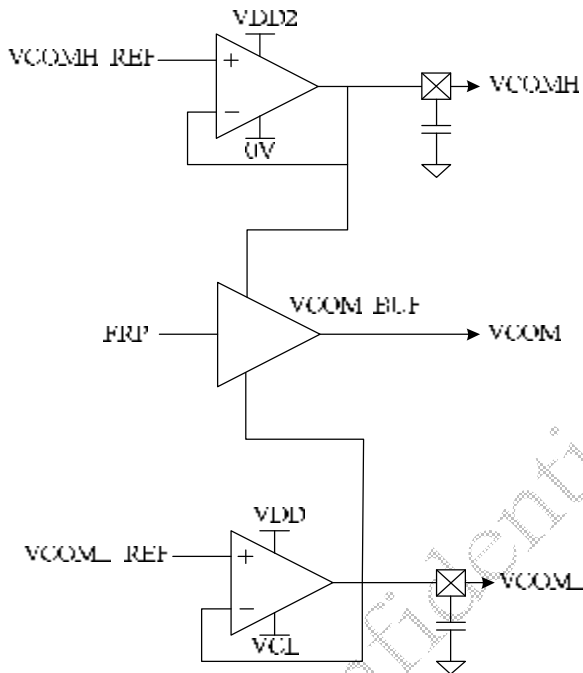
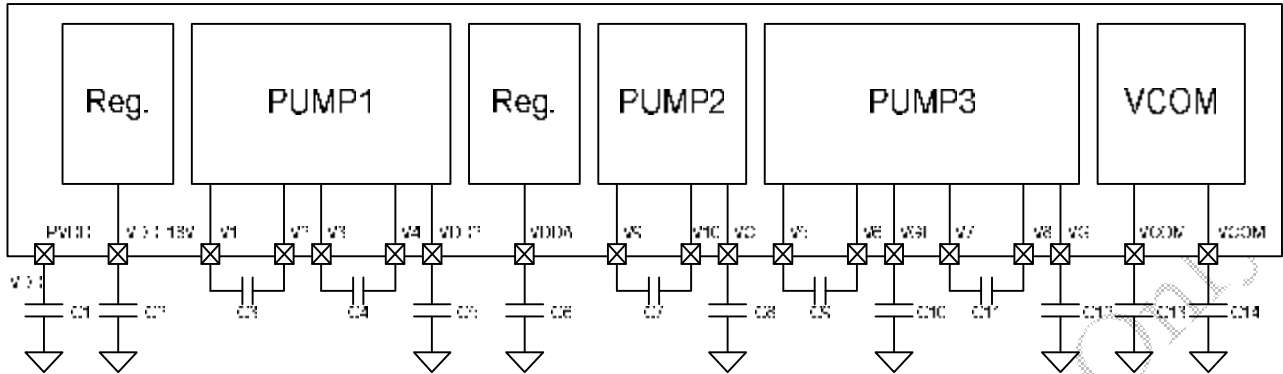

Component	Recommended Value	Voltage Proof
C2	1uF	>10V
C9,C11	1uF	>16V
C3,C4,C7	2.2uF	>6V
C10,C12	2.2uF	>16V
C5,C6,C8,C13,C14	4.7uF	>10V

Remarks:

1. PVDD is connected to VDD externally
2. VDD2 is generated from VDD by internal charge pump when EXT_PWR = "High" (default)
 When VDD=2.5V, please set PWR_SEL=L, VDD2=3x VDD
 When VDD=3.3V, please set PWR_SEL=H, VDD2=2x VDD
3. VDD2 can be applied externally only when application board can provide 4.8V~6V supply along with VDD.
 When setting EXT_PWR = "Low", VDD2 is supplied by external power supply. .

8. 3-WIRE COMMAND FORMAT

8.1 3-Wire Command Format

RAW: Read/Write mode control bit. *RAW*=1; read mode. *RAW*=0; write mode.

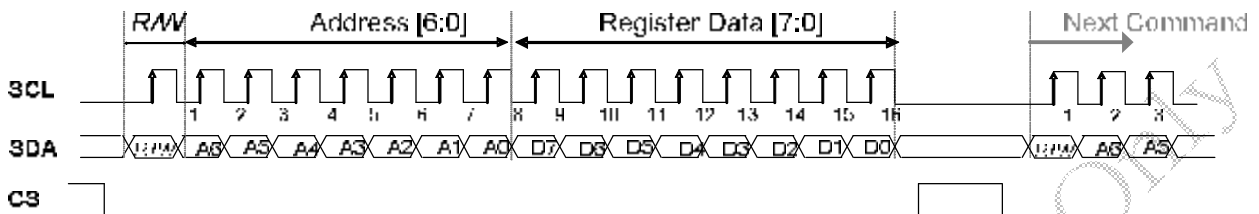

- Each serial command consists of 16 bits of data which is loaded one bit a time at the rising edge of serial clock SCL.
- Command loading operation starts from the falling edge of CS and is completed at the next rising edge of CS.
- The serial control block is operational after power on reset, but commands are established by the VSYNC signal. If command is transferred multiple times for the same register, the last command before the VSYNC signal is valid.
- If less than 16 bits of SCL are input while CS is low, the transferred data is ignored.
- If 16 bits or more of SCL are input while CS is low, the previous 16 bits of transferred data before the rising edge of CS pulse are valid data.
- Serial block operates with the SCL clock
- Serial data can be accepted in the power save mode.

8.2 Register summary

No.	Register Address								Register Data (Default)							
	R/W	A6	A5	A4	A3	A2	A1	A0	D7	D6	D5	D4	D3	D2	D1	D0
R0	0	0	0	0	0	0	0	0	X	VDIR (1)	HDIR (1)	X	X	X	X	X
R1	0	0	0	0	0	0	0	1	X	X	X	X	GRB (1)	SHDB2 (1)	SHDB1 (0)	DISP (0)
R2	0	0	0	0	0	0	1	0	CONTRAST (40h)							
R3	0	0	0	0	0	0	1	1	X	SUB-CONTRAST_R (40h)						
R4	0	0	0	0	0	1	0	0	X	SUB-CONTRAST_B (40h)						
R5	0	0	0	0	0	1	0	1	BRIGHTNESS (40h)							
R6	0	0	0	0	0	1	1	0	X	SUB-BRIGHTNESS_R (40h)						
R7	0	0	0	0	0	1	1	1	X	SUB-BRIGHTNESS_B (40h)						
R8	0	0	0	0	1	0	0	0	H_BLANKING (2Bh)							
R9	0	0	0	0	1	0	0	1	VDPOL (1)	HDPOL (1)	V_BLANKING (0Ch)					
R10	0	0	0	0	1	0	1	0	SYNC (0)	DCLKpol (1)	CP3_FREQ (10)	CP2_FREQ (10)	CP1_FREQ (11)			
R11	0	0	0	0	1	0	1	1	LED_VFB (00)	BL_DRV (00)	DRV_FERQ (00)	PFM_DUTY (10)				
R12	0	0	0	0	1	1	0	0	LED_ON_CYCLE (0111)				LED_ON_RATIO (1111)			
R13	0	0	0	0	1	1	0	1	X	OP (1XX)			X	X	X	X
R14	0	0	0	0	1	1	1	0	X	X	X	LC_TYPE (0XX)			X	X
R15	0	0	0	0	1	1	1	1	X	X	VGH_SEL (1XX)			VGL_SEL (1XX)		
R16	0	0	0	1	0	0	0	0	AUTO_DECT (1)	X		INVERSION (00)		X	X	X
R17	0	0	0	1	0	0	0	1	X	VCOMH (57h)						
R18	0	0	0	1	0	0	1	0	X	VCOML (1Bh)						
R23	0	0	0	1	0	1	1	1	X	X	X	X	X	GM_V2 (011)		

R24	0	0	0	1	1	0	0	0	X	X	X	X	X	GM_V3 (011)
R25	0	0	0	1	1	0	0	1	X	X	X	X	X	GM_V4 (011)
R26	0	0	0	1	1	0	1	0	X	X	X	X	X	GM_V5 (011)
R27	0	0	0	1	0	0	1	1	X	X	X	X	X	GM_V6 (011)
R28	0	0	0	1	0	1	0	0	X	X	X	X	X	GM_V7 (011)
R29	0	0	0	1	0	1	0	1	X	X	X	X	X	GM_V8 (011)
R30	0	0	0	1	0	1	1	0	X	X	X	X	X	GM_V9 (011)

X: reversed, please set to '0'

Note:

1. When GRB is low, all registers reset to default values
2. Serial commands are executed at next VSYNC signal

8.3 Register description

8.3.1 R0: Direction setting

Address	Bit	Description		Default
00000000	[6:5]	B6(VDIR)	Vertical shift direction setting	01100000b
		B5(HDIR)	Horizontal shift direction setting	

B6	Function(VDIR)
0	Shift from down to up, Last line = G1<G2<...<G543<G544 = First line
1	Shift from up to down, First line = G1->G2->...->G543->G544 = Last line (Default)

B5	Function(HDIR)
0	Shift from right to left, Last data = S1<S2<...<S719<S720 = First data
1	Shift from left to right, First data = S1->S2->...->S719->S720 = Last data (Default)

8.3.2 R1: GRB、SHDB2、SHDB1、DISP

Address	Bit	Description		Default
00000001	[6:0]	B3(GRB)	Register reset setting	00001100b
		B2(SHDB2)	Charge pump shutdown setting	
		B1(SHDB1)	DC-DC converter shutdown setting	
		B0(DISP)	Display control / standby mode setting	

B3	Function(GRB)
0	Reset all registers to default value
1	Normal operation (Default)

B2	Function(SHDB2)
0	Charge pump is off
1	Charge pump is controlled by DISP and power on/off sequence (Default)

B1	Function(SHDB1)
0	DC-DC converter is off (Default)
1	DC-DC converter is controlled by DISP and power on/off sequence

B0	Function(DISP)
0	Standby mode (Display OFF). Timing control, driver, and DC/DC converter are off and all output are High-Z.. (Default)
1	Normal operation (Display ON)

8.3.3 R2: CONTRAST

Address	Bit	Description	Default
00000010	[7:0]	RGB contrast level setting, the gain changes (1/64) / bit	0100000b

B7-B0	Contrast Gain
00h	0
40h	1(default)
FFh	3.984

8.3.4 R3: SUB-CONTRAST_R

Address	Bit	Description	Default
00000011	[6:0]	R sub-contrast level setting, the gain changes (1/256) / bit	0100000b

B6-B0	Sub-Contrast_R Gain
00h	0.75
40h	1(default)
7Fh	1.246

8.3.5 R4: SUB-CONTRAST_B

Address	Bit	Description	Default
00000100	[6:0]	B sub-contrast level setting, the gain changes (1/256) / bit	0100000b

B6-B0	Sub-Contrast_B Gain
00h	0.75
40h	1(default)
7Fh	1.246

8.3.6 R5: BRIGHTNESS

Address	Bit	Description	Default
00000101	[7:0]	RGB bright level setting, setting accuracy : 1 step / bit	0100000b

B7-B0	Brightness Setting
00h	Dark (-64)
40h	Center (0)(Default)
FFh	Bright (+191)

8.3.7 R6: SUB- BRIGHTNESS _R

Address	Bit	Description	Default
00000110	[6:0]	R sub-brightness level setting, setting accuracy : 1 step / bit	01000000b

B6-B0	Sub-Contrast_R Gain
00h	Dark (-64)
40h	Center (0)(Default)
7Fh	Bright (+63)

8.3.8 R7: SUB- BRIGHTNESS _B

Address	Bit	Description	Default
00000111	[6:0]	B sub-brightness level setting, setting accuracy : 1 step / bit	01000000b

B6-B0	Sub-Contrast_B Gain
00h	Dark (-64)
40h	Center (0)(Default)
7Fh	Bright (+63)

8.3.9 R8: H_BLANKING

Address	Bit	Description	Default
00001000	[7:0]	H back porch setting	00101011b

B7-B0	H_BLANKING (Unit: DCLK)
00h	0
2Bh	43(default)
FFh	255

Note: H_BLANKING function will be disabled in SYNC-DE mode.

8.3.10 R9: VDPOL、HDPOL、V_BLANKING

Address	Bit	Description	Default	
00001001	[7:0]	B7(VDPOL)	VSYNC polarity selection	11001100b
		B6(HDPOL)	HSYNC polarity selection	
		B5-B0(V_BLANKING)	V back porch setting	

B7	Function(VDPOL)
0	Positive polarity
1	Negative polarity (Default)

B6	Function(HDPOL)
0	Positive polarity
1	Negative polarity (Default)

Relationship of HDPOL/VDPOL/CLKPOL

- HDPOL=1, VDPOL=1, CLKPOL=1

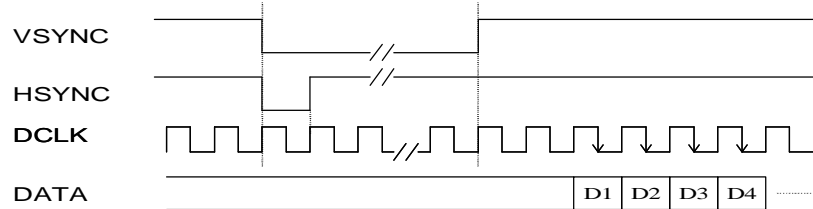

- HDPOL=0, VDPOL=0, CLKPOL=0

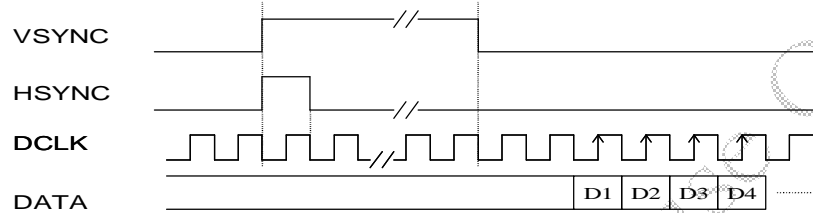

B5-B0	V_BLANKING (Unit: H)
00h	0
0Ch	12(Default)
3Fh	63

Note: V_BLANKING function will be disabled in SYNC-DE mode.

8.3.11 R10: SYNC、DCLKPOL、CP3_FREQ、CP2_FREQ、CP1_FREQ

Address	Bit	Description	Default	
00001010	[7:0]	B7(SYNC)	SYNC and SYNC-DE mode selection	01101011b
		B6(DCLKPOL)	DCLK polarity selection	
		B5-B4(PUMP3 Frequency)	Charge Pump3 Frequency Setting	
		B3-B2(PUMP2 Frequency)	Charge Pump2 Frequency Setting	
		B1-B0(PUMP1 Frequency)	Charge Pump1 Frequency Setting	

B7	Function(SYNC)
0	SYNC-DE Mode(Default)
1	SYNC Mode

B6	Function(DCLKPOL)
0	Positive polarity
1	Negative polarity (Default)

CP1,2,3_FREQ	Function(Charge Pump Frequency)	
0	0	1/2*HSYNC Freq.
0	1	1*HSYNC Freq.
1	0	2*HSYNC Freq.
1	1	4*HSYNC Freq.

8.3.12 R11: LED_VFB、BL_DRV、DRV_FREQ、PFM_DUTY

Address	Bit	Description		Default
00001011	[7:0]	B7-B6(LED_VFB)	Adjust VFB and IDRIV level.	00000010b
		B5-B4(BL_DRV)	Backlight driving capability setting	
		B3-B2(DRV_FREQ)	DRV signal frequency setting	
		B1-B0(PFM_DUTY)	PFM duty cycle selection for back light power converter	

		DC2DC Feedback Voltage(V)
B7	B6	Function(LED_VFB)
0	0	0.6 V+0.04V (Default)
0	1	0.75V+0.04V
1	0	0.45V+0.04V
1	1	0.3V+0.04V

B5	B4	Function(BL_DRV)
0	0	Normal capability (Default)
0	1	4 times the Normal capability
1	0	8 times the Normal capability
1	1	12 times the Normal capability

B3	B2	Function(DRV_FREQ)
0	0	DCLK / 32 (Default)
0	1	DCLK / 64
1	0	DCLK / 128
1	1	DCLK / 256

B1	B0	Function(PFM_DUTY)
0	0	50 %
0	1	60 %
1	0	65 % (Default)
1	1	70 %

8.3.13 R12: LED_ON_CYCLE、LED_ON_RATIO

Address	Bit	Description		Default
00001001	[7:0]	B7-B4 (LED_ON_CYCLE)	Set the cycle of enable signal , and we can use it to adjust brightness of the LEDs.	01111111b
		B3-B0 (LED_ON_RATIO)	Set the active ratio of enable signal, and we can use it to adjust brightness of the LEDs	

B7	B6	B5	B4	Function (LED_ON_CYCLE)
0	0	0	0	1
0	0	0	1	2
0	0	1	0	3
0	0	1	1	4
0	1	0	0	5
0	1	0	1	6
0	1	1	0	7
0	1	1	1	8 (Default)
1	0	0	0	9
1	0	0	1	10
1	0	1	0	11
1	0	1	1	12
1	1	0	0	13
1	1	0	1	14
1	1	1	0	15
1	1	1	1	16

B3	B2	B1	B0	Function (LED_ON_RATIO)
0	0	0	0	1/16
0	0	0	1	2/16
0	0	1	0	3/16
0	0	1	1	4/16
0	1	0	0	5/16
0	1	0	1	6/16
0	1	1	0	7/16
0	1	1	1	8/16
1	0	0	0	9/16
1	0	0	1	10/16
1	0	1	0	11/16
1	0	1	1	12/16
1	1	0	0	13/16
1	1	0	1	14/16
1	1	1	0	15/16
1	1	1	1	16/16(Default)

8.3.14 R13: OP

Address	Bit	Description		Default
00001011	[6:4]	B6-B4(OP)	Source output driving capability selection	0100000b

			DAC output driving capacity
B6	B5	B4	Function(OP)
0	0	0	-25%
0	0	1	Normal (satisfy output settling time 2.6us)
0	1	0	+25% (satisfy output settling time 2.2us)
0	1	1	+50%
1	0	0	Controlled by input pin OP0, OP1 (Default)

8.3.15 R14: LC_TYPE

Address	Bit	Description		Default
00100000	[4:2]	B4-B2(LC_TYPE)	LC type selection	0000000b

B4	B3	B2	Function(LC_TYPE)
0	X	X	Setting by input pins TN_TYPE and MVA_TN (Default)
1	0	0	TN_Mode2.
1	0	1	TN_Mode1.
1	1	0	MVA_Mode2.
1	1	1	MVA_Mode1.

8.3.16 R15:VGH_SEL · VGL_SEL

Address	Bit	Description		Default
00001111	[5:0]	B5-B3(VGH_SEL)	VGH_SEL : VGH voltage Selection	00100100b
		B2-B0(VGL_SEL)	VGL voltage Selection	

			Unit: V
B5	B4	B3	Function(VGH_SEL)
0	0	0	VGL +2
0	0	1	VGL +3
0	1	0	VGL +4
0	1	1	VGL +5
1	X	X	Auto Select by LC_TYPE(Default)

			Unit: V
B2	B1	B0	Function(VGL_SEL)
0	0	0	-7
0	0	1	-8
0	1	0	-9
0	1	1	-10
1	X	X	Auto Select by LC_TYPE(Default)

8.3.17 R16: INVERSION

Address	Bit	Description		Default
01001111	[7:3]	B7(AUTO_DETECT)	SYNC and SYNC-DE mode auto detection setting	1000000b
		B4-B3 (INVERSION)	Line/Column/Dot/Frame inversion control bit	

B7	Function(Auto Detect)
0	Disable SYNC/SYNC+DE auto detect (Pin selection)
1	Enable SYNC/SYNC+DE auto detection (Default)

B4	B3	Function (INVERSION)
0	0	Line inversion (Default)
0	1	Column inversion
1	0	Dot inversion
1	1	Frame inversion

8.3.18 R17: VCOMH

Address	Bit	Description		Default
00010001	[6:0]	B6-B0(VCOMH)	VCOMH level adjustment	1010111b

B6-B0	VCOMH level(Unit: V)
00h	3.26
25h	4
57h	5 (default)
7Fh	5.8

8.3.19 R18: VCOML

Address	Bit	Description		Default
00010010	[6:0]	B6-B0(VCOML)	VCOML level adjustment	0110010b

B6-B0	VCOML level(Unit: V)
00h	-0.2
32h	-1.2 (default)
5Ah	-2
7Fh	-2

8.3.20 R23: GM_V2

Address	Bit	Description		Default
001_0111	[2:0]	B2-B0(GM_V2)	Gamma selection	011b

8.3.21 R24: GM_V3

Address	Bit	Description		Default
001_1000	[2:0]	B2-B0(GM_V3)	Gamma selection	011b

8.3.22 R25: GM_V4

Address	Bit	Description		Default
001_1001	[2:0]	B2-B0(GM_V4)	Gamma selection	011b

8.3.23 R26: GM_V5

Address	Bit	Description		Default
001_1010	[2:0]	B2-B0(GM_V5)	Gamma selection	011b

8.3.24 R27: GM_V6

Address	Bit	Description		Default
001_1011	[2:0]	B2-B0(GM_V6)	Gamma selection	011b

8.3.25 R28: GM_V7

Address	Bit	Description		Default
001_1100	[2:0]	B2-B0(GM_V7)	Gamma selection	011b

8.3.26 R29: GM_V8

Address	Bit	Description		Default
0001_1101	[2:0]	B2-B0(GM_V8)	Gamma selection	011b

8.3.27 R30: GM_V9

Address	Bit	Description		Default
001_1110	[2:0]	B2-B0(GM_V9)	Gamma selection	011b

9. ELECTRICAL SPECIFICATIONS

9.1 Absolute Maximum Ratings

Rating	Symbol	Value		Unit
Digital supply voltage	VDDIO	-0.3	to +4.5	V
Power Supply for Pump	VDD	-0.3	to +4.5	V
Analog supply voltage	VDD2	-0.3	to +7.0	V
Storage temperature	T _{STG}	-55	to 100	°C
Operating temperature	T _A	-30	to 85	°C

Note: Stresses beyond those given in the Absolute Maximum Rating table may cause operational errors or damage to the device. For normal operational conditions see AC/DC Electrical Characteristics.

9.2 DC Characteristics

9.2.1 Recommended Operating Range

Item	Symbol	Min.	Typ.	Max.	Unit	Conditions
Charge Pump Supply Voltage	PVDD	3	3.3	3.6	V	PWR_SEL=H
	PVDD	2.25	2.5	3	V	PWR_SEL=L
Digital Supply Voltage	VDD	3	3.3	3.6	V	PWR_SEL=H
	VDD	2.25	2.5	3	V	PWR_SEL=L
Digital Interface Supply Voltage	VDDIO	1.65	1.8	VDD	V	
Digital Input Voltage	Din	0	-	VDDIO	V	
OTP Supply Voltage	V_OTP	7.4	7.5	7.6	V	
VCOM AC Voltage	VCOMH- VCOML	3.46	-	6.2	V	

9.2.2 DC Characteristics for Digital Circuit

VDDIO=1.8V, VDD = 3.3V, AVDD = 6V, AGND = 0V, T_A = -20°C to 80°C

Item	Symbol	Min.	Typ.	Max.	Unit	Conditions
Low Level Input Voltage	V _{il}	GND	-	0.3xVDDIO	V	
High Level Input Voltage	V _{ih}	0.7xVDDIO	-	VDDIO	uA	
High Level Output Voltage	V _{oh}	VDDIO-0.4	-	VDDIO	ohm	
Low Level Output Voltage	V _{ol}	GND	-	GND+0.4	uA	
Input Leakage Current	I _{il}			±1.0		
Pull High/Low Resistor	R _p	-	100K	-	ohm	
Digital Stand-by Current	I _{st}		5.0	20	uA	DCLK stopped, Output Hi-Z
Digital Operating Current	I _{cc}	-	4	-	mA	DCLK = 9MHz

9.2.3 DC Characteristics for Analog Circuit

VDDIO=1.8V, VDD = 3.3V, AVDD = 6V, AGND = 0V, T_A = -20°C to 80°C

Item	Symbol	Min.	Typ.	Max.	Unit	Conditions
Analog Supply Voltage	VDD2		5		V	
Positive High-voltage power	VGH	9	15	16	V	No Load. By VGH_SEL setting.
Negative High-voltage power	VGL	-11	-10	-7	V	No Load. By VGL_SEL setting.
VCOMH Output Level	VCOMH	3.26		5.8	V	By VCOMH setting.
VCOML Output Level	VCOML	-2		-0.2	V	By VCOML setting
DRV Output Voltage	VDRV	0	-	VDD	V	
DCDC Feed Back Voltage	VFB	0.28	0.6	0.79	V	By LED_VFB setting
Base Drive Current	IDRV	-	20	25	mA	By LED_VFB setting
Output Voltage Deviation	Vod	-	±20	±35	mV	V _O = 0.15V ~ 0.5V, 3.45V~3.8V
		-	±15	±20		V _O = 0.5V ~ 3.45V
Output Dynamic Range	Vdr	0.2	-	5.3		MVA Mode
		0.15		4.8		TN Mode
VCOM Low Level Output Current	IOL _{FRP}		-10		mA	VCOM AC output = 0.5V
VCOM High Level Output Current	IOH _{FRP}		-10		mA	VCOM AC output = 5.7V
Analog Standby Current	I _{last}	-	-	20	uA	
Analog Operation Current	IDD	-	5.0	-	mA	Without panel loading

9.3 AC Characteristics

VDDIO=1.8V, VDD = 3.3V, AVDD = 6V, AGND = 0V, T_A = -20°C to 80°C

Item	Symbol	Min.	Typ.	Max.	Unit	Conditions
CLK pulse duty	T _{cw}	40	50	60	%	
Hsync width	T _{hw}	1.0	-	-	DCLK	
Hsync period	T _h	55	60	65	us	
Vsync setup time	T _{vst}	12	-	-	ns	
Vsync hold time	T _{vhd}	12	-	-	ns	
Hsync setup time	T _{hst}	12	-	-	ns	
Hsync hold time	T _{hhd}	12	-	-	ns	
Data set-up time	T _{dsu}	12	-	-	ns	
Data hold time	T _{dhd}	12	-	-	ns	
DE set-up time	T _{desu}	12	-	-	ns	
DE hold time	T _{dehd}	12	-	-	ns	
SD output stable time	T _{st}	-	10	12	us	
GD output rise and fall time	T _{gst}	-	500	1000	ns	
Serial communication						
Delay between CSB and Vsync	T _{cv}	1			us	
CS input setup time	T _{s0}	50			ns	
Serial data input setup time	T _{s1}	50			ns	
CS input hold time	T _{h0}	50			ns	
Serial data input hold time	T _{h1}	50			ns	
SCL pulse high width	T _{wh1}	50			ns	

SCL pulse low width	Tw1	50			ns	
CS pulse high width	Tw2	400			ns	

9.4 AC Timing Diagram

9.4.1 Clock and Data Input Timing Diagram

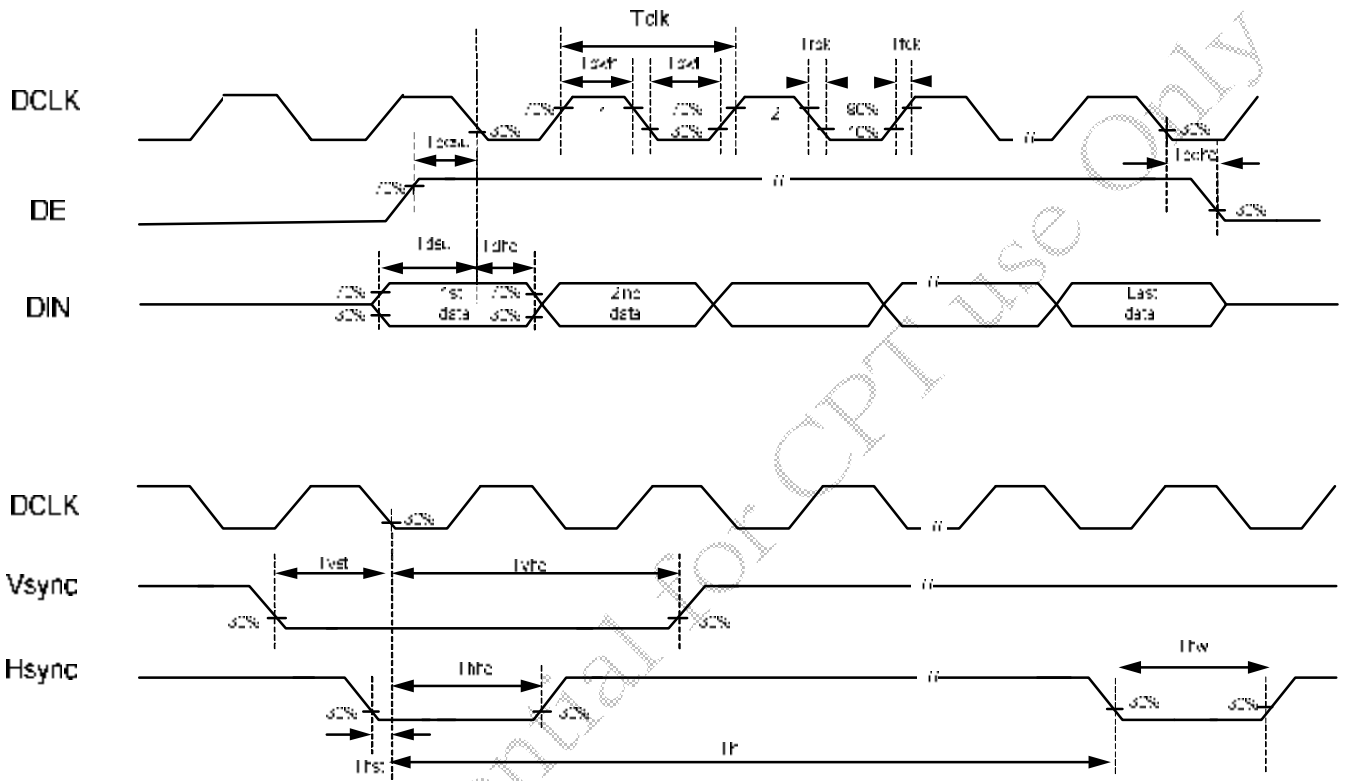

9.4.2 3-Wire Communication Timing Diagram

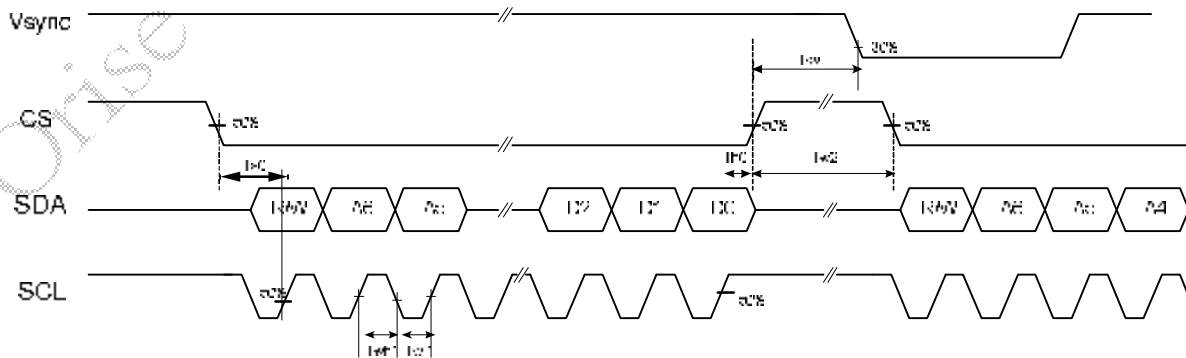

10. INPUT DATA FORMAT

10.1 Parallel RGB Data Format

10.1.1 Parallel RGB Input Timing Table

Item	Symbol	Min.	Typ.	Max.	Unit		
DCLK Frequency	Fclk	5	9	12	MHz		
DCLK Period	Tclk	83	110	200	ns		
Hsync	Period Time	Th	490	531	605	DCLK	
	Display Period	Thdisp		480		DCLK	
	Back Porch	Thbp	8	43		DCLK	By H_BLANKING setting
	Front Porch	Thfp	2	8		DCLK	
	Pulse Width	Thw	1			DCLK	
Vsync	Period Time	Tv	275	288	335	H	
	Display Period	Tvdisp		272		H	
	Back Porch	Tvbp	2	12		H	By V_BLANKING setting
	Front Porch	Tvfp	1	4		H	
	Pulse Width	Tvw	1	10		H	

10.1.2 SYNC Mode Timing Diagram

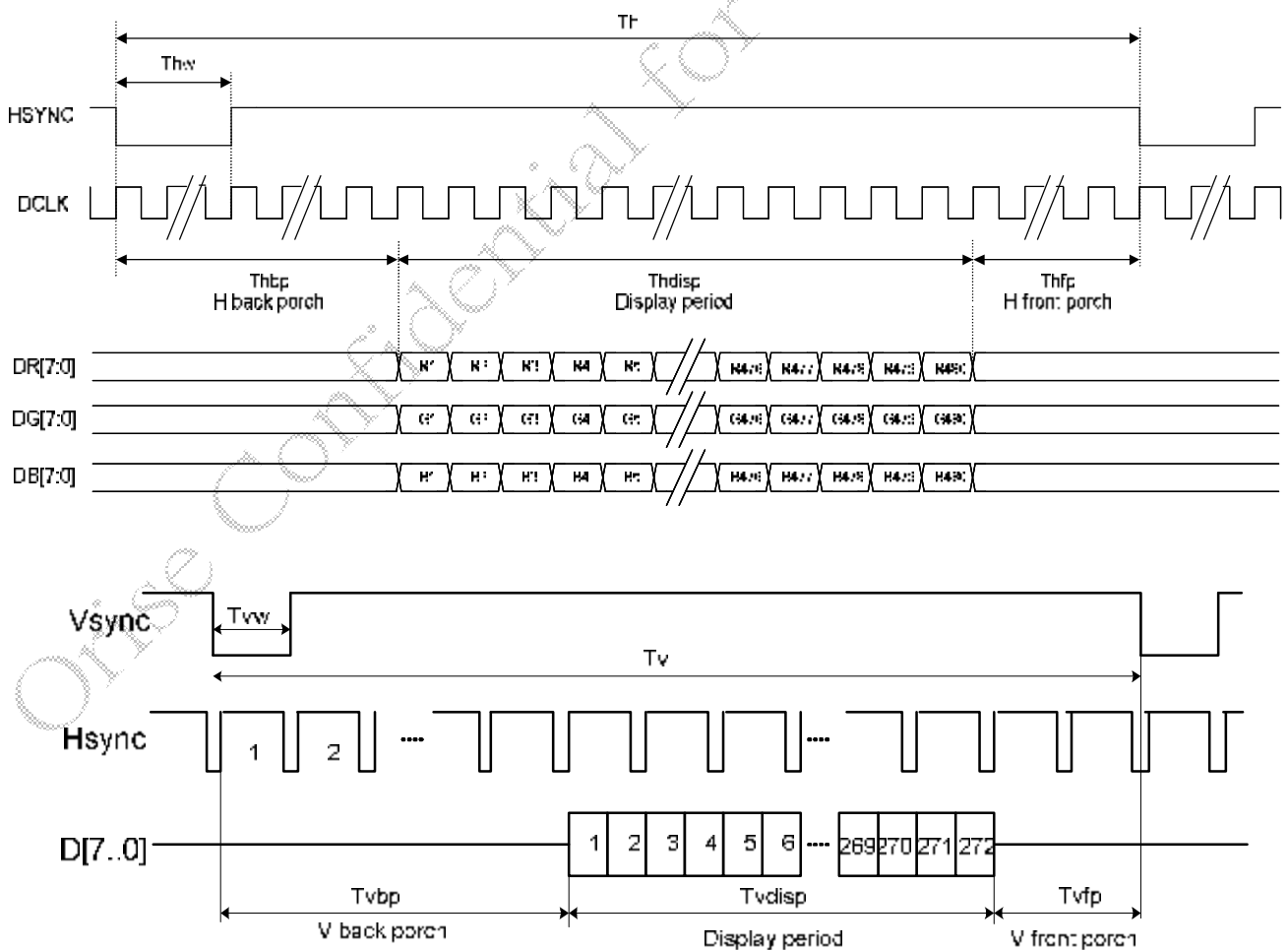

10.1.3 SYNC-DE Mode Timing Diagram

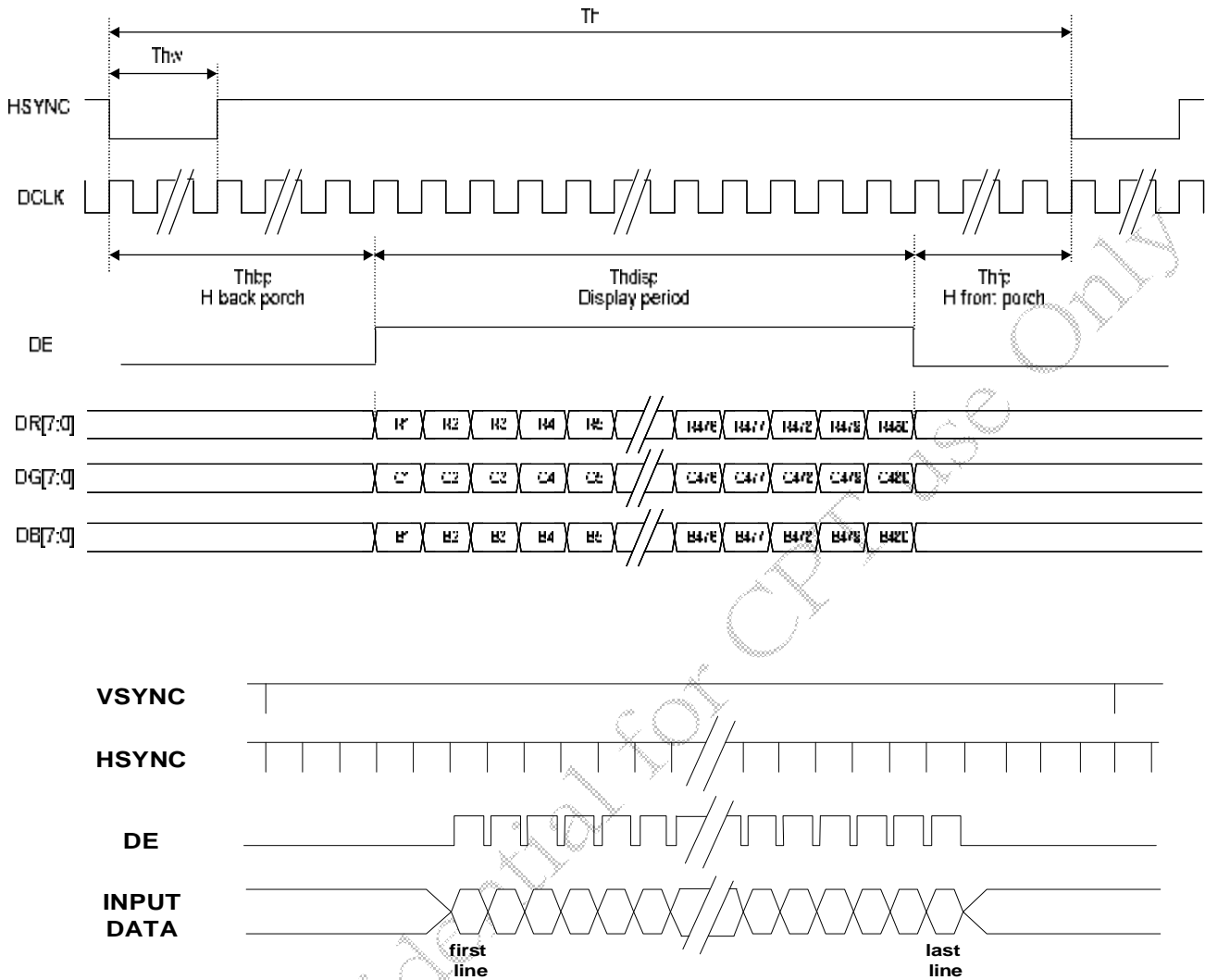

10.2 Serial 8-bit RGB Data Format

10.2.1 Serial 8-bit RGB Input Timing Table

Item	Symbol	Min.	Typ.	Max.	Unit		
DCLK Frequency	Fclk	24	27	30	MHz		
DCLK Period	Tclk	42	37	33	ns		
Hsync	Period Time	Th	1560	1716	1900	DCLK	
	Display Period	Thdisp		1440		DCLK	
	To 1 st Data Input	Thbp	108	129	255	DCLK	By H_BLANKING setting
	Front Porch	Thfp	12	168	205	DCLK	
	Pulse Width	Thw	1			DCLK	
Vsync	Period Time	Tv	274	288	335	H	
	Display Period	Tvdisp		272		H	
	Delay to 1 st Gate Output	Tvbp		12		H	By V_BLANKING setting
	Front Porch	Tvfp		3		H	
	Pulse Width	Tvw	1	10		H	

10.2.2 SYNC Mode Timing Diagram

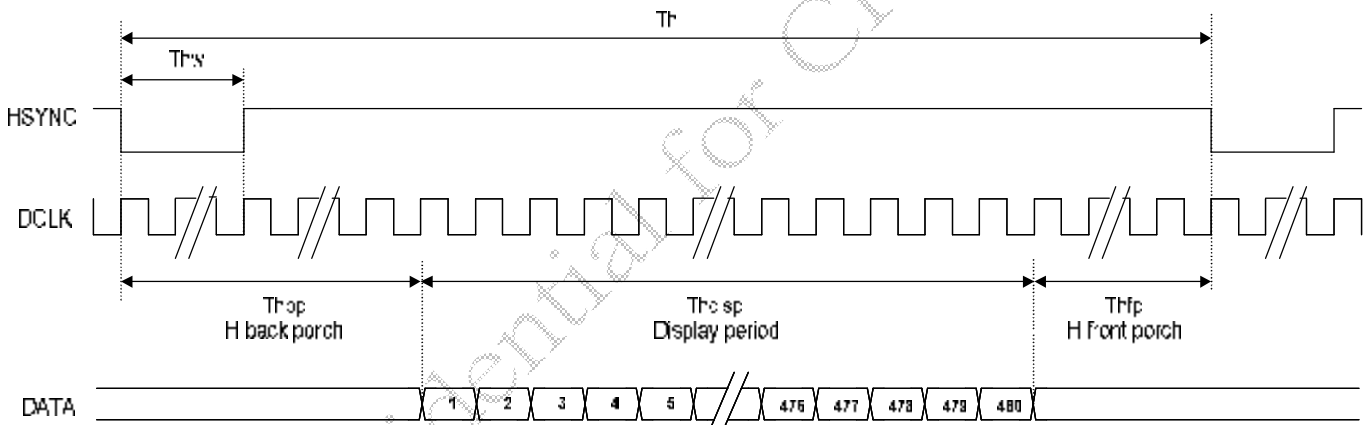

10.2.3 SYNC-DE Mode Timing Diagram

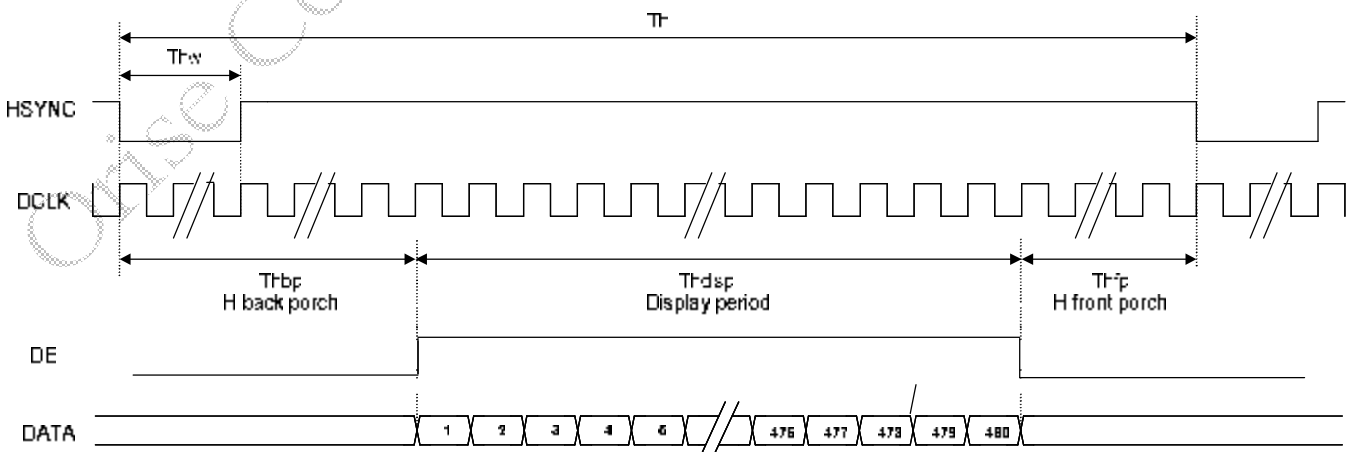

11. POWER ON/OFF SEQUENCE

11.1.1 Power On Sequence

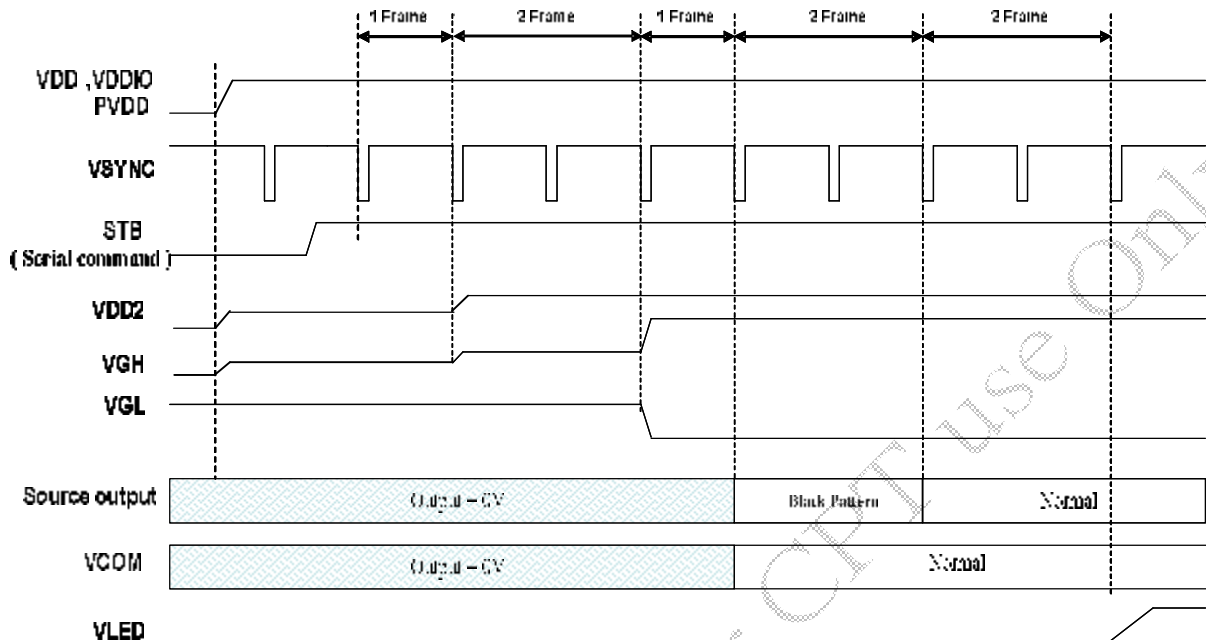

11.1.2 Power On Sequence

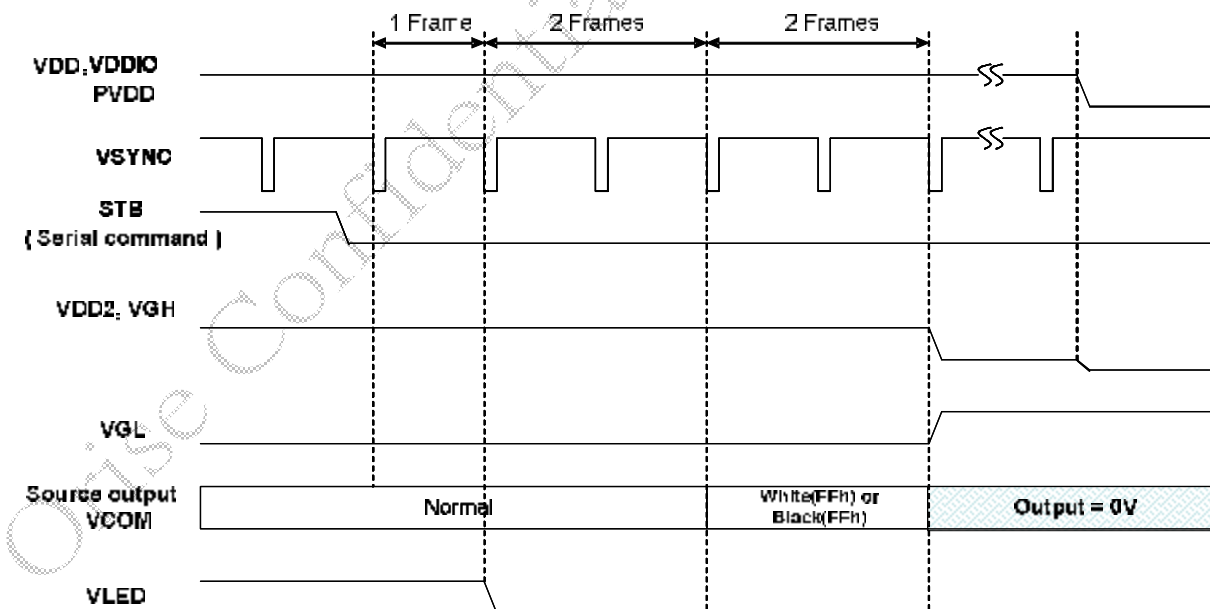

Note:

- When normally-black LC is used, please send black pattern to discharge the panel.
- When normally-white LC is applied, please send white pattern to discharge the panel.

12. OTP PROGRAM PROCEDURE

- Write VCOMH voltage to R17 [6:0] when the value is considered as the optimum for display quality.
- Write VCOML voltage to R18 [6:0] when the value is considered as the optimum for display quality.
- The endurance for OTA5180A NV memory is 2 times for VCOMH and VCOML.

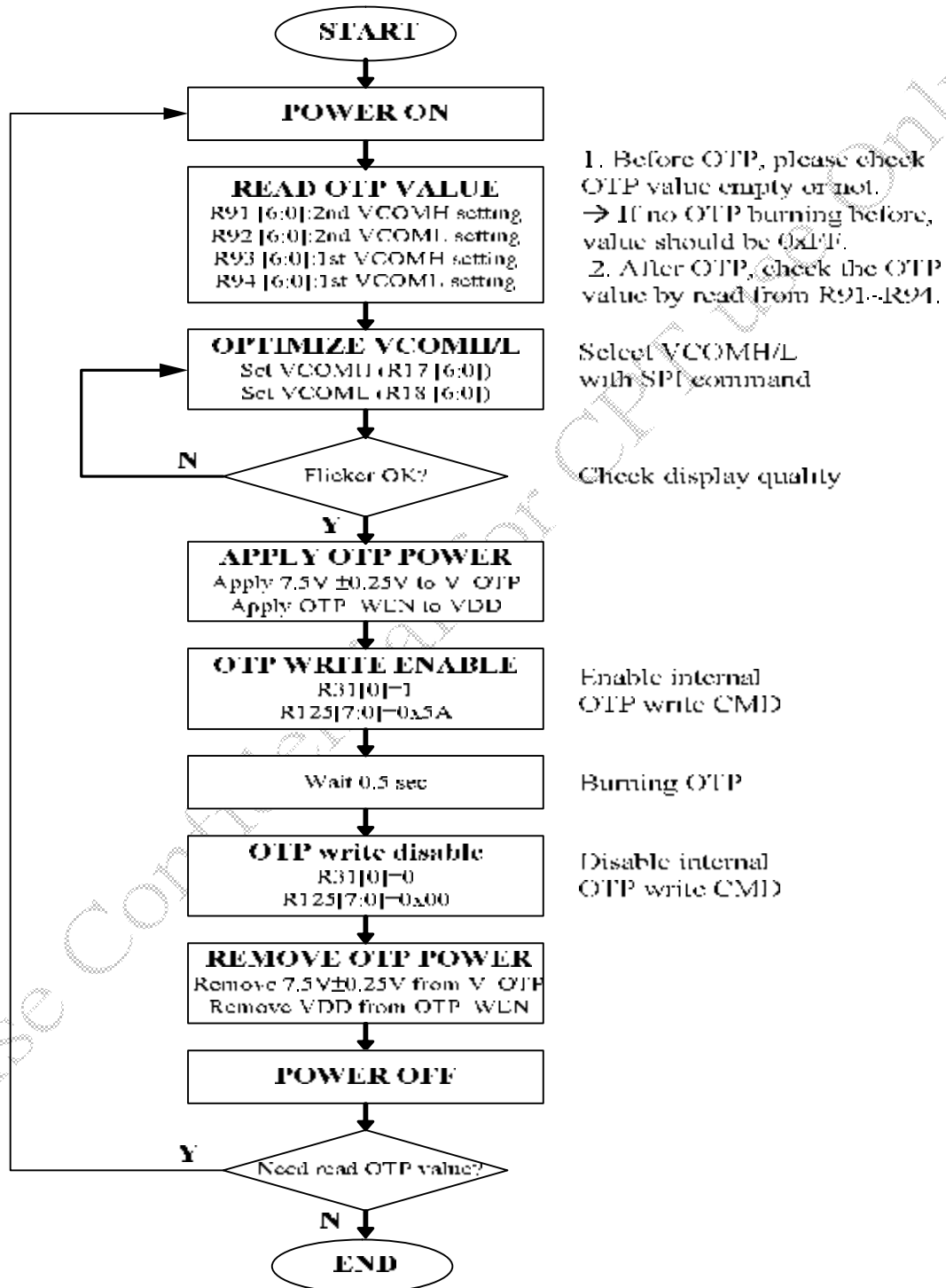

13. RECOMMENDED PANEL ROUTING RESISTANCE

The recommended wiring resistance values are given below. The wiring resistance values affect the current capability of the power supply blocks and thus must be designed within the given range.

	Pin Name	Value [unit: Ohm]
1	EXT_PWR	<100
2	V_OTP	<5
3	VCOMH	<10
4	VCOML	<10
5	VCOM	<5
6	FB	<100
7	DRV	<10
8	GND	<5
9	VDD_18V	<10
10	VDDIO	<10
11	VDD	<5
12	VSYN	<100
13	HSYN	<100
14	DCLK	<100
15	VDPOL	<100
16	VDPOL	<100
17	HDPOL	<100
18	DCLKPOL	<100
19	DATA_RB	<100
20	DE	<100
21	MVA_TN	<100
22	TN_TYPE	<100
23	PARA_SERI	<100
24	OTP_WEN	<100
25	HDIR	<100
26	VDIR	<100
27	OP0	<100
28	OP1	<100
29	CS	<100
30	SDA	<100
31	SCL	<100
32	DISP	<100
33	LVR_EN	<100
34	GRB	<100
35	SYNC	<100
36	PWR_SEL	<100

37	DR7-DR0	<100
38	DG7-DG0	<100
39	DB7-DB0	<100
40	VDDA	<5
41	AGND	<5
42	VCL	<10
43	V10	<10
44	V9	<10
45	VDD2	<5
46	PGND	<3
47	V1	<5
48	V2	<5
49	V3	<5
50	V4	<5
51	PVDD	<3
52	V5	<10
53	V6	<10
54	VGH	<10
55	V7	<10
56	V8	<10
57	VGL	<10

14. APPLICATION CIRCUIT for DC-DC CONVERTER

The PWM controller provides high efficient boost power supply circuit control that generates the power of LED back light and Level Shift. The boost converter uses a Power transistor to provide maximum efficiency and to minimize the number of external components. A precision 0.6V

reference voltage with $\pm 0.01V$ Hysteresis is included. The DCDC converter of OTA5180A is designed to support maximum 6 LED applications.

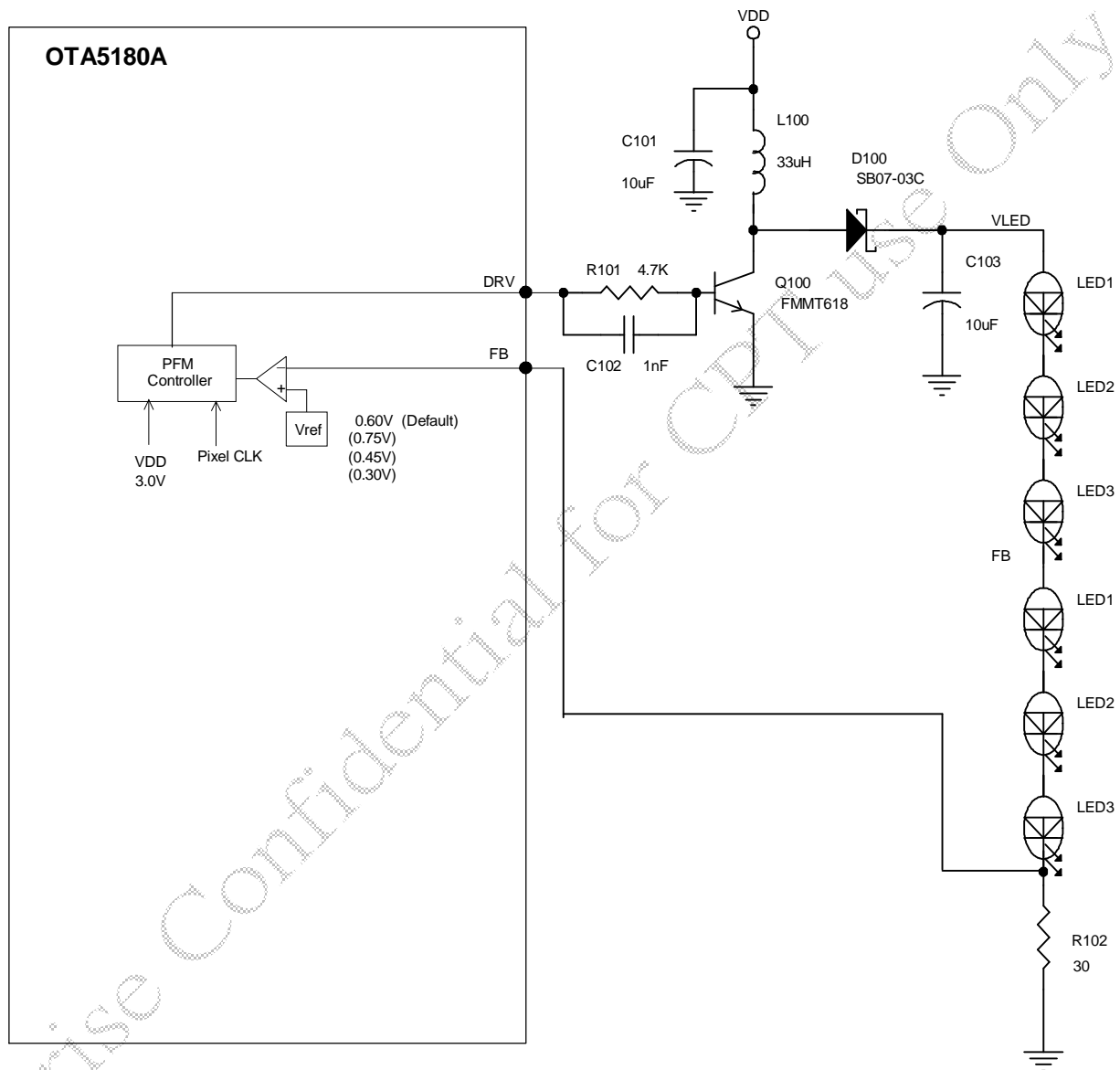

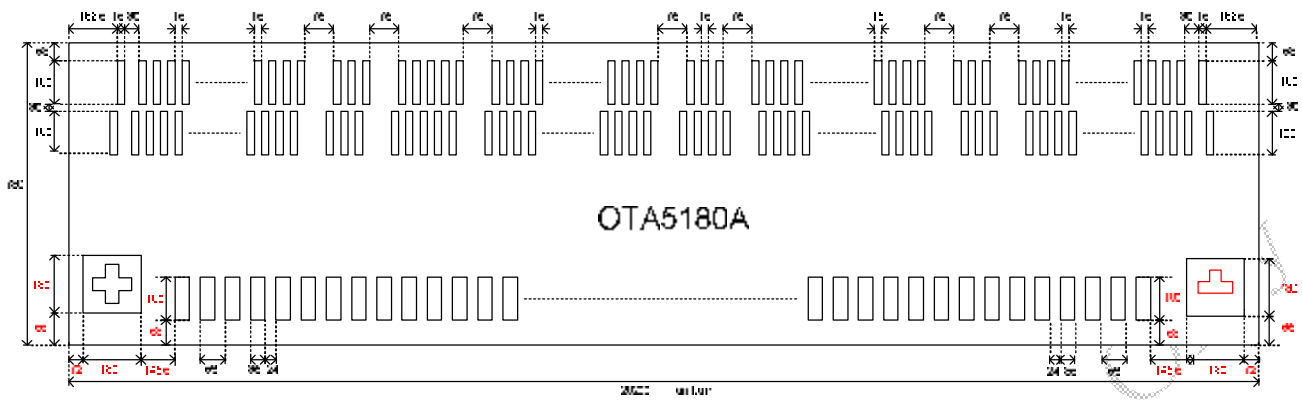
15. CHIP INFORMATION
15.1 PAD Assignment

Note: Dimension includes scribe line

15.2 PAD Dimension

Item	PAD No.	Size		Unit
		X	Y	
Chip Size	-	20200	730	μm
Chip thickness	-	300 ± 25		
Pad pitch	1~331	59		
	332~1628	15		
Pad size	1~331	35	100	
	332~1628	15	100	

Note: Chip size includes scribe line.

15.3 Bump Characteristic

Item	Standard	Note
Bump Hardness	75HV	± 25HV
Bump Height	15μm	± 3μm
Co-planarity (in Chip)	$R \leq 2\mu\text{m}$	R : Max-Min
Roughness (in Bump)	$R \leq 2\mu\text{m}$	R : Max-Min
Bump Size	"X" ± 3μm x "Y" ± 3μm	X/Y: bump size
Shear Force	>4.5g/mil ²	

15.4 Pad Locations

PAD NO.	PAD Name	X	Y
1	DUM1	-9735	-257
2	VSS	-9676	-257
3	EXT_PWR	-9617	-257
4	EXT_PWR	-9558	-257
5	VSS	-9499	-257
6	V_OTP	-9440	-257
7	V_OTP	-9381	-257
8	V_OTP	-9322	-257
9	V_OTP	-9263	-257
10	V_OTP	-9204	-257
11	V_OTP	-9145	-257
12	VSS	-9086	-257
13	COMPASS_LO	-9027	-257
14	COMPASS_LO	-8968	-257
15	COMPASS_LO	-8909	-257
16	COMPASS_LO	-8850	-257
17	VSS	-8791	-257
18	VCOMH	-8732	-257
19	VCOMH	-8673	-257
20	VCOMH	-8614	-257
21	VCOMH	-8555	-257
22	VCOMH	-8496	-257
23	VCOMH	-8437	-257
24	VCOML	-8378	-257
25	VCOML	-8319	-257
26	VCOML	-8260	-257
27	VCOML	-8201	-257
28	VCOML	-8142	-257
29	VCOML	-8083	-257
30	VCOM	-8024	-257
31	VCOM	-7965	-257
32	VCOM	-7906	-257
33	VCOM	-7847	-257
34	VCOM	-7788	-257
35	VCOM	-7729	-257
36	VSS	-7670	-257
37	FB	-7611	-257
38	FB	-7552	-257
39	VSS	-7493	-257
40	DRV	-7434	-257
41	DRV	-7375	-257
42	DRV	-7316	-257
43	DRV	-7257	-257
44	TEST0	-7198	-257
45	TEST0	-7139	-257
46	GND	-7080	-257
47	GND	-7021	-257
48	GND	-6962	-257
49	GND	-6903	-257
50	GND	-6844	-257
51	GND	-6785	-257
52	GND	-6726	-257
53	GND	-6667	-257
54	VDD_18V	-6608	-257
55	VDD_18V	-6549	-257

PAD NO.	PAD Name	X	Y
56	VDD_18V	-6490	-257
57	VDD_18V	-6431	-257
58	VDD_18V	-6372	-257
59	VDD_18V	-6313	-257
60	VDDIO	-6254	-257
61	VDDIO	-6195	-257
62	VDDIO	-6136	-257
63	VDDIO	-6077	-257
64	VDDIO	-6018	-257
65	VDDIO	-5959	-257
66	VDD	-5900	-257
67	VDD	-5841	-257
68	VDD	-5782	-257
69	VDD	-5723	-257
70	VDD	-5664	-257
71	VDD	-5605	-257
72	VDD	-5546	-257
73	VDD	-5487	-257
74	TEST1	-5428	-257
75	VSYNC	-5369	-257
76	VSYNC	-5310	-257
77	HSYNC	-5251	-257
78	HSYNC	-5192	-257
79	DCLK	-5133	-257
80	DCLK	-5074	-257
81	VDPOL	-5015	-257
82	VDPOL	-4956	-257
83	HDPOL	-4897	-257
84	HDPOL	-4838	-257
85	DCLKPOL	-4779	-257
86	DCLKPOL	-4720	-257
87	DATA_RB	-4661	-257
88	DATA_RB	-4602	-257
89	DE	-4543	-257
90	DE	-4484	-257
91	MVA_TN	-4425	-257
92	MVA_TN	-4366	-257
93	TN_TYPE	-4307	-257
94	TN_TYPE	-4248	-257
95	PARA_SERI	-4189	-257
96	PARA_SERI	-4130	-257
97	OTP_WEN	-4071	-257
98	OTP_WEN	-4012	-257
99	HDIR	-3953	-257
100	HDIR	-3894	-257
101	VDIR	-3835	-257
102	VDIR	-3776	-257
103	OP0	-3717	-257
104	OP0	-3658	-257
105	OP1	-3599	-257
106	OP1	-3540	-257
107	CS	-3481	-257
108	CS	-3422	-257
109	SDA	-3363	-257
110	SDA	-3304	-257

PAD NO.	PAD Name	X	Y
111	SCL	-3245	-257
112	SCL	-3186	-257
113	DISP	-3127	-257
114	DISP	-3068	-257
115	LVR_EN	-3009	-257
116	LVR_EN	-2950	-257
117	GRB	-2891	-257
118	GRB	-2832	-257
119	SYNC	-2773	-257
120	SYNC	-2714	-257
121	PWR_SEL	-2655	-257
122	PWR_SEL	-2596	-257
123	TEST2	-2537	-257
124	TEST2	-2478	-257
125	VSS	-2419	-257
126	DR7	-2360	-257
127	DR7	-2301	-257
128	DR6	-2242	-257
129	DR6	-2183	-257
130	DR5	-2124	-257
131	DR5	-2065	-257
132	DR4	-2006	-257
133	DR4	-1947	-257
134	DR3	-1888	-257
135	DR3	-1829	-257
136	DR2	-1770	-257
137	DR2	-1711	-257
138	DR1	-1652	-257
139	DR1	-1593	-257
140	DR0	-1534	-257
141	DR0	-1475	-257
142	DG7	-1416	-257
143	DG7	-1357	-257
144	DG6	-1298	-257
145	DG6	-1239	-257
146	DG5	-1180	-257
147	DG5	-1121	-257
148	DG4	-1062	-257
149	DG4	-1003	-257
150	DG3	-944	-257
151	DG3	-885	-257
152	DG2	-826	-257
153	DG2	-767	-257
154	DG1	-708	-257
155	DG1	-649	-257
156	DG0	-590	-257
157	DG0	-531	-257
158	DB7	-472	-257
159	DB7	-413	-257
160	DB6	-354	-257
161	DB6	-295	-257
162	DB5	-236	-257
163	DB5	-177	-257
164	DB4	-118	-257
165	DB4	-59	-257

PAD NO.	PAD Name	X	Y
166	DB3	0	-257
167	DB3	59	-257
168	DB2	118	-257
169	DB2	177	-257
170	DB1	236	-257
171	DB1	295	-257
172	DB0	354	-257
173	DB0	413	-257
174	TEST3	472	-257
175	TEST4	531	-257
176	TEST5	590	-257
177	TEST6	649	-257
178	TEST7	708	-257
179	TEST8	767	-257
180	TEST9	826	-257
181	TEST10	885	-257
182	TEST11	944	-257
183	TEST12	1003	-257
184	TEST13	1062	-257
185	TEST14	1121	-257
186	TEST15	1180	-257
187	TEST_S0	1239	-257
188	TEST_S1	1298	-257
189	TEST_S2	1357	-257
190	TEST16	1416	-257
191	TEST17	1475	-257
192	TEST18	1534	-257
193	TEST19	1593	-257
194	TEST20	1652	-257
195	TEST21	1711	-257
196	TEST22	1770	-257
197	TEST23	1829	-257
198	TEST24	1888	-257
199	TEST25	1947	-257
200	TEST26	2006	-257
201	TEST27	2065	-257
202	TEST28	2124	-257
203	TEST29	2183	-257
204	TEST30	2242	-257
205	TEST31	2301	-257
206	TEST32	2360	-257
207	TEST33	2419	-257
208	TEST34	2478	-257
209	TEST35	2537	-257
210	TEST36	2596	-257
211	VDDA	2655	-257
212	VDDA	2714	-257
213	VDDA	2773	-257
214	VDDA	2832	-257
215	VDDA	2891	-257
216	VDDA	2950	-257
217	AGND	3009	-257
218	AGND	3068	-257
219	AGND	3127	-257
220	AGND	3186	-257
221	AGND	3245	-257
222	AGND	3304	-257

PAD NO.	PAD Name	X	Y
223	VSS	3363	-257
224	VCL	3422	-257
225	VCL	3481	-257
226	VCL	3540	-257
227	VCL	3599	-257
228	VCL	3658	-257
229	VCL	3717	-257
230	V10	3776	-257
231	V10	3835	-257
232	V10	3894	-257
233	V10	3953	-257
234	V10	4012	-257
235	V10	4071	-257
236	V9	4130	-257
237	V9	4189	-257
238	V9	4248	-257
239	V9	4307	-257
240	V9	4366	-257
241	V9	4425	-257
242	VDD2	4484	-257
243	VDD2	4543	-257
244	VDD2	4602	-257
245	VDD2	4661	-257
246	VDD2	4720	-257
247	VDD2	4779	-257
248	VDD2	4838	-257
249	VDD2	4897	-257
250	PGND	4956	-257
251	PGND	5015	-257
252	PGND	5074	-257
253	PGND	5133	-257
254	PGND	5192	-257
255	PGND	5251	-257
256	PGND	5310	-257
257	PGND	5369	-257
258	COMPASS_R0	5428	-257
259	COMPASS_R0	5487	-257
260	COMPASS_R0	5546	-257
261	COMPASS_R0	5605	-257
262	V1	5664	-257
263	V1	5723	-257
264	V1	5782	-257
265	V1	5841	-257
266	V1	5900	-257
267	V1	5959	-257
268	V2	6018	-257
269	V2	6077	-257
270	V2	6136	-257
271	V2	6195	-257
272	V2	6254	-257
273	V2	6313	-257
274	V3	6372	-257
275	V3	6431	-257
276	V3	6490	-257
277	V3	6549	-257
278	V3	6608	-257
279	V3	6667	-257

PAD NO.	PAD Name	X	Y
280	V4	6726	-257
281	V4	6785	-257
282	V4	6844	-257
283	V4	6903	-257
284	V4	6962	-257
285	V4	7021	-257
286	PVDD	7080	-257
287	PVDD	7139	-257
288	PVDD	7198	-257
289	PVDD	7257	-257
290	PVDD	7316	-257
291	PVDD	7375	-257
292	PVDD	7434	-257
293	PVDD	7493	-257
294	V5	7552	-257
295	V5	7611	-257
296	V5	7670	-257
297	V5	7729	-257
298	V5	7788	-257
299	V5	7847	-257
300	V6	7906	-257
301	V6	7965	-257
302	V6	8024	-257
303	V6	8083	-257
304	V6	8142	-257
305	V6	8201	-257
306	VGH	8260	-257
307	VGH	8319	-257
308	VGH	8378	-257
309	VGH	8437	-257
310	VGH	8496	-257
311	VGH	8555	-257
312	V7	8614	-257
313	V7	8673	-257
314	V7	8732	-257
315	V7	8791	-257
316	V7	8850	-257
317	V7	8909	-257
318	V8	8968	-257
319	V8	9027	-257
320	V8	9086	-257
321	V8	9145	-257
322	V8	9204	-257
323	V8	9263	-257
324	VGL	9322	-257
325	VGL	9381	-257
326	VGL	9440	-257
327	VGL	9499	-257
328	VGL	9558	-257
329	VGL	9617	-257
330	VSS	9676	-257
331	DUM2	9735	-257
332	DUM3	9945	127
333	DUM4	9930	257
334	G2	9900	127
335	G4	9885	257
336	G6	9870	127

PAD NO.	PAD Name	X	Y
337	G8	9855	257
338	G10	9840	127
339	G12	9825	257
340	G14	9810	127
341	G16	9795	257
342	G18	9780	127
343	G20	9765	257
344	G22	9750	127
345	G24	9735	257
346	G26	9720	127
347	G28	9705	257
348	G30	9690	127
349	G32	9675	257
350	G34	9660	127
351	G36	9645	257
352	G38	9630	127
353	G40	9615	257
354	G42	9600	127
355	G44	9585	257
356	G46	9570	127
357	G48	9555	257
358	G50	9540	127
359	G52	9525	257
360	G54	9510	127
361	G56	9495	257
362	G58	9480	127
363	G60	9465	257
364	G62	9450	127
365	G64	9435	257
366	G66	9420	127
367	G68	9405	257
368	G70	9390	127
369	G72	9375	257
370	G74	9360	127
371	G76	9345	257
372	G78	9330	127
373	G80	9315	257
374	G82	9300	127
375	G84	9285	257
376	G86	9270	127
377	G88	9255	257
378	G90	9240	127
379	G92	9225	257
380	G94	9210	127
381	G96	9195	257
382	G98	9180	127
383	G100	9165	257
384	G102	9150	127
385	G104	9135	257
386	G106	9120	127
387	G108	9105	257
388	G110	9090	127
389	G112	9075	257
390	G114	9060	127
391	G116	9045	257
392	G118	9030	127
393	G120	9015	257

PAD NO.	PAD Name	X	Y
394	G122	9000	127
395	G124	8985	257
396	G126	8970	127
397	G128	8955	257
398	G130	8940	127
399	G132	8925	257
400	G134	8910	127
401	G136	8895	257
402	G138	8880	127
403	G140	8865	257
404	G142	8850	127
405	G144	8835	257
406	G146	8820	127
407	G148	8805	257
408	G150	8790	127
409	G152	8775	257
410	G154	8760	127
411	G156	8745	257
412	G158	8730	127
413	G160	8715	257
414	G162	8700	127
415	G164	8685	257
416	G166	8670	127
417	G168	8655	257
418	G170	8640	127
419	G172	8625	257
420	G174	8610	127
421	G176	8595	257
422	G178	8580	127
423	G180	8565	257
424	G182	8550	127
425	G184	8535	257
426	G186	8520	127
427	G188	8505	257
428	G190	8490	127
429	G192	8475	257
430	G194	8460	127
431	G196	8445	257
432	G198	8430	127
433	G200	8415	257
434	G202	8400	127
435	G204	8385	257
436	G206	8370	127
437	G208	8355	257
438	G210	8340	127
439	G212	8325	257
440	G214	8310	127
441	G216	8295	257
442	G218	8280	127
443	G220	8265	257
444	G222	8250	127
445	G224	8235	257
446	G226	8220	127
447	G228	8205	257
448	G230	8190	127
449	G232	8175	257
450	G234	8160	127

PAD NO.	PAD Name	X	Y
451	G236	8145	257
452	G238	8130	127
453	G240	8115	257
454	G242	8100	127
455	G244	8085	257
456	G246	8070	127
457	G248	8055	257
458	G250	8040	127
459	G252	8025	257
460	G254	8010	127
461	G256	7995	257
462	G258	7980	127
463	G260	7965	257
464	G262	7950	127
465	G264	7935	257
466	G266	7920	127
467	G268	7905	257
468	G270	7890	127
469	G272	7875	257
470	G274	7860	127
471	G276	7845	257
472	G278	7830	127
473	G280	7815	257
474	G282	7800	127
475	G284	7785	257
476	G286	7770	127
477	G288	7755	257
478	G290	7740	127
479	G292	7725	257
480	G294	7710	127
481	G296	7695	257
482	G298	7680	127
483	G300	7665	257
484	G302	7650	127
485	G304	7635	257
486	G306	7620	127
487	G308	7605	257
488	G310	7590	127
489	G312	7575	257
490	G314	7560	127
491	G316	7545	257
492	G318	7530	127
493	G320	7515	257
494	G322	7500	127
495	G324	7485	257
496	G326	7470	127
497	G328	7455	257
498	G330	7440	127
499	G332	7425	257
500	G334	7410	127
501	G336	7395	257
502	G338	7380	127
503	G340	7365	257
504	G342	7350	127
505	G344	7335	257
506	G346	7320	127
507	G348	7305	257

PAD NO.	PAD Name	X	Y
508	G350	7290	127
509	G352	7275	257
510	G354	7260	127
511	G356	7245	257
512	G358	7230	127
513	G360	7215	257
514	G362	7200	127
515	G364	7185	257
516	G366	7170	127
517	G368	7155	257
518	G370	7140	127
519	G372	7125	257
520	G374	7110	127
521	G376	7095	257
522	G378	7080	127
523	G380	7065	257
524	G382	7050	127
525	G384	7035	257
526	G386	7020	127
527	G388	7005	257
528	G390	6990	127
529	G392	6975	257
530	G394	6960	127
531	G396	6945	257
532	G398	6930	127
533	G400	6915	257
534	G402	6900	127
535	G404	6885	257
536	G406	6870	127
537	G408	6855	257
538	G410	6840	127
539	G412	6825	257
540	G414	6810	127
541	G416	6795	257
542	G418	6780	127
543	G420	6765	257
544	G422	6750	127
545	G424	6735	257
546	G426	6720	127
547	G428	6705	257
548	G430	6690	127
549	G432	6675	257
550	G434	6660	127
551	G436	6645	257
552	G438	6630	127
553	G440	6615	257
554	G442	6600	127
555	G444	6585	257
556	G446	6570	127
557	G448	6555	257
558	G450	6540	127
559	G452	6525	257
560	G454	6510	127
561	G456	6495	257
562	G458	6480	127
563	G460	6465	257
564	G462	6450	127

PAD NO.	PAD Name	X	Y
565	G464	6435	257
566	G466	6420	127
567	G468	6405	257
568	G470	6390	127
569	G472	6375	257
570	G474	6360	127
571	G476	6345	257
572	G478	6330	127
573	G480	6315	257
574	G482	6300	127
575	G484	6285	257
576	G486	6270	127
577	G488	6255	257
578	G490	6240	127
579	G492	6225	257
580	G494	6210	127
581	G496	6195	257
582	G498	6180	127
583	G500	6165	257
584	G502	6150	127
585	G504	6135	257
586	G506	6120	127
587	G508	6105	257
588	G510	6090	127
589	G512	6075	257
590	G514	6060	127
591	G516	6045	257
592	G518	6030	127
593	G520	6015	257
594	G522	6000	127
595	G524	5985	257
596	G526	5970	127
597	G528	5955	257
598	G530	5940	127
599	G532	5925	257
600	G534	5910	127
601	G536	5895	257
602	G538	5880	127
603	G540	5865	257
604	G542	5850	127
605	G544	5835	257
606	COMPASS_R1	5760	127
607	COMPASS_R1	5745	257
608	COMPASS_R1	5730	127
609	COMPASS_R1	5715	257
610	COMPASS_R1	5700	127
611	COMPASS_R1	5685	257
612	S1	5610	127
613	S2	5595	257
614	S3	5580	127
615	S4	5565	257
616	S5	5550	127
617	S6	5535	257
618	S7	5520	127
619	S8	5505	257
620	S9	5490	127
621	S10	5475	257

PAD NO.	PAD Name	X	Y
622	S11	5460	127
623	S12	5445	257
624	S13	5430	127
625	S14	5415	257
626	S15	5400	127
627	S16	5385	257
628	S17	5370	127
629	S18	5355	257
630	S19	5340	127
631	S20	5325	257
632	S21	5310	127
633	S22	5295	257
634	S23	5280	127
635	S24	5265	257
636	S25	5250	127
637	S26	5235	257
638	S27	5220	127
639	S28	5205	257
640	S29	5190	127
641	S30	5175	257
642	S31	5160	127
643	S32	5145	257
644	S33	5130	127
645	S34	5115	257
646	S35	5100	127
647	S36	5085	257
648	S37	5070	127
649	S38	5055	257
650	S39	5040	127
651	S40	5025	257
652	S41	5010	127
653	S42	4995	257
654	S43	4980	127
655	S44	4965	257
656	S45	4950	127
657	S46	4935	257
658	S47	4920	127
659	S48	4905	257
660	S49	4890	127
661	S50	4875	257
662	S51	4860	127
663	S52	4845	257
664	S53	4830	127
665	S54	4815	257
666	S55	4800	127
667	S56	4785	257
668	S57	4770	127
669	S58	4755	257
670	S59	4740	127
671	S60	4725	257
672	S61	4710	127
673	S62	4695	257
674	S63	4680	127
675	S64	4665	257
676	S65	4650	127
677	S66	4635	257
678	S67	4620	127

PAD NO.	PAD Name	X	Y
679	S68	4605	257
680	S69	4590	127
681	S70	4575	257
682	S71	4560	127
683	S72	4545	257
684	S73	4530	127
685	S74	4515	257
686	S75	4500	127
687	S76	4485	257
688	S77	4470	127
689	S78	4455	257
690	S79	4440	127
691	S80	4425	257
692	S81	4410	127
693	S82	4395	257
694	S83	4380	127
695	S84	4365	257
696	S85	4350	127
697	S86	4335	257
698	S87	4320	127
699	S88	4305	257
700	S89	4290	127
701	S90	4275	257
702	S91	4260	127
703	S92	4245	257
704	S93	4230	127
705	S94	4215	257
706	S95	4200	127
707	S96	4185	257
708	S97	4170	127
709	S98	4155	257
710	S99	4140	127
711	S100	4125	257
712	S101	4110	127
713	S102	4095	257
714	S103	4080	127
715	S104	4065	257
716	S105	4050	127
717	S106	4035	257
718	S107	4020	127
719	S108	4005	257
720	S109	3990	127
721	S110	3975	257
722	S111	3960	127
723	S112	3945	257
724	S113	3930	127
725	S114	3915	257
726	S115	3900	127
727	S116	3885	257
728	S117	3870	127
729	S118	3855	257
730	S119	3840	127
731	S120	3825	257
732	S121	3810	127
733	S122	3795	257
734	S123	3780	127
735	S124	3765	257

PAD NO.	PAD Name	X	Y
736	S125	3750	127
737	S126	3735	257
738	S127	3720	127
739	S128	3705	257
740	S129	3690	127
741	S130	3675	257
742	S131	3660	127
743	S132	3645	257
744	S133	3630	127
745	S134	3615	257
746	S135	3600	127
747	S136	3585	257
748	S137	3570	127
749	S138	3555	257
750	S139	3540	127
751	S140	3525	257
752	S141	3510	127
753	S142	3495	257
754	S143	3480	127
755	S144	3465	257
756	S145	3450	127
757	S146	3435	257
758	S147	3420	127
759	S148	3405	257
760	S149	3390	127
761	S150	3375	257
762	S151	3360	127
763	S152	3345	257
764	S153	3330	127
765	S154	3315	257
766	S155	3300	127
767	S156	3285	257
768	S157	3270	127
769	S158	3255	257
770	S159	3240	127
771	S160	3225	257
772	S161	3210	127
773	S162	3195	257
774	S163	3180	127
775	S164	3165	257
776	S165	3150	127
777	S166	3135	257
778	S167	3120	127
779	S168	3105	257
780	S169	3090	127
781	S170	3075	257
782	S171	3060	127
783	S172	3045	257
784	S173	3030	127
785	S174	3015	257
786	S175	3000	127
787	S176	2985	257
788	S177	2970	127
789	S178	2955	257
790	S179	2940	127
791	S180	2925	257
792	S181	2910	127

PAD NO.	PAD Name	X	Y
793	S182	2895	257
794	S183	2880	127
795	S184	2865	257
796	S185	2850	127
797	S186	2835	257
798	S187	2820	127
799	S188	2805	257
800	S189	2790	127
801	S190	2775	257
802	S191	2760	127
803	S192	2745	257
804	S193	2730	127
805	S194	2715	257
806	S195	2700	127
807	S196	2685	257
808	S197	2670	127
809	S198	2655	257
810	S199	2640	127
811	S200	2625	257
812	S201	2610	127
813	S202	2595	257
814	S203	2580	127
815	S204	2565	257
816	S205	2550	127
817	S206	2535	257
818	S207	2520	127
819	S208	2505	257
820	S209	2490	127
821	S210	2475	257
822	S211	2460	127
823	S212	2445	257
824	S213	2430	127
825	S214	2415	257
826	S215	2400	127
827	S216	2385	257
828	S217	2370	127
829	S218	2355	257
830	S219	2340	127
831	S220	2325	257
832	S221	2310	127
833	S222	2295	257
834	S223	2280	127
835	S224	2265	257
836	S225	2250	127
837	S226	2235	257
838	S227	2220	127
839	S228	2205	257
840	S229	2190	127
841	S230	2175	257
842	S231	2160	127
843	S232	2145	257
844	S233	2130	127
845	S234	2115	257
846	S235	2100	127
847	S236	2085	257
848	S237	2070	127
849	S238	2055	257

PAD NO.	PAD Name	X	Y
850	S239	2040	127
851	S240	2025	257
852	S241	2010	127
853	S242	1995	257
854	S243	1980	127
855	S244	1965	257
856	S245	1950	127
857	S246	1935	257
858	S247	1920	127
859	S248	1905	257
860	S249	1890	127
861	S250	1875	257
862	S251	1860	127
863	S252	1845	257
864	S253	1830	127
865	S254	1815	257
866	S255	1800	127
867	S256	1785	257
868	S257	1770	127
869	S258	1755	257
870	S259	1740	127
871	S260	1725	257
872	S261	1710	127
873	S262	1695	257
874	S263	1680	127
875	S264	1665	257
876	S265	1650	127
877	S266	1635	257
878	S267	1620	127
879	S268	1605	257
880	S269	1590	127
881	S270	1575	257
882	S271	1560	127
883	S272	1545	257
884	S273	1530	127
885	S274	1515	257
886	S275	1500	127
887	S276	1485	257
888	S277	1470	127
889	S278	1455	257
890	S279	1440	127
891	S280	1425	257
892	S281	1410	127
893	S282	1395	257
894	S283	1380	127
895	S284	1365	257
896	S285	1350	127
897	S286	1335	257
898	S287	1320	127
899	S288	1305	257
900	S289	1290	127
901	S290	1275	257
902	S291	1260	127
903	S292	1245	257
904	S293	1230	127
905	S294	1215	257
906	S295	1200	127

PAD NO.	PAD Name	X	Y
907	S296	1185	257
908	S297	1170	127
909	S298	1155	257
910	S299	1140	127
911	S300	1125	257
912	S301	1110	127
913	S302	1095	257
914	S303	1080	127
915	S304	1065	257
916	S305	1050	127
917	S306	1035	257
918	S307	1020	127
919	S308	1005	257
920	S309	990	127
921	S310	975	257
922	S311	960	127
923	S312	945	257
924	S313	930	127
925	S314	915	257
926	S315	900	127
927	S316	885	257
928	S317	870	127
929	S318	855	257
930	S319	840	127
931	S320	825	257
932	S321	810	127
933	S322	795	257
934	S323	780	127
935	S324	765	257
936	S325	750	127
937	S326	735	257
938	S327	720	127
939	S328	705	257
940	S329	690	127
941	S330	675	257
942	S331	660	127
943	S332	645	257
944	S333	630	127
945	S334	615	257
946	S335	600	127
947	S336	585	257
948	S337	570	127
949	S338	555	257
950	S339	540	127
951	S340	525	257
952	S341	510	127
953	S342	495	257
954	S343	480	127
955	S344	465	257
956	S345	450	127
957	S346	435	257
958	S347	420	127
959	S348	405	257
960	S349	390	127
961	S350	375	257
962	S351	360	127
963	S352	345	257

PAD NO.	PAD Name	X	Y
964	S353	330	127
965	S354	315	257
966	S355	300	127
967	S356	285	257
968	S357	270	127
969	S358	255	257
970	S359	240	127
971	S360	225	257
972	VSS	150	127
973	VSS	135	257
974	VSS	120	127
975	VSS	105	257
976	VSS	90	127
977	VSS	75	257
978	VSS	60	127
979	S361	-15	257
980	S362	-30	127
981	S363	-45	257
982	S364	-60	127
983	S365	-75	257
984	S366	-90	127
985	S367	-105	257
986	S368	-120	127
987	S369	-135	257
988	S370	-150	127
989	S371	-165	257
990	S372	-180	127
991	S373	-195	257
992	S374	-210	127
993	S375	-225	257
994	S376	-240	127
995	S377	-255	257
996	S378	-270	127
997	S379	-285	257
998	S380	-300	127
999	S381	-315	257
1000	S382	-330	127
1001	S383	-345	257
1002	S384	-360	127
1003	S385	-375	257
1004	S386	-390	127
1005	S387	-405	257
1006	S388	-420	127
1007	S389	-435	257
1008	S390	-450	127
1009	S391	-465	257
1010	S392	-480	127
1011	S393	-495	257
1012	S394	-510	127
1013	S395	-525	257
1014	S396	-540	127
1015	S397	-555	257
1016	S398	-570	127
1017	S399	-585	257
1018	S400	-600	127
1019	S401	-615	257
1020	S402	-630	127

PAD NO.	PAD Name	X	Y
1021	S403	-645	257
1022	S404	-660	127
1023	S405	-675	257
1024	S406	-690	127
1025	S407	-705	257
1026	S408	-720	127
1027	S409	-735	257
1028	S410	-750	127
1029	S411	-765	257
1030	S412	-780	127
1031	S413	-795	257
1032	S414	-810	127
1033	S415	-825	257
1034	S416	-840	127
1035	S417	-855	257
1036	S418	-870	127
1037	S419	-885	257
1038	S420	-900	127
1039	S421	-915	257
1040	S422	-930	127
1041	S423	-945	257
1042	S424	-960	127
1043	S425	-975	257
1044	S426	-990	127
1045	S427	-1005	257
1046	S428	-1020	127
1047	S429	-1035	257
1048	S430	-1050	127
1049	S431	-1065	257
1050	S432	-1080	127
1051	S433	-1095	257
1052	S434	-1110	127
1053	S435	-1125	257
1054	S436	-1140	127
1055	S437	-1155	257
1056	S438	-1170	127
1057	S439	-1185	257
1058	S440	-1200	127
1059	S441	-1215	257
1060	S442	-1230	127
1061	S443	-1245	257
1062	S444	-1260	127
1063	S445	-1275	257
1064	S446	-1290	127
1065	S447	-1305	257
1066	S448	-1320	127
1067	S449	-1335	257
1068	S450	-1350	127
1069	S451	-1365	257
1070	S452	-1380	127
1071	S453	-1395	257
1072	S454	-1410	127
1073	S455	-1425	257
1074	S456	-1440	127
1075	S457	-1455	257
1076	S458	-1470	127
1077	S459	-1485	257

PAD NO.	PAD Name	X	Y
1078	S460	-1500	127
1079	S461	-1515	257
1080	S462	-1530	127
1081	S463	-1545	257
1082	S464	-1560	127
1083	S465	-1575	257
1084	S466	-1590	127
1085	S467	-1605	257
1086	S468	-1620	127
1087	S469	-1635	257
1088	S470	-1650	127
1089	S471	-1665	257
1090	S472	-1680	127
1091	S473	-1695	257
1092	S474	-1710	127
1093	S475	-1725	257
1094	S476	-1740	127
1095	S477	-1755	257
1096	S478	-1770	127
1097	S479	-1785	257
1098	S480	-1800	127
1099	S481	-1815	257
1100	S482	-1830	127
1101	S483	-1845	257
1102	S484	-1860	127
1103	S485	-1875	257
1104	S486	-1890	127
1105	S487	-1905	257
1106	S488	-1920	127
1107	S489	-1935	257
1108	S490	-1950	127
1109	S491	-1965	257
1110	S492	-1980	127
1111	S493	-1995	257
1112	S494	-2010	127
1113	S495	-2025	257
1114	S496	-2040	127
1115	S497	-2055	257
1116	S498	-2070	127
1117	S499	-2085	257
1118	S500	-2100	127
1119	S501	-2115	257
1120	S502	-2130	127
1121	S503	-2145	257
1122	S504	-2160	127
1123	S505	-2175	257
1124	S506	-2190	127
1125	S507	-2205	257
1126	S508	-2220	127
1127	S509	-2235	257
1128	S510	-2250	127
1129	S511	-2265	257
1130	S512	-2280	127
1131	S513	-2295	257
1132	S514	-2310	127
1133	S515	-2325	257
1134	S516	-2340	127

PAD NO.	PAD Name	X	Y
1135	S517	-2355	257
1136	S518	-2370	127
1137	S519	-2385	257
1138	S520	-2400	127
1139	S521	-2415	257
1140	S522	-2430	127
1141	S523	-2445	257
1142	S524	-2460	127
1143	S525	-2475	257
1144	S526	-2490	127
1145	S527	-2505	257
1146	S528	-2520	127
1147	S529	-2535	257
1148	S530	-2550	127
1149	S531	-2565	257
1150	S532	-2580	127
1151	S533	-2595	257
1152	S534	-2610	127
1153	S535	-2625	257
1154	S536	-2640	127
1155	S537	-2655	257
1156	S538	-2670	127
1157	S539	-2685	257
1158	S540	-2700	127
1159	S541	-2715	257
1160	S542	-2730	127
1161	S543	-2745	257
1162	S544	-2760	127
1163	S545	-2775	257
1164	S546	-2790	127
1165	S547	-2805	257
1166	S548	-2820	127
1167	S549	-2835	257
1168	S550	-2850	127
1169	S551	-2865	257
1170	S552	-2880	127
1171	S553	-2895	257
1172	S554	-2910	127
1173	S555	-2925	257
1174	S556	-2940	127
1175	S557	-2955	257
1176	S558	-2970	127
1177	S559	-2985	257
1178	S560	-3000	127
1179	S561	-3015	257
1180	S562	-3030	127
1181	S563	-3045	257
1182	S564	-3060	127
1183	S565	-3075	257
1184	S566	-3090	127
1185	S567	-3105	257
1186	S568	-3120	127
1187	S569	-3135	257
1188	S570	-3150	127
1189	S571	-3165	257
1190	S572	-3180	127
1191	S573	-3195	257

PAD NO.	PAD Name	X	Y
1192	S574	-3210	127
1193	S575	-3225	257
1194	S576	-3240	127
1195	S577	-3255	257
1196	S578	-3270	127
1197	S579	-3285	257
1198	S580	-3300	127
1199	S581	-3315	257
1200	S582	-3330	127
1201	S583	-3345	257
1202	S584	-3360	127
1203	S585	-3375	257
1204	S586	-3390	127
1205	S587	-3405	257
1206	S588	-3420	127
1207	S589	-3435	257
1208	S590	-3450	127
1209	S591	-3465	257
1210	S592	-3480	127
1211	S593	-3495	257
1212	S594	-3510	127
1213	S595	-3525	257
1214	S596	-3540	127
1215	S597	-3555	257
1216	S598	-3570	127
1217	S599	-3585	257
1218	S600	-3600	127
1219	S601	-3615	257
1220	S602	-3630	127
1221	S603	-3645	257
1222	S604	-3660	127
1223	S605	-3675	257
1224	S606	-3690	127
1225	S607	-3705	257
1226	S608	-3720	127
1227	S609	-3735	257
1228	S610	-3750	127
1229	S611	-3765	257
1230	S612	-3780	127
1231	S613	-3795	257
1232	S614	-3810	127
1233	S615	-3825	257
1234	S616	-3840	127
1235	S617	-3855	257
1236	S618	-3870	127
1237	S619	-3885	257
1238	S620	-3900	127
1239	S621	-3915	257
1240	S622	-3930	127
1241	S623	-3945	257
1242	S624	-3960	127
1243	S625	-3975	257
1244	S626	-3990	127
1245	S627	-4005	257
1246	S628	-4020	127
1247	S629	-4035	257
1248	S630	-4050	127

PAD NO.	PAD Name	X	Y
1249	S631	-4065	257
1250	S632	-4080	127
1251	S633	-4095	257
1252	S634	-4110	127
1253	S635	-4125	257
1254	S636	-4140	127
1255	S637	-4155	257
1256	S638	-4170	127
1257	S639	-4185	257
1258	S640	-4200	127
1259	S641	-4215	257
1260	S642	-4230	127
1261	S643	-4245	257
1262	S644	-4260	127
1263	S645	-4275	257
1264	S646	-4290	127
1265	S647	-4305	257
1266	S648	-4320	127
1267	S649	-4335	257
1268	S650	-4350	127
1269	S651	-4365	257
1270	S652	-4380	127
1271	S653	-4395	257
1272	S654	-4410	127
1273	S655	-4425	257
1274	S656	-4440	127
1275	S657	-4455	257
1276	S658	-4470	127
1277	S659	-4485	257
1278	S660	-4500	127
1279	S661	-4515	257
1280	S662	-4530	127
1281	S663	-4545	257
1282	S664	-4560	127
1283	S665	-4575	257
1284	S666	-4590	127
1285	S667	-4605	257
1286	S668	-4620	127
1287	S669	-4635	257
1288	S670	-4650	127
1289	S671	-4665	257
1290	S672	-4680	127
1291	S673	-4695	257
1292	S674	-4710	127
1293	S675	-4725	257
1294	S676	-4740	127
1295	S677	-4755	257
1296	S678	-4770	127
1297	S679	-4785	257
1298	S680	-4800	127
1299	S681	-4815	257
1300	S682	-4830	127
1301	S683	-4845	257
1302	S684	-4860	127
1303	S685	-4875	257
1304	S686	-4890	127
1305	S687	-4905	257

PAD NO.	PAD Name	X	Y
1306	S688	-4920	127
1307	S689	-4935	257
1308	S690	-4950	127
1309	S691	-4965	257
1310	S692	-4980	127
1311	S693	-4995	257
1312	S694	-5010	127
1313	S695	-5025	257
1314	S696	-5040	127
1315	S697	-5055	257
1316	S698	-5070	127
1317	S699	-5085	257
1318	S700	-5100	127
1319	S701	-5115	257
1320	S702	-5130	127
1321	S703	-5145	257
1322	S704	-5160	127
1323	S705	-5175	257
1324	S706	-5190	127
1325	S707	-5205	257
1326	S708	-5220	127
1327	S709	-5235	257
1328	S710	-5250	127
1329	S711	-5265	257
1330	S712	-5280	127
1331	S713	-5295	257
1332	S714	-5310	127
1333	S715	-5325	257
1334	S716	-5340	127
1335	S717	-5355	257
1336	S718	-5370	127
1337	S719	-5385	257
1338	S720	-5400	127
1339	VSS	-5475	257
1340	VSS	-5490	127
1341	VSS	-5505	257
1342	VSS	-5520	127
1343	VSS	-5535	257
1344	VSS	-5550	127
1345	VSS	-5565	257
1346	VSS	-5580	127
1347	VSS	-5595	257
1348	VSS	-5610	127
1349	COMPASS_L1	-5685	257
1350	COMPASS_L1	-5700	127
1351	COMPASS_L1	-5715	257
1352	COMPASS_L1	-5730	127
1353	COMPASS_L1	-5745	257
1354	COMPASS_L1	-5760	127
1355	G543	-5835	257
1356	G541	-5850	127
1357	G539	-5865	257
1358	G537	-5880	127
1359	G535	-5895	257
1360	G533	-5910	127
1361	G531	-5925	257
1362	G529	-5940	127

PAD NO.	PAD Name	X	Y
1363	G527	-5955	257
1364	G525	-5970	127
1365	G523	-5985	257
1366	G521	-6000	127
1367	G519	-6015	257
1368	G517	-6030	127
1369	G515	-6045	257
1370	G513	-6060	127
1371	G511	-6075	257
1372	G509	-6090	127
1373	G507	-6105	257
1374	G505	-6120	127
1375	G503	-6135	257
1376	G501	-6150	127
1377	G499	-6165	257
1378	G497	-6180	127
1379	G495	-6195	257
1380	G493	-6210	127
1381	G491	-6225	257
1382	G489	-6240	127
1383	G487	-6255	257
1384	G485	-6270	127
1385	G483	-6285	257
1386	G481	-6300	127
1387	G479	-6315	257
1388	G477	-6330	127
1389	G475	-6345	257
1390	G473	-6360	127
1391	G471	-6375	257
1392	G469	-6390	127
1393	G467	-6405	257
1394	G465	-6420	127
1395	G463	-6435	257
1396	G461	-6450	127
1397	G459	-6465	257
1398	G457	-6480	127
1399	G455	-6495	257
1400	G453	-6510	127
1401	G451	-6525	257
1402	G449	-6540	127
1403	G447	-6555	257
1404	G445	-6570	127
1405	G443	-6585	257
1406	G441	-6600	127
1407	G439	-6615	257
1408	G437	-6630	127
1409	G435	-6645	257
1410	G433	-6660	127
1411	G431	-6675	257
1412	G429	-6690	127
1413	G427	-6705	257
1414	G425	-6720	127
1415	G423	-6735	257
1416	G421	-6750	127
1417	G419	-6765	257
1418	G417	-6780	127
1419	G415	-6795	257

PAD NO.	PAD Name	X	Y
1420	G413	-6810	127
1421	G411	-6825	257
1422	G409	-6840	127
1423	G407	-6855	257
1424	G405	-6870	127
1425	G403	-6885	257
1426	G401	-6900	127
1427	G399	-6915	257
1428	G397	-6930	127
1429	G395	-6945	257
1430	G393	-6960	127
1431	G391	-6975	257
1432	G389	-6990	127
1433	G387	-7005	257
1434	G385	-7020	127
1435	G383	-7035	257
1436	G381	-7050	127
1437	G379	-7065	257
1438	G377	-7080	127
1439	G375	-7095	257
1440	G373	-7110	127
1441	G371	-7125	257
1442	G369	-7140	127
1443	G367	-7155	257
1444	G365	-7170	127
1445	G363	-7185	257
1446	G361	-7200	127
1447	G359	-7215	257
1448	G357	-7230	127
1449	G355	-7245	257
1450	G353	-7260	127
1451	G351	-7275	257
1452	G349	-7290	127
1453	G347	-7305	257
1454	G345	-7320	127
1455	G343	-7335	257
1456	G341	-7350	127
1457	G339	-7365	257
1458	G337	-7380	127
1459	G335	-7395	257
1460	G333	-7410	127
1461	G331	-7425	257
1462	G329	-7440	127
1463	G327	-7455	257
1464	G325	-7470	127
1465	G323	-7485	257
1466	G321	-7500	127
1467	G319	-7515	257
1468	G317	-7530	127
1469	G315	-7545	257
1470	G313	-7560	127
1471	G311	-7575	257
1472	G309	-7590	127
1473	G307	-7605	257
1474	G305	-7620	127
1475	G303	-7635	257
1476	G301	-7650	127

PAD NO.	PAD Name	X	Y
1477	G299	-7665	257
1478	G297	-7680	127
1479	G295	-7695	257
1480	G293	-7710	127
1481	G291	-7725	257
1482	G289	-7740	127
1483	G287	-7755	257
1484	G285	-7770	127
1485	G283	-7785	257
1486	G281	-7800	127
1487	G279	-7815	257
1488	G277	-7830	127
1489	G275	-7845	257
1490	G273	-7860	127
1491	G271	-7875	257
1492	G269	-7890	127
1493	G267	-7905	257
1494	G265	-7920	127
1495	G263	-7935	257
1496	G261	-7950	127
1497	G259	-7965	257
1498	G257	-7980	127
1499	G255	-7995	257
1500	G253	-8010	127
1501	G251	-8025	257
1502	G249	-8040	127
1503	G247	-8055	257
1504	G245	-8070	127
1505	G243	-8085	257
1506	G241	-8100	127
1507	G239	-8115	257
1508	G237	-8130	127
1509	G235	-8145	257
1510	G233	-8160	127
1511	G231	-8175	257
1512	G229	-8190	127
1513	G227	-8205	257
1514	G225	-8220	127
1515	G223	-8235	257
1516	G221	-8250	127
1517	G219	-8265	257
1518	G217	-8280	127
1519	G215	-8295	257
1520	G213	-8310	127
1521	G211	-8325	257
1522	G209	-8340	127
1523	G207	-8355	257
1524	G205	-8370	127
1525	G203	-8385	257
1526	G201	-8400	127
1527	G199	-8415	257
1528	G197	-8430	127
1529	G195	-8445	257
1530	G193	-8460	127
1531	G191	-8475	257
1532	G189	-8490	127
1533	G187	-8505	257

PAD NO.	PAD Name	X	Y
1534	G185	-8520	127
1535	G183	-8535	257
1536	G181	-8550	127
1537	G179	-8565	257
1538	G177	-8580	127
1539	G175	-8595	257
1540	G173	-8610	127
1541	G171	-8625	257
1542	G169	-8640	127
1543	G167	-8655	257
1544	G165	-8670	127
1545	G163	-8685	257
1546	G161	-8700	127
1547	G159	-8715	257
1548	G157	-8730	127
1549	G155	-8745	257
1550	G153	-8760	127
1551	G151	-8775	257
1552	G149	-8790	127
1553	G147	-8805	257
1554	G145	-8820	127
1555	G143	-8835	257
1556	G141	-8850	127
1557	G139	-8865	257
1558	G137	-8880	127
1559	G135	-8895	257
1560	G133	-8910	127
1561	G131	-8925	257
1562	G129	-8940	127
1563	G127	-8955	257
1564	G125	-8970	127
1565	G123	-8985	257

PAD NO.	PAD Name	X	Y
1566	G121	-9000	127
1567	G119	-9015	257
1568	G117	-9030	127
1569	G115	-9045	257
1570	G113	-9060	127
1571	G111	-9075	257
1572	G109	-9090	127
1573	G107	-9105	257
1574	G105	-9120	127
1575	G103	-9135	257
1576	G101	-9150	127
1577	G99	-9165	257
1578	G97	-9180	127
1579	G95	-9195	257
1580	G93	-9210	127
1581	G91	-9225	257
1582	G89	-9240	127
1583	G87	-9255	257
1584	G85	-9270	127
1585	G83	-9285	257
1586	G81	-9300	127
1587	G79	-9315	257
1588	G77	-9330	127
1589	G75	-9345	257
1590	G73	-9360	127
1591	G71	-9375	257
1592	G69	-9390	127
1593	G67	-9405	257
1594	G65	-9420	127
1595	G63	-9435	257
1596	G61	-9450	127
1597	G59	-9465	257

PAD NO.	PAD Name	X	Y
1598	G57	-9480	127
1599	G55	-9495	257
1600	G53	-9510	127
1601	G51	-9525	257
1602	G49	-9540	127
1603	G47	-9555	257
1604	G45	-9570	127
1605	G43	-9585	257
1606	G41	-9600	127
1607	G39	-9615	257
1608	G37	-9630	127
1609	G35	-9645	257
1610	G33	-9660	127
1611	G31	-9675	257
1612	G29	-9690	127
1613	G27	-9705	257
1614	G25	-9720	127
1615	G23	-9735	257
1616	G21	-9750	127
1617	G19	-9765	257
1618	G17	-9780	127
1619	G15	-9795	257
1620	G13	-9810	127
1621	G11	-9825	257
1622	G9	-9840	127
1623	G7	-9855	257
1624	G5	-9870	127
1625	G3	-9885	257
1626	G1	-9900	127
1627	DUM5	-9930	257
1628	DUM6	-9945	127

15.5 Align Key Locations

--Alignment Mark coordinate

Left (-9963,-235)

Right (9963,-235)

--Alignment Mark size

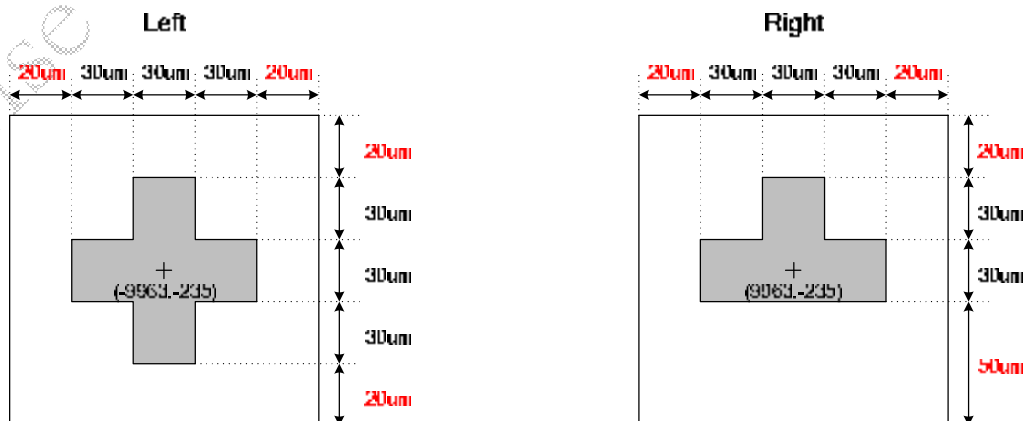

16. COG PRODUCTS MANUFACTURING GUIDELINES

16.1 Purpose:

The purpose of this specification is to identify ACF bonding process, so that customers can use properly ACF and Chip during the assembly.

16.2 Scope:

ACF bonding process

16.3 Noun definition

COG: Chip on Glass

ACF (Anisotropic Conductive Film): .ACF is a functional adhesive tape which is able to connect (**conductivity**, adhesion, insulation) multiterminals in one time

CTE: Coefficient of thermal expansion.

16.4 Responsibility unity:

ORISETECH Quality Assurance unity

16.5 Contents:

16.5.1 Applicable documents

IPC-SM-782: Surface Mount Design & Land Pattern Standard

IPC-7351 Generic Requirements for Surface Mount Design and Land Pattern Standard.

IPC JEDEC: J-STD-033A Standard for Handling, Packing, Shipping and Use of Moisture/Reflow Sensitive Surface Mount Devices

JESD22-B111: Board Level Drop Test of Components for Handheld Electronic Products

IPC-A-610: Acceptability of Electronic Assemblies

16.5.2 ACF Characteristics:

Three factors to achieve the connection: Temperature, Pressure, Time.

16.5.3 ACF process :

To use Low Temperature and Low stress ACF is recommended for thin chip as 300 um.

Warp issues may happen if customers do not use Low Temperature and Low stress ACF for long chip .And warp issues may induce chip broken after ACF bonding for the CTE mismatch of Glass and ACF and Chip.

To use 3um ACF is recommended for BUMP space is less than 13um.

To use Low temperature and long time bonding is recommended if delamination happens in edge of chip.

For fine pitch and thin chip (300 um) products, customer should review

ACF bonding condition with ACF maker.

16.6 References:

*IPC:

<http://www.ipc.org>

*HDPUG (High Density Package Users Group)

<http://www.hdpug.org>

*JEDEC (Joint Electronic Device Engineering Council)

<http://www.jedec.org>

*JEITA (Japan Electronic Industry Association)

<http://www.jeita.org>

17. DISCLAIMER

The information appearing in this publication is believed to be accurate.

Integrated circuits sold by ORISE Technology are covered by the warranty and patent indemnification provisions stipulated in the terms of sale only. ORISE Technology makes no warranty, express, statutory implied or by description regarding the information in this publication or regarding the freedom of the described chip(s) from patent infringement. FURTHERMORE, ORISE Technology MAKES NO WARRANTY OF MERCHANTABILITY OR FITNESS FOR ANY PURPOSE. ORISE Technology reserves the right to halt production or alter the specifications and prices at any time without notice. Accordingly, the reader is cautioned to verify that the data sheets and other information in this publication are current before placing orders. Products described herein are intended for use in normal commercial applications. Applications involving unusual environmental or reliability requirements, e.g. military equipment or medical life support equipment, are specifically not recommended without additional processing by ORISE Technology for such applications. Please note that application circuits illustrated in this document are for reference purposes only.

Orise Confidential for CPT use Only

18. REVISION HISTORY

Date	Revision #	Description	Page
SEP. 26, 2008	0.9	1. Correct the statement serial 8-bit data input through DG0~DG7 2. Correct R17/R18 VCOMH/VCOML value 3. Add DE set-up/hold time spec. in section 9.3 4. Add section 13 OTP program procedure	7 21 24 32
MAY. 15, 2008	0.8	1. Update section 4 BLOCK DIAGRAM 2. Add section 5 PIN ASSIGNMENT 3. Update 8.2 Register Summary and 8.3 4. Update section 9~11 5. Add section 14.4 Add Pad Locations.	5 6 12~22 33-42
MAY. 02, 2008	0.7	1. Correct coordinate of alignment marks (-9963,-235) and (9963,-235)	32
APR. 24, 2008	0.6	1. Correct some dimensions and right alignment mark on in figure of section 13.1 - adding input pad to chip edge: 58um - adding input pad length: 100um - correcting chip height: 730um - correcting distance between alignment mark and others - correcting outline dimension/shape of alignment mark 2. Correct outline dimension of alignment mark in section 13.5	31 32
APR. 17, 2008	0.5	1. revise description on features 2. Correct V5, V6, V7, V8 in the figure of section 6 3. Update remarks of section 6 4. Correct typo in 7.4.1 B6 5. Correct description of "TN_TYPE", "EXT_PWR" and "OTP_WEN" in section 5	4 9 9 13 6, 7, 8
APR. 16, 2008	0.4	1. Add section 11 Recommended Panel Routing Resistances 2. Add maximum LED no. of DCDC can control 3. Modify Bump Characteristic and Alignment Mark. 4. Add COG PRODUCTS MANUFACTURING GUIDELINES.	29 30 31-32 33
APR. 10, 2008	0.3	1. Update section 5 2. Update y of chip size	7, 8 30
APR. 01, 2008	0.2	1. Change default setting of SYNC pin and "SYNC" function register 2. Update section 6 3. Update section 12.2 4. Update section 12.5	6, 12, 18 9 30 31
MAR. 31, 2008	0.1	Original	33