



■ Description

The flash disk controller (OTi_6828) is a disk controller used to make a linear flash device array look like a normal disk, hiding the flash related problems with erasing.

The OTi_6828 is a controller with USB interface. The USB interface is for full speed operation (12Mb/s). It conforms to USB Specification, Version 1.1. The USB transceiver is embedded in this controller. With stable slew-rate control, the controller reduces EMI.

The OTi_6828 has a Phase Lock Loop (PLL) embedded. The PLL provides all clocks needed in this controller. It needs an externally provided clock operating in 14.318MHz.

The OTi_6828 has integrated the regulator for 5V input and 3.3V output. It also supports voltage detector for power on reset.

The OTi_6828 can control up to 4 pieces of NAND flash memory. The flash capacity can be 32M bits up to 1G bits. And these chips can be any combination. It has been optimized to support Toshiba and Samsung flash memory designs. It also supports Samsung's K9F and K9W Series flash. The controller has write-protected ability to prevent writing data to flash. The controller has a led control pin. It has three operation modes: suspend (off), active (fast) and idle (twinkle) mode. For read/write operation, the controller can achieve 1,000kB/920kB throughput. Comprehensive application with Windows OS is available.

This controller can operate in Win XP, Win2000, Windows Me, and Mac OS without any driver installation.

The OTi_6828 is available in cost-saving 32-pin TSOP package.

■ Features

- Flash controller with full-speed USB interface
- Integrated 5V/3.3V regulator, USB bus power supply capability
- USB Specification Compliance
 - Conforms to USB Specification, Version 1.1
- Integrated USB transceiver
 - Dynamic feedback control
 - Stable slew rate, independent of external loading
- RISC micro-controller
 - High-performance RISC architecture
 - Single cycle instruction execution
- 14.318 MHz external clock

- Integrated PLL
- Integrated Power On Reset (POR)
- Support up to 4 pieces of NAND Flash memory with write-protected ability
- Support Toshiba and Samsung's K9K series flash
- Support Samsung's K9F and K9W series flash
- Support wear-leveling
- Higher reliability: ECC on the fly
- Automatic bad block management
- Supported OS:
 - Win XP, Win2000, Windows ME, Linux 2.4 above, and MAC OS 9.0 & higher
 - Win 98/Win98SE driver available
 - Mac 8.6 mass storage driver available from Apple
 - Multiple LUN Windows driver is available
- LED indication:
 - Programmable through Mass Production Toolset
- Configurable Vendor ID/Product ID (VID/PID)
- Performance: Read (1,000kBytes/s) , Write (920kBytes/s) Max.
- Small form factor - standard 32-pin TSOP package



■ BLOCK DIAGRAM

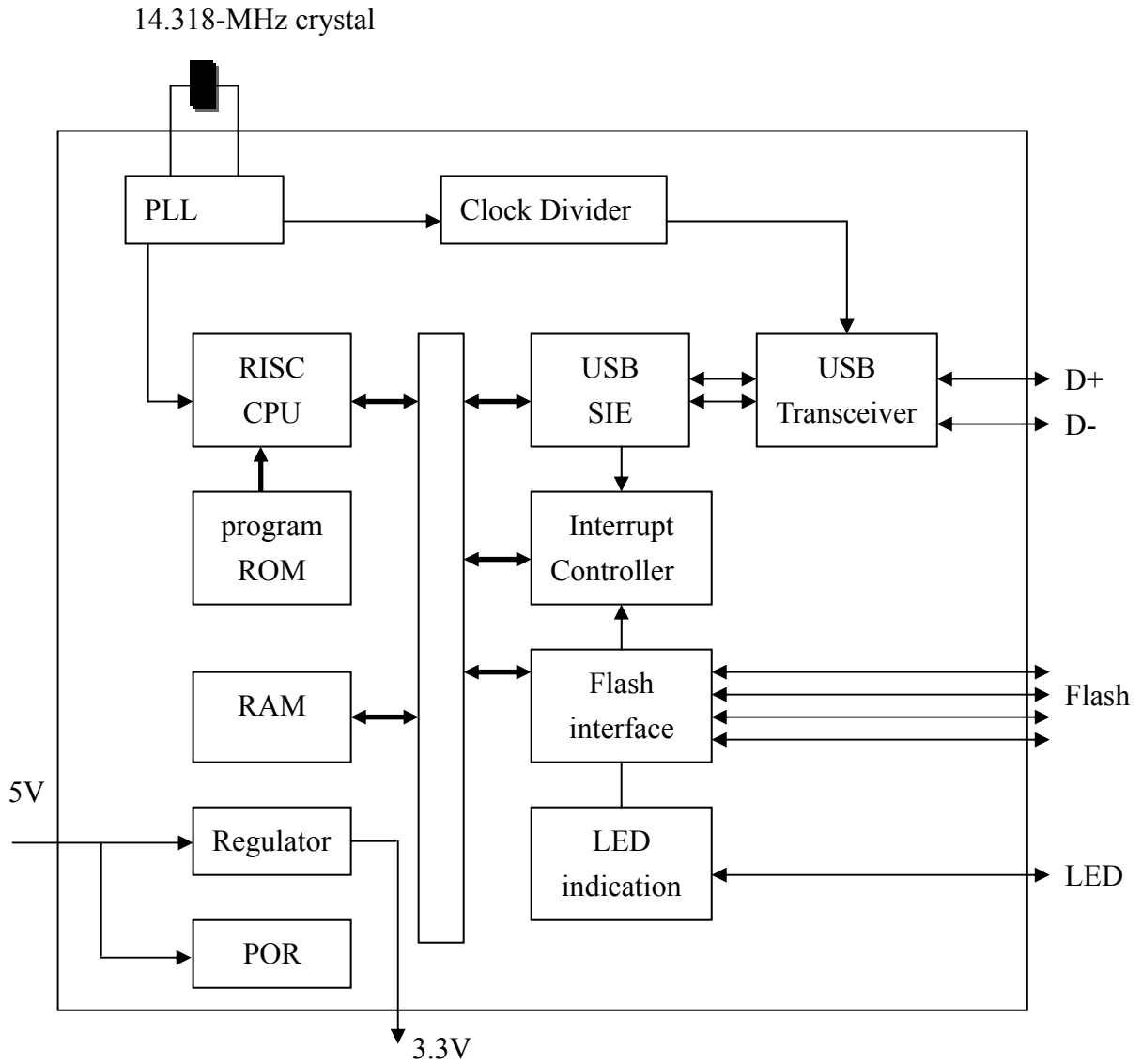

■ **Pin Configuration**

TSOP 32 L

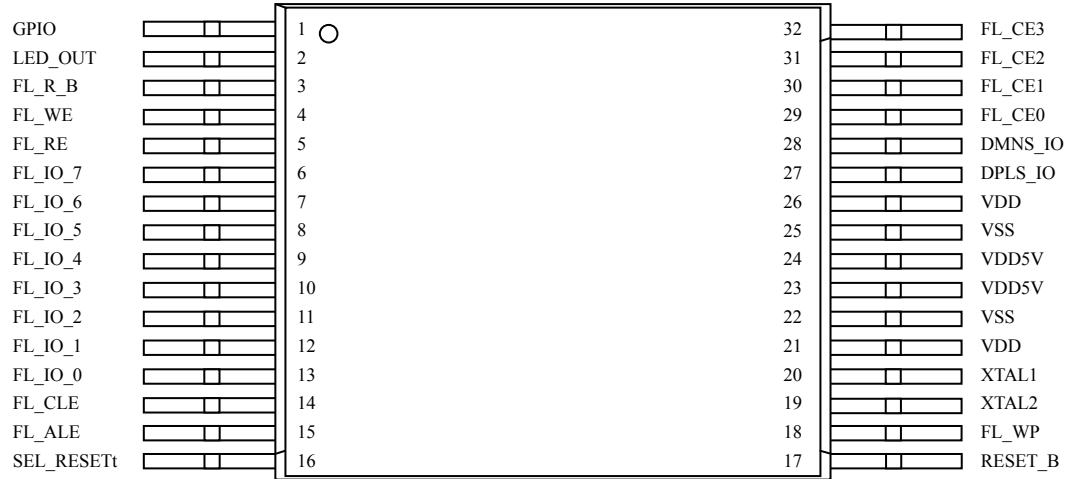



■ **Pin Description**

| Pin Name | Attribute | Description | Pin # |
|-----------|-----------|---|-------|
| GPIO | I/O | Reserved I/O | 1 |
| LED_OUT | O | LED indication(open drain) | 2 |
| FL_R_B | I | Flash Ready_Busy | 3 |
| FL_WE | O | Flash Write Enable | 4 |
| FL_RE | O | Flash Read Enable | 5 |
| FL_IO_7 | I/O | Flash data bus – bit 7 | 6 |
| FL_IO_6 | I/O | Flash data bus – bit 6 | 7 |
| FL_IO_5 | I/O | Flash data bus – bit 5 | 8 |
| FL_IO_4 | I/O | Flash data bus – bit 4 | 9 |
| FL_IO_3 | I/O | Flash data bus – bit 3 | 10 |
| FL_IO_2 | I/O | Flash data bus – bit 2 | 11 |
| FL_IO_1 | I/O | Flash data bus – bit 1 | 12 |
| FL_IO_0 | I/O | Flash data bus – bit 0 | 13 |
| FL_CLE | O | Flash Command Latch Enable | 14 |
| FL_ALE | O | Flash Address Latch Enable | 15 |
| SEL_RESET | I | Selection of Internal Reset or External Reset | 16 |
| RESET_B | I | Reset, active low | 17 |
| FL_WP | I/O | Flash Write Protect | 18 |
| XTAL2 | O | Crystal output | 19 |
| XTAL1 | I | Crystal input (14.318MHz) | 20 |
| VDD | P | 3.3V Output | 21 |
| VSS | P | GND | 22 |
| VDD5V | P | 5V Input | 23 |
| VDD5V | P | 5V Input | 24 |
| VSS | P | GND | 25 |
| VDD | P | 3.3V Output | 26 |
| DPLS_IO | I/O | USB D+ | 27 |
| DMNS_IO | I/O | USB D- | 28 |
| FL_CE0 | O | Flash Chip Enable – Chip 0 | 29 |

| | | | |
|--------|---|----------------------------|----|
| FL_CE1 | O | Flash Chip Enable – Chip 1 | 30 |
| FL_CE2 | O | Flash Chip Enable – Chip 2 | 31 |
| FL_CE3 | O | Flash Chip Enable – Chip 3 | 32 |

■ D.C. Characters

DC Characteristics-1 (Ta=0 °C to +70 °C, Vcc = 3.3V ±10%)

| Parameter | Symbol | MIN | TYP | MAX | Unit |
|----------------------------|--------|----------|-----|-----------|------|
| Power Supply | VDD5V | 4.5 | 5 | 5.5 | V |
| Input Voltage | VIH | 0.7x VDD | -- | 5 | V |
| | VIL | -0.3 | -- | 0.2 x VDD | V |
| Output Voltage | VOH | VDD-0.4 | -- | -- | V |
| | VOL | -- | -- | 0.4 | V |
| Input leakage current (*2) | ILK | -1 | -- | 1 | uA |
| Working Current | IRW | -- | 20 | -- | mA |
| Operating Temperature | Ta | 0 | | 70 | °C |
| Storage Temperature | Ts | -55 | | +150 | °C |
| IO output current | IOH | -- | 4 | -- | mA |
| | IOL | -- | 4 | -- | mA |

■ A.C. Characters

| Parameter | Symbol | MIN | TYP | MAX | Unit |
|----------------------|--------|------------|------------|------------|------|
| Input rising delay | TPIlh | 0.35(2PF) | 0.4(4PF) | 0.54(8PF) | ns |
| Input falling delay | TPIhl | 0.46(2PF) | 0.53(4PF) | 0.64(8PF) | ns |
| Output rising delay | TPOlh | 1.35(10PF) | 1.97(30PF) | 2.59(50pF) | ns |
| Output falling delay | TPOhl | 1.61(10PF) | 2.41(30PF) | 3.21(50pF) | ns |



Ours Technology Inc.

OTi-6828
FLASH DISK CONTROLLER

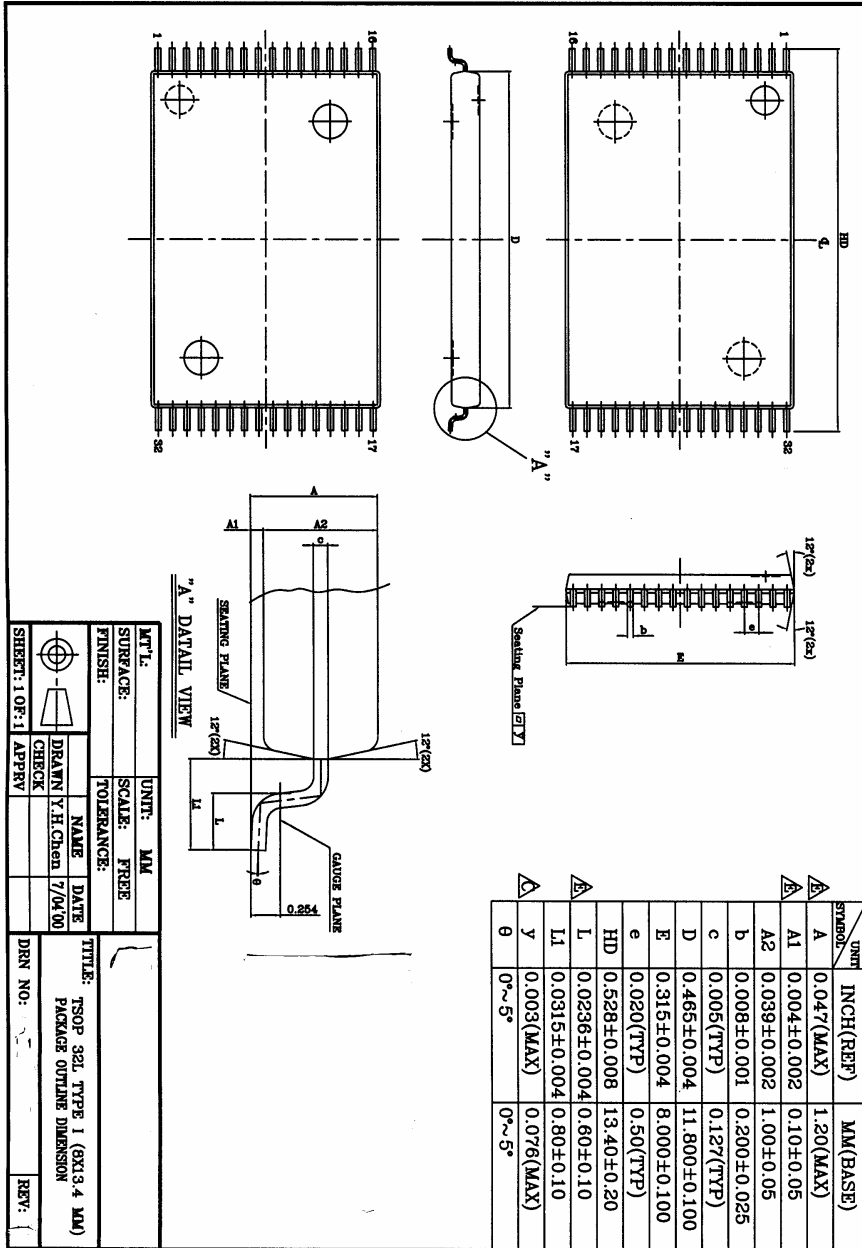

Note:

OTi reserves the right to make any changes without further notice to any products herein.

How to reach us:

OURS TECHNOLOGY INC. 4F, No. 85, Kung-Ming 6th Rd., Jubei City, Hsin-Chu Hsien, Taiwan, R.O.C.

TEL: +886-3-553-7511 FAX: +886-3-555-5804