

SPECIFICATION OF LCD MODULE

CUSTOMER 客户名称	
PART NO. 产品型号	OTM162G Y-YG-1
PRODUCTS TYPE 产品内容	
REMARKS 备注	
SIGNATURE BY CUSTOMER 客户签署:	

		
---	---	--

深圳市晶汉达电子有限公司

09年01月07日

LCM System

1 LCD Type

S - STN F - FSTN D - DFSTN

2 Viewing Angle

D - Lower 6:00 U - Upper 12:00 O - Others

3 Display Mode

Yellow Green positive Blue positive Grey positive
 FSTN positive W - FSTN negative

4 Polarizer Mode

Reflective Transflective Transmissive

5 Connector

Pin Heat sealed Normal

6 Thickness of Glass

1.1mm 0.4mm
 0.55mm 0.7mm

7 Backlight Mode:

LED CCFL

8 Backlight Color

Blue Amber Yellow Green
 Red White Without backlight

9 Temperature Grade

Normal temperature Wide temperature Super wide temperature

10 CG-ROM

01 for English + Japanese language

•REVISION RECORD

REV. NO.	REV. DATE	DESCRIPTION OF REVISION	PAGE	REMARK
1.0	07/01/09	INITIAL RELEASE	ALL	

CONTENTS

1.	FEATURES	5
2.	MECHANICAL SPEC	5
3.	ABSOLUTE MAXIMUM RATING	6
4.	ELECTRICAL CHARACTERISTICS	6
5.	ELECTRO-OPTICAL CHARACTERISTICS	8
6.	BLOCK DIAGRAM	9
7.	POWER SUPPLY	9
8.	TIMIING DIAGRAM	10
9.	AC CHARACTERISTICS.....	11
10.	INSTRUCTION SET	12
11.	INITIALIZATION SEQUENCE	13
12.	FONT TABLE.....	14
13.	EXTERNAL DIMENSION	15
14.	INTERFACE	16
15.	QC/QA PROCEDURE	17
16.	RELIABILITY	18
17.	HANDING PRECAUTIONS.....	19

1. FEATURES

•Display construction	16 Characters * 2 Lines
•Display mode	STN(Y/G)
•Display type	Positive Transflective
•Backlight	LED/5.0V(Y/G)
•Viewing direction	6 o'clock
•Operating temperature	-20 to 70 °C
•Storage temperature	-30 to 80 °C
•Controller	SPLC780D
•Driving voltage	Single power
•Driving method	1/16 duty, 1/5 bias
•Type	COB (Chip On Board)
•Number of data line	4/8-bit parallel
•Connector	PIN

2. MECHANICAL DATA

ITEM		WIDTH	HEIGHT	THICKNESS	UNIT
Module size		122.0	44.0	14.0(MAX)	mm
Viewing area		99.0	24.0	-	mm
character	Construction	5*7			dots
	Size	4.84	8.06	-	mm
	Pitch	6.00	10.34	-	mm
Dot	Size	0.92	1.10	-	mm
	Pitch	0.98	1.16	-	mm
Diameter of mounting hole		Φ3.5			mm
Weight		About 80			g

3. ABSOLUTE MAXIMUM RATINGS

(TA = 25 , Vss=0V)

Item	Symbol	MIN.	Max.	Unit
Supply Voltage (Logic)	VDD-VSS	0	7.0	V
Supply Voltage (LCD Driver)	V _{LCD}	VDD-12	VDD+0.3	V
Input Voltage	V _{IN}	-0.3	VDD+0.3	V
Operating temperature	Top	0	50	°C
Storage temperature	Tsto	-10	60	°C

4. ELECTRICAL CHARACTERISTICS

(VDD = 4.5 to 5.5V , TA = 25)

Characteristic	Symbol	Condition	Min	Typ	Max	Unit
Operating Voltage	V _{DD}	-	4.5	-	5.5	V
Operating Current	I _{DD}	Internal oscillation or external clock (V _{DD} = 5.0V, fosc = 270kHz)	-	0.35	0.6	mA
Input Voltage (1) (except OSC1)	V _{IH1}	-	2.2	-	V _{DD}	V
	V _{IL1}	-	-0.3	-	0.6	
Input Voltage (2) (OSC1)	V _{IH2}	-	V _{DD} -1.0	-	V _{DD}	V
	V _{IL2}	-	-0.2	-	1.0	
Output Voltage (1) (DB0 to DB7)	V _{OH1}	I _{OH} = -0.205mA	2.4	-	-	V
	V _{OL1}	I _{OL} = 1.2mA	-	-	0.4	
Output Voltage (2) (except DB0 to DB7)	V _{OH2}	I _O = -40μA	0.9V _{DD}	-	-	V
	V _{OL2}	I _O = 40μA	-	-	0.1V _{DD}	
Voltage Drop	V _{dCOM}	I _O = ±0.1mA	-	-	1	V
	V _{dSEG}		-	-	1	
Input Leakage Current	I _{LKG}	V _{IN} = 0V to V _{DD}	-1	-	1	μA
Input Low Current	I _{IL}	V _{IN} = 0V, V _{DD} = 5V (pull up)	-50	-125	-250	
Internal Clock (external Rf)	f _{OSC1}	Rf = 91kΩ ±2% (V _{DD} = 5V)	190	270	350	kHz
External Clock	f _{OSC}	-	125	270	350	kHz
	duty		45	50	55	%
	t _R , t _F		-	-	0.2	μA
LCD Driving Voltage	V _{LCD}	V _{DD} -V5 (1/5, 1/4 bias)	3.0	-	13.0	V

4.1 LED ELECTRICAL/OPTICAL CHARACTERISTICS

Item	Symbol	min	typ	max	Unit	Condition
Forward Voltage	V _f	4.8	5.0	5.2	V	I _f = 240 mA
Reverse Current	I _r	-	240	-	μA	V _r =10V
Dominant wave length	λ _d	565	570	575	nm	I _f = 240 mA
Spectral Line Half width	Δ λ	-	30	-	nm	I _f = 240 mA
Luminance	L _v	120	150	-	cd/m ²	I _f = 240 mA

4.2 LED ABSOLUTE MAXIMUM RATINGS

Item	Symbol	Condition	Rating	Unit
Reverse Voltage	V _r	T _a =25°C	10	V
Absolute maximum forward current	I _{fm}	T _a =25°C	480	mA
Power description	pd	T _a =25°C	2400	mW

4.2.1 LED ARRAY BLOCK DIAGRAM

(LED DICE 2×24= 48 dices)

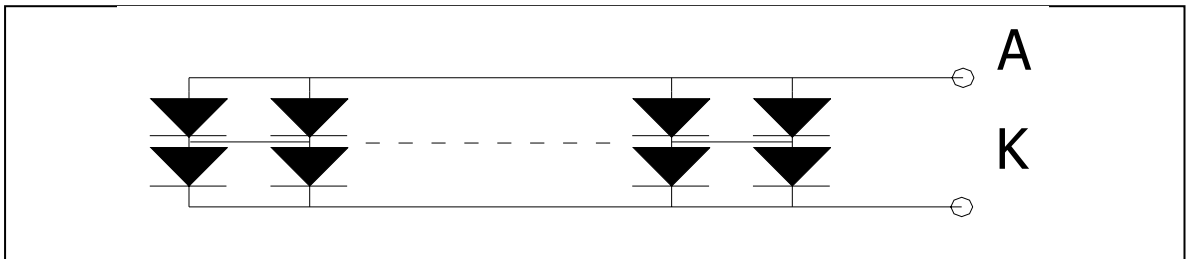

4.2.2 LED POWER SOURCE

LED	Option	Power source	Jumper setting
	A	15K/16A	J4 J5 R8
B	15A/16K	J3 J6 R7	

5. ELECTRO-OPTICAL CHARACTERISTICS

ITEM	SYMBOL	CONDITION	MIN.	TYP.	MAX.	UNIT	NOTE
Contrast ratio	K	$\phi=0$	1.4	4	-	-	1
Response time (rise)	Tr	$\phi=1$	-	130	-	ms	2
Response time (fall)	Tf	$\phi=2$		130	-	ms	2
Viewing angle	ϕ	K ≥ 1.4	10 -- +30			deg.	3
	θ		-30 -- +30				

Note 1: Definition of Contrast Ratio "K"

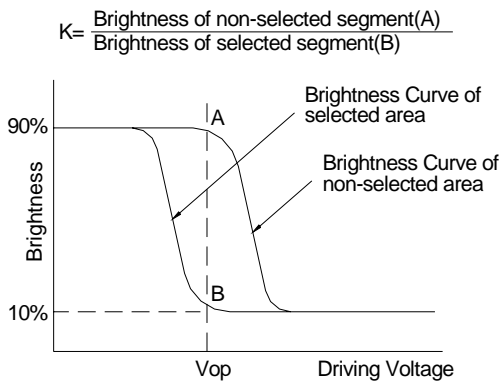

Note 2: Definition of Optical Response Time

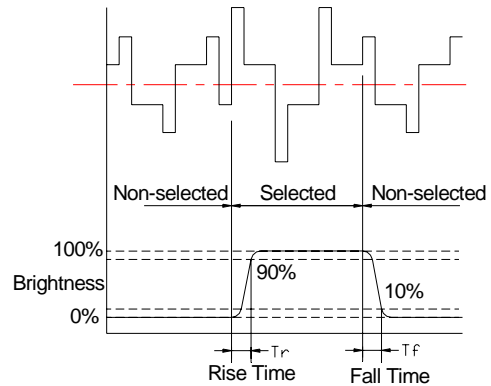

Note 3: Definition of Viewing Angle

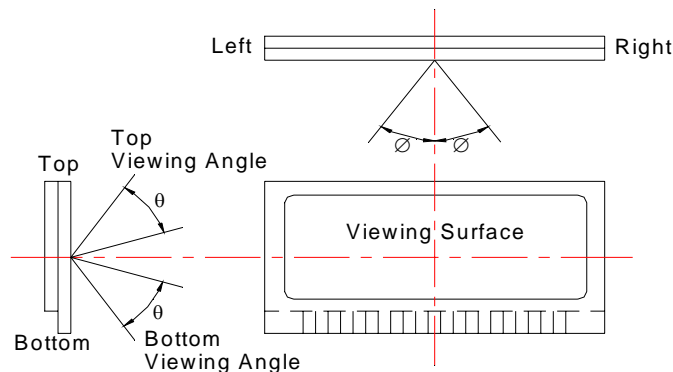

Please select either top or bottom viewing angle

6. BLOCK DIAGRAM

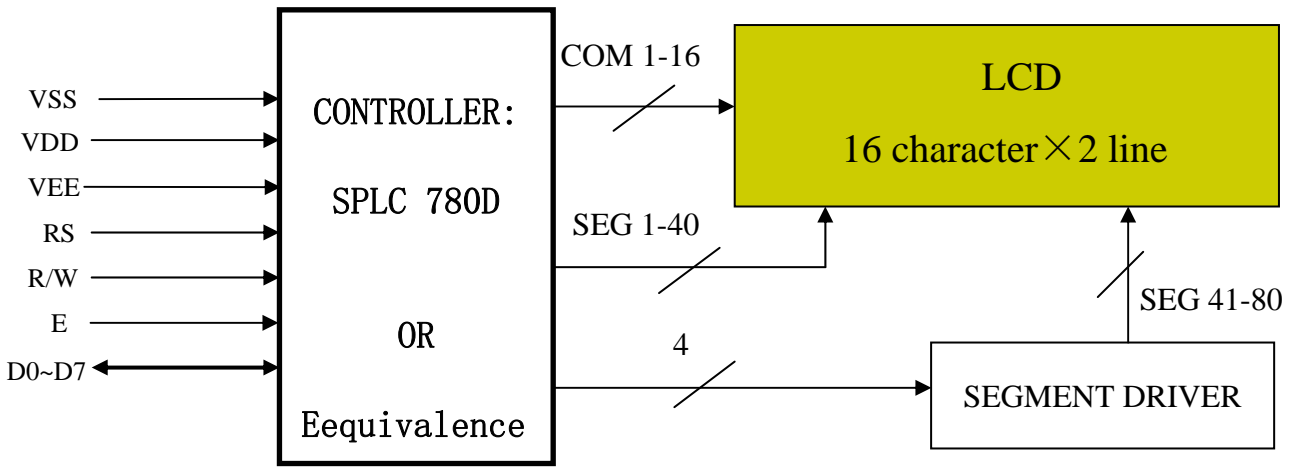

7. POWER SUPPLY

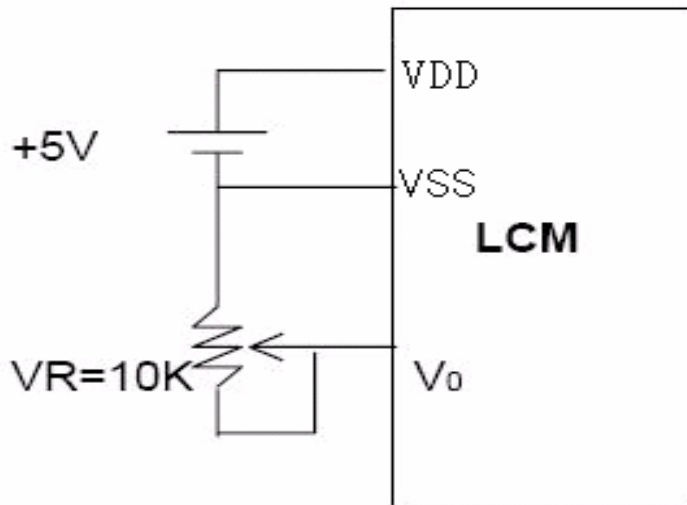

8. TIMING DIAGRAM

• WRITE OPERATION

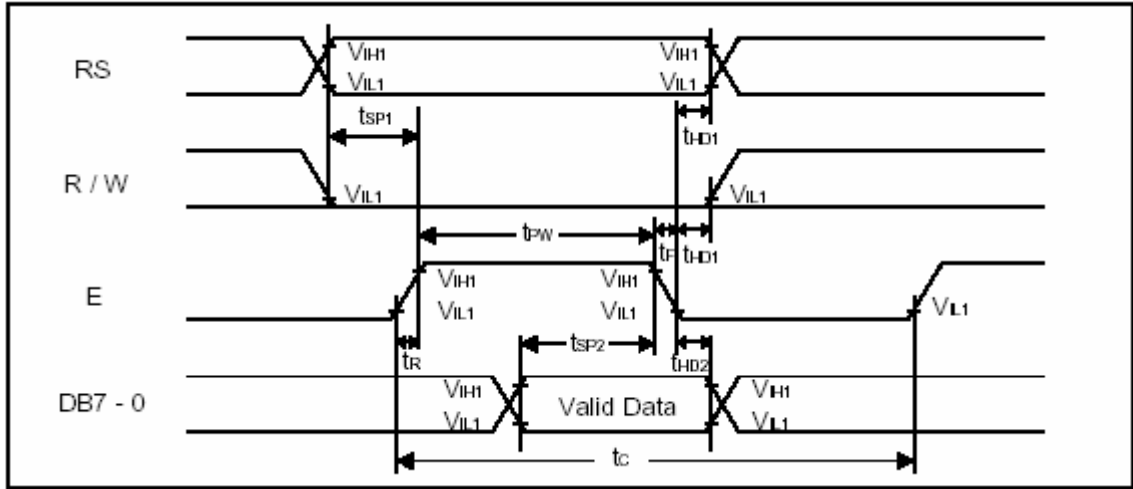

• READ OPERATION

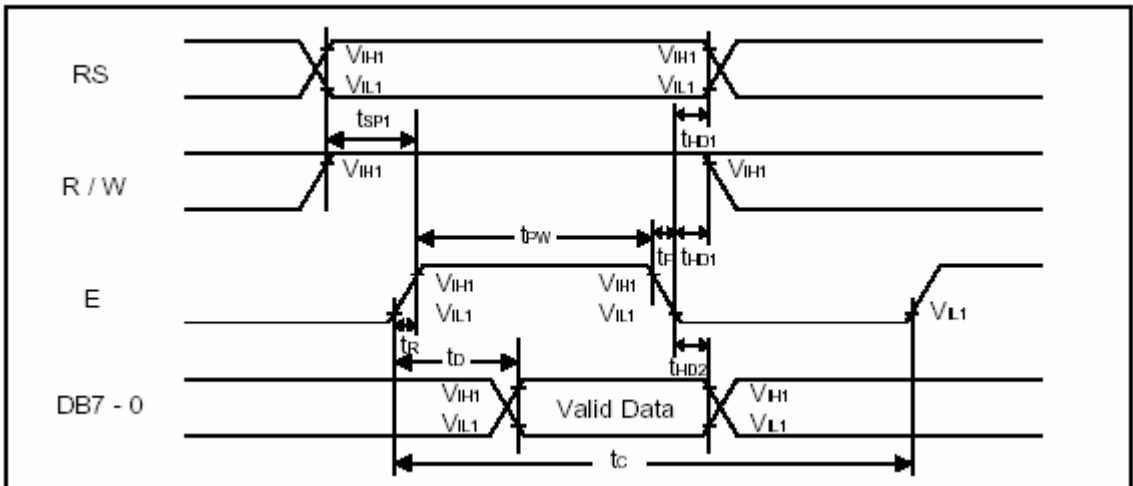

9. AC CHARACTERISTICS

• WRITE MODE

Characteristics	Symbol	Limit			Unit	Test Condition
		Min.	Typ.	Max.		
E Cycle Time	t_c	1000	-	-	ns	Pin E
E Pulse Width	t_{pw}	450	-	-	ns	Pin E
E Rise/Fall Time	t_r, t_f	-	-	25	ns	Pin E
Address Setup Time	t_{sp1}	60	-	-	ns	Pins: RS, R/W, E
Address Hold Time	t_{hd1}	20	-	-	ns	Pins: RS, R/W, E
Data Setup Time	t_{sp2}	195	-	-	ns	Pins: DB7 - 0
Data Hold Time	t_{hd2}	10	-	-	ns	Pins: DB7 - 0

• READ MODE

Characteristics	Symbol	Limit			Unit	Test Condition
		Min.	Typ.	Max.		
E Cycle Time	t_c	1000	-	-	ns	Pin E
E Pulse Width	t_w	450	-	-	ns	Pin E
E Rise/Fall Time	t_r, t_f	-	-	25	ns	Pin E
Address Setup Time	t_{sp1}	60	-	-	ns	Pins: RS, R/W, E
Address Hold Time	t_{hd1}	20	-	-	ns	Pins: RS, R/W, E
Data Output Delay Time	t_o	-	-	360	ns	Pins: DB7 - 0
Data hold time	t_{hd2}	5.0	-	-	ns	Pin DB7 - 0

10. INITIALIZATION SEQUENCE

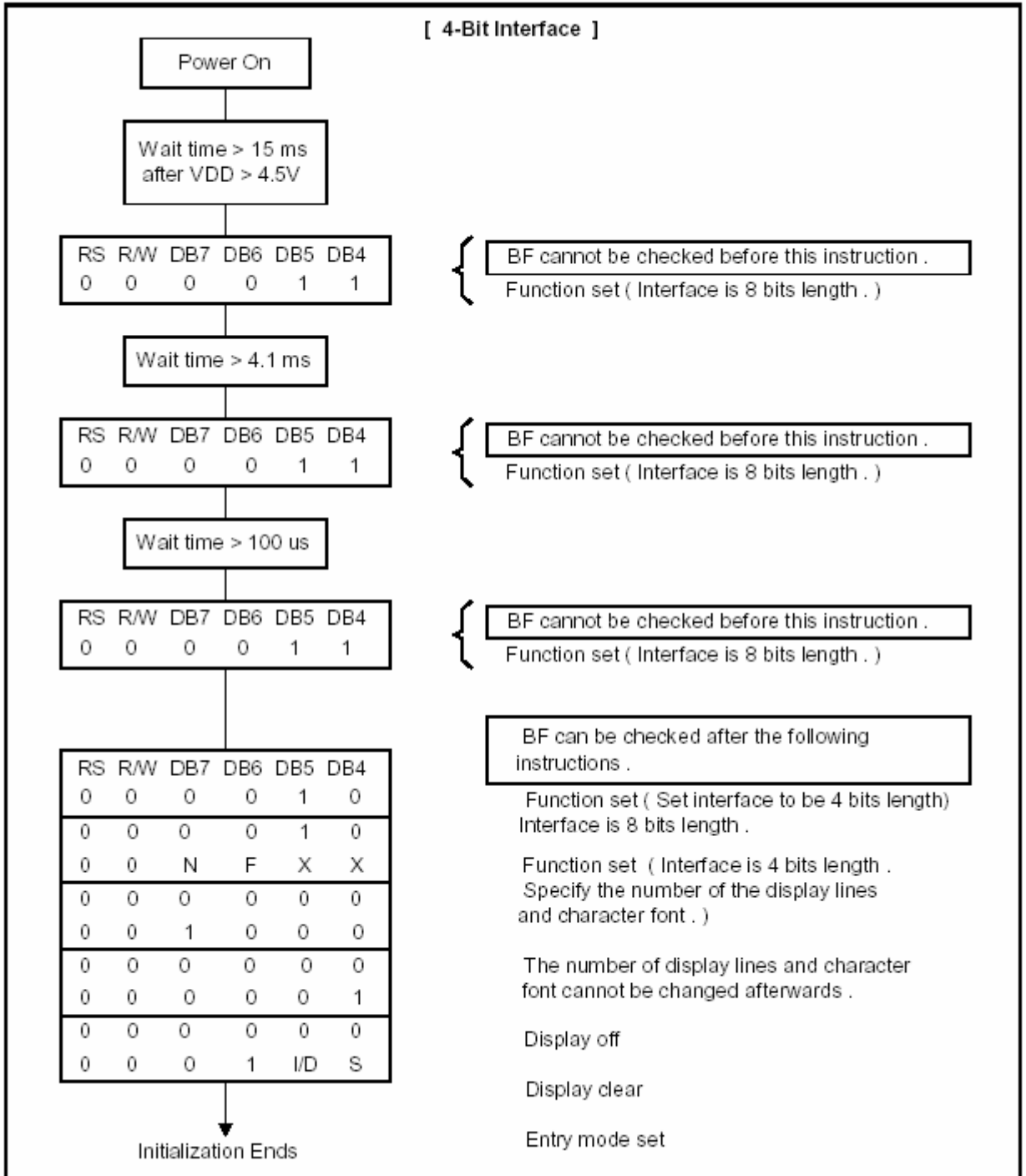

11. INSTRUCTION SET

COMMAND	COMMAND CODE										COMMAND CODE	E-CYCLE $f_{osc}=250\text{KHz}$	
	RS	R/W	DB7	DB6	DB5	DB4	DB3	DB2	DB1	DB0			
SCREEN CLEAR	0	0	0	0	0	0	0	0	0	1	Screen Clear, Set AC to 0 Cursor Reposition	1.64ms	
CURSOR RETURN	0	0	0	0	0	0	0	0	0	1	*	DDRAM AD=0, Return, Content Changeless	1.64ms
INPUT SET	0	0	0	0	0	0	0	0	1	I/D	S	Set moving direction of cursor, Appoint if move	40us
DISPLAY SWITCH	0	0	0	0	0	0	0	1	D	C	B	Set display on/off,cursor on/off, blink on/off	40us
SHIFT	0	0	0	0	0	0	1	S/C	R/L	*	*	Remove cursor and whole display,DDRAM changeless	40us
FUNCTION SET	0	0	0	0	0	1	DL	N	F	*	*	Set DL,display line,font	40us
CGRAM AD SET	0	0	0	1	ACG						Set CGRAM AD, send receive data	40us	
DDRAM AD SET	0	0	1	ADD						Set DDRAM AD, send receive data	40us		
BUSY/AD READ CT	0	1	BF	AC						Executing internal function, reading AD of CT	40us		
CGRAM/ DDRAM DATA WRITE	1	0	DATA WRITE						Write data from CGRAM or DDRAM	40us			
CGRAM/ DDRAM DATA READ	1	1	DATA READ						Read data from CGRAM or DDRAM	40us			
	I/D=1: Increment Mode; I/D=0: Decrement Mode S=1: Shift S/C=1: Display Shift; S/C=0: Cursor Shift R/L=1: Right Shift; R/L=0: Left Shift DL=1: 8D DL=0: 4D N=1: 2R N=0: 1R F=1: 5x10 Style; F=0: 5x7 Style BF=1: Execute Internal Function; BF=0: Command Received										DDRAM: Display data RAM CGRAM: Character Generator RAM ACG: CGRAM AD ADD: DDRAM AD & Cursor AD AC: Address counter for DDRAM & CGRAM	E-cycle changing with main frequency. Example: If fcp or $f_{osc}=270\text{KHz}$ 40us x 250/270 =37us	

12. FONT TABLE

b7- b3 b4 -b0	0000	0010	0011	0100	0101	0110	0111	1010	1011	1100	1101	1110	1111
0000	CG RAM (1)	ø	a	P	`	P	—	9	ε	ø	p		
0001	(2)	!	1	A	Q	a	9	u	7	7	ε	ä	q
0010	(3)	"	2	B	R	b	r	Γ	イ	ウ	×	ß	θ
0011	(4)	#	3	C	S	c	s	┘	ウ	テ	ε	ε	ω
0100	(5)	\$	4	D	T	d	t	、	Ⅰ	ト	ト	μ	Ω
0101	(6)	%	5	E	U	e	u	・	オ	ナ	┘	ε	Ü
0110	(7)	&	6	F	V	f	v	ヲ	カ	ニ	ヨ	ρ	Σ
0111	CG RAM (8)	'	7	G	W	g	w	7	7	ヌ	ウ	g	π
1000	CG RAM (1)	<	B	H	X	h	x	イ	ウ	ホ	リ	μ	×
1001	(2))	9	I	Y	i	y	ウ	ケ	リ	ル	'	y
1010	(3)	*	:	J	Z	j	z	エ	コ	ン	ル	j	7
1011	(4)	+	:	K	[k	[オ	サ	ヒ	ロ	*	κ
1100	(5)	,	<	L	¥	l	l	カ	シ	フ	ウ	φ	κ
1101	(6)	—	=	M	l	m)	ユ	ヌ	、	ン	ε	÷
1110	(7)	,	>	N	^	n	→	ヨ	セ	ホ	、	κ	
1111	CG RAM (8)	/	?	O	_	o	←	ッ	リ	マ	°	ö	

13. EXTERNAL DIMENSION

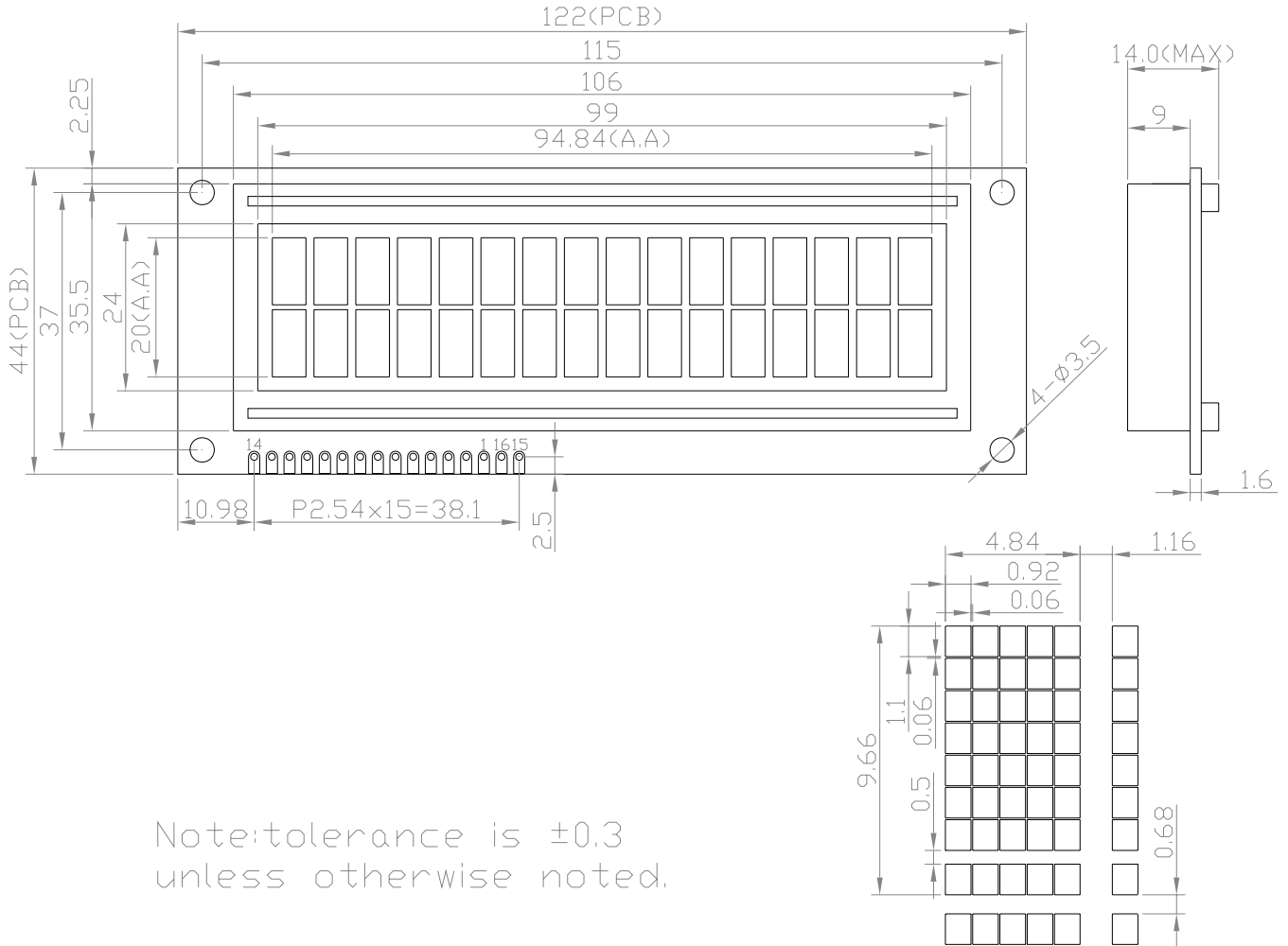

1	2	3	4	5	6	7	8
VSS	VDD	V0	RS	R/W	E	DB0	DB1
9	10	11	12	13	14	15	16
DB2	DB3	DB4	DB5	DB6	DB7	LEDK	LEDA

14. INTERFACE

PIN NO.	SYMBOL	DESCRIPTION	FUNCTION
1	VSS	GROUND	0V (GND)
2	VDD	POWER SUPPLY FOR LOGIC CIRCUIT	+5V
3	V0	LCD CONTRAST ADJUSTMENT	
4	RS	INSTRUCTION/DATA REGISTER SELECTION	RS = 0 : INSTRUCTION REGISTER RS = 1 : DATA REGISTER
5	R/W	READ/WRITE SELECTION	R/W = 0 : REGISTER WRITE R/W = 1 : REGISTER READ
6	E	ENABLE SIGNAL	
7	DB0	DATA INPUT/OUTPUT LINES	8 BIT: DB0-DB7
8	DB1		
9	DB2		
10	DB3		
11	DB4		
12	DB5		
13	DB6		
14	DB7		
15	LEDK	SUPPLY VOLTAGE FOR LED+	0V
16	LEDA	SUPPLY VOLTAGE FOR LED-	+5V

15. QC/QA PROCEDURE

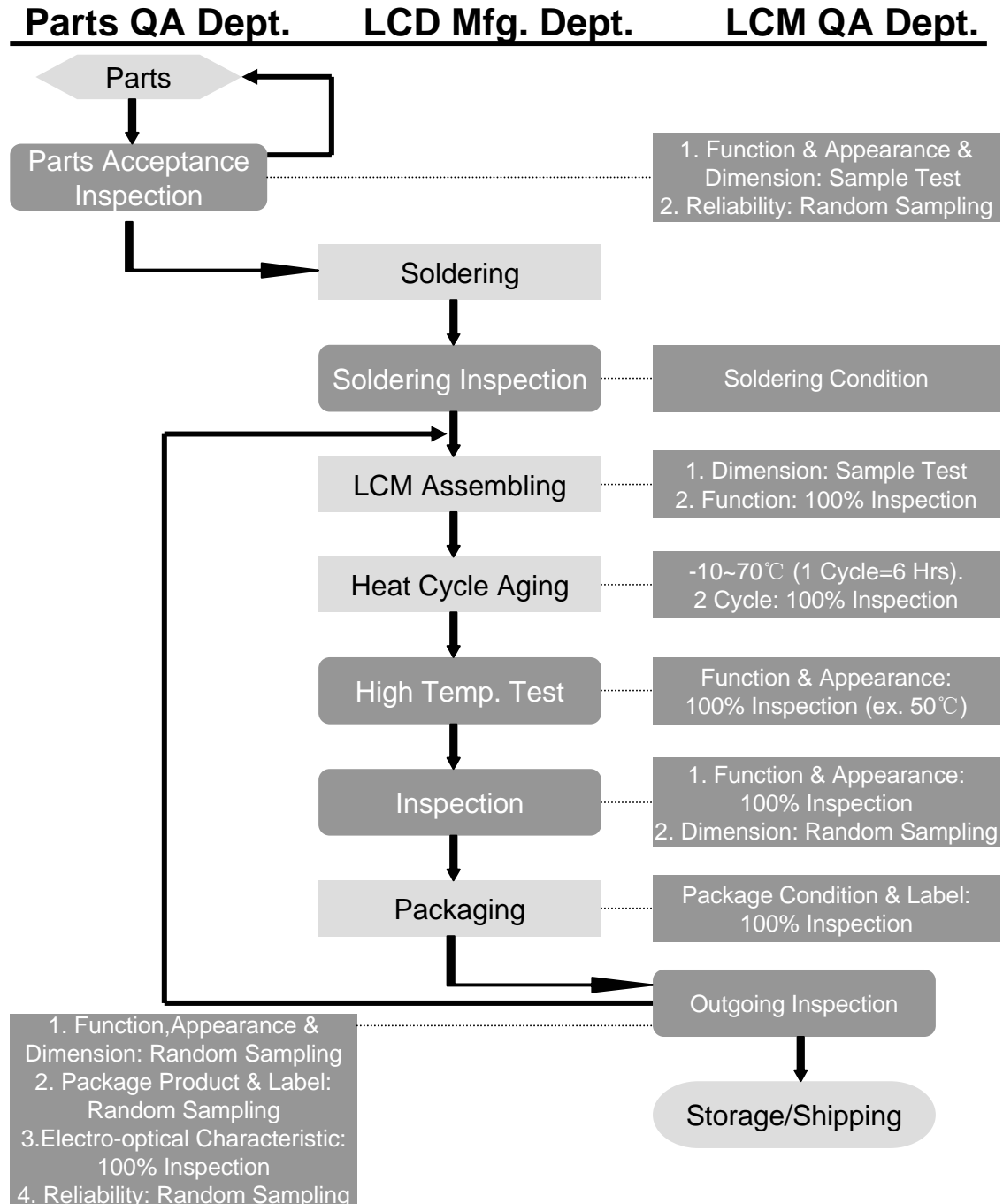

13. QUALITY ASSURANCE

13.1.1 Temperature and Humidity(Ambient Temperature)

Temperature : $20 \pm 5^{\circ} \text{C}$

Humidity : $65 \pm 5\%$

13.1.2 Operation

Unless specified otherwise, test will be conducted under function state.

13.1.3 Container

Unless specified otherwise, vibration test will be conducted to the product itself without putting it in a container.

13.1.4 Test Frequency

In case of related to deterioration such as shock test.It will be conducted only once.

13.1.5 Test Method

No.	Parameter	Conditions	Regulations
1	High Temperature Operating	$70 \pm 2^{\circ}\text{C}$	Note 3
2	Low Temperature Operating	$-20 \pm 2^{\circ}\text{C}$	Note 3
3	High Temperature Storage	$80 \pm 2^{\circ}\text{C}$	Note 3
4	Low Temperature Storage	$-30 \pm 2^{\circ}\text{C}$	Note 3
5	Vibration Test (Non-operation state)	Total fixed amplitude : 1.5mm Vibration Frequency : 10 ~ 55Hz One cycle 60 seconds to 3 directions of X.Y.Z. for each 15 minutes	Note 3
6	Damp Proof Test (Non-operation state)	$40^{\circ}\text{C} \pm 2^{\circ}\text{C}$, 90~95%RH, 96h	Note 1,2
7	Shock Test (Non-operation state)	To be measured after dropping from 60cm high once concrete surface in packing state	Note 3

Note 1: Returned under normal temperature and humidity for 4 hrs.

Note 2: No dew condensation to be observed.

Note 3: No change on display and in operation under the test condition

17. Handling Precautions

1. Limitation of Application:

Optrex products are designed for use in ordinary electronic devices such as business machines, telecommunications equipment, measurement devices and etc. Please handle the products with care. (see below)

Optrex products are not designed, intended, or authorized for use in any application which the failure of the product could result in a situation where personal injury or death may occur. these applications include, but are not limited to, life-sustaining equipment, nuclear control devices, aerospace equipment, devices related to hazardous or flammable materials, etc. [If Buyer intends to purchase or use the Optrex Products for such unintended or unauthorized applications, Buyer must secure prior written consent to such use by a responsible officer of Optrex Corporation.] Should Buyer purchase or use Optrex Products for any such unintended or unauthorized application [without such consent]. Buyer shall indemnify and hold Optrex and its officers, employees, subsidiaries, affiliates and distributors harmless against all claims, costs, damages and expenses, and reasonable attorney's fees, arising out of, directly or indirectly, any claim of personal injury or death associated with such unintended or unauthorized use, even if such claim alleges that Optrex was negligent regarding the design or manufacture of the part.

2. Industrial Rights and Patents

Optrex shall not be responsible for any infringement of industrial property rights of third parties in any country arising out of the application or use of Optrex products, except which directly concern the structure or production of such products.

No Press and Shock!

If pressure to LCD, orientation may be disturbed. LCD will broken by shock!

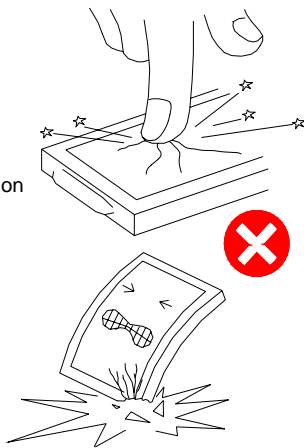

Don't Swallow or Touch Liquid Crystal!

Liquid Crystal may be leaked when display is broked. If it accidentally gets your hands, wash then with water!

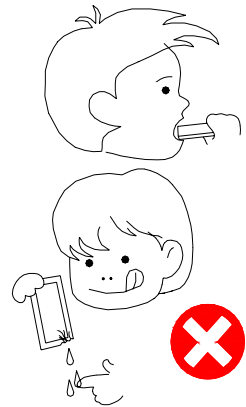

Don't not Scratch!

Polarizer is a soft material and can easily be scratched.

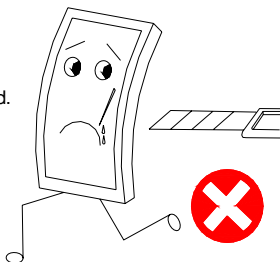

No DC Voltage to LCD!

DC vorage or driving higher than the specified voltage will reduce the lifetime of the LCD.

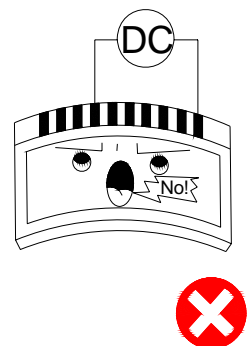

Don't Press the Metallic Frame and Disassemble the LCM

Pressure on the metallic frame and PCB may deform the conductive rubber or break the liquid crystal cell and back light, which will cause defects.

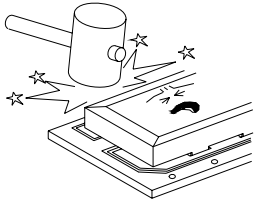

LCD may be shifted or conductive rubber may be reshaped, which will cause defects.

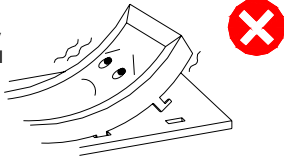

Slowly Peel Off Protective Film!

Avoid static electricity.

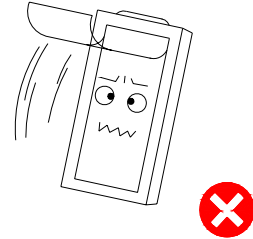

Avoid Static Electricity!

Please be sure to ground human body and electric appliances during work. It is preferable to use conductive mat on table and wear cotton clothes or conduction processed fiber. Synthetic fiber is not recommended.

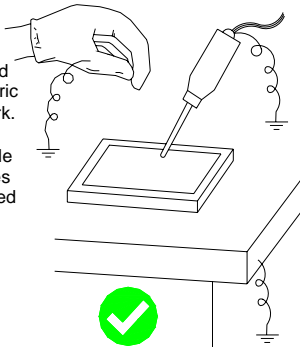

Wear Gloves While Handling!

It is preferable to wear gloves to avoid damaging the LCD.

Please do not touch electrodes with bare hands or make them dirty.

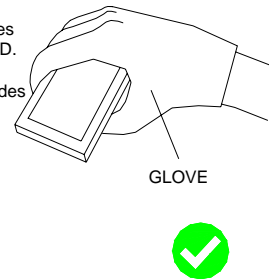

Keep Away From Extreme Heat and Humidity!

LCD deteriorates.

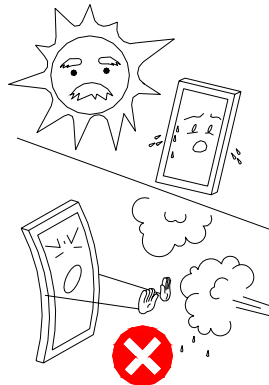

Use Alcohol to Clean Terminals!

When attaching with the heat seal or anisotropically conductive film, wipe off with alcohol before use.

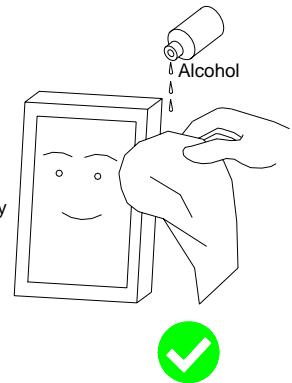

Don't Drop Water on LCD!

Note that the presence of waterdrops or dew in the LCD panel may deteriorate the polarizer or corrode electrode.

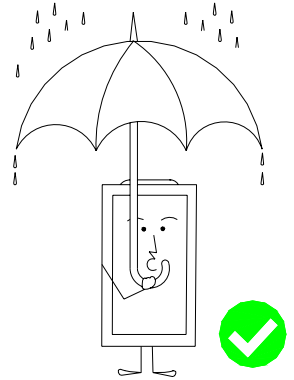
**Precaution in Soldering LCD Module**

Basic instructions: Solder I/O terminals only.
Use soldering iron without leakage.

(1) Soldering condition to I/O terminals

Temperature at tip of the iron: $280 \pm 10^{\circ}\text{C}$

Soldering time: 3~4 sec.

Type of solder: Eutectic solder (containing colophony-flux)

*Please do not use flux because it may soak into LCD Module or contaminate it.

*It is preferable to peel off protective film on display surface after soldering I/O terminals is finished.

(2) Remove connector or cable

*When you remove connector or cable soldered to I/O terminals, please confirm that solder is fully melted. If you remove by force, electrodes at I/O terminals may be damaged (or stripped off).

*It is recommended to use solder suction machine.

Long-term Storage

If it is necessary to store LCD modules for a long time, please comply with the following procedures.

If storage condition is not satisfactory, display (especially polarizer) may be deteriorated or soldering I/O terminals may become difficult (some oxide is generated at I/O terminals plating).

1. Store as delivered by Optrex

2. If you store as unpacked, put in anti-static bag, seal its opening and store where it is not subjected to direct sunshine nor fluorescent lamp.

3. Store at temperature 0 to $+35^{\circ}\text{C}$ and at low humidity. Please refer to our specification sheets for storage temperature range and humidity condition.

Long-term Storage

Please use power supply with built-in surge protection circuit.