

SPECIFICATION OF LCD MODULE

CUSTOMER 客户名称	
PART NO. 产品型号	OTM804 Y-YG-1
PRODUCTS TYPE 产品内容	
REMARKS 备注	12864IYY-L1-V1.0
SIGNATURE BY CUSTOMER 客户签署:	

		
---	---	--

深圳市真石贸易有限公司

08年1月18日

LCM System

1 LCD Type

S - STN
 F - FSTN
 D - DFSTN

2 Viewing Angle

D - Lower 6:00
 U - Upper 12:00
 O - Others

3 Display Mode

Yellow Green positive
 Blue Negative
 Grey positive
 FSTN positive
 W - FSTN negative

4 Polarizer Mode

Reflective
 Transflective
 Transmissive

5 Connector

Pin
 Heat sealed
 Zebra

6 Thickness of Glass

1.1mm
 0.4mm
 0.55mm
 0.7mm

7 Backlight Mode:

LED
 CCFL

8 Backlight Color

Blue
 Amber
 Yellow Green
 Red
 White
 Without backlight

9 Temperature Grade

Normal temperature
 Wide temperature
 Super wide temperature

•REVISION RECORD

REV. NO.	REV. DATE	DESCRIPTION OF REVISION	PAGE	REMARK
1.0	01/03/08	INITIAL RELEASE	ALL	

Free datasheet http://www.datasheet4u.com/

CONTENTS

1.	FEATURES	5
2.	MECHANICAL SPEC	5
3.	ABSOLUTE MAXIMUM RATING	6
4.	ELECTRICAL CHARACTERISTICS	8
5.	ELECTRO-OPTICAL CHARACTERISTICS	10
6.	BLOCK DIAGRAM	11
7.	POWER SUPPLY	11
8.	TIMIING DIAGRAM	12
9.	INSTRUCTION SET	14
10.	INITIALIZATION SEQUENCE	15
11.	EXTERNAL DIMENSION	16
12.	INTERFACE	17
13.	PACKAGE INFORMATION.....	18
14.	QC/QA PROCEDURE	19
15.	RELIABILITY	20
16.	INSPECTION CONDITION	21
17.	HANDING PRECAUTIONS.....	24
18.	STANDARD LCD MODULE NUMBERING SYSTEM	27

1. FEATURES

- Display construction..... 128*64 DOTS
- Display mode..... STN(Y/G)
- Display type..... Positive Transmissive
- Backlight..... LED/4.2V(Y/G)
- Viewing direction..... 6 o'clock
- Operating temperature..... -20 to 70 °C
- Storage temperature -30 to 80 °C
- Driving voltage..... Single power
- Driving method..... 1/32 duty, 1/5 bias
- Type..... COB (Chip On Board)
- Controller/Drive IC..... KS0107/KS0108
- Number of data line..... 8-bit parallel
- Connector..... Pin

2. MECHANICAL DATA

ITEM	WIDTH	HEIGHT	THICKNESS	UNIT
Module size	75.0	52.8	9.5(MAX)	mm
Viewing area	60.0	32.5	-	mm
Dot	Size	0.4	0.4	mm
	Pitch	0.43	0.43	mm
Diameter of mounting hole	Φ 2.5			mm
Weight	About 50			g

3. ABSOLUTE MAXIMUM RATINGS

3.1 Electrical Absolute Maximum Rating

Characteristic	Symbol	Value	Unit	Note
Operating voltage	V_{DD}	-0.3 to +7.0	V	
Supply voltage	V_{EE}	$V_{DD}-19.0$ to $V_{DD}+0.3$	V	
Driver supply voltage	V_B	-0.3 to $V_{DD}+0.3$	V	
	V_{LCD}	$V_{EE}-0.3$ to $V_{DD}+0.3$	V	
Operating temperature	T_{OPR}	-20 to 70	°C	
Storage temperature	T_{STG}	-30 to 80	°C	

3.2 Environmental Absolute Maximum Rating

Item	Operating		Storage		Comment
	Min.	Max.	Min.	Max.	
Ambient temp	-20	+70	-30	+80	Note(1)
Humidity	Note(2)		Note(2)		Without condensation
Vibration	--	4.9M/S ²	--	19.6M/S ²	XYZ direction
Shock	--	29.4M/S ²	--	490M/S ²	XYX direction

Note(1) $T_a=0^{\circ}\text{C}$: 50 Hr Max.

Note(2) $T_a \leq 40^{\circ}\text{C}$: 90%RH Max.

$T_a \geq 40^{\circ}\text{C}$: Absolute humidity must be lower than the humidity of 90%RH@40°C

3.3 Electronic Static Discharge Maximum Rating

ESD Test Method : IEC-1000-4-2

Item	Description	
Testing environment	Ambient temperature : to Humidity : 30% to 60% LCM(E.U.T) : Power up	
Testing equipment	Manufacture : Noiseken, Model No. ESD	
Testing condition	See drawing 1	
Direct discharge	0 to \pm 4KV	Discharge point, see drawing2
Indirect discharge	0 to \pm 8KV	Discharge point, see drawing1
Pass condition	No malfunction of unit. Temporary malfunction of unit which can be recovered by system reset.	
Fail condition	Non. Recoverable malfunction of LCM or system.	

FIG1 ESD Testing Equipment

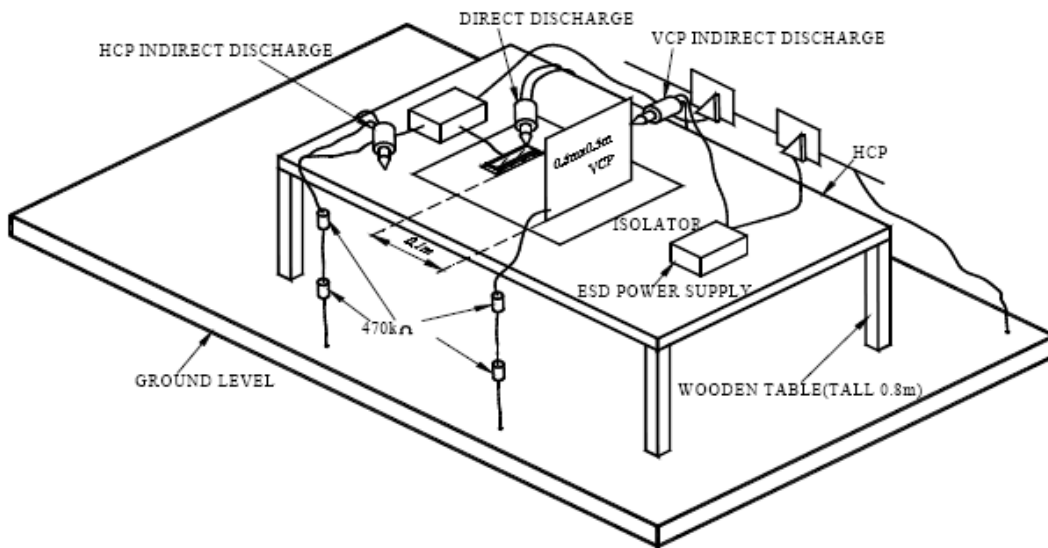

Direct Contact Discharge / Contact Point : A,B,C,D

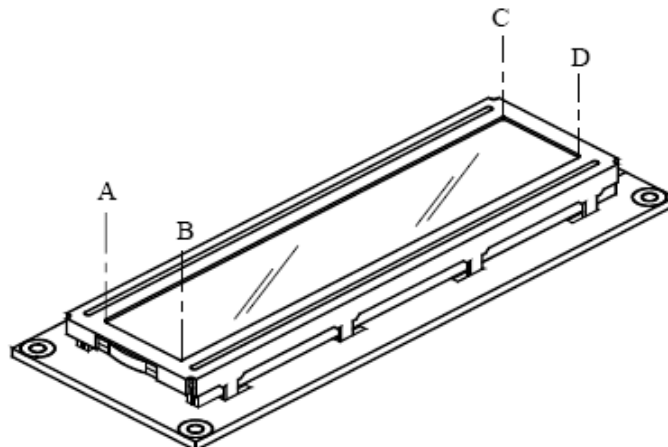

4. ELECTRICAL CHARACTERISTICS

($V_{DD} = +5V \pm 10\%$, $V_{SS} = 0V$, $V_{DD}-V_{EE} = 8$ to $17V$, $T_a = -20$ to 70 °C)

Characteristic	Symbol	Condition	Min	Typ	Max	Unit	Note
Input high voltage	V_{IH1}	–	$0.7V_{DD}$	–	V_{DD}	V	(1)
	V_{IH2}	–	2.0	–	V_{DD}	V	(2)
Input low voltage	V_{IL1}	–	0	–	$0.3V_{DD}$	V	(1)
	V_{IL2}	–	0	–	0.8	V	(2)
Output high voltage	V_{OH}	$I_{OH} = -200\mu A$	2.4	–	–	V	(3)
Output low voltage	V_{OL}	$I_{OL} = 1.6mA$	–	–	0.4	V	(3)
Input leakage current	I_{LKG}	$V_{IN} = V_{SS} - V_{DD}$	-1.0	–	1.0	μA	(4)
Three-state(off) input current	I_{TSL}	$V_{IN} = V_{SS} - V_{DD}$	-5.0	–	5.0	μA	(5)
Driver input leakage current	I_{DIL}	$V_{IN} = V_{EE} - V_{DD}$	-2.0	–	2.0	μA	(6)
Operating current	I_{DD1}	During display	–	–	100	μA	(7)
	I_{DD2}	During access Access cycle = 1MHz	–	–	500	μA	(7)
On resistance	R_{ON}	$V_{DD}-V_{EE} = 15V$ $I_{LOAD} = \pm 0.1mA$	–	–	7.5	$K\Omega$	(8)

NOTES:

- CL, FRM, M, RSTB, CLK1, CLK2
- CS1B, CS2B, CS3, E, R/W, RS, DB0 - DB7
- DB0 - DB7
- Except DB0 - DB7
- DB0 - DB7 at high impedance
- $V_{OL}(R)$, $V_{2L}(R)$, $V_{3L}(R)$, $V_{5L}(R)$
- 1/64 duty, FCLK = 250kHz, frame frequency = 70HZ, output: no load
- $V_{DD} - V_{EE} = 15.5V$
 $V_{OL}(R) > V_{2L}(R) = V_{DD} - 2/7 (V_{DD}-V_{EE}) > V_{3L}(R) = V_{EE} + 2/7 (V_{DD}-V_{EE}) > V_{5L}(R)$

4.1 LED ELECTRICAL/OPTICAL CHARACTERISTICS

Item	Symbol	min	typ	max	Unit	Condition
Forward Voltage	V _f	4.0	4.2	4.4	V	I _f =60mA
Reverse Current	I _r	-	60	-	uA	V _r =10V
Dominant wave length	λ _p	568	572	575	nm	I _f =60mA
Spectral Line Half width	Δ λ	-	30	-	-	I _f =60mA
Luminance	L _v	-	50	-	cd/m ²	I _f =60mA

4.2 LED ABSOLUTE MAXIMUM RATINGS

Item	Symbol	Condition	Rating	Unit
Reverse Voltage	V _r	T _a =25°C	10	V
Absolute maximum forward current	I _{fm}	T _a =25°C	80	mA
Power description	pd	T _a =25°C	400	mW

4.2.1 LED ARRAY BLOCK DIAGRAM (LED DICE 2×4= 8 dices)

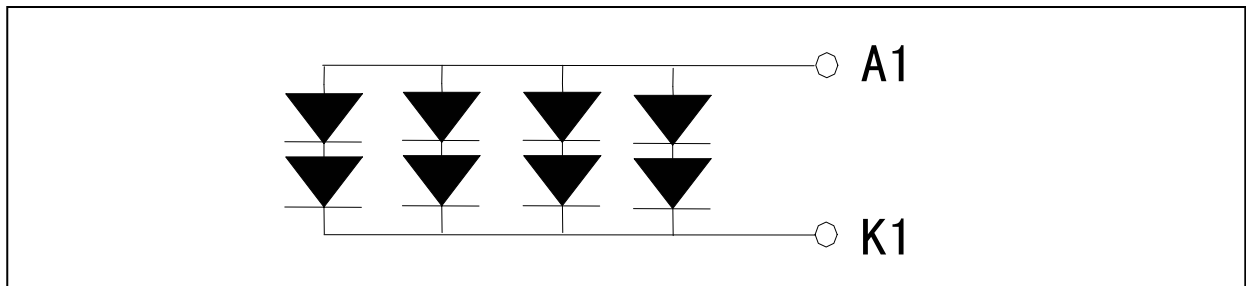

4.2.2 LED POWER SOURCE

	Option	Power source	Jumper setting
LED	A	15A/16K	R14, R16, R17
	B	15K/16A	R13, R15, R17
	C	VDD/VSS	R14, R16, R17, R18, R19
GND	FRM GND		R20

5. ELECTRO-OPTICAL CHARACTERISTICS

ITEM	SYMBOL	CONDITION	MIN.	TYP.	MAX.	UNIT	NOTE
Contrast ratio	K	$\phi=0$	1.4	4	-	-	1
Response time (rise)	T_r	$\phi=0$	-	250	300	ms	2
Response time (fall)	T_f	$\phi=0$	-	250	350	ms	2
Viewing angle	ϕ	$K \geq 2.0$	-40 -- +40			deg.	3
	θ		-30 -- +30				

Note 1: Definition of Contrast Ratio "K"

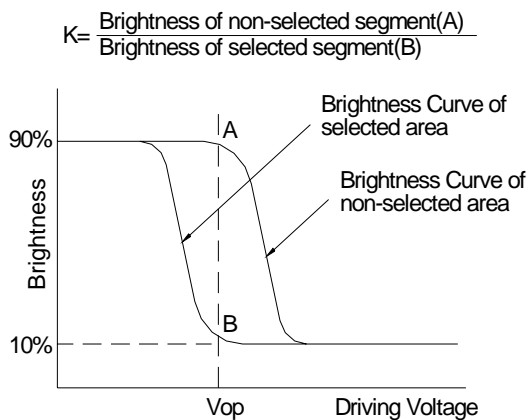

Note 2: Definition of Optical Response Time

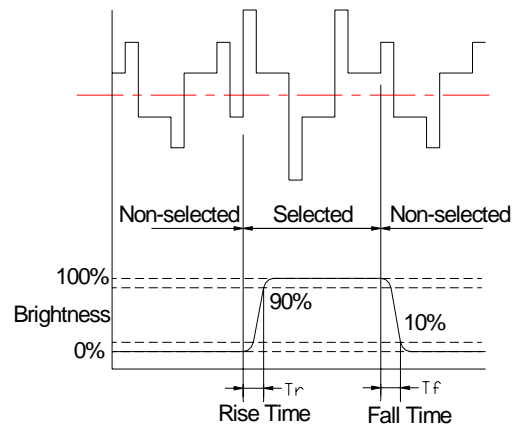

Note 3: Definition of Viewing Angle

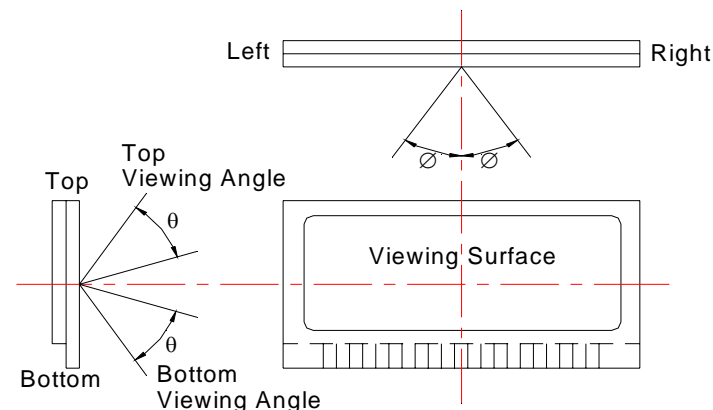

Please select either top or bottom viewing angle

6. BLOCK DIAGRAM

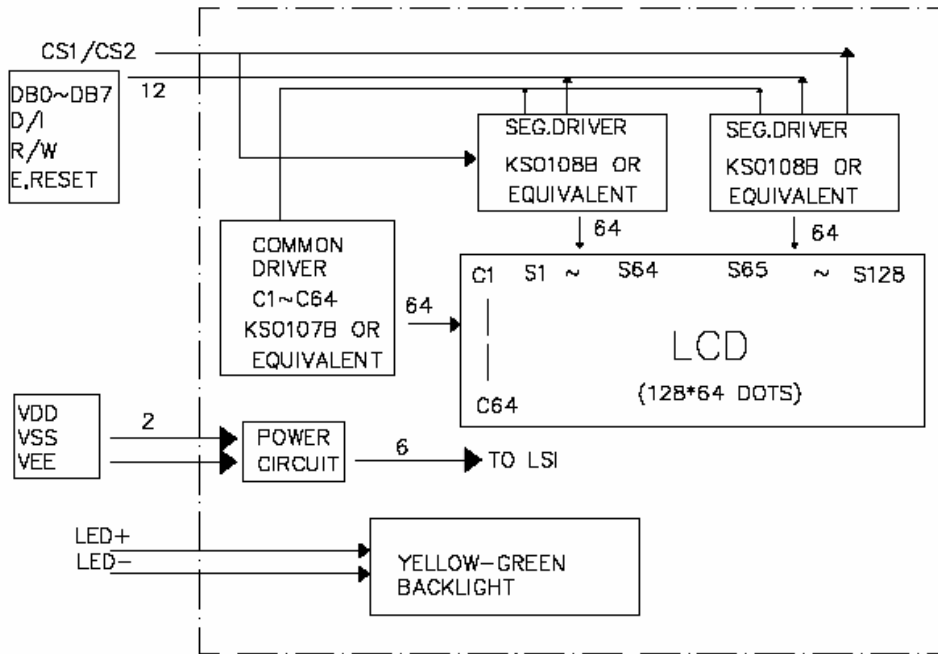

7. VOLTAGE REGULATOR CIRCUITS

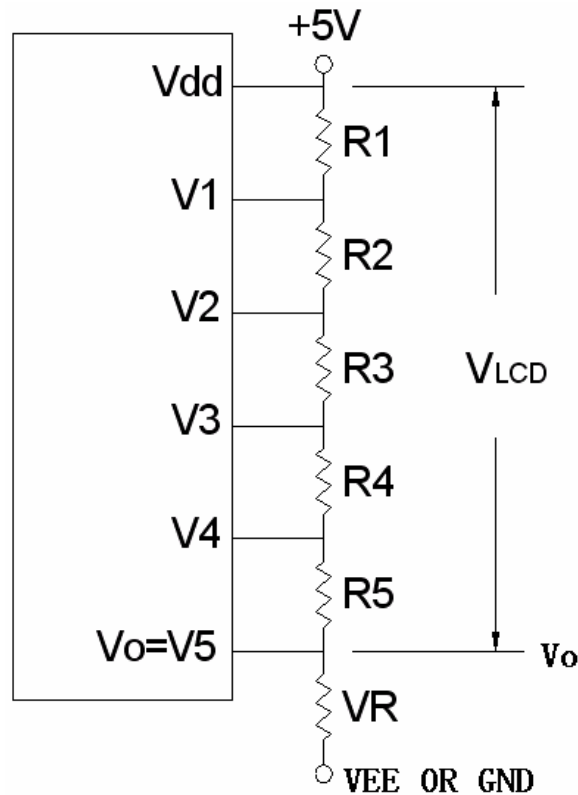

8. TIMING DIAGRAM

MPU Interface

Characteristic	Symbol	Min	Typ	Max	Unit
E Cycle	t_c	1000	--	--	ns
E High Level Width	t_{WH}	450	--	--	ns
E Low Level Width	t_{WL}	450	--	--	ns
E Rise Time	t_R	--	--	25	ns
E Fall Time	t_F	--	--	25	ns
Address Set-Up Time	t_{ASU}	140	--	--	ns
Address Hold Time	t_{AH}	10	--	--	ns
Data Set-Up Time	t_{SU}	200	--	--	ns
Data Delay Time	t_D	--	--	320	ns
Data Hold Time (Write)	t_{DHW}	10	--	--	ns
Data Hold Time (Read)	t_{DHR}	20	--	--	ns

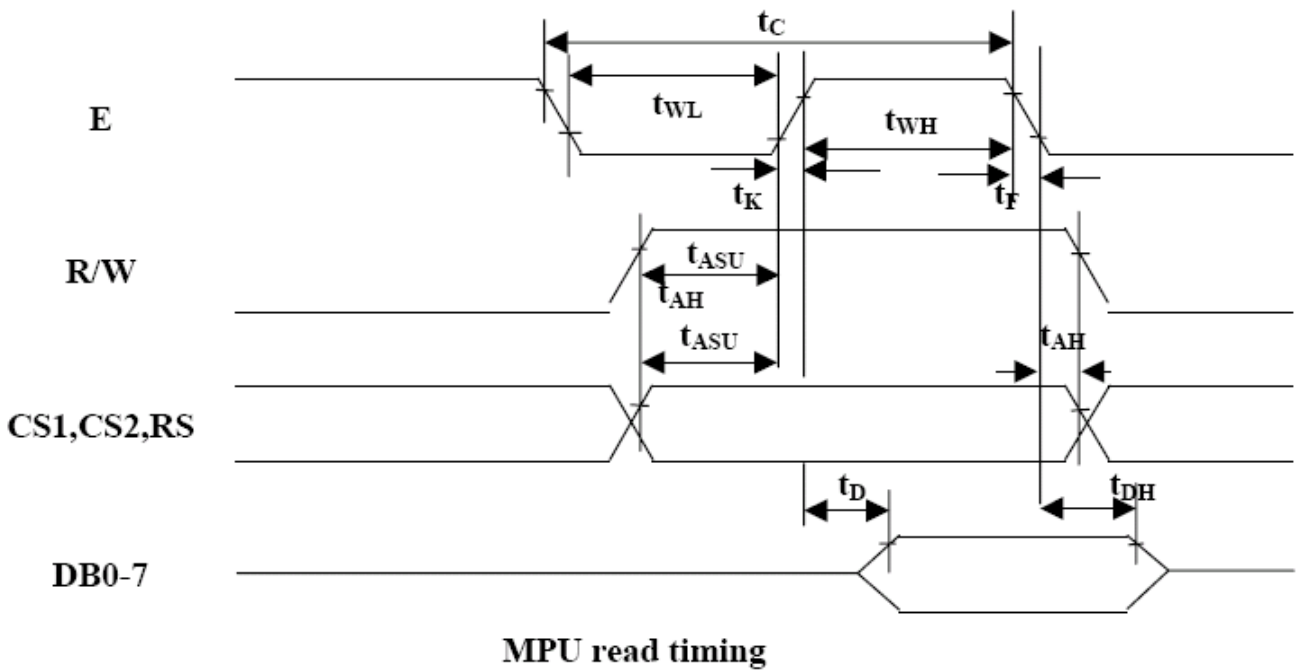
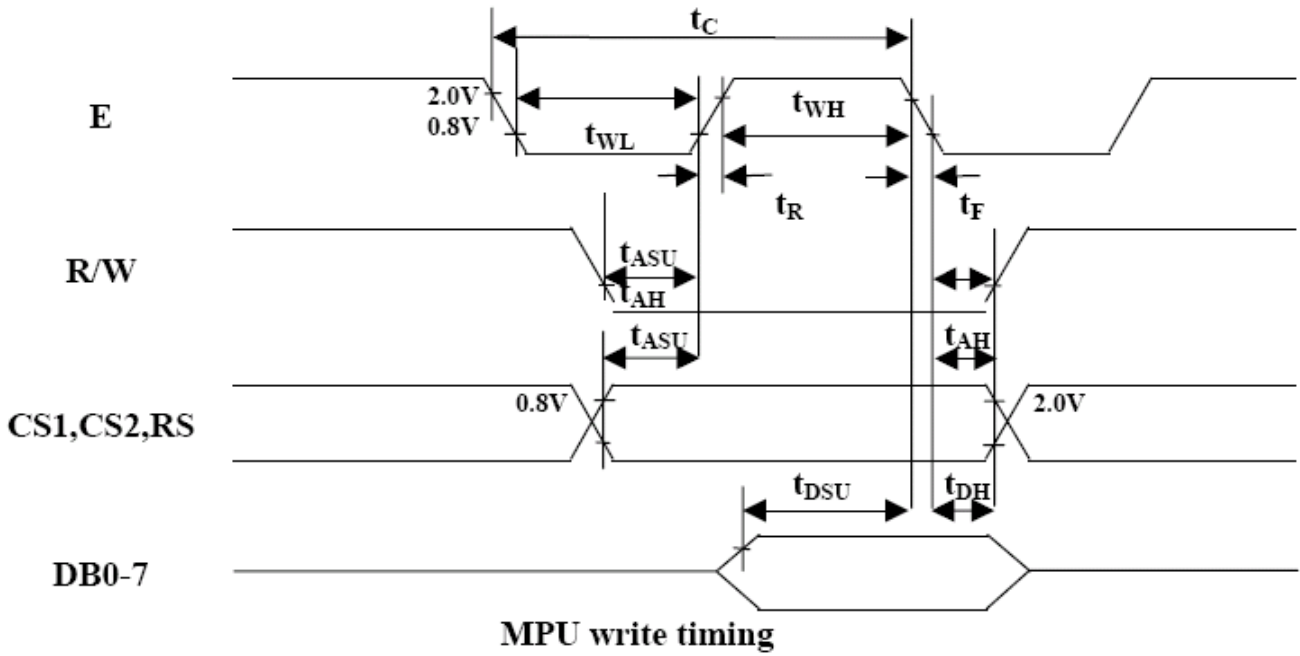

9. INSTRUCTION SET

DISPLAY CONTROL INSTRUCTION

The display control instructions control the internal state of the S6B0108. Instruction is received from MPU to S6B0108 for the display control. The following table shows various instructions.

Instruction	RS	R/W	DB7	DB6	DB5	DB4	DB3	DB2	DB1	DB0	Function	
Display on/off	L	L	L	L	H	H	H	H	H	L/H	Controls the display on or off. Internal status and display RAM data is not affected. L: OFF, H: ON	
Set address (Y address)	L	L	L	H	Y address (0 - 63)						Sets the Y address in the Y address counter.	
Set page (X address)	L	L	H	L	H	H	H	Page (0 - 7)			Sets the X address at the X address register.	
Display start line (Z address)	L	L	H	H	Display start line (0 - 63)						Indicates the display data RAM displayed at the top of the screen.	
Status read	L	H	Busy	L	On/Off	Reset	L	L	L	L	Read status. BUSY L: Ready H: In operation ON/OFF L: Display ON H: Display OFF RESET L: Normal H: Reset	
Write display data	H	L	Write data									Writes data (DB0:7) into display data RAM. After writing instruction, Y address is increased by 1 automatically.
Read display data	H	H	Read data									Reads data (DB0:7) from display data RAM to the data bus.

10. INITIALIZATION SEQUENCE

INIT:

```
MOV A,#0C0H ;Display 0star line
LCALL WC1
LCALL WC2
MOV A,#3FH ;Display on
LCALL WC1
LCALL WC2
RET
```

11. EXTERNAL DIMENSION

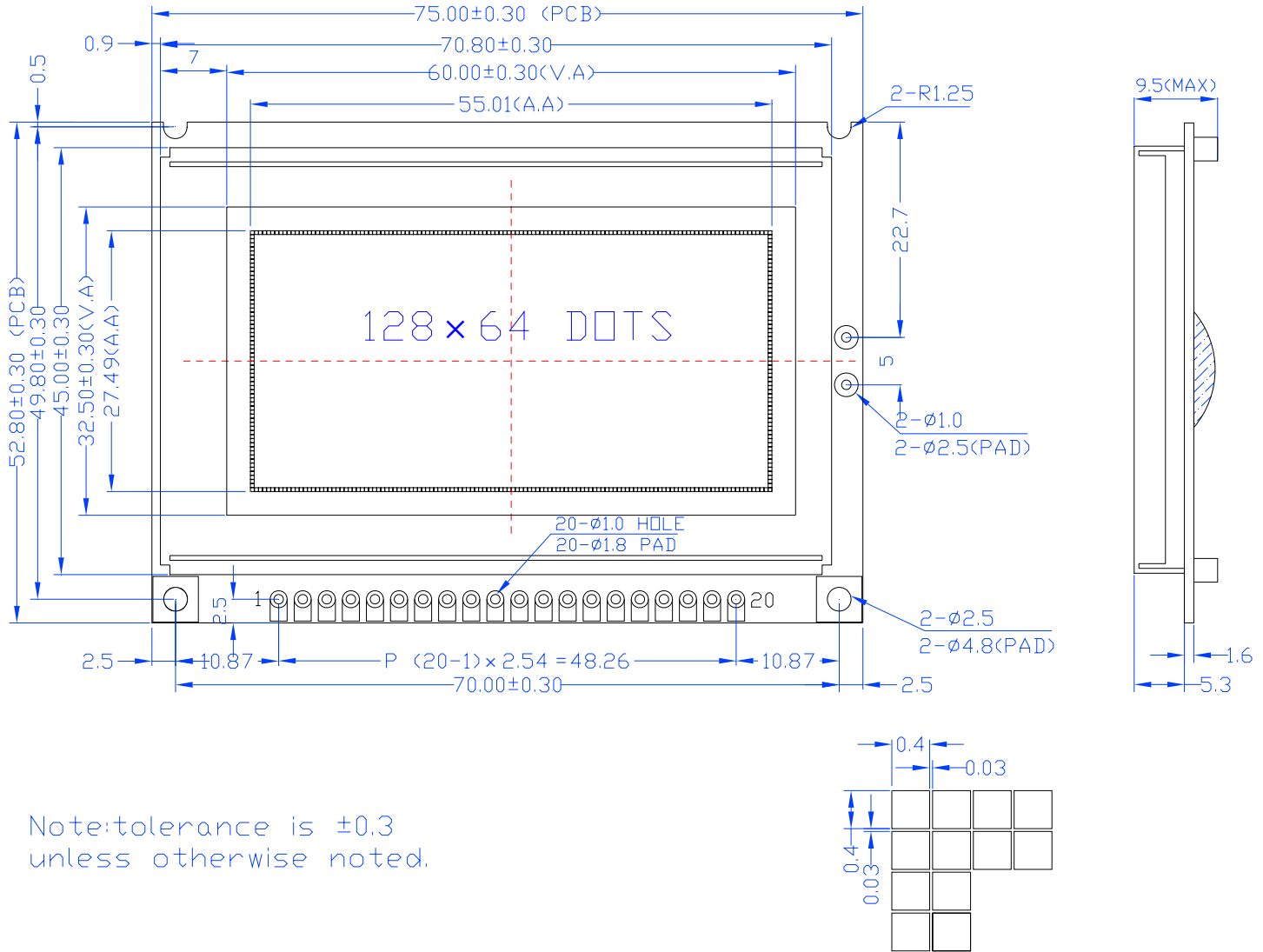

Note: tolerance is ± 0.3 unless otherwise noted.

12.INTERFACE

No.	Symbol	Function
1	V _{DD}	+5V
2	V _{SS}	Ground (0V)
3	V ₀	Power Supply input For LCD Drive
4	DB0	Data Bus Line
5	DB1	
6	DB2	
7	DB3	
8	DB4	
9	DB5	
10	DB6	
11	DB7	
12	/CS1	Chip select for IC1, Active LOW
13	/CS2	Chip select for IC2, Active LOW
14	/RST	Reset, Active LOW
15	R/W	H→ Data Read (LCD → MPU) L→ Data Write (LCD ← MPU)
16	D/I	L→ Instructions H→ Data
17	E	Enable Signal
18	VEE	Negative Voltage output
19	LEDA	LED Anode. Power Supply +
20	LEDK	LED Cathode. Power Supply -

13. PACKAGE INFORMATION

A Box include 40pcs

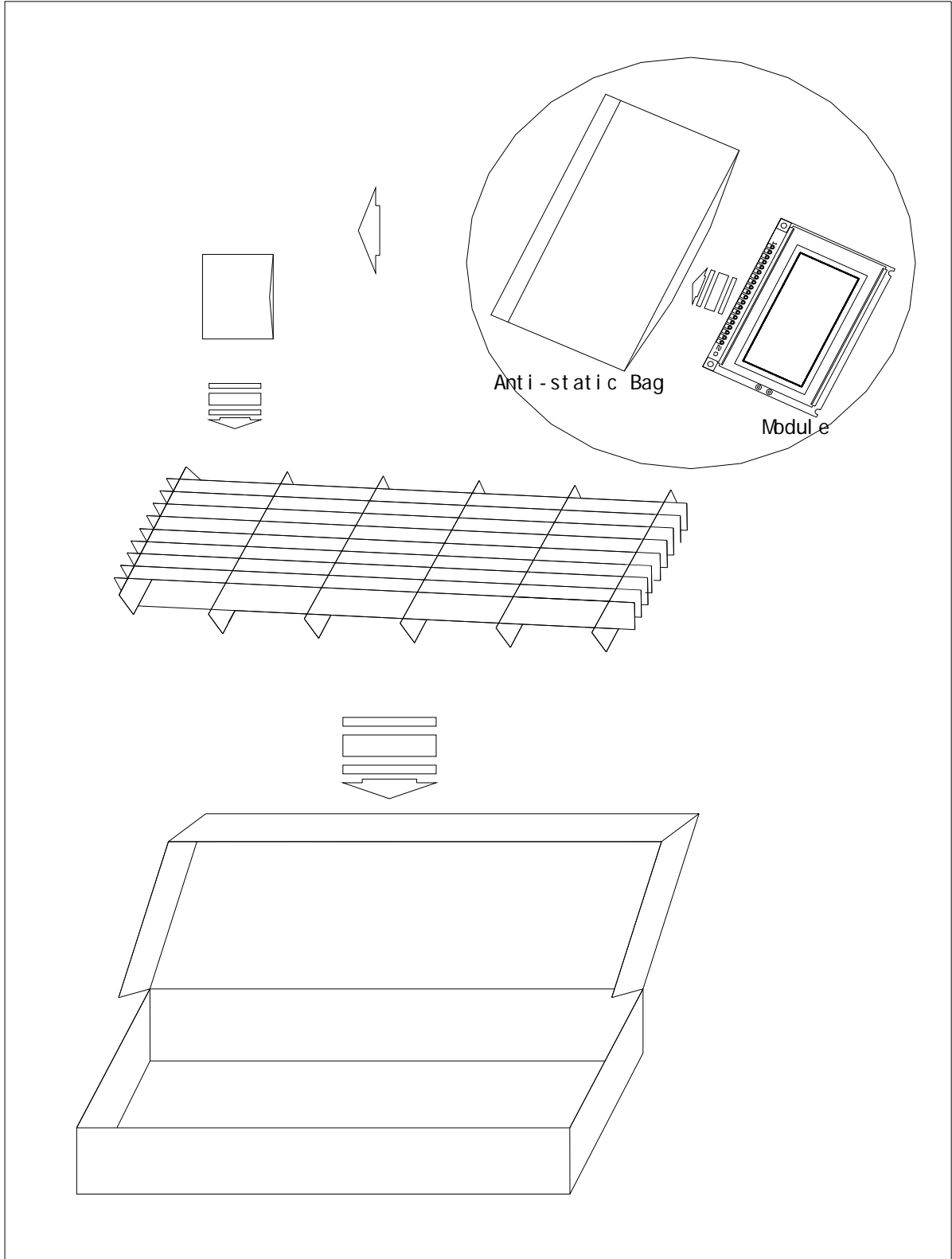

14. QC/QA PROCEDURE

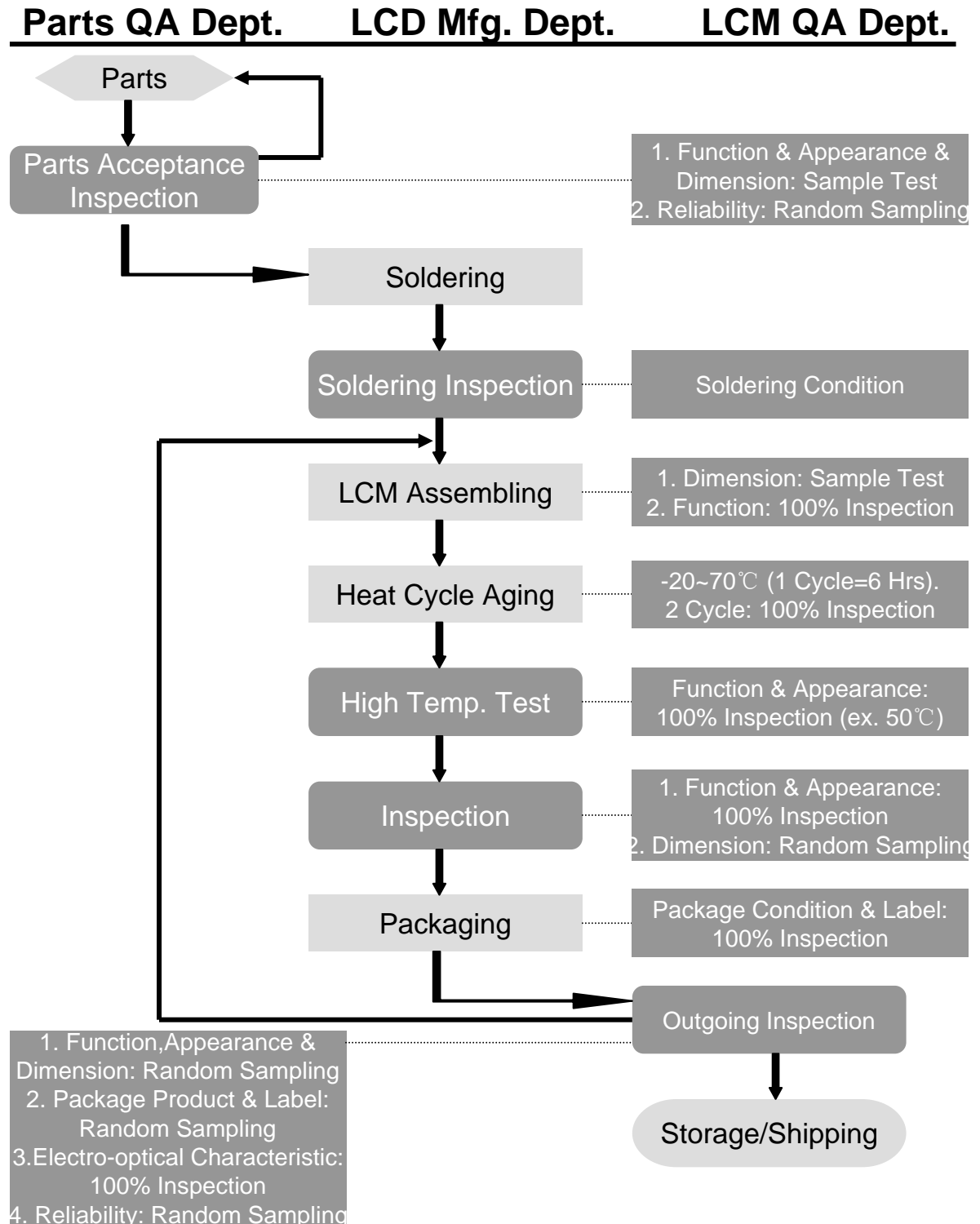

15. RELIABILITY

•Operating life time:

Longer than 50000 hours (at room temperature without direct irradiation of sunlight)

•Reliability Characteristics:

Item	Test	Criterion
High temp	70°C / 200 Hrs	■Total current consumption should be below double of initial value ■Contrast ratio should be within initial value $\pm 50\%$ ■No defect in cosmetic and operational function is allowable
Low temp.	-20°C / 200 Hrs	
High humidity	40°C * 90%RH / 200 Hrs	
Thermal shock	-20°C → 25°C → 70°C → 25°C /5 Cycles (30min) (5min) (30min) (5min)	
Vibration	1.Operating time: Thirty minutes exposure in each direction (x, y, z) 2.Sweep Frequency (1min):10Hz → 55Hz → 10Hz 3.Amplitude: 0.75mm double amplitude	

16. INSPECTION CONDITION

- The LCD shall be inspected under 40W white fluorescent light

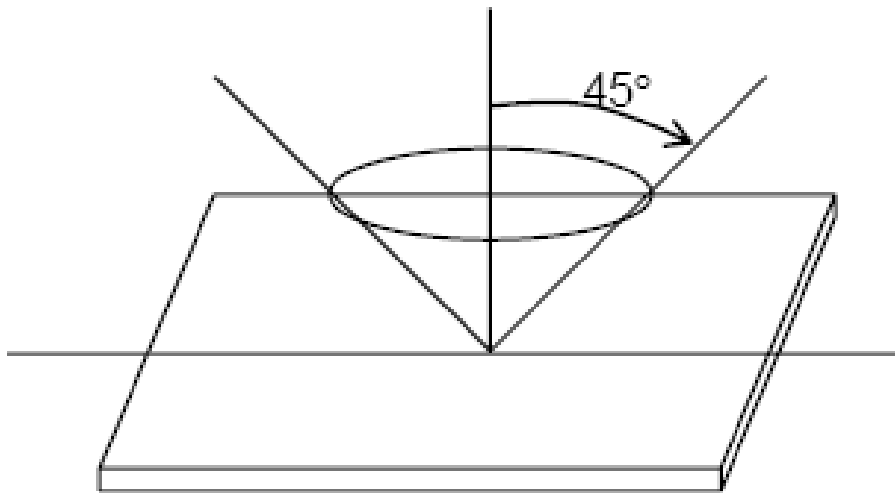

- Definition of applicable zones

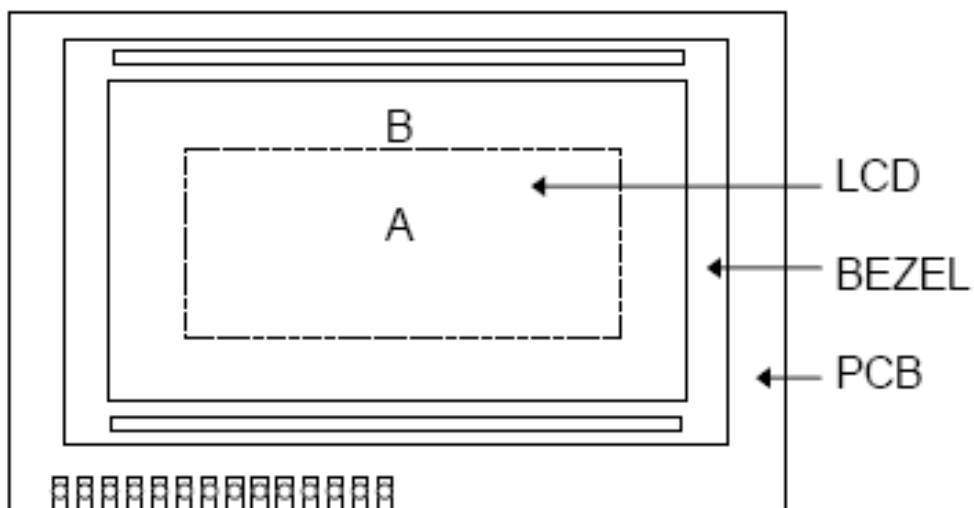

A : Display Area
B : Non-Display Area

• INSPECTION PARAMETERS

NO	Parameter	Criteria																										
1	Black or White spots	<table border="1"> <thead> <tr> <th rowspan="2">Zone Dime Dimension</th> <th colspan="2">Acceptable number</th> <th rowspan="2">Class of Defects</th> <th rowspan="2">AQL Level</th> </tr> <tr> <th>A</th> <th>B</th> </tr> </thead> <tbody> <tr> <td>$D < 0.15$</td> <td>*</td> <td>*</td> <td rowspan="4">Minor</td> <td rowspan="4">2.5</td> </tr> <tr> <td>$0.15 \leq D < 0.2$</td> <td>4</td> <td>4</td> </tr> <tr> <td>$0.2 \leq D \leq 0.25$</td> <td>2</td> <td>2</td> </tr> <tr> <td>$D \leq 0.3$</td> <td>0</td> <td>1</td> </tr> </tbody> </table> <p style="text-align: center;">$D = (\text{Long} + \text{Short}) / 2$ * : Disregard</p>	Zone Dime Dimension	Acceptable number		Class of Defects	AQL Level	A	B	$D < 0.15$	*	*	Minor	2.5	$0.15 \leq D < 0.2$	4	4	$0.2 \leq D \leq 0.25$	2	2	$D \leq 0.3$	0	1					
Zone Dime Dimension	Acceptable number			Class of Defects	AQL Level																							
	A	B																										
$D < 0.15$	*	*	Minor	2.5																								
$0.15 \leq D < 0.2$	4	4																										
$0.2 \leq D \leq 0.25$	2	2																										
$D \leq 0.3$	0	1																										
2	Scratch, Substances	<table border="1"> <thead> <tr> <th rowspan="2">X(mm) Y(m)</th> <th rowspan="2">Zone Y(m)</th> <th colspan="2">Acceptable number</th> <th rowspan="2">Class of Defects</th> <th rowspan="2">AQL Level</th> </tr> <tr> <th>A</th> <th>B</th> </tr> </thead> <tbody> <tr> <td>*</td> <td>$0.04 \geq W$</td> <td>*</td> <td>*</td> <td rowspan="4">Minor</td> <td rowspan="4">2.5</td> </tr> <tr> <td>$3.0 \geq L$</td> <td>$0.06 \geq W$</td> <td>4</td> <td>4</td> </tr> <tr> <td>$2.0 \geq L$</td> <td>$0.08 \geq W$</td> <td>2</td> <td>3</td> </tr> <tr> <td>--</td> <td>$0.1 < W$</td> <td>0</td> <td>1</td> </tr> </tbody> </table> <p style="text-align: center;">X : Length Y : Width * : Disregard Total defects should not exceed 4/module</p>	X(mm) Y(m)	Zone Y(m)	Acceptable number		Class of Defects	AQL Level	A	B	*	$0.04 \geq W$	*	*	Minor	2.5	$3.0 \geq L$	$0.06 \geq W$	4	4	$2.0 \geq L$	$0.08 \geq W$	2	3	--	$0.1 < W$	0	1
X(mm) Y(m)	Zone Y(m)	Acceptable number			Class of Defects	AQL Level																						
		A	B																									
*	$0.04 \geq W$	*	*	Minor	2.5																							
$3.0 \geq L$	$0.06 \geq W$	4	4																									
$2.0 \geq L$	$0.08 \geq W$	2	3																									
--	$0.1 < W$	0	1																									
3	Air Bubbles (between glass & polarizer)	<table border="1"> <thead> <tr> <th rowspan="2">Zone Dime Dimension</th> <th colspan="2">Acceptable number</th> <th rowspan="2">Class of Defects</th> <th rowspan="2">AQL Level</th> </tr> <tr> <th>A</th> <th>B</th> </tr> </thead> <tbody> <tr> <td>$D \leq 0.15$</td> <td>*</td> <td>*</td> <td rowspan="3">Minor</td> <td rowspan="3">2.5</td> </tr> <tr> <td>$0.15 < D \leq 0.25$</td> <td>2</td> <td>*</td> </tr> <tr> <td>$0.25 < D$</td> <td>0</td> <td>1</td> </tr> </tbody> </table> <p>* : Disregard Total defects shall not excess 3/module</p>	Zone Dime Dimension	Acceptable number		Class of Defects	AQL Level	A	B	$D \leq 0.15$	*	*	Minor	2.5	$0.15 < D \leq 0.25$	2	*	$0.25 < D$	0	1								
Zone Dime Dimension	Acceptable number			Class of Defects	AQL Level																							
	A	B																										
$D \leq 0.15$	*	*	Minor	2.5																								
$0.15 < D \leq 0.25$	2	*																										
$0.25 < D$	0	1																										

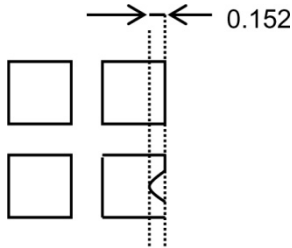
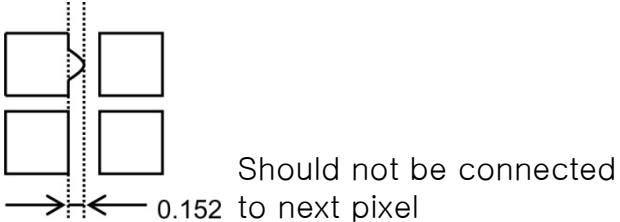
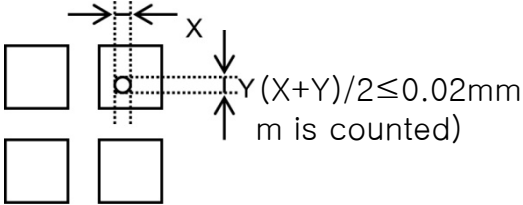
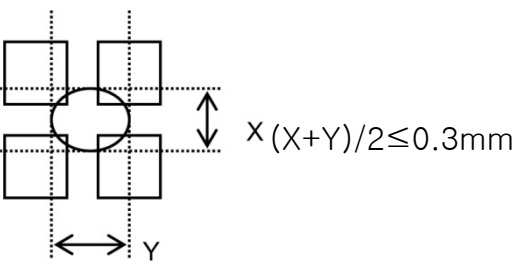
4	Uniformity of Pixel	<p>(1) Pixel shape (with Dent)</p>  <p>(2) Pixel shape (with Projection)</p>  <p>(3) Pin hole</p>  <p>(4) Deformation</p>  <p>Total acceptable number : 1/pixel, 5/cell</p>	
Class of defects	Major	AQL 0.65%	Definition
		AQL 1.00%	It is a defect that is likely to result in failure or to reduce materially the usability of the product for the intended function.
	Minor	AQL 2.5%	It is a defect that will not result in functioning problem with deviation classified.

17. Handling Precaution

1. Limitation of Application:

Optrex products are designed for use in ordinary electronic devices such as business machines, telecommunications equipment, measurement devices and etc. Please handle the products with care. (see below)

Optrex products are not designed, intended, or authorized for use in any application which the failure of the product could result in a situation where personal injury or death may occur. These applications include, but are not limited to, life-sustaining equipment, nuclear control devices, aerospace equipment, devices related to hazardous or flammable materials, etc. [If Buyer intends to purchase or use the Optrex Products for such unintended or unauthorized applications, Buyer must secure prior written consent to such use by a responsible officer of Optrex Corporation.] Should Buyer purchase or use Optrex Products for any such unintended or unauthorized application [without such consent], Buyer shall indemnify and hold Optrex and its officers, employees, subsidiaries, affiliates and distributors harmless against all claims, costs, damages and expenses, and reasonable attorney's fees, arising out of, directly or indirectly, any claim of personal injury or death associated with such unintended or unauthorized use, even if such claim alleges that Optrex was negligent regarding the design or manufacture of the part.

2. Industrial Rights and Patents

Optrex shall not be responsible for any infringement of industrial property rights of third parties in any country arising out of the application or use of Optrex products, except which directly concern the structure or production of such products.

No Press and Shock!

If pressure to LCD, orientation may be disturbed.
LCD will broken by shock!

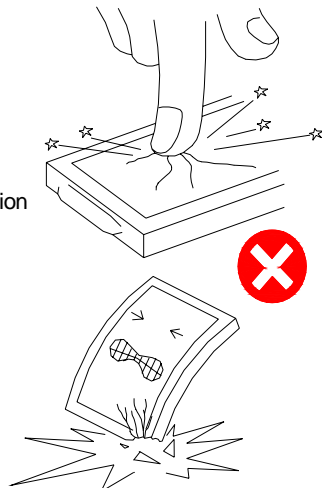

Don't Swallow or Touch Liquid Crystal!

Liquid Crystal may be leaked when display is broken.
If it accidentally gets your hands, wash then with water!

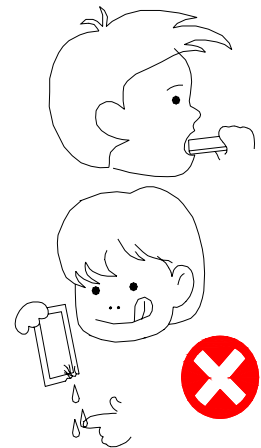

Don't not Scratch!

Polarizer is a soft material and can easily be scratched.

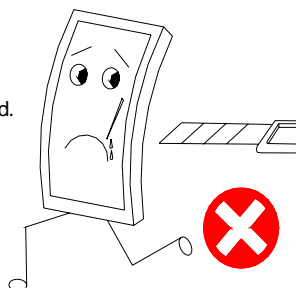

No DC Voltage to LCD!

DC voltage or driving higher than the specified voltage will reduce the lifetime of the LCD.

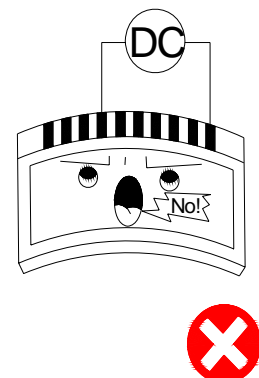

Don't Press the Metallic Frame and Disassemble the LCM

Pressure on the metallic frame and PCB may deform the conductive rubber or break the liquid crystal cell and back light, which will cause defects.

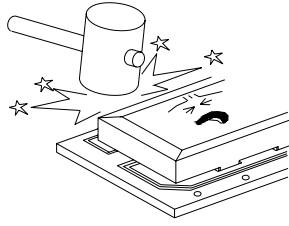

LCD may be shifted or conductive rubber may be reshaped, which will cause defects.

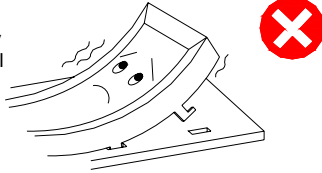

Slowly Peel Off Protective Film!

Avoid static electricity.

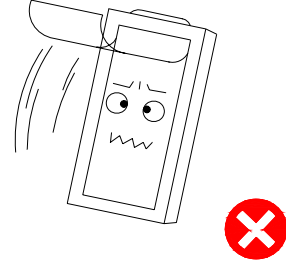

Avoid Static Electricity!

Please be sure to ground human body and electric appliances during work. It is preferable to use conductive mat on table and wear cotton clothes or conduction processed fiber. Synthetic fiber is not recommended.

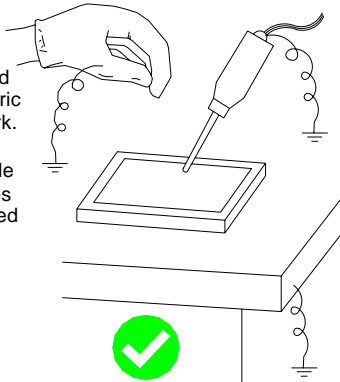

Wear Gloves While Handling!

It is preferable to wear gloves to avoid damaging the LCD.

Please do not touch electrodes with bare hands or make them dirty.

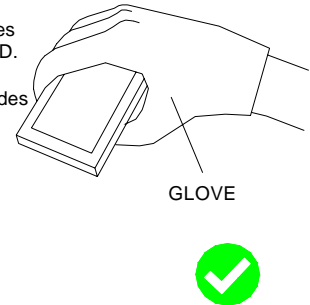

Keep Away From Extreme Heat and Humidity!

LCD deteriorates.

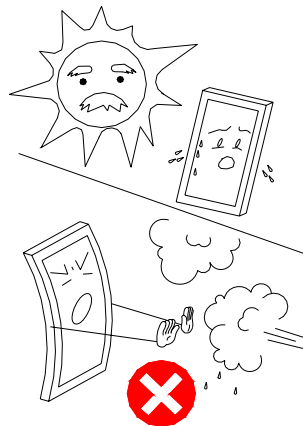

Use Alcohol to Clean Terminals!

When attaching with the heat seal or anisotropically conductive film, wipe off with alcohol before use.

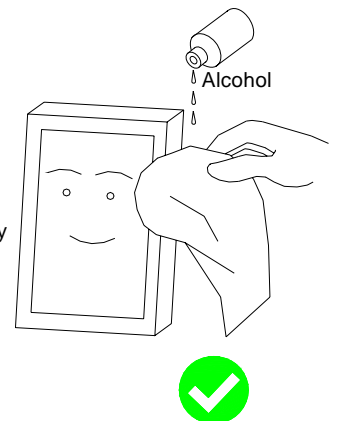

Don't Drop Water on LCD!

Note that the presence of waterdrops or dew in the LCD panel may deteriorate the polarizer or corrode electrode.

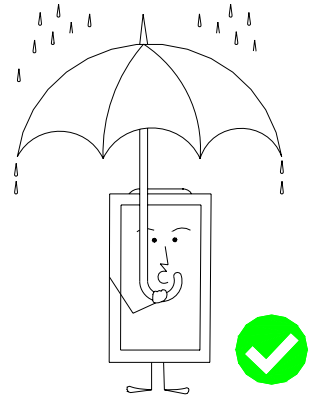
**Precaution in Soldering LCD Module**

Basic instructions: Solder I/O terminals only.
Use soldering iron without leakage.

(1) Soldering condition to I/O terminals

Temperature at tip of the iron: $280 \pm 10^{\circ}\text{C}$

Soldering time: 3~4 sec.

Type of solder: Eutectic solder (containing colophony-flux)

*Please do not use flux because it may soak into LCD Module or contaminate it.

*It is preferable to peel off protective film on display surface after soldering I/O terminals is finished.

(2) Remove connector or cable

*When you remove connector or cable soldered to I/O terminals, please confirm that solder is fully melted. If you remove by force, electrodes at I/O terminals may be damaged (or stripped off).

*It is recommended to use solder suction machine.

Long-term Storage

If it is necessary to store LCD modules for a long time, please comply with the following procedures.

If storage condition is not satisfactory, display (especially polarizer) may be deteriorated or soldering I/O terminals may become difficult (some oxide is generated at I/O terminals plating).

1. Store as delivered by Optrex

2. If you store as unpacked, put in anti-static bag, seal its opening and store where it is not subjected to direct sunshine nor fluorescent lamp.

3. Store at temperature 0 to $+35^{\circ}\text{C}$ and at low humidity. Please refer to our specification sheets for storage temperature range and humidity condition.

Long-term Storage

Please use power supply with built-in surge protection circuit.