

SPECIFICATION OF LCD MODULE

CUSTOMER 客户名称	
PART NO. 产品型号	OTM847 G-1
PRODUCTS TYPE 产品内容	
REMARKS 备注	
SIGNATURE BY CUSTOMER 客户签署：	

		
---	---	---

LCM System

1 LCD Type

STN
 FSTN
 DFSTN

2 Viewing Angle

Lower 6:00
 Upper 12:00
 Others

3 Display Mode

Yellow Green positive
 Blue positive
 Gray positive
 FSTN positive
 FSTN negative

4 Polarizer Mode

Reflective
 Transflective
 Transmissive

5 Connector

Pin
 Heat sealed
 Zebra

6 Thickness of Glass

1.1mm
 0.4mm
 0.55mm
 0.7mm

7 Backlight Mode:

LED
 CCFL

8 Backlight Color

Blue
 Amber
 Yellow Green
 Red
 White
 Without backlight

9 Temperature Grade

Normal temperature
 Wide temperature
 Super wide temperature

10 CG-ROM

01 for English + Japanese language

•REVISION RECORD

REV. NO.	REV. DATE	DESCRIPTION OF REVISION	PAGE	REMARK
1.0	21/07/08	INITIAL RELEASE	ALL	

CONTENTS

1.	FEATURES	5
2.	MECHANICAL SPEC	5
3.	ABSOLUTE MAXIMUM RATING	6
4.	ELECTRICAL CHARACTERISTICS	6
5.	ELECTRO-OPTICAL CHARACTERISTICS	8
6.	BLOCK DIAGRAM	9
7.	POWER SUPPLY	9
8.	TIMIING DIAGRAM	10
9.	AC CHARACTERISTICS	11
10.	INSTRUCTION SET	12
11.	INITIALIZATION SEQUENCE	13
12.	FONT TABLE	14
13.	OUTLINE DRAWING	15
14.	INTERFACE	16
15.	QC/QA PROCEDURE	17
16.	RELIABILITY	18
17.	HANDING PRECAUTIONS	19

1. FEATURES

•Display construction	16 Characters * 2 Lines
•Display mode	STN(GRAY)
•Display type	Positive Reflective
•Backlight	NO
•Viewing direction	6 o'clock
•Operating temperature	-20 to 70°C
•Storage temperature	-30 to 80°C
•Controller	SPLC780D or Equivalence
•Driving voltage	Single power
•Driving method	1/16 duty, 1/5 bias
•Type	COB (Chip On Board)
•Number of data line	6800 4/8-bit parallel
•Connector	PIN

2. MECHANICAL DATA

ITEM		WIDTH	HEIGHT	THICKNESS	UNIT
Module size		85.0	29.5	10.0MAX)	mm
Viewing area		62.2	17.9	-	mm
character	Construction	5*7			dots
	Size	2.95	5.55	-	mm
	Pitch	3.55	5.95	-	mm
Dot	Size	0.55	0.65	-	mm
	Pitch	0.6	0.7	-	mm
Diameter of mounting hole		R1.3			mm
Weight		About 50			g

3. ABSOLUTE MAXIMUM RATINGS

(TA = 25 , Vss=0V)

Item	Symbol	MIN.	Max.	Unit
Supply Voltage (Logic)	VDD-VSS	0	7.0	V
Supply Voltage (LCD Driveer)	V _{LCD}	VDD-12	VDD+0.3	V
Input Voltage	V _{IN}	-0.3	VDD+0.3	V
Operating temperature	Top	0	50	°C
Storage temperature	Tsto	-10	60	°C

4. ELECTRICAL CHARACTERISTICS

(VDD 4.5 to 5.5V , TA = 25)

Characteristic	Symbol	Condition	Min	Typ	Max	Unit
Operating Voltage	V _{DD}	-	4.5	-	5.5	V
Operating Current	I _{DD}	Internal oscillation or external clock (V _{DD} = 5.0V, fosc = 270kHz)	-	0.35	0.6	mA
Input Voltage (1) (except OSC1)	V _{IH1}	-	2.2	-	V _{DD}	V
	V _{IL1}	-	-0.3	-	0.6	
Input Voltage (2) (OSC1)	V _{IH2}	-	V _{DD} -1.0	-	V _{DD}	V
	V _{IL2}	-	-0.2	-	1.0	
Output Voltage (1) (DB0 to DB7)	V _{OH1}	I _{OH} = -0.205mA	2.4	-	-	V
	V _{OL1}	I _{OL} = 1.2mA	-	-	0.4	
Output Voltage (2) (except DB0 to DB7)	V _{OH2}	I _O = -40μA	0.9V _{DD}	-	-	V
	V _{OL2}	I _O = 40μA	-	-	0.1V _{DD}	
Voltage Drop	V _{dCOM}	I _O = ±0.1mA	-	-	1	V
	V _{dSEG}		-	-	1	
Input Leakage Current	I _{LKG}	V _{IN} = 0V to V _{DD}	-1	-	1	μA
Input Low Current	I _{IL}	V _{IN} = 0V, V _{DD} = 5V (pull up)	-50	-125	-250	
Internal Clock (external Rf)	f _{OSC1}	Rf = 91kΩ ±2% (V _{DD} = 5V)	190	270	350	kHz
External Clock	f _{OSC}	-	125	270	350	kHz
	duty		45	50	55	%
	t _R , t _F		-	-	0.2	μA
LCD Driving Voltage	V _{LCD}	V _{DD} -V5 (1/5, 1/4 bias)	3.0	-	13.0	V

4.1 LED ELECTRICAL/OPTICAL CHARACTERISTICS

Item	Symbol	min	typ	max	Unit	Condition
Forward Voltage	V _f	-	-	-	V	I _f = mA
Reverse Current	I _r	-	-	-	μA	V _r = V
Dominant wave length	λ _d	-	-	-	nm	I _f = mA
Spectral Line Half width	Δ λ	-	-	-	nm	I _f = mA
Luminance	L _v	-	-	-	cd/m ²	I _f = mA

4.2 LED ABSOLUTE MAXIMUM RATINGS

Item	Symbol	Condition	Rating	Unit
Reverse Voltage	V _r	T _a =25 °C	-	V
Absolute maximum forward current	I _{fm}	T _a =25 °C	-	mA
Power description	p _d	T _a =25 °C	-	mW

4.2.1 LED ARRAY BLOCK DIAGRAM

(LED DICE × = dices)



4.2.2 LED POWER SOURCE

LED	Option	Power source	Jumper setting

5. ELECTRO-OPTICAL CHARACTERISTICS

ITEM	SYMBOL	CONDITIO N	MIN.	TYP.	MAX.	UNIT	NOTE
Contrast ratio	K	$\Phi=0^{\circ}$	1.4	4	-	-	1
Response time (rise)	Tr	$\Phi=0^{\circ} \theta=0^{\circ}$	-	130	-	ms	2
Response time (fall)	Tf	$\Phi=0^{\circ} \theta=0^{\circ}$		130	-	ms	2
Viewing angle	Φ	K ≥ 1.4	-40 -- +10			deg.	3
	θ		-40 -- +30				

Note 1: Definition of Contrast Ratio "K"

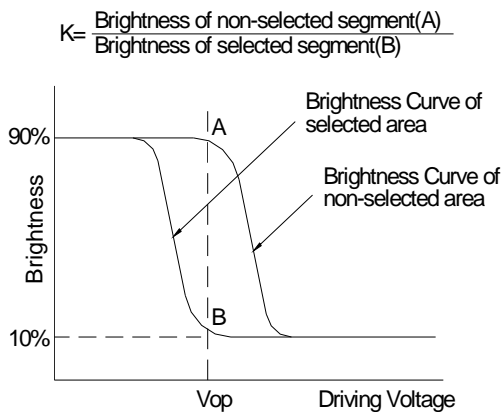

Note 2: Definition of Optical Response Time

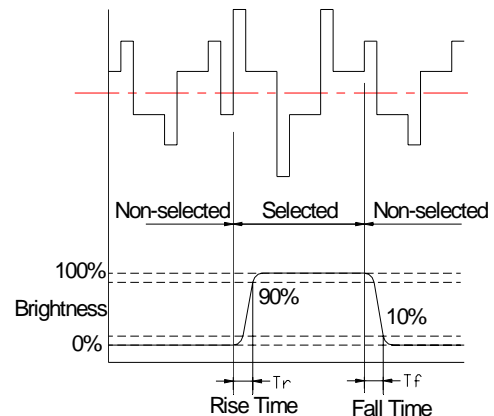

Note 3: Definition of Viewing Angle

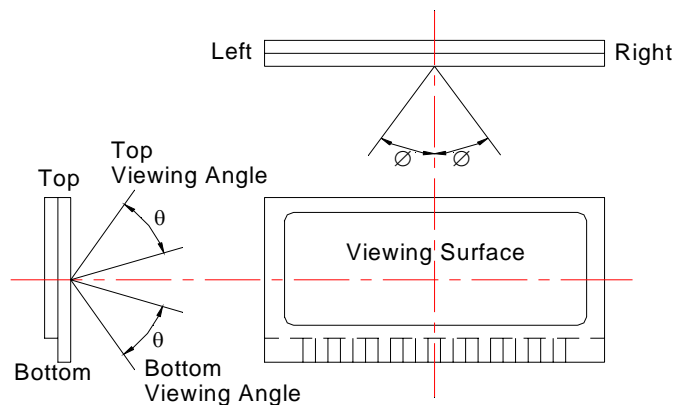

Please select either top or bottom viewing angle

6. BLOCK DIAGRAM

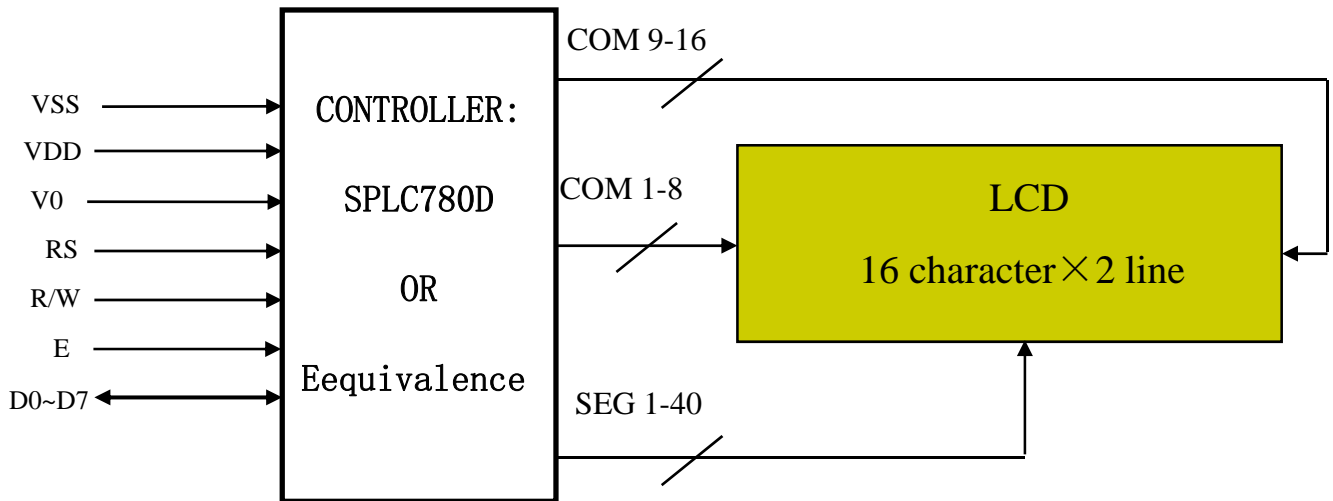

7. POWER SUPPLY

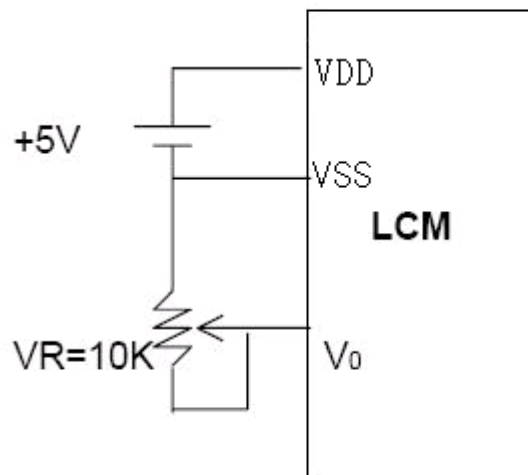

8. TIMING DIAGRAM

• WRITE OPERATION

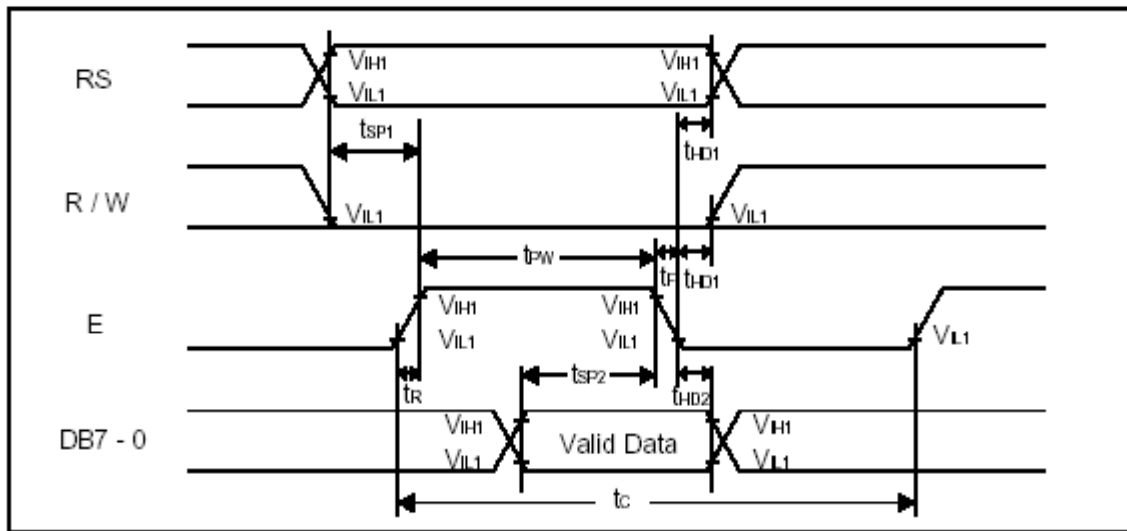

• READ OPERATION

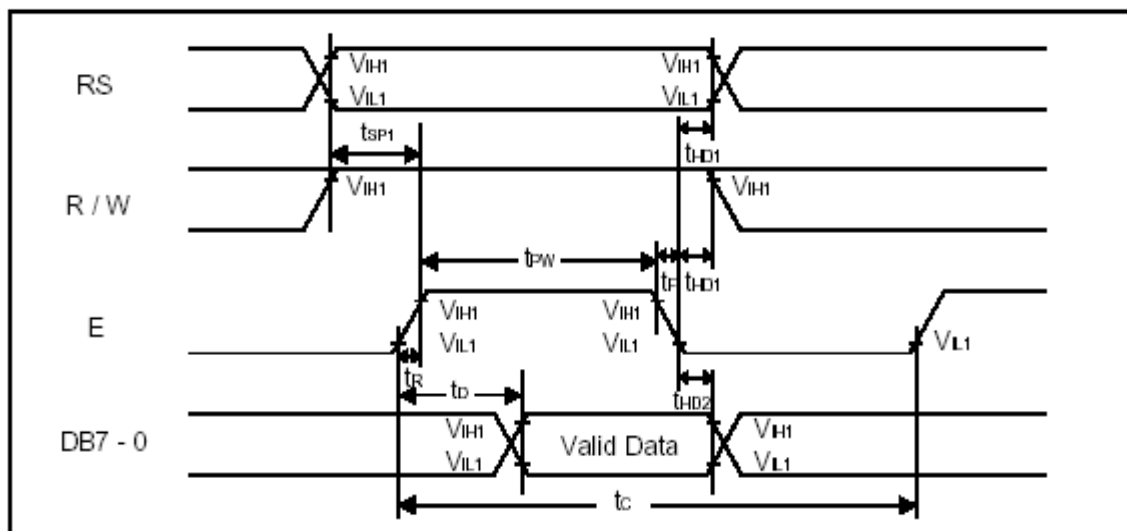

9. AC CHARACTERISTICS

• WRITE MODE

Characteristics	Symbol	Limit			Unit	Test Condition
		Min.	Typ.	Max.		
E Cycle Time	t_c	1000	-	-	ns	Pin E
E Pulse Width	t_{PW}	450	-	-	ns	Pin E
E Rise/Fall Time	t_r, t_f	-	-	25	ns	Pin E
Address Setup Time	t_{SP1}	60	-	-	ns	Pins: RS, R/W, E
Address Hold Time	t_{HD1}	20	-	-	ns	Pins: RS, R/W, E
Data Setup Time	t_{SP2}	195	-	-	ns	Pins: DB7 - 0
Data Hold Time	t_{HD2}	10	-	-	ns	Pins: DB7 - 0

• READ MODE

Characteristics	Symbol	Limit			Unit	Test Condition
		Min.	Typ.	Max.		
E Cycle Time	t_c	1000	-	-	ns	Pin E
E Pulse Width	t_w	450	-	-	ns	Pin E
E Rise/Fall Time	t_r, t_f	-	-	25	ns	Pin E
Address Setup Time	t_{SP1}	60	-	-	ns	Pins: RS, R/W, E
Address Hold Time	t_{HD1}	20	-	-	ns	Pins: RS, R/W, E
Data Output Delay Time	t_D	-	-	360	ns	Pins: DB7 - 0
Data hold time	t_{HD2}	5.0	-	-	ns	Pin DB7 - 0

10. INITIALIZATION SEQUENCE

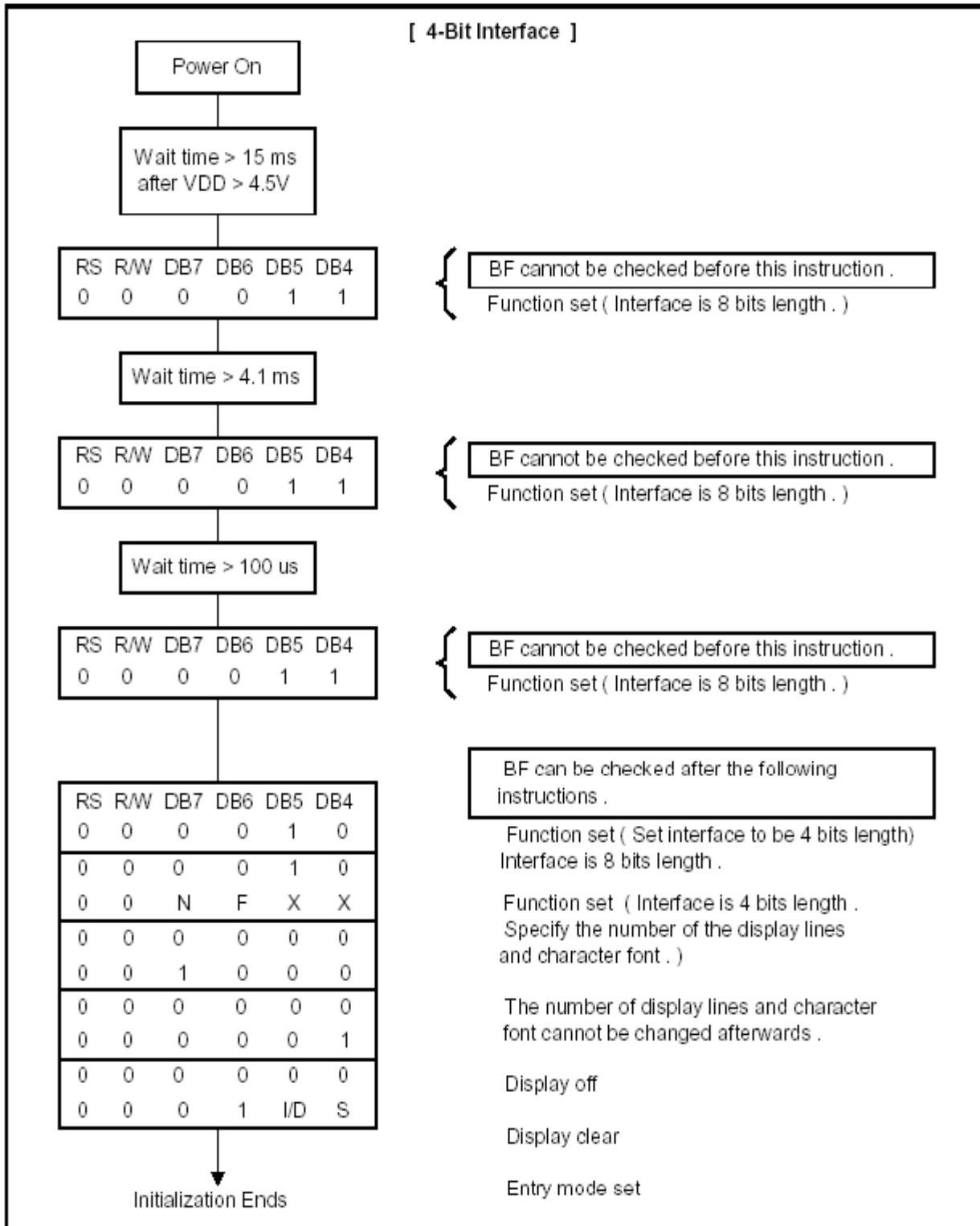

11. INSTRUCTION SET

COMMAND	COMMAND CODE										COMMAND CODE	E-CYCLE $f_{osc}=250\text{KHz}$	
	RS	R/W	DB7	DB6	DB5	DB4	DB3	DB2	DB1	DB0			
SCREEN CLEAR	0	0	0	0	0	0	0	0	0	1	Screen Clear, Set AC to 0 Cursor Reposition	1.64ms	
CURSOR RETURN	0	0	0	0	0	0	0	0	1	*	DDRAM AD=0, Return, Content Changeless	1.64ms	
INPUT SET	0	0	0	0	0	0	0	1	I/D	S	Set moving direction of cursor, Appoint if move	40us	
DISPLAY SWITCH	0	0	0	0	0	0	1	D	C	B	Set display on/off,cursor on/off, blink on/off	40us	
SHIFT	0	0	0	0	0	1	S/C	R/L	*	*	Remove cursor and whole display,DDRAM changeless	40us	
FUNCTION SET	0	0	0	0	1	DL	N	F	*	*	Set DL,display line,font	40us	
CGRAM AD SET	0	0	0	1	ACG							Set CGRAM AD, send receive data	40us
DDRAM AD SET	0	0	1	ADD							Set DDRAM AD, send receive data	40us	
BUSY/AD READ CT	0	1	BF	AC							Executing internal function, reading AD of CT	40us	
CGRAM/ DDRAM DATA WRITE	1	0	DATA WRITE							Write data from CGRAM or DDRAM		40us	
CGRAM/ DDRAM DATA READ	1	1	DATA READ							Read data from CGRAM or DDRAM		40us	
I/D=1: Increment Mode; I/D=0: Decrement Mode S=1: Shift S/C=1: Display Shift; S/C=0: Cursor Shift R/L=1: Right Shift; R/L=0: Left Shift DL=1: 8D DL=0: 4D N=1: 2R N=0: 1R F=1: 5x10 Style; F=0: 5x7 Style BF=1: Execute Internal Function; BF=0: Command Received											DDRAM: Display data RAM CGRAM: Character Generator RAM ACG: CGRAM AD ADD: DDRAM AD & Cursor AD AC: Address counter for DDRAM & CGRAM		E-cycle changing with main frequency. Example: If fcp or $f_{osc}=270\text{KHz}$ 40us x 250/270 =37us

12. FONT TABLE

b7- b3 -b0	b4	0000	0010	0011	0100	0101	0110	0111	1010	1011	1100	1101	1110	1111
0000	CG RAM (1)		0	a	P	`	P		—	㉵	㉶	㉷	㉸	p
	(2)	!	1	A	Q	a	9	9	ア	チ	ㄥ		ä	q
0010	(3)	"	2	B	R	b	r	ㄱ	イ	ㄱ	ㄱ		ß	θ
	(4)	#	3	C	S	c	s	ㄱ	ㄱ	ㄱ	ㄱ		ε	∞
0100	(5)	\$	4	D	T	d	t	ㄱ	ㄱ	ㄱ	ㄱ		μ	Ω
	(6)	%	5	E	U	e	u	ㄱ	ㄱ	ㄱ	ㄱ		ε	Ü
0110	(7)	&	6	F	V	f	v	ㄱ	ㄱ	ㄱ	ㄱ		ρ	Σ
	CG RAM (8)	'	7	G	W	g	w	ㄱ	ㄱ	ㄱ	ㄱ		g	π
1000	CG RAM (1)	(8	H	X	h	x	ㄱ	ㄱ	ㄱ	ㄱ		⌋	⌋
	(2))	9	I	Y	i	y	ㄱ	ㄱ	ㄱ	ㄱ		'	y
1010	(3)	*	:	J	Z	j	z	ㄱ	ㄱ	ㄱ	ㄱ		j	ƒ
	(4)	+	;	K	[k	[ㄱ	ㄱ	ㄱ	ㄱ		*	ƒ
1100	(5)	,	<	L	¥	l	l	ㄱ	ㄱ	ㄱ	ㄱ		⊕	ƒ
	(6)	—	=	M]m)	ㄱ	ㄱ	ㄱ	ㄱ	ㄱ		⊕	÷
1110	(7)	.	>	N	^	n	ㄱ	ㄱ	ㄱ	ㄱ	ㄱ		ƒ	
	CG RAM (8)	/	?	O	_	o	ㄱ	ㄱ	ㄱ	ㄱ	ㄱ		ö	

13. OUTLINE DRAWING

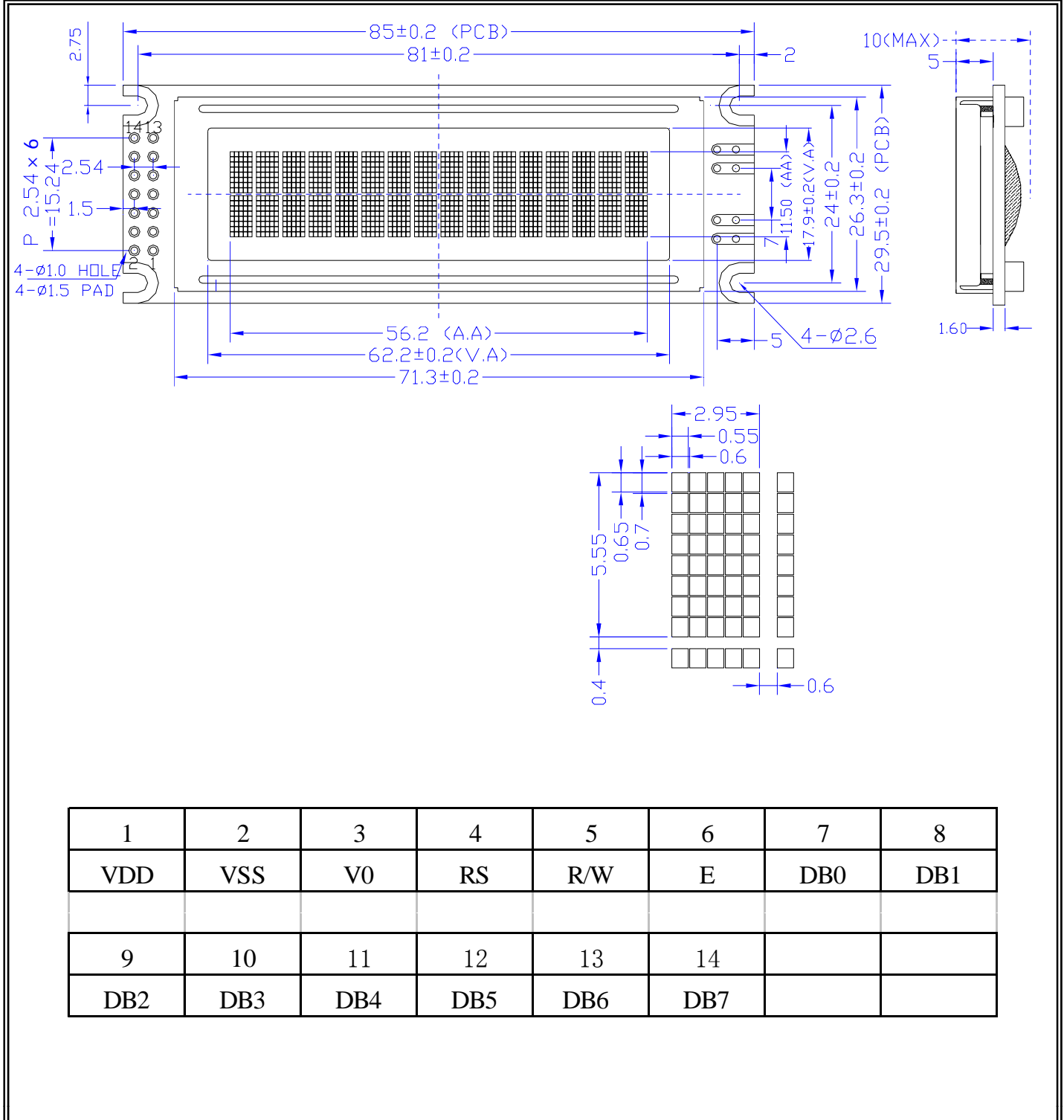

1	2	3	4	5	6	7	8
VDD	VSS	V0	RS	R/W	E	DB0	DB1
9	10	11	12	13	14		
DB2	DB3	DB4	DB5	DB6	DB7		

14. INTERFACE

PIN NO.	SYMBOL	DESCRIPTION	FUNCTION
1	VDD	POWER SUPPLY FOR LOGIC CIRCUIT	+5V
2	VSS	GROUND	0V (GND)
3	V0	LCD CONTRAST ADJUSTMENT	
4	RS	INSTRUCTION/DATA REGISTER SELECTION	RS = 0 : INSTRUCTION REGISTER RS = 1 : DATA REGISTER
5	R/W	READ/WRITE SELECTION	R/W = 0 : REGISTER WRITE R/W = 1 : REGISTER READ
6	E	ENABLE SIGNAL	
7	DB0	DATA INPUT/OUTPUT LINES	8 BIT: DB0-DB7
8	DB1		
9	DB2		
10	DB3		
11	DB4		
12	DB5		
13	DB6		
14	DB7		

15. QC/QA PROCEDURE

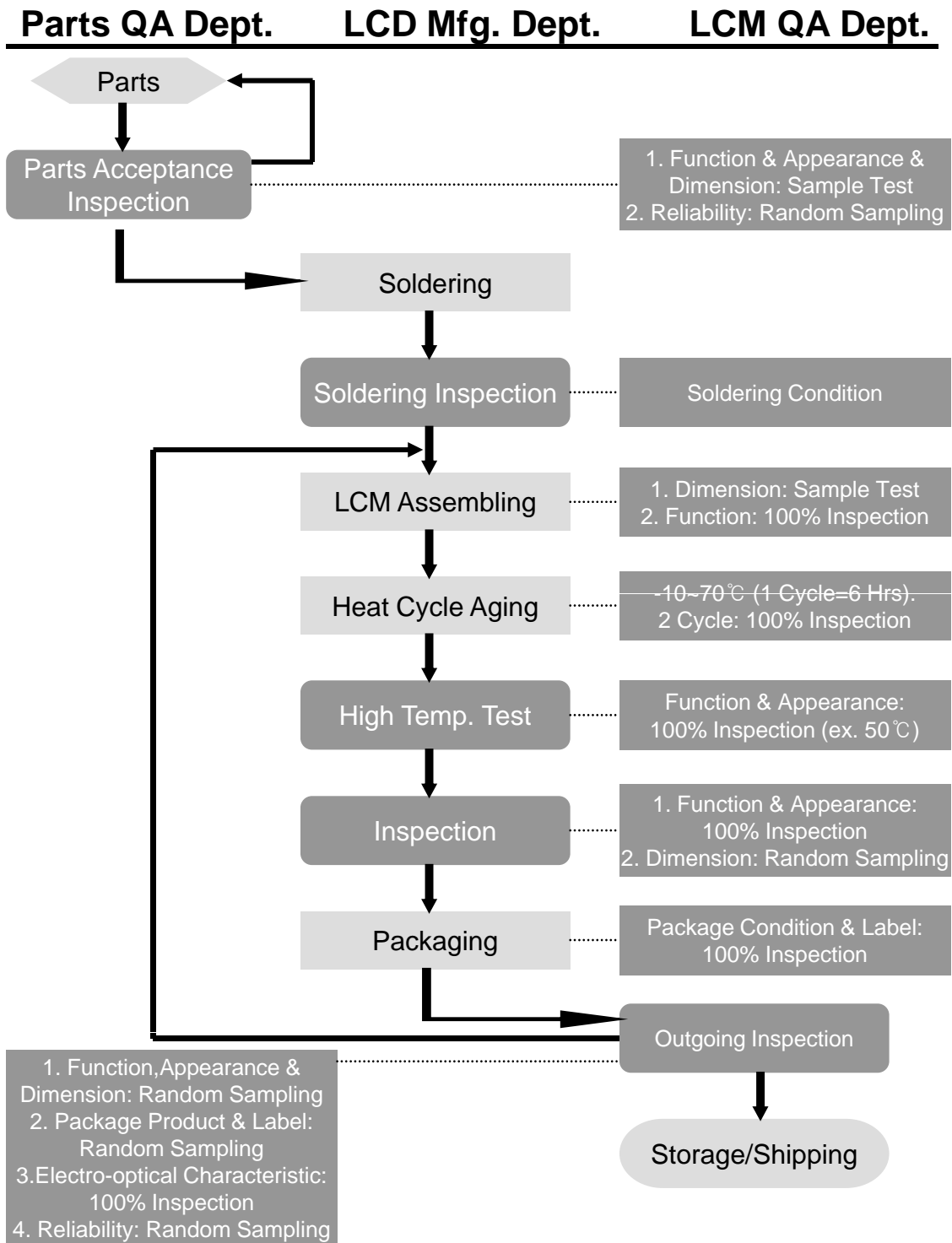

16. RELIABILITY

•Operating life time:

Longer than 50000 hours (at room temperature without direct irradiation of sunlight)

•Reliability Characteristics:

Item	Test	Criterion
High temp	70°C / 200 Hrs	■Total current consumption should be below double of initial value ■Contrast ratio should be within initial value±50% ■No defect in cosmetic and operational function is allowable
Low temp.	-20°C / 200 Hrs	
High humidity	40°C * 90%RH / 200 Hrs	
Thermal shock	-20°C→25°C→70°C→25°C /5 Cycles (30min) (5min) (30min) (5min)	
Vibration	1.Operating time: Thirty minutes exposure in each direction (x, y, z) 2.Sweep Frequency (1min):10Hz→ 55Hz →10Hz 3.Amplitude: 0.75mm double amplitude	

17. Handling Precautions

1. Limitation of Application:

Optrex products are designed for use in ordinary electronic devices such as business machines, telecommunications equipment, measurement devices and etc. Please handle the products with care. (see below)

Optrex products are not designed, intended, or authorized for use in any application which the failure of the product could result in a situation where personal injury or death may occur. these applications include, but are not limited to. life-sustaining equipment, nuclear control devices, aerospace equipment, devices related to hazardous or flammable materials, etc. [If Buyer intends to purchase or use the Optrex Products for such unintended or unauthorized applications, Buyer must secure prior written consent to such use by a responsible officer of Optrex Corporation.] Should Buyer purchase or use Optrex Products for any such unintended or unauthorized application [without such consent]. Buyer shall indemnify and hold Optrex and its officers, employees, subsidiaries, affiliates and distributors harmless against all claims, costs, damages and expenses, and reasonable attorney's fees, arising out of, directly or indirectly, any claim of personal injury or death associated with such unintended or unauthorized use, even if such claim alleges that Optrex was negligent regarding the design or manufacture of the part.

2. Industrial Rights and Patents

Optrex shall not be responsible for any infringement of industrial property rights of third parties in any country arising out of the application or use of Optrex products, except which directly concern the structure or production of such products.

No Press and Shock!

If pressure to LCD, orientation may be disturbed.
LCD will broken by shock!

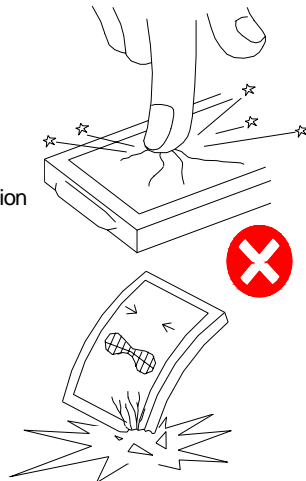

Don't Swallow or Touch Liquid Crystal!

Liquid Crystal may be leaked when display is broken.
If it accidentally gets your hands, wash then with water!

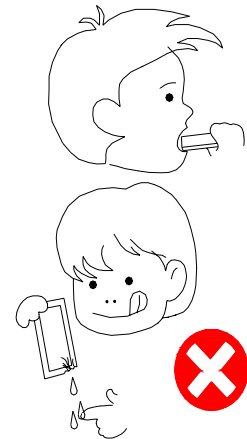

Don't not Scratch!

Polarizer is a soft material and can easily be scratched.

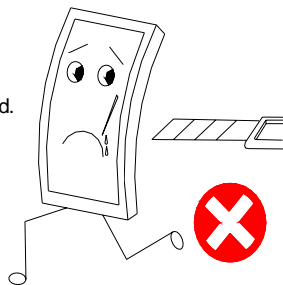

No DC Voltage to LCD!

DC voltage or driving higher than the specified voltage will reduce the lifetime of the LCD.

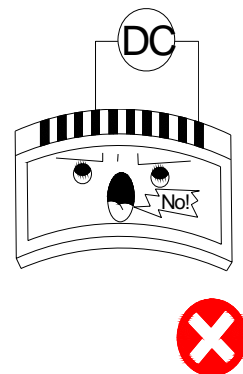

Don't Press the Metallic Frame and Disassemble the LCM

Pressure on the metallic frame and PCB may deform the conductive rubber or break the liquid crystal cell and back light, which will cause defects.

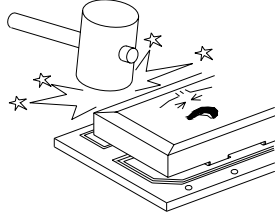

LCD may be shifted or conductive rubber may be reshaped, which will cause defects.

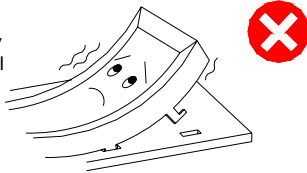

Slowly Peel Off Protective Film!

Avoid static electricity.

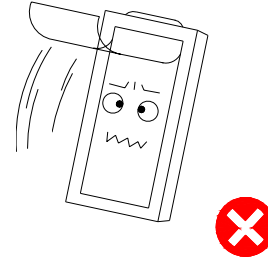

Avoid Static Electricity!

Please be sure to ground human body and electric appliances during work.

It is preferable to use conductive mat on table and wear cotton clothes or conduction processed fiber. Synthetic fiber is not recommended.

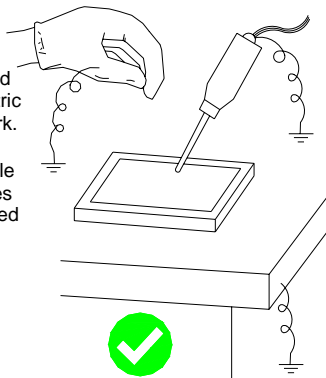

Wear Gloves While Handling!

It is preferable to wear gloves to avoid damaging the LCD.

Please do not touch electrodes with bare hands or make them dirty.

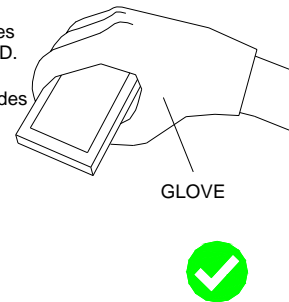

Keep Away From Extreme Heat and Humidity!

LCD deteriorates.

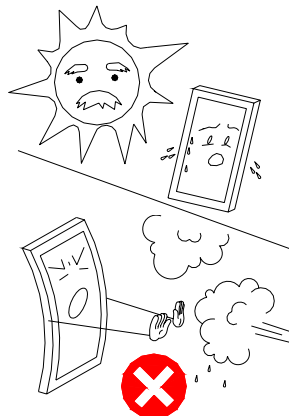

Use Alcohol to Clean Terminals!

When attaching with the heat seal or anisotropically conductive film, wipe off with alcohol before use.

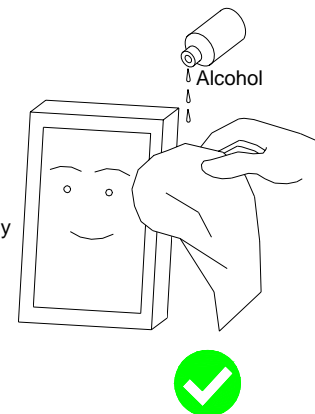

Don't Drop Water on LCD!

Note that the presence of waterdrops or dew in the LCD panel may deteriorate the polarizer or corrode electrode.

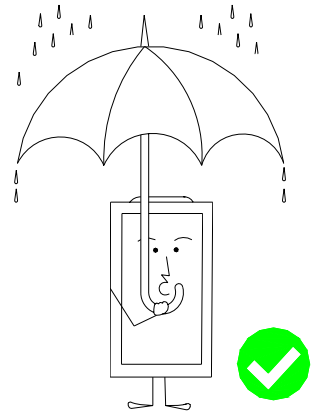
**Precaution in Soldering LCD Module**

Basic instructions: Solder I/O terminals only.
Use soldering iron without leakage.

(1) Soldering condition to I/O terminals

Temperature at tip of the iron: $280 \pm 10^{\circ}\text{C}$

Soldering time: 3~4 sec.

Type of solder: Eutectic solder (containing colophony-flux)

*Please do not use flux because it may soak into LCD Module or contaminate it.

*It is preferable to peel off protective film on display surface after soldering I/O terminals is finished.

(2) Remove connector or cable

*When you remove connector or cable soldered to I/O terminals, please confirm that solder is fully melted. If you remove by force, electrodes at I/O terminals may be damaged (or stripped off).

*It is recommended to use solder suction machine.

Long-term Storage

If it is necessary to store LCD modules for a long time, please comply with the following procedures.

If storage condition is not satisfactory, display (especially polarizer) may be deteriorated or soldering I/O terminals may become difficult (some oxide is generated at I/O terminals plating).

1. Store as delivered by Optrex

2. If you store as unpacked, put in anti-static bag, seal its opening and store where it is not subjected to direct sunshine nor fluorescent lamp.

3. Store at temperature 0 to $+35^{\circ}\text{C}$ and at low humidity. Please refer to our specification sheets for storage temperature range and humidity condition.

Long-term Storage

Please use power supply with built-in surge protection circuit.