

SPECIFICATION OF LCD MODULE

CUSTOMER 客户名称	
PART NO. 产品型号	OTM 854 B-W-1
PRODUCTS TYPE 产品内容	
REMARKS 备注	
SIGNATURE BY CUSTOMER 客户签署：	

		
---	---	---

LCM System

1 LCD Type

 S - STN

 F - FSTN

 D - DFSTN

2 Viewing Angle

 D - Lower 6:00

 U - Upper 12:00

 O - Others

3 Display Mode

 Yellow Green positive

 Blue negative

 Grey positive

 FSTN positive

 W - FSTN negative

4 Polarizer Mode

 Reflective

 Transflective

 Transmissive

5 Connector

 Pin

 Heat sealed

 Zebra

6 Thickness of Glass

 1.1mm

 0.4mm

 0.55mm

 0.7mm

7 Backlight Mode:

 LED

 CCFL

8 Backlight Color

 Blue

 Amber

 Yellow Green

 Red

 White

 Without backlight

9 Temperature Grade

 Normal temperature

 Wide temperature

 Super wide temperature

10 CG-ROM

 01 for English + Japanese Language

•REVISION RECORD

REV. NO.	REV. DATE	DESCRIPTION OF REVISION	PAGE	REMARK
1.0	16/09/08	INITIAL RELEASE	ALL	

CONTENTS

1.	FEATURES	5
2.	MECHANICAL DATA	5
3.	ABSOLUTE MAXIMUM RATING	6
4.	ELECTRICAL CHARACTERISTICS	8
5.	ELECTRO-OPTICAL CHARACTERISTICS	10
6.	BLOCK DIAGRAM	11
7.	POWER SUPPLY	11
8.	TIMIING DIAGRAM	12
9.	AC CHARACTERISTICS.....	13
10.	INITIALIZATION SEQUENCE	14
11.	INSTRUCTION SET	15
12.	FONT TABLE.....	16
13.	QUALITY ASSURANCE.....	17
14.	OUTLINE DRAWING	21
15.	INTERFACE	22
16.	PACKAGE INFORMATION.....	23
17.	QC/QA PROCEDURE	24
18.	HANDING PRECAUTIONS.....	25

1. FEATURES

Display construction	20 Characters * 4 Lines
Display mode	STN(BLUE)
Display type	Negative Transmissive
Backlight	LED(White) / 4.2V
Viewing direction	6 o'clock
Operating temperature	-20 to 70°C
Storage temperature	-30 to 80°C
Controller	SPLC780D-01 or Equivalence
Driving voltage	Single power
Driving method	1/16 duty, 1/5 bias
Type	COB (Chip On Board)
Number of data line	4/8-bit parallel
Connector	PIN

2. MECHANICAL DATA

ITEM		WIDTH	HEIGHT	THICKNES S	UNIT
Module size		98.0	60.0	14.0(MAX)	mm
Viewing area		76.0	25.2	-	mm
character	Construction	5*7			dots
	Size	2.95	4.75	-	mm
	Pitch	3.55	5.35	-	mm
Dot	Size	0.55	0.55	-	mm
	Pitch	0.60	0.60	-	mm
Diameter of mounting hole		Φ2.5			mm
Weight		About 100			g

3. ABSOLUTE MAXIMUM RATINGS

3.1 Electrical Absolute Maximum Rating

(TA = 25 , Vss=0V)

Item	Symbol	MIN.	Max.	Unit
Supply Voltage (Logic)	VDD-VSS	0	7.0	V
Supply Voltage (LCD Driver)	V _{LCD}	VDD-12	VDD+0.3	V
Input Voltage	V _{IN}	-0.3	VDD+0.3	V
Operating temperature	Top	-20	70	°C
Storage temperature	Tsto	-30	80	°C

3.2 Environmental Absolute Maximum Rating

Item	Operating		Storage		Comment
	Min.	Max.	Min.	Max.	
Ambient temp	-20	+70	-30	+80	Note(1)
Humidity	Note(2)		Note(2)		Without condensation
Vibration	--	4.9M/S ²	--	19.6M/S ²	XYZ direction
Shock	--	29.4M/S ²	--	490M/S ²	XYX direction

Note(1) Ta=0°C : 50 Hr Max.

Note(2) Ta≤40°C : 90%RH Max.

Ta≥40°C : Abslue humidity must be lower than the humidity of 90%RH@40°C

3.3 Electronic Static Discharge Maximum Rating

ESD Test Method : IEC-1000-4-2

Item	Description	
Testing environment	Ambient temperature : 15°C to 35°C Humidity : 30% to 60% LCM(E.U.T) : Power up	
Testing equipment	Manufacture : Noiseken, Model No. ESD	
Testing condition	See drawing 1	
Direct discharge	0 to ± 4KV	Discharge point, see drawing2
Indirect discharge	0 to ± 8KV	Discharge point, see drawing1
Pass condition	No malfunction of unit. Temporary malfunction of unit which can be recovered by system reset.	
Fail condition	Non. Recoverable malfunction of LCM or system.	

FIG1 ESD Testing Equipment

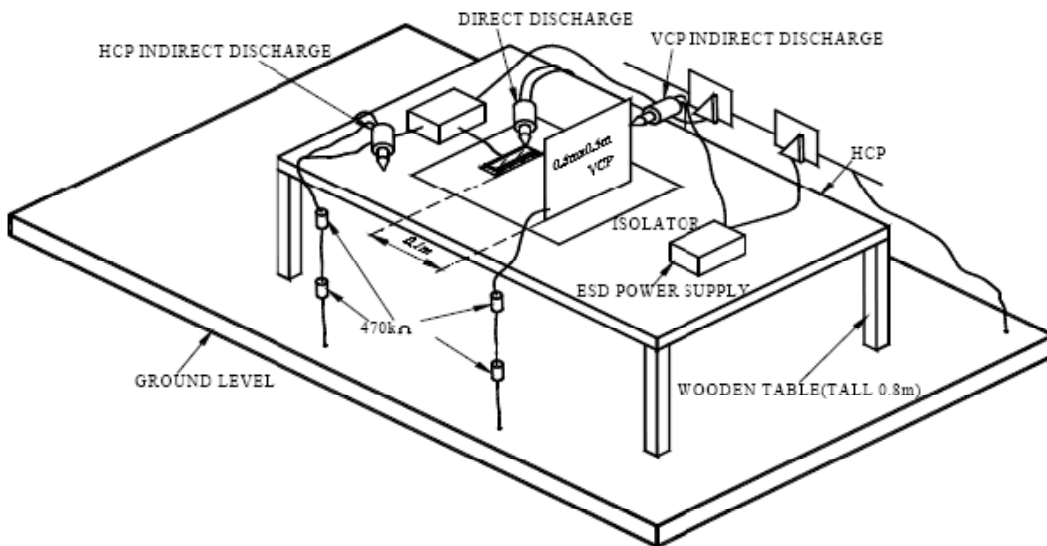

Direct Contact Discharge / Contact Point : A,B,C,D

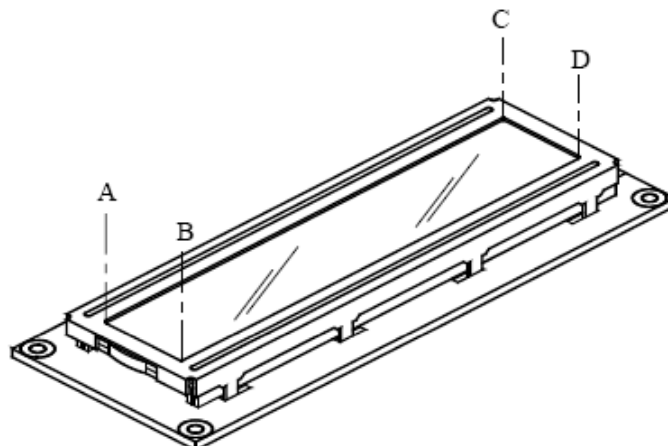

4. ELECTRICAL CHARACTERISTICS

(VDD = 4.5 to 5.5V , TA = 25)

Characteristic	Symbol	Condition	Min	Typ	Max	Unit
Operating Voltage	V_{DD}	-	4.5	-	5.5	V
Operating Current	I_{DD}	Internal oscillation or external clock ($V_{DD} = 5.0V$, $f_{osc} = 270kHz$)	-	0.35	0.6	mA
Input Voltage (1) (except OSC1)	V_{IH1}	-	2.2	-	V_{DD}	V
	V_{IL1}	-	-0.3	-	0.6	
Input Voltage (2) (OSC1)	V_{IH2}	-	$V_{DD}-1.0$	-	V_{DD}	V
	V_{IL2}	-	-0.2	-	1.0	
Output Voltage (1) (DB0 to DB7)	V_{OH1}	$I_{OH} = -0.205mA$	2.4	-	-	V
	V_{OL1}	$I_{OL} = 1.2mA$	-	-	0.4	
Output Voltage (2) (except DB0 to DB7)	V_{OH2}	$I_O = -40\mu A$	$0.9V_{DD}$	-	-	V
	V_{OL2}	$I_O = 40\mu A$	-	-	$0.1V_{DD}$	
Voltage Drop	V_{dCOM}	$I_O = \pm 0.1mA$	-	-	1	V
	V_{dSEG}		-	-	1	
Input Leakage Current	I_{LKG}	$V_{IN} = 0V$ to V_{DD}	-1	-	1	μA
Input Low Current	I_{IL}	$V_{IN} = 0V$, $V_{DD} = 5V$ (pull up)	-50	-125	-250	
Internal Clock (external Rf)	f_{OSC1}	$R_f = 91k\Omega \pm 2\%$ ($V_{DD} = 5V$)	190	270	350	kHz
External Clock	f_{OSC}	-	125	270	350	kHz
	duty		45	50	55	%
	t_R, t_F		-	-	0.2	μA
LCD Driving Voltage	V_{LCD}	$V_{DD}-V_5$ (1/5, 1/4 bias)	3.0	-	13.0	V

4.1 LED ELECTRICAL/OPTICAL CHARACTERISTICS

Item	Symbol	min	typ	max	Unit	Condition
Forward Voltage	V _f	4.8	5.0	5.2	V	I _f = 120 mA
Reverse Current	I _r		120		uA	V _r =5V
Dominant wave length	λ _p	-	-	-	nm	I _f = mA
Luminance	L _v	200	250	-	cd/m ²	I _f = 120 mA
Chromaticity Coordinates	X Y	-	0.29 0.30	-	-	I _f = 120 mA

4.2 LED ABSOLUTE MAXIMUM RATINGS

Item	Symbol	Condition	Rating	Unit
Reverse Voltage	V _r	T _a =25°C	5	V
Absolute maximum forward current	I _{fm}	T _a =25°C	160	mA
Power description	pd	T _a =25°C	800	mW

4.2.1 LED ARRAY BLOCK DIAGRAM

(LED DICE = 4 dices)

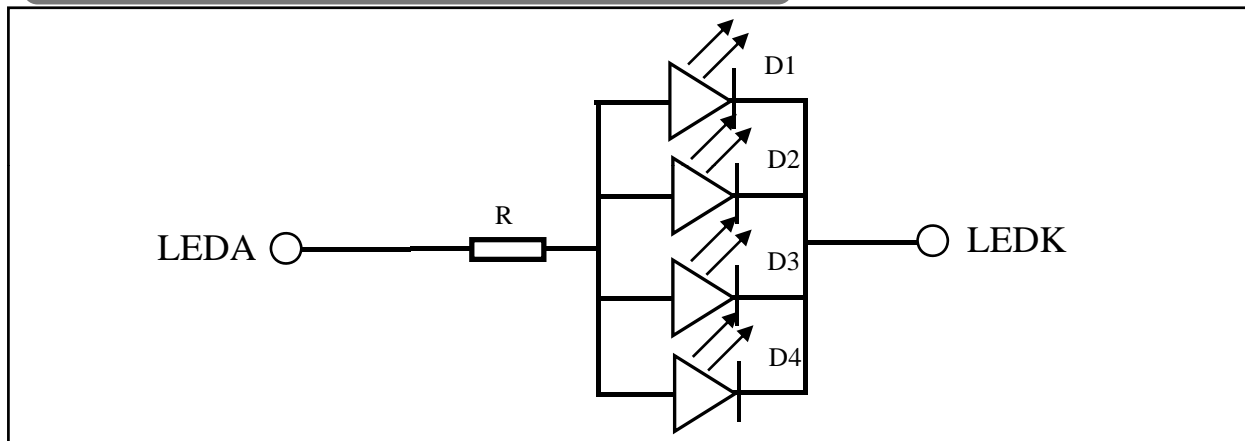

4.2.2 LED POWER SOURCE

LED	Option	Power source	Jumper setting
LED	A	15A/16K	R9、R11-R13
	B	15K/16A	R8、R10、R12、R13
	C	VDD/VSS	R12-R15
GND	FRM GND		R16

5. ELECTRO-OPTICAL CHARACTERISTICS

ITEM	SYMBOL	CONDITION	MIN.	TYP.	MAX.	UNIT	NOTE
Contrast ratio	K	$\varphi=0$	1.4	4	-	-	1
Response time (rise)	T_r	$\varphi=1$	-	130	-	ms	2
Response time (fall)	T_f	$\varphi=2$	-	130	-	ms	2
Viewing angle	φ	$K \geq 1.4$	-40 -- +10			deg.	3
	θ		-30 -- +30				

Note 1: Definition of Contrast Ratio "K"

$$K = \frac{\text{Brightness of non-selected segment(A)}}{\text{Brightness of selected segment(B)}}$$

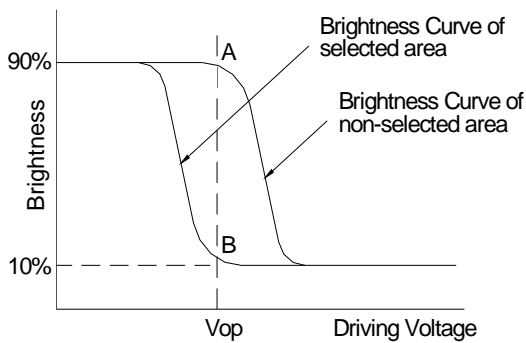

Note 2: Definition of Optical Response Time

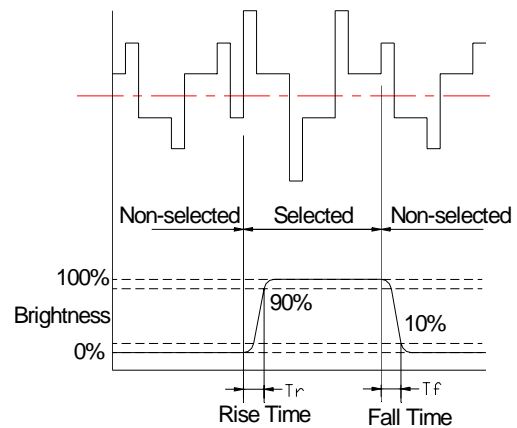

Note 3: Definition of Viewing Angle

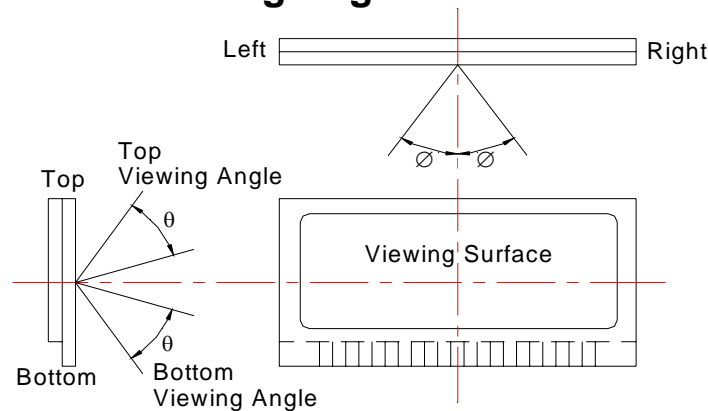

Please select either top or bottom viewing angle

6. BLOCK DIAGRAM

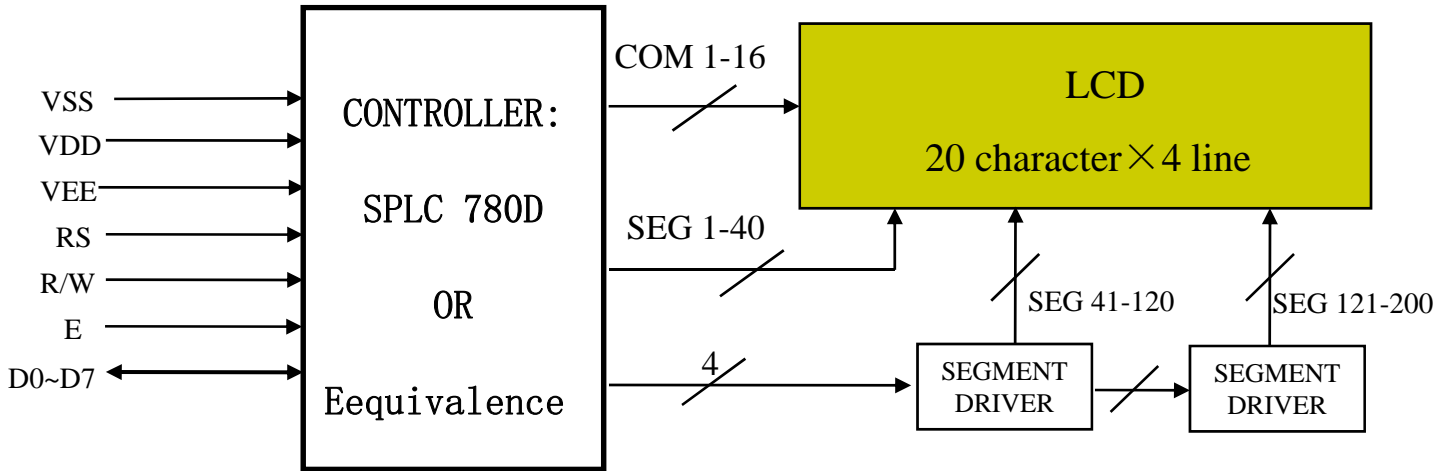

7. POWER SUPPLY

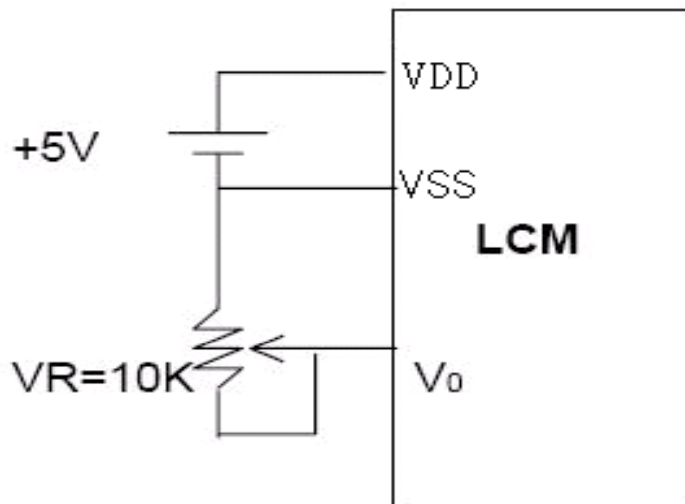

8. TIMING DIAGRAM

• WRITE OPERATION

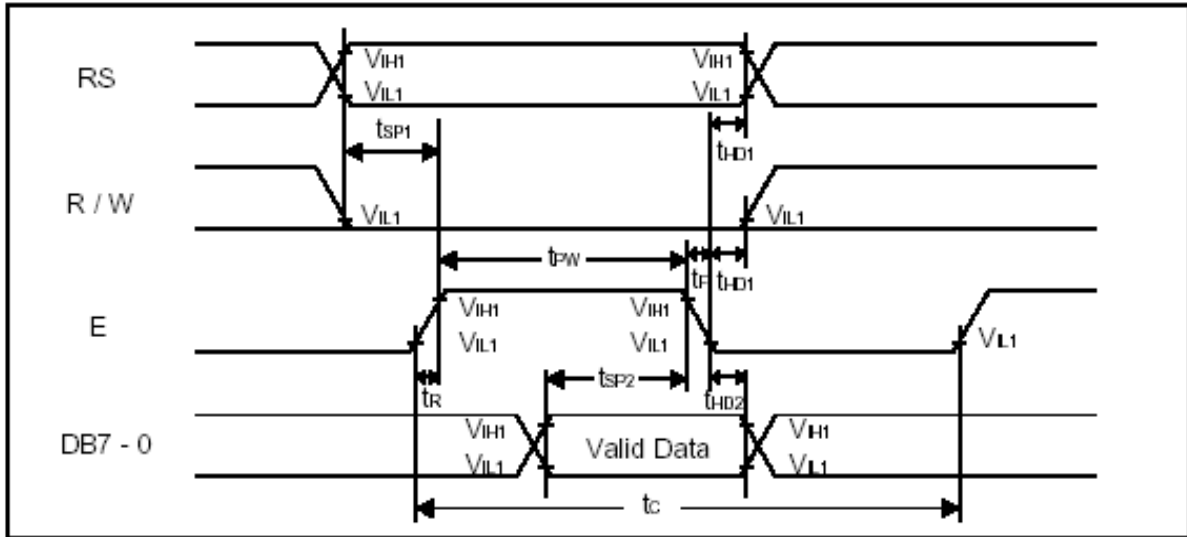

• READ OPERATION

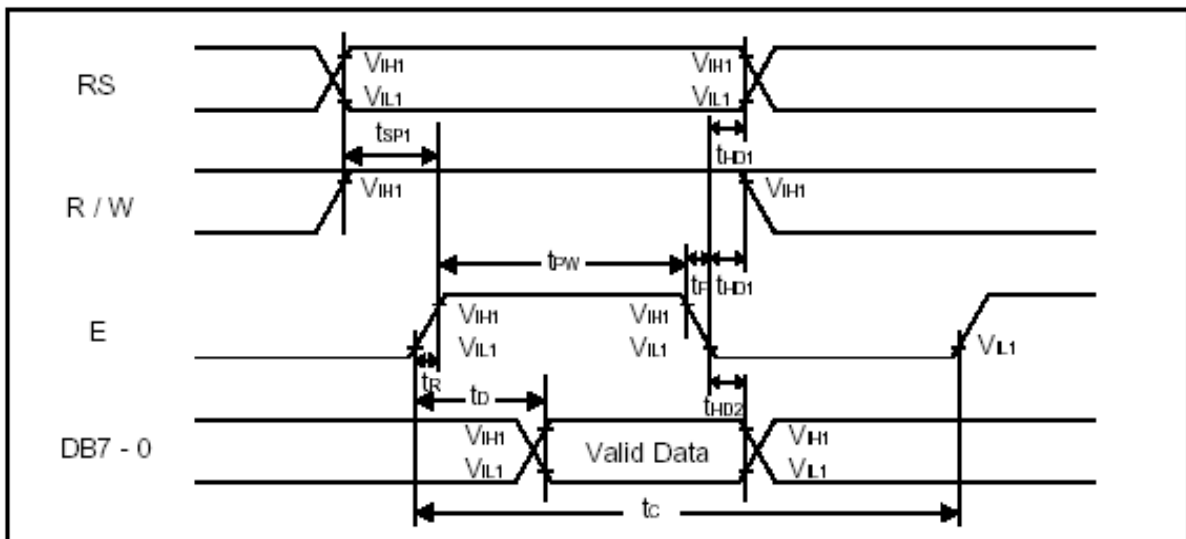

9. AC CHARACTERISTICS

• WRITE MODE

Characteristics	Symbol	Limit			Unit	Test Condition
		Min.	Typ.	Max.		
E Cycle Time	t_c	1000	-	-	ns	Pin E
E Pulse Width	t_{pw}	450	-	-	ns	Pin E
E Rise/Fall Time	t_R, t_F	-	-	25	ns	Pin E
Address Setup Time	t_{SP1}	60	-	-	ns	Pins: RS, R/W, E
Address Hold Time	t_{HD1}	20	-	-	ns	Pins: RS, R/W, E
Data Setup Time	t_{SP2}	195	-	-	ns	Pins: DB7 - 0
Data Hold Time	t_{HD2}	10	-	-	ns	Pins: DB7 - 0

• READ MODE

Characteristics	Symbol	Limit			Unit	Test Condition
		Min.	Typ.	Max.		
E Cycle Time	t_c	1000	-	-	ns	Pin E
E Pulse Width	t_w	450	-	-	ns	Pin E
E Rise/Fall Time	t_R, t_F	-	-	25	ns	Pin E
Address Setup Time	t_{SP1}	60	-	-	ns	Pins: RS, R/W, E
Address Hold Time	t_{HD1}	20	-	-	ns	Pins: RS, R/W, E
Data Output Delay Time	t_D	-	-	360	ns	Pins: DB7 - 0
Data hold time	t_{HD2}	5.0	-	-	ns	Pin DB7 - 0

10. INITIALIZATION SEQUENCE

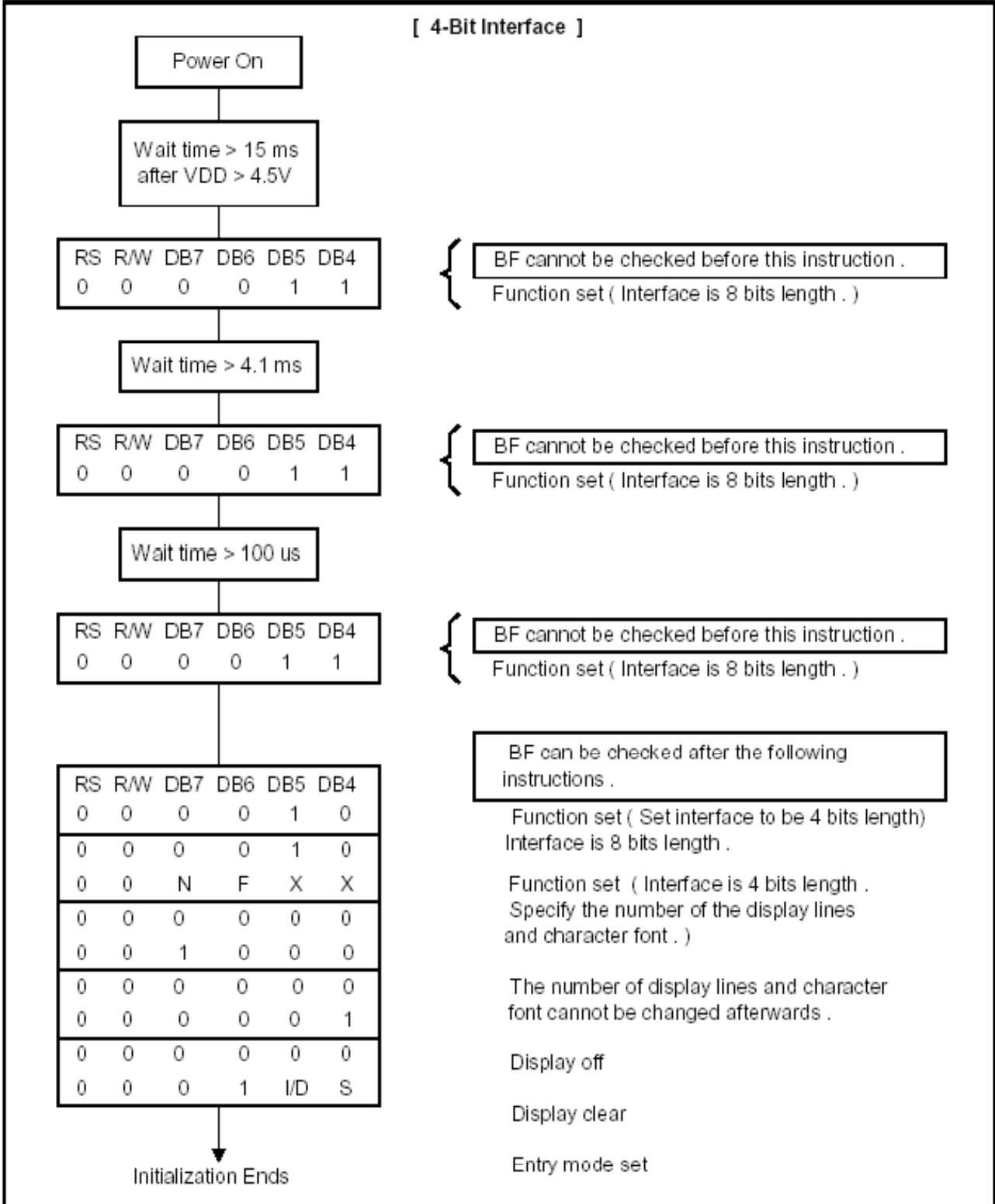

11. INSTRUCTION SET

COMMAND	COMMAND CODE										COMMAND CODE	E-CYCLE $f_{osc}=250\text{KHz}$
	RS	R/W	DB7	DB6	DB5	DB4	DB3	DB2	DB1	DB0		
SCREEN CLEAR	0	0	0	0	0	0	0	0	0	1	Screen Clear, Set AC to 0 Cursor Reposition	1.64ms
CURSOR RETURN	0	0	0	0	0	0	0	0	1	*	DDRAM AD=0, Return, Content Changeless	1.64ms
INPUT SET	0	0	0	0	0	0	0	1	I/D	S	Set moving direction of cursor Appoint if move	40us
DISPLAY SWITCH	0	0	0	0	0	0	1	D	C	B	Set display on/off,cursor on/off, blink on/off	40us
SHIFT	0	0	0	0	0	1	S/C	R/L	*	*	Remove cursor and whole display,DDRAM changeless	40us
FUNCTION SET	0	0	0	0	1	DL	N	F	*	*	Set DL,display line,font	40us
CGRAM AD SET	0	0	0	1	ACG					Set CGRAM AD, send receive data		40us
DDRAM AD SET	0	0	1	ADD					Set DDRAM AD, send receive data		40us	
BUSY/AD READ CT	0	1	BF	AC					Executing internal function, reading AD of CT		40us	
CGRAM/ DDRAM DATA WRITE	1	0	DATA WRITE					Write data from CGRAM or DDRAM		40us		
CGRAM/ DDRAM DATA READ	1	1	DATA READ					Read data from CGRAM or DDRAM		40us		
	I/D=1: Increment Mode; I/D=0: Decrement Mode S=1: Shift S/C=1: Display Shift; S/C=0: Cursor Shift R/L=1: Right Shift; R/L=0: Left Shift DL=1: 8D DL=0: 4D N=1: 2R N=0: 1R F=1: 5x10 Style; F=0: 5x7 Style BF=1: Execute Internal Function; BF=0: Command Received										DDRAM: Display data RAM CGRAM: Character Generator RAM ACG: CGRAM AD ADD: DDRAM AD & Cursor AD AC: Address counter for DDRAM & CGRAM	E-cycle changing with main frequency. Example: If fcp or $f_{osc}=270\text{KHz}$ 40us x 250/270 =37us

12. FONT TABLE

b7- b3 b4 -b0		0000	0010	0011	0100	0101	0110	0111	1010	1011	1100	1101	1110	1111
0000	CG RAM (1)		0	a	P	`	P		—	9	3	ø	p	
0001	(2)	!	1	A	Q	a	9	9	7	7	4	ä	q	
0010	(3)	"	2	B	R	b	r	7	7	7	7	p	ø	
0011	(4)	#	3	C	S	c	s	7	7	7	7	e	ø	
0100	(5)	\$	4	D	T	d	t	7	7	7	7	4	ø	
0101	(6)	%	5	E	U	e	u	7	7	7	7	ø	ü	
0110	(7)	&	6	F	V	f	v	7	7	7	7	p	z	
0111	CG RAM (8)	'	7	G	W	g	w	7	7	7	7	g	π	
1000	CG RAM (1)	<	8	H	X	h	x	7	7	7	7	7	7	
1001	(2)	>	9	I	Y	i	y	7	7	7	7	7	7	7
1010	(3)	*	:	J	Z	j	z	7	7	7	7	7	7	7
1011	(4)	+	;	K	L	k	l	7	7	7	7	7	7	7
1100	(5)	,	<	L	*	l	l	7	7	7	7	7	7	7
1101	(6)	—	=	M	J	m	7	7	7	7	7	7	7	7
1110	(7)	.	>	N	^	n	7	7	7	7	7	7	7	7
1111	CG RAM (8)	/	?	O	_	o	7	7	7	7	7	7	7	7

13. QUALITY ASSURANCE

13.1.1 Temperature and Humidity(Ambient Temperature)

Temperature : $20 \pm 5^{\circ} \text{C}$

Humidity : $65 \pm 5\%$

13.1.2 Operation

Unless specified otherwise, test will be conducted under function state.

13.1.3 Container

Unless specified otherwise, vibration test will be conducted to the product itself without putting it in a container.

13.1.4 Test Frequency

In case of related to deterioration such as shock test.It will be conducted only once.

13.1.5 Test Method

No.	Parameter	Conditions	Regulations
1	High Temperature Operating	$70 \pm 2^{\circ} \text{C}$	Note 3
2	Low Temperature Operating	$-20 \pm 2^{\circ} \text{C}$	Note 3
3	High Temperature Storage	$80 \pm 2^{\circ} \text{C}$	Note 3
4	Low Temperature Storage	$-30 \pm 2^{\circ} \text{C}$	Note 3
5	Vibration Test (Non-operation state)	Total fixed amplitude : 1.5mm Vibration Frequency : 10 ~ 55Hz One cycle 60 seconds to 3 directions of X.Y.Z. for each 15 minutes	Note 3
6	Damp Proof Test (Non-operation state)	$40^{\circ} \text{C} \pm 2^{\circ} \text{C}$, 90~95%RH, 96h	Note 1,2
7	Shock Test (Non-operation state)	To be measured after dropping from 60cm high once concrete surface in packing state	Note 3

Note 1: Returned under normal temperature and humidity for 4 hrs.

Note 2: No dew condensation to be observed.

Note 3: No change on display and in operation under the test condition

13.2 Inspection condition

13.2.1 Inspection conditions

The LCD shall be inspected under 40W white fluorescent light.

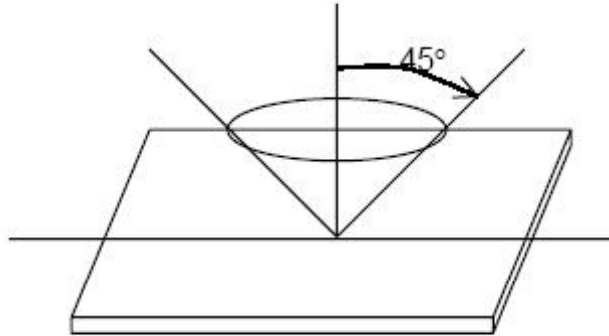

13.2.2 Definition of applicable Zones

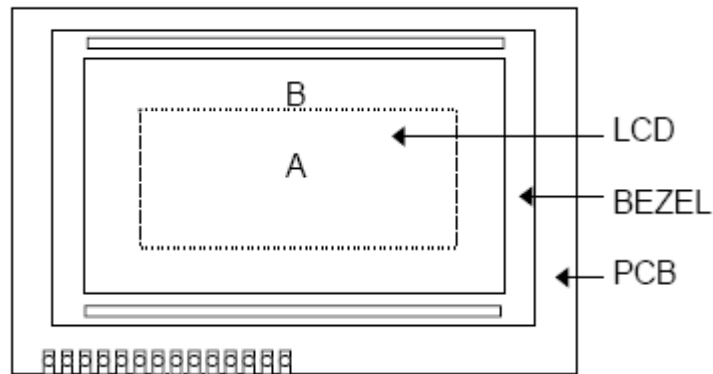

A : Display Area
B : Non-Display Area

13.2.3 Inspection Parameters

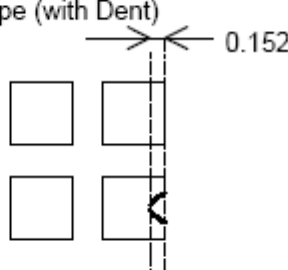
No.	Parameter	Criteria																												
1	Black or White spots	<table border="1"> <thead> <tr> <th rowspan="2">Zone Dimension</th> <th colspan="2">Acceptable number</th> <th rowspan="2">Class Of Defects</th> <th rowspan="2">AQL Level</th> </tr> <tr> <th>A</th> <th>B</th> </tr> </thead> <tbody> <tr> <td>$D < 0.15$</td> <td>*</td> <td>*</td> <td rowspan="4">Minor</td> <td rowspan="4">2.5</td> </tr> <tr> <td>$0.15 \leq D < 0.2$</td> <td>4</td> <td>4</td> </tr> <tr> <td>$0.2 \leq D \leq 0.25$</td> <td>2</td> <td>2</td> </tr> <tr> <td>$D \leq 0.3$</td> <td>0</td> <td>1</td> </tr> </tbody> </table> <p style="text-align: center;">$D = (\text{Long} + \text{Short}) / 2$ * : Disregard</p>	Zone Dimension	Acceptable number		Class Of Defects	AQL Level	A	B	$D < 0.15$	*	*	Minor	2.5	$0.15 \leq D < 0.2$	4	4	$0.2 \leq D \leq 0.25$	2	2	$D \leq 0.3$	0	1							
Zone Dimension	Acceptable number			Class Of Defects	AQL Level																									
	A	B																												
$D < 0.15$	*	*	Minor	2.5																										
$0.15 \leq D < 0.2$	4	4																												
$0.2 \leq D \leq 0.25$	2	2																												
$D \leq 0.3$	0	1																												
2	Scratch, Substances	<table border="1"> <thead> <tr> <th colspan="2">Zone</th> <th colspan="2">Acceptable number</th> <th rowspan="2">Class Of Defects</th> <th rowspan="2">AQL Level</th> </tr> <tr> <th>X (mm)</th> <th>Y (mm)</th> <th>A</th> <th>B</th> </tr> </thead> <tbody> <tr> <td>*</td> <td>$0.04 \geq W$</td> <td>*</td> <td>*</td> <td rowspan="4">Minor</td> <td rowspan="4">2.5</td> </tr> <tr> <td>$3.0 \geq L$</td> <td>$0.06 \geq W$</td> <td>4</td> <td>4</td> </tr> <tr> <td>$2.0 \geq L$</td> <td>$0.08 \geq W$</td> <td>2</td> <td>3</td> </tr> <tr> <td>—</td> <td>$0.1 < W$</td> <td>0</td> <td>1</td> </tr> </tbody> </table> <p style="text-align: center;">X : Length Y : Width * : Disregard Total defects should not exceed 4/module</p>	Zone		Acceptable number		Class Of Defects	AQL Level	X (mm)	Y (mm)	A	B	*	$0.04 \geq W$	*	*	Minor	2.5	$3.0 \geq L$	$0.06 \geq W$	4	4	$2.0 \geq L$	$0.08 \geq W$	2	3	—	$0.1 < W$	0	1
Zone		Acceptable number		Class Of Defects	AQL Level																									
X (mm)	Y (mm)	A	B																											
*	$0.04 \geq W$	*	*	Minor	2.5																									
$3.0 \geq L$	$0.06 \geq W$	4	4																											
$2.0 \geq L$	$0.08 \geq W$	2	3																											
—	$0.1 < W$	0	1																											
3	Air Bubbles (between glass & polarizer)	<table border="1"> <thead> <tr> <th rowspan="2">Zone Dimension</th> <th colspan="2">Acceptable number</th> <th rowspan="2">Class of Defects</th> <th rowspan="2">AQL Level</th> </tr> <tr> <th>A</th> <th>B</th> </tr> </thead> <tbody> <tr> <td>$D \leq 0.15$</td> <td>*</td> <td>*</td> <td rowspan="3">Minor</td> <td rowspan="3">2.5</td> </tr> <tr> <td>$0.15 < D \leq 0.25$</td> <td>2</td> <td>*</td> </tr> <tr> <td>$0.25 < D$</td> <td>0</td> <td>1</td> </tr> </tbody> </table> <p style="text-align: center;">* : Disregard Total defects shall not excess 3/module.</p>	Zone Dimension	Acceptable number		Class of Defects	AQL Level	A	B	$D \leq 0.15$	*	*	Minor	2.5	$0.15 < D \leq 0.25$	2	*	$0.25 < D$	0	1										
Zone Dimension	Acceptable number			Class of Defects	AQL Level																									
	A	B																												
$D \leq 0.15$	*	*	Minor	2.5																										
$0.15 < D \leq 0.25$	2	*																												
$0.25 < D$	0	1																												
4	Uniformity of Pixel	<p>(1) Pixel shape (with Dent)</p> 																												

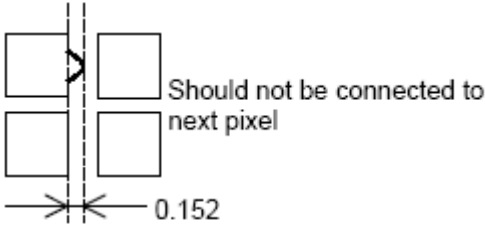
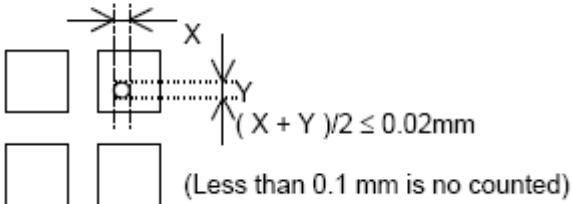
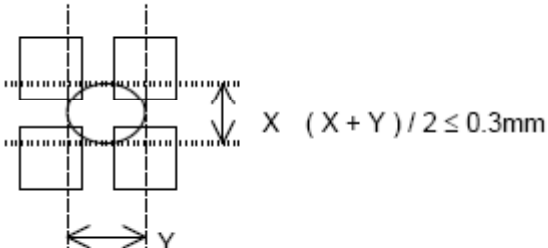
4	Uniformity of Pixel		<p>(2) Pixel shape (with Projection)</p>  <p>(3) Pin hole</p>  <p>(4) Deformation</p>  <p>Total acceptable number : 1/pixel, 5/cell</p>
	Class of defects	Major	<p>Definition</p> <p>AQL 0.65% It is a defect that is likely to result in failure or to reduce materially the usability of the product for the intended function.</p> <p>AQL 1.00% It is a defect that is likely to assembly size and not result in functioning problem.</p>
	Minor	<p>AQL 2.5% It is a defect that will not result in functioning problem with deviation classified.</p>	

14. OUTLINE DRAWING

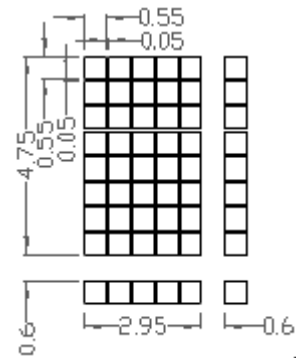
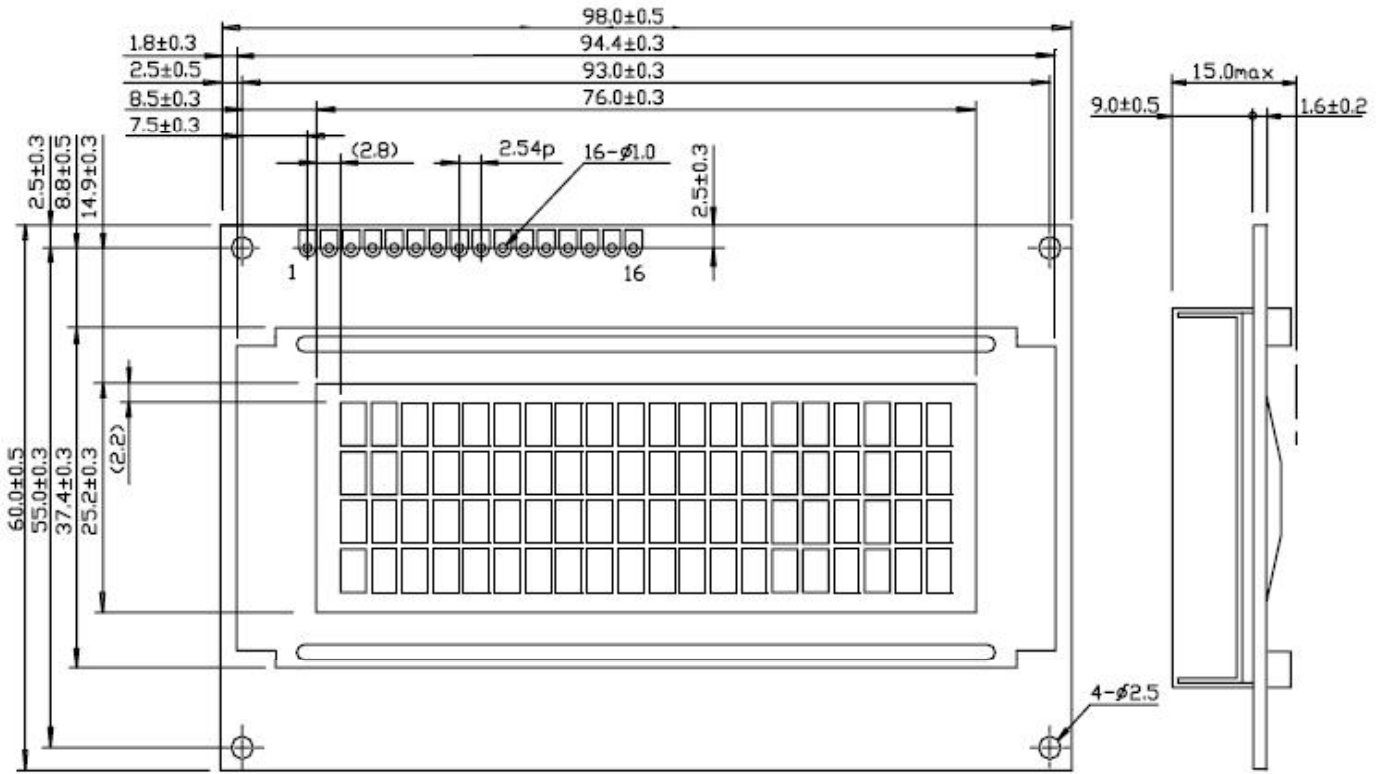

1	2	3	4	5	6	7	8
VSS	VDD	V0	RS	R/W	E	DB0	DB1
9	10	11	12	13	14	15	16
DB2	DB3	DB4	DB5	DB6	DB7	LEDA	LEDK

15. INTERFACE

PIN NO.	SYMBOL	DESCRIPTION	FUNCTION
1	VSS	GROUND	0V (GND)
2	VDD	POWER SUPPLY FOR LOGIC CIRCUIT	+5V
3	V0	LCD CONTRAST ADJUSTMENT	
4	RS	INSTRUCTION/DATA REGISTER SELECTION	RS = 0 : INSTRUCTION REGISTER RS = 1 : DATA REGISTER
5	R/W	READ/WRITE SELECTION	R/W = 0 : REGISTER WRITE R/W = 1 : REGISTER READ
6	E	ENABLE SIGNAL	
7	DB0	DATA BUS	8 BIT: DB0-DB7
8	DB1		
9	DB2		
10	DB3		
11	DB4		
12	DB5		
13	DB6		
14	DB7		
15	LEDA	SUPPLY VOLTAGE FOR LED+	+5V
16	LEDK	SUPPLY VOLTAGE FOR LED-	0V

16. PACKAGE INFORMATION

A Box include 50pcs

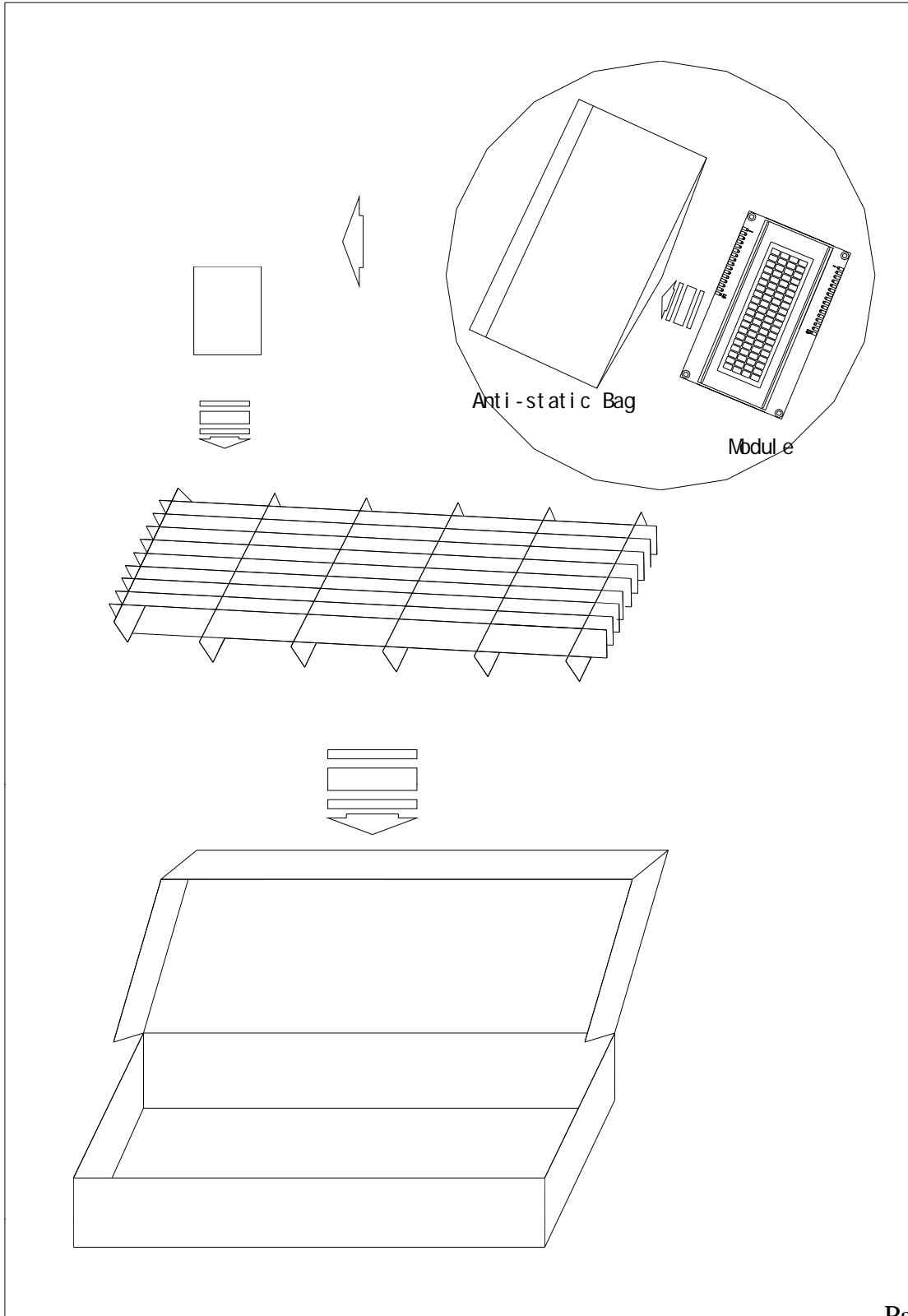

17. QC/QA PROCEDURE

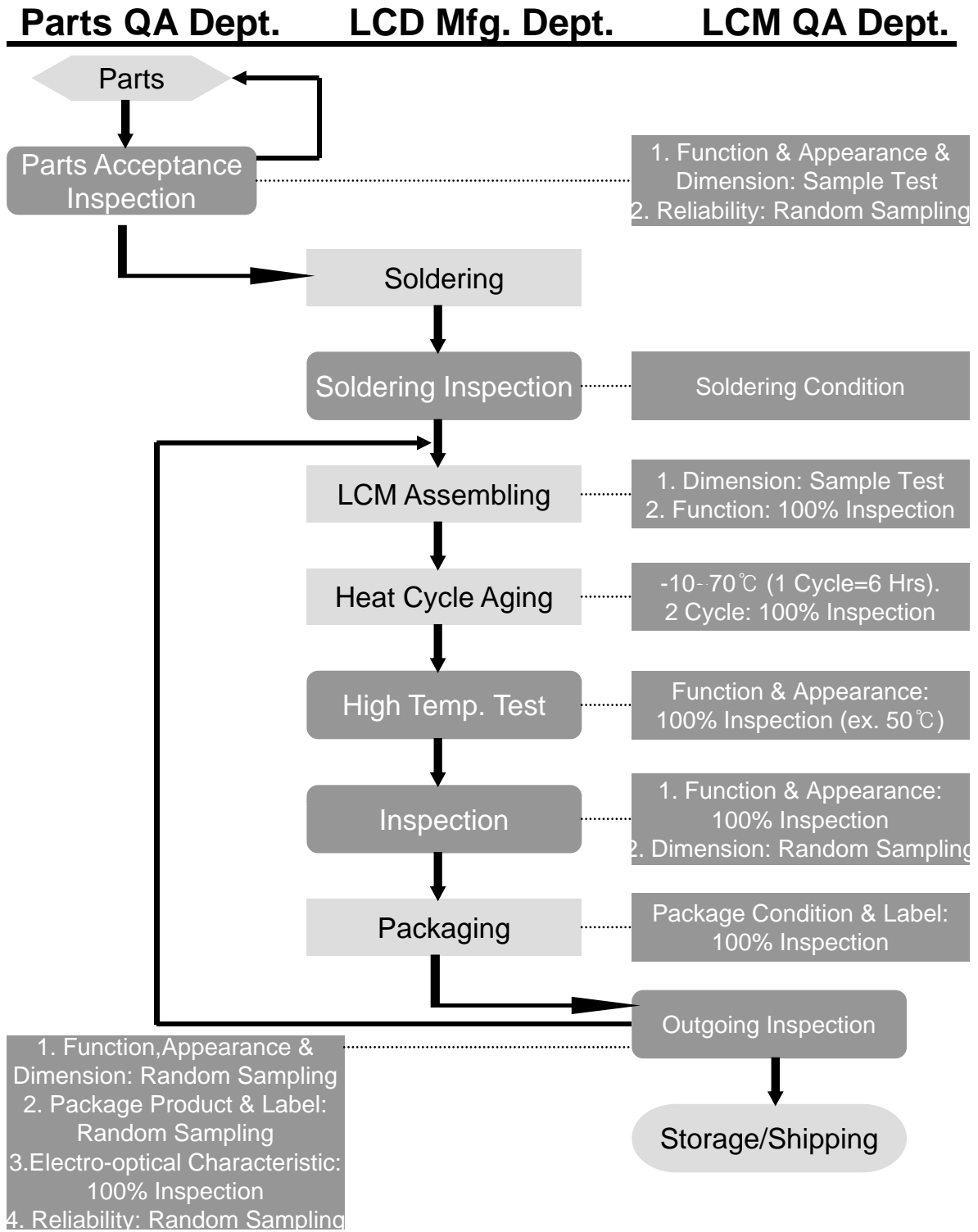

18. Handling Precautions

1. Limitation of Application:

Optrex products are designed for use in ordinary electronic devices such as business machines, telecommunications equipment, measurement devices and etc. Please handle the products with care. (see below)

Optrex products are not designed, intended, or authorized for use in any application which the failure of the product could result in a situation where personal injury or death may occur. these applications include, but are not limited to. life-sustaining equipment, nuclear control devices, aerospace equipment, devices related to hazardous or flammable materials, etc. [If Buyer intends to purchase or use the Optrex Products for such unintended or unauthorized applications, Buyer must secure prior written consent to such use by a responsible officer of Optrex Corporation.] Should Buyer purchase or use Optrex Products for any such unintended or unauthorized application [without such consent]. Buyer shall indemnify and hold Optrex and its officers, employees, subsidiaries, affiliates and distributors harmless against all claims, costs, damages and expenses, and reasonable attorney's fees, arising out of, directly or indirectly, any claim of personal injury or death associated with such unintended or unauthorized use, even if such claim alleges that Optrex was negligent regarding the design or manufacture of the part.

2. Industrial Rights and Patents

Optrex shall not be responsible for any infringement of industrial property rights of third parties in any country arising out of the application or use of Optrex products, except which directly concern the structure or production of such products.

No Press and Shock!

If pressure to LCD, orientation may be disturbed.
LCD will broken by shock!

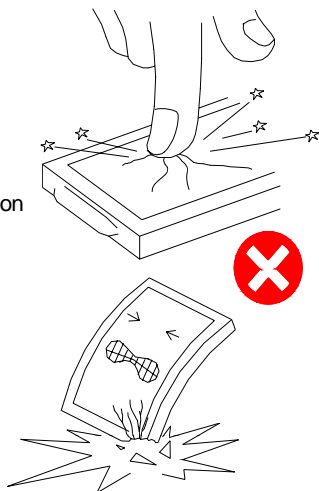

Don't Swallow or Touch Liquid Crystal!

Liquid Crystal may be leaked when display is broked.
If it accidentally gets your hands, wash then with water!

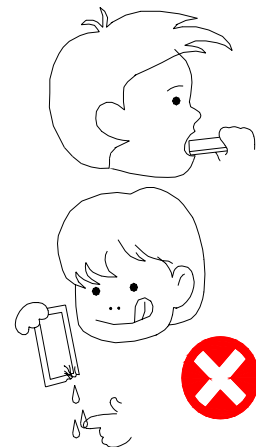

Don't not Scratch!

Polarizer is a soft material and can easily be scratched.

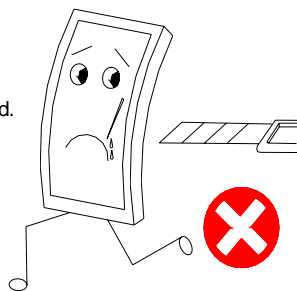

No DC Voltage to LCD!

DC voltage or driveing higher than the specified voltage will reduce the lifetime of the LCD.

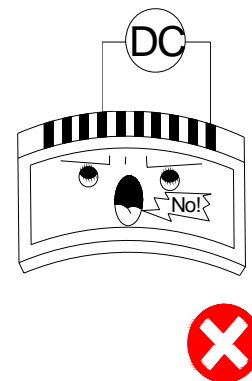

Don't Press the Metallic Frame and Disassemble the LCM

Pressure on the metallic frame and PCB may deform the conductive rubber or break the liquid crystal cell and back light, which will cause defects.

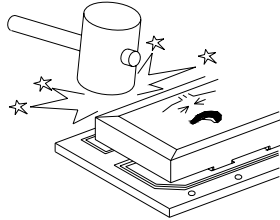

LCD may be shifted or conductive rubber may be reshaped, which will cause defects.

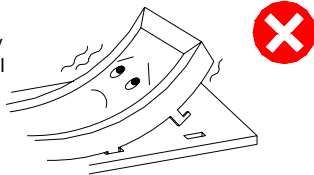

Slowly Peel Off Protective Film!

Avoid static electricity.

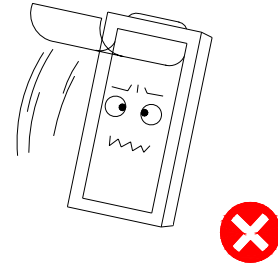

Avoid Static Electricity!

Please be sure to ground human body and electric appliances during work.

It is preferable to use conductive mat on table and wear cotton clothes or conduction processed fiber. Synthetic fiber is not recommended.

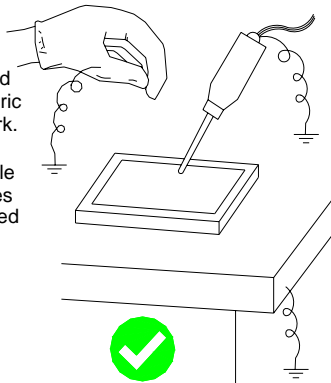

Wear Gloves While Handling!

It is preferable to wear gloves to avoid damaging the LCD.

Please do not touch electrodes with bare hands or make them dirty.

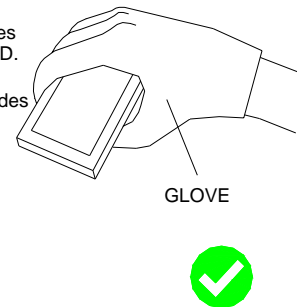

Keep Away From Extreme Heat and Humidity!

LCD deteriorates.

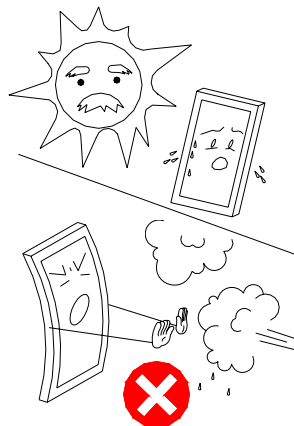

Use Alcohol to Clean Terminals!

When attaching with the heat seal or anisotropically conductive film, wipe off with alcohol before use.

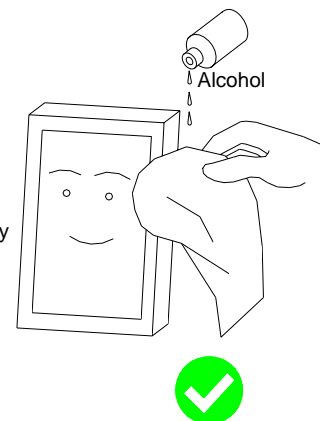

Don't Drop Water on LCD!

Note that the presence of waterdrops or dew in the LCD panel may deteriorate the polarizer or corrode electrode.

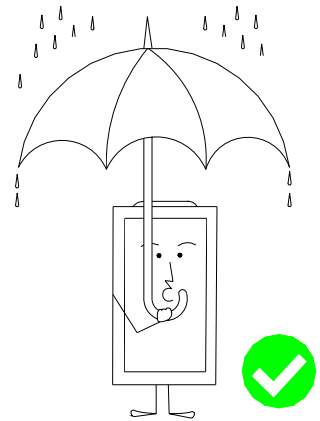
**Precaution in Soldering LCD Module**

Basic instructions: Solder I/O terminals only.
Use soldering iron without leakage.

(1) Soldering condition to I/O terminals

Temperature at tip of the iron: $280 \pm 10^\circ\text{C}$

Soldering time: 3~4 sec.

Type of solder: Eutectic solder (containing colophony-flux)

*Please do not use flux because it may soak into LCD Module or contaminate it.

*It is preferable to peel off protective film on display surface after soldering I/O terminals is finished.

(2) Remove connector or cable

*When you remove connector or cable soldered to I/O terminals, please confirm that solder is fully melted. If you remove by force, electrodes at I/O terminals may be damaged (or stripped off).

*It is recommended to use solder suction machine.

Long-term Storage

If it is necessary to store LCD modules for a long time, please comply with the following procedures.

If storage condition is not satisfactory, display (especially polarizer) may be deteriorated or soldering I/O terminals may become difficult (some oxide is generated at I/O terminals plating).

1. Store as delivered by Optrex

2. If you store as unpacked, put in anti-static bag, seal its opening and store where it is not subjected to direct sunshine nor fluorescent lamp.

3. Store at temperature 0 to $+35^\circ\text{C}$ and at low humidity. Please refer to our specification sheets for storage temperature range and humidity condition.

Long-term Storage

Please use power supply with built-in surge protection circuit.