

MECHANICAL

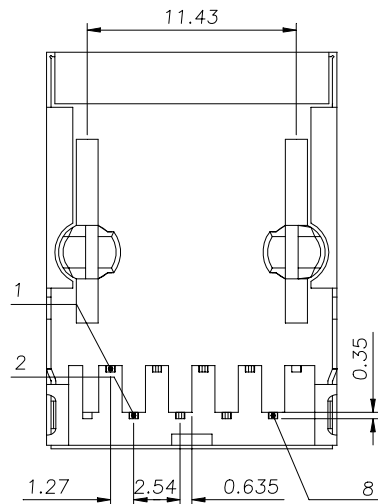
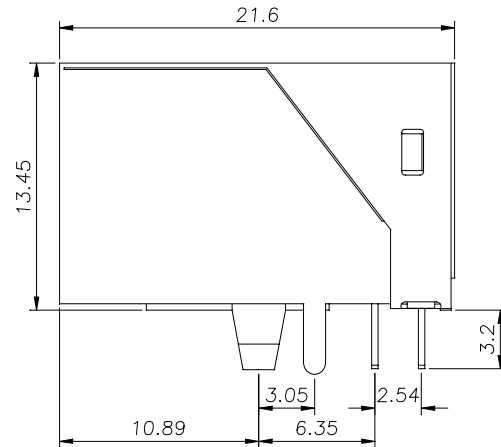
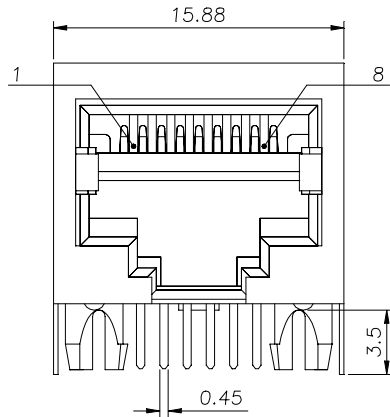

GENERAL TOLERANCE

.x ±0.38

.xx ±0.25

.xxx ±0.13

PCB LAYOUT

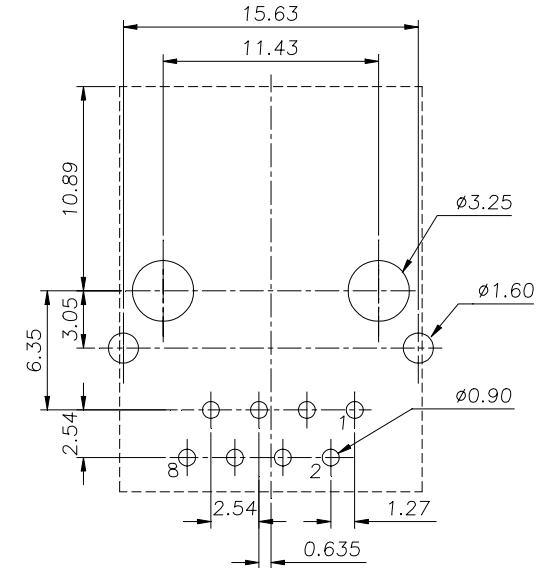

RECOMMENDED P.C.B. LAYOUT
(COMPONENT SIDE)

Housing : High Temperature Thermoplastic UL94V-0

Contact : High Strength Copper Alloys

Shell : Stainless Steel



SCHEMATIC

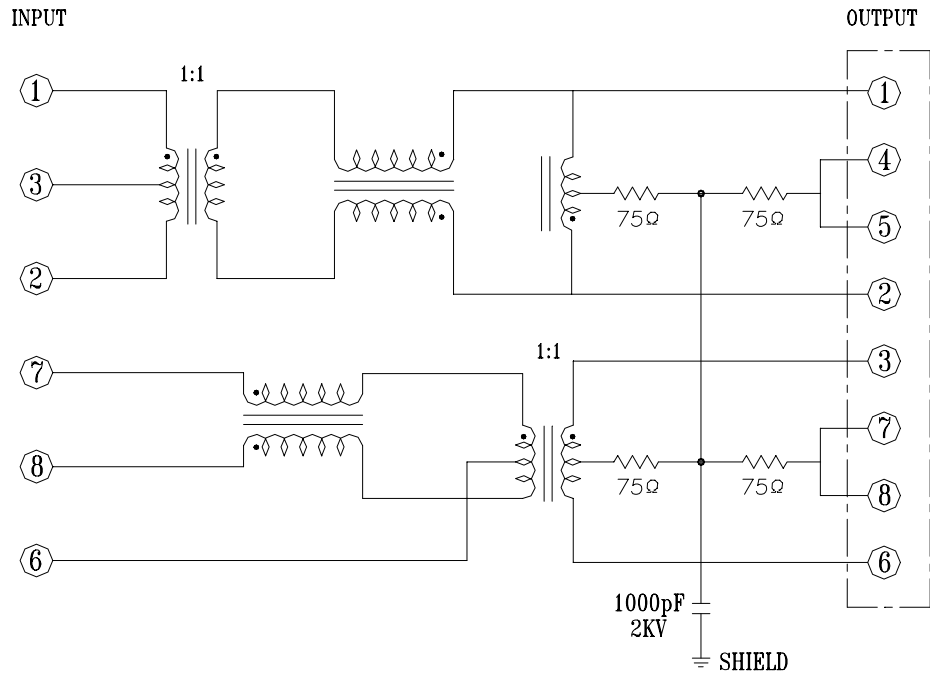

ELECTRICAL CHARACTERISTICS

Transmitter filter

Type : Balance low pass 100 OHM impedance

Insertion loss : 1-100 MHz -1.0dB MAX.

Return loss : 1-30 MHz -20dB MIN. load 100 OHM

30-60 MHz -15dB MIN. load 100 OHM

60-80 MHz -11dB MIN. load 100 OHM

Receiver filter

Type : Balance low pass 100 OHM impedance

Insertion loss : 1-100 MHz -1.0dB MAX.

Return loss : 1-30 MHz -20dB MIN. load 100 OHM

30-60 MHz -17dB MIN. load 100 OHM

60-80 MHz -15dB MIN. load 100 OHM

Common Mode Rejection

@ 1-100 MHz -30dB MIN.

Cross Talk

@ 1-100 MHz -30dB MIN.

INDUCTANCE @ 100KHz, 0.1V, 8mA DC BIAS

Input(1-2), Input(7-8) : 350 μ H MIN.

HiPot TEST

Input(1-2) to Output(1-2) : 1500VAC, 60sec

Input(7-8) to Output(3-6) : 1500VAC, 60sec