

P0306BT

N-Channel Enhancement Mode MOSFET

PRODUCT SUMMARY

$V_{(BR)DSS}$	$R_{DS(ON)}$	I_D
60V	3.4m Ω @ $V_{GS} = 10V$	162A

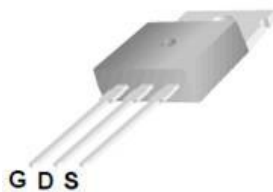

TO-220

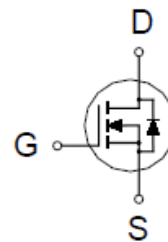

ABSOLUTE MAXIMUM RATINGS ($T_A = 25\text{ }^\circ\text{C}$ Unless Otherwise Noted)

PARAMETERS/TEST CONDITIONS		SYMBOL	LIMITS	UNITS
Gate-Source Voltage		V_{GS}	± 20	V
Continuous Drain Current ^{2,3}	$T_C = 25\text{ }^\circ\text{C}$	I_D	162	A
	$T_C = 100\text{ }^\circ\text{C}$		102	
Pulsed Drain Current ^{1,2}		I_{DM}	300	
Avalanche Current		I_{AS}	119	
Avalanche Energy	$L = 0.1\text{mH}$	E_{AS}	708	mJ
Power Dissipation	$T_C = 25\text{ }^\circ\text{C}$	P_D	178	W
	$T_C = 100\text{ }^\circ\text{C}$		71	
Operating Junction & Storage Temperature Range		T_J, T_{STG}	-55 to 150	$^\circ\text{C}$

THERMAL RESISTANCE RATINGS

THERMAL RESISTANCE	SYMBOL	TYPICAL	MAXIMUM	UNITS
Junction-to-Case	$R_{\theta JC}$		0.7	$^\circ\text{C} / \text{W}$
Junction-to-Ambient	$R_{\theta JA}$		62.5	

¹Pulse width limited by maximum junction temperature.

²Limited only by maximum temperature allowed.

³Package limitation current is 110A.

P0306BT

N-Channel Enhancement Mode MOSFET

ELECTRICAL CHARACTERISTICS (T_J = 25 °C, Unless Otherwise Noted)

PARAMETER	SYMBOL	TEST CONDITIONS	LIMITS			UNITS
			MIN	TYP	MAX	
STATIC						
Drain-Source Breakdown Voltage	V _{(BR)DSS}	V _{GS} = 0V, I _D = 250μA	60			V
Gate Threshold Voltage	V _{GS(th)}	V _{DS} = V _{GS} , I _D = 250μA	1.3	1.8	2.3	
Gate-Body Leakage	I _{GSS}	V _{DS} = 0V, V _{GS} = ±20V			±100	nA
Zero Gate Voltage Drain Current	I _{DSS}	V _{DS} = 48V, V _{GS} = 0V			1	μA
		V _{DS} = 40V, V _{GS} = 0V, T _J = 125 °C			10	
Drain-Source On-State Resistance ¹	R _{DS(ON)}	V _{GS} = 4.5V, I _D = 20A		3	4.5	mΩ
		V _{GS} = 10V, I _D = 20A		2.6	3.4	
Forward Transconductance ¹	g _{fs}	V _{DS} = 10V, I _D = 20A		80		S
DYNAMIC						
Input Capacitance	C _{iss}	V _{GS} = 0V, V _{DS} = 25V, f = 1MHz		5825		pF
Output Capacitance	C _{oss}			1162		
Reverse Transfer Capacitance	C _{rss}			385		
Gate Resistance	R _g	V _{GS} = 0V, V _{DS} = 0V, f = 1MHz		1.4		Ω
Total Gate Charge ²	Q _g (V _{GS} =10V)	V _{DS} = 30V, V _{GS} = 10V, I _D = 20A		124		nC
	Q _g (V _{GS} =4.5V)			67		
Gate-Source Charge ²	Q _{gs}			15		
Gate-Drain Charge ²	Q _{gd}			35		
Turn-On Delay Time ²	t _{d(on)}		V _{DD} = 60V, I _D ≅ 20A, V _{GS} = 10V, R _{GEN} = 6Ω		25	
Rise Time ²	t _r			65		
Turn-Off Delay Time ²	t _{d(off)}			60		
Fall Time ²	t _f			62		
SOURCE-DRAIN DIODE RATINGS AND CHARACTERISTICS (T_J = 25 °C)						
Continuous Current ³	I _S				172	A
Forward Voltage ¹	V _{SD}	I _F = 20A, V _{GS} = 0V			1.3	V
Reverse Recovery Time	t _{rr}	I _F = 20A, dI _S /dt = 100A / μS		60		nS
Reverse Recovery Charge	Q _{rr}			127		nC

¹Pulse test : Pulse Width ≤ 300 μsec, Duty Cycle ≤ 2%.

²Independent of operating temperature.

³Package limitation current is 110A.

P0306BT

N-Channel Enhancement Mode MOSFET

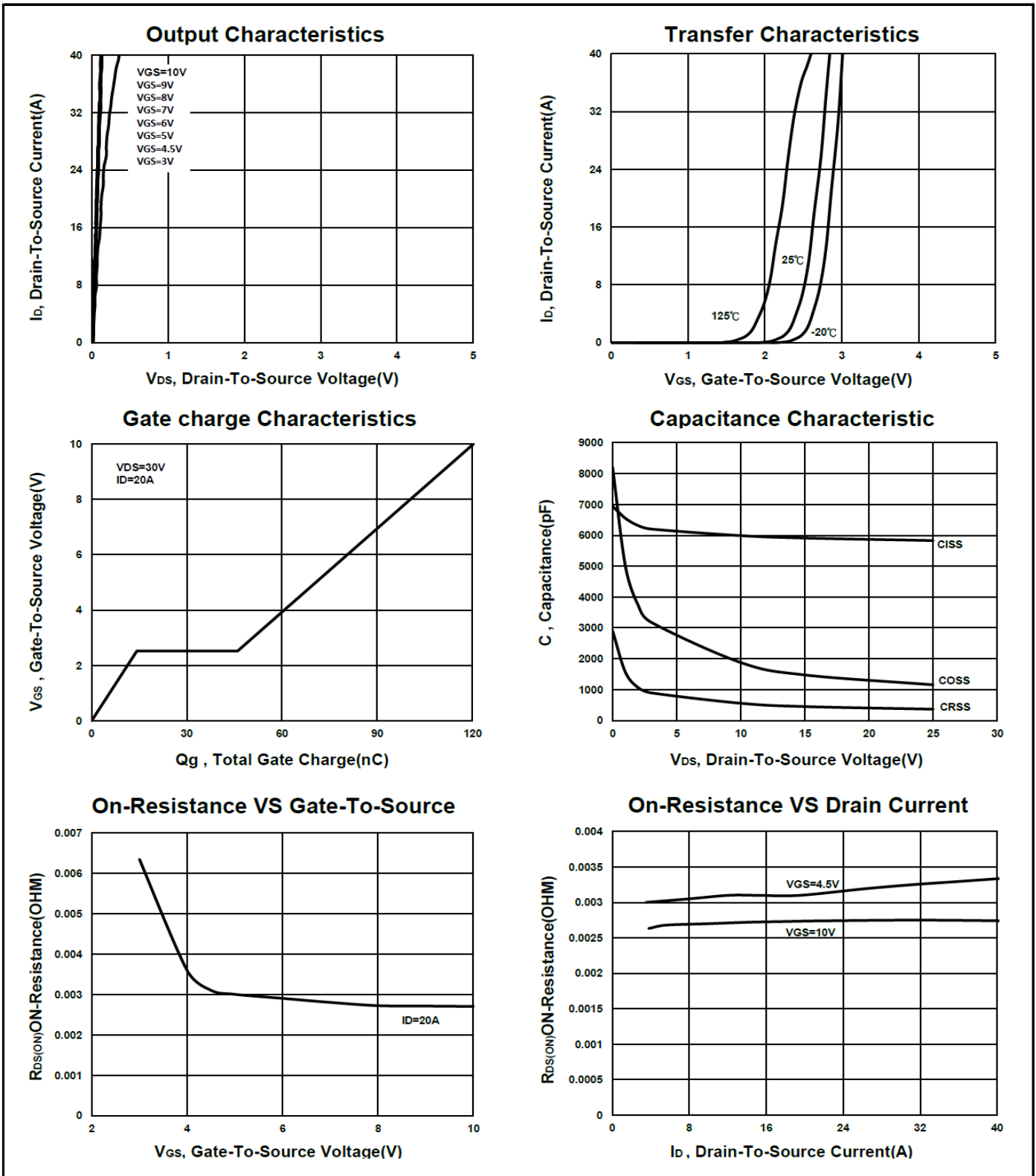

P0306BT

N-Channel Enhancement Mode MOSFET

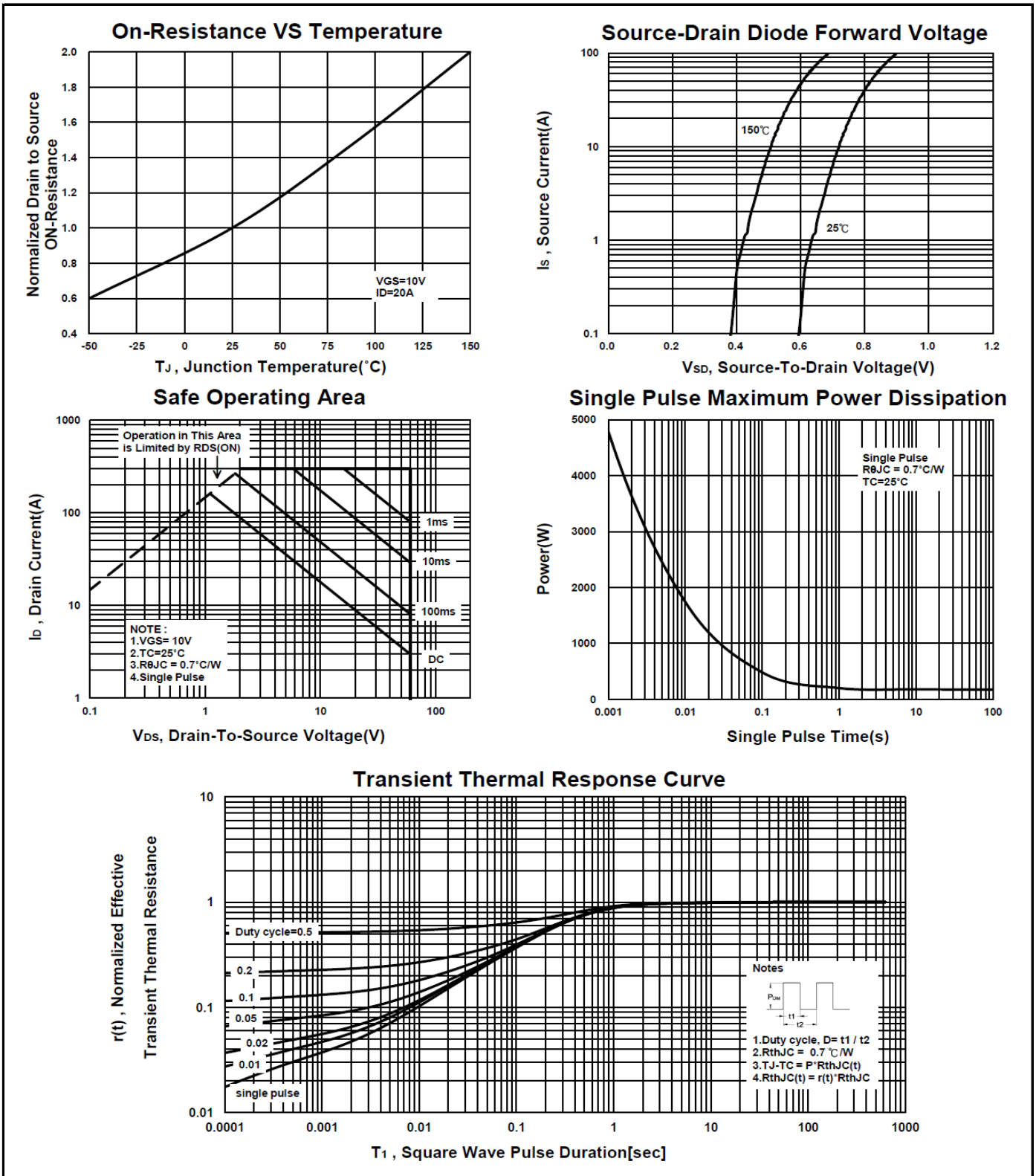

P0306BT

N-Channel Enhancement Mode MOSFET

Package Dimension

TO-220 (3-Lead) MECHANICAL DATA

Dimension	mm			Dimension	mm		
	Min.	Typ.	Max.		Min.	Typ.	Max.
A	9.65		11.5	J	3.55		4.83
B		2.54		K	1.11		1.45
C	18.1		22.86	L	1.89		3.09
D	26.9		31.24	M	0.34		0.61
E	14.32		16.51	N	2.6		4.06
F	8.38		9.3	O		3.7	
G	0.38		1.02	P	5.84		6.85
H	2.04	2.54	3.04	Q	12.5		14.73
I	1.14		1.8	R	11.3		13.31

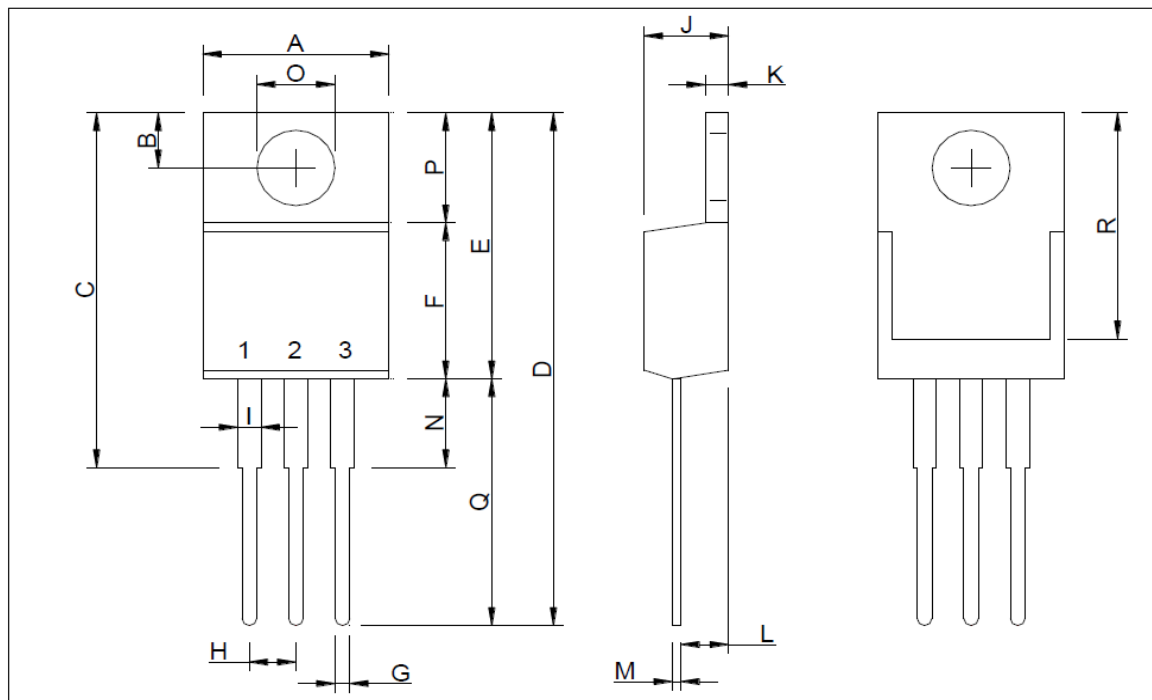

P0306BT

N-Channel Enhancement Mode MOSFET

A. Marking Information

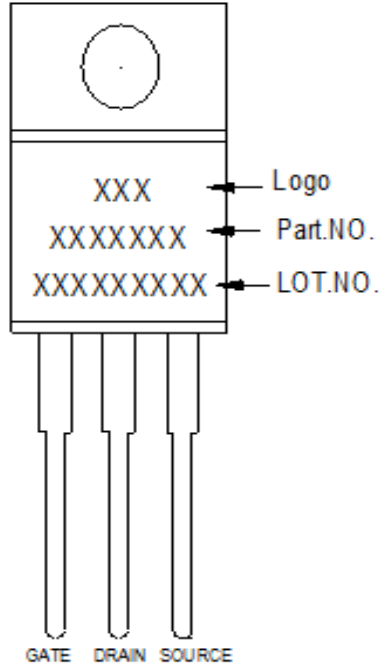

B. Tape&Reel Information:50pcs/Tube

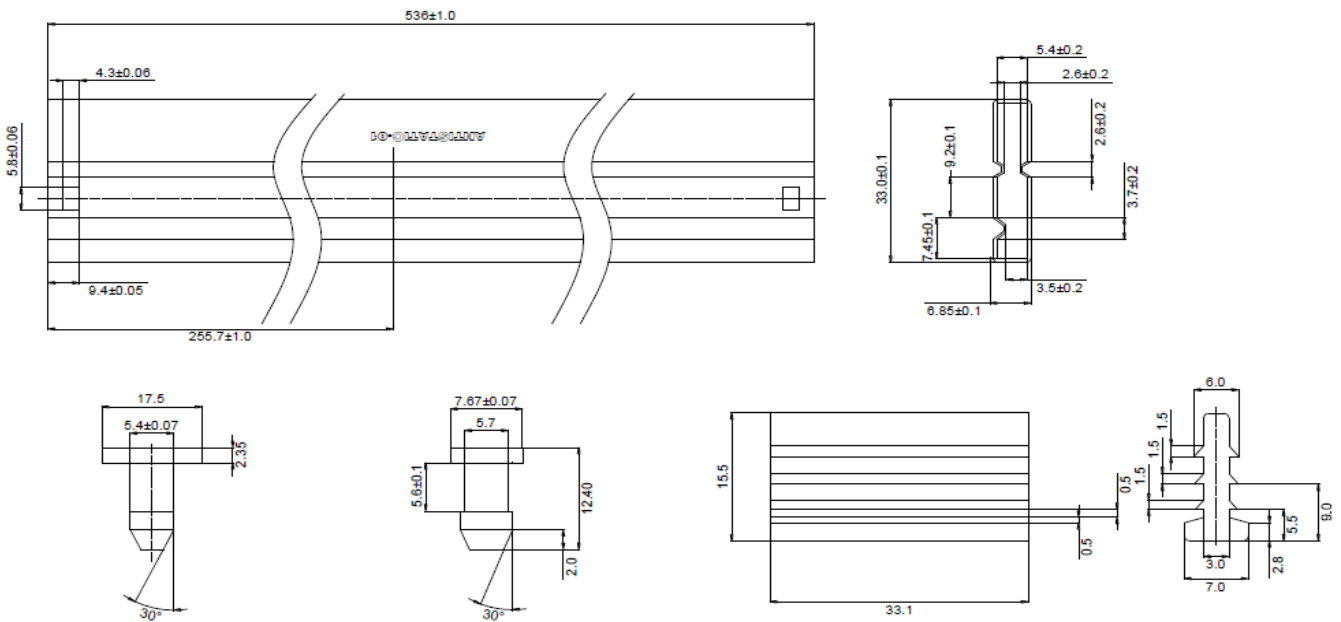

P0306BT

N-Channel Enhancement Mode MOSFET

C. Lot No.&Date Code rule

1.Lot No.

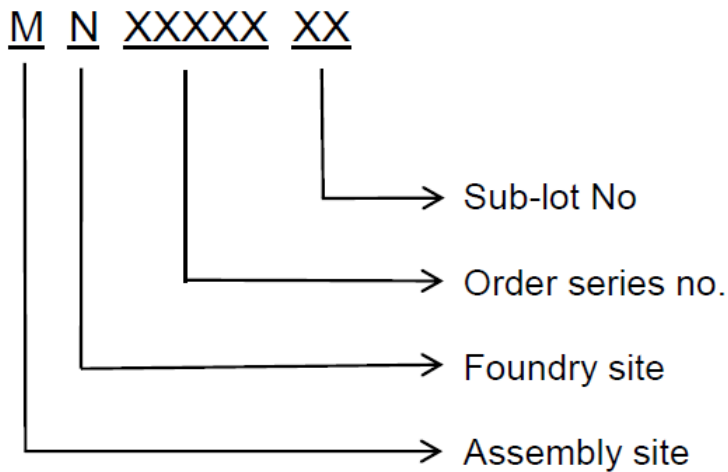

2.Date Code

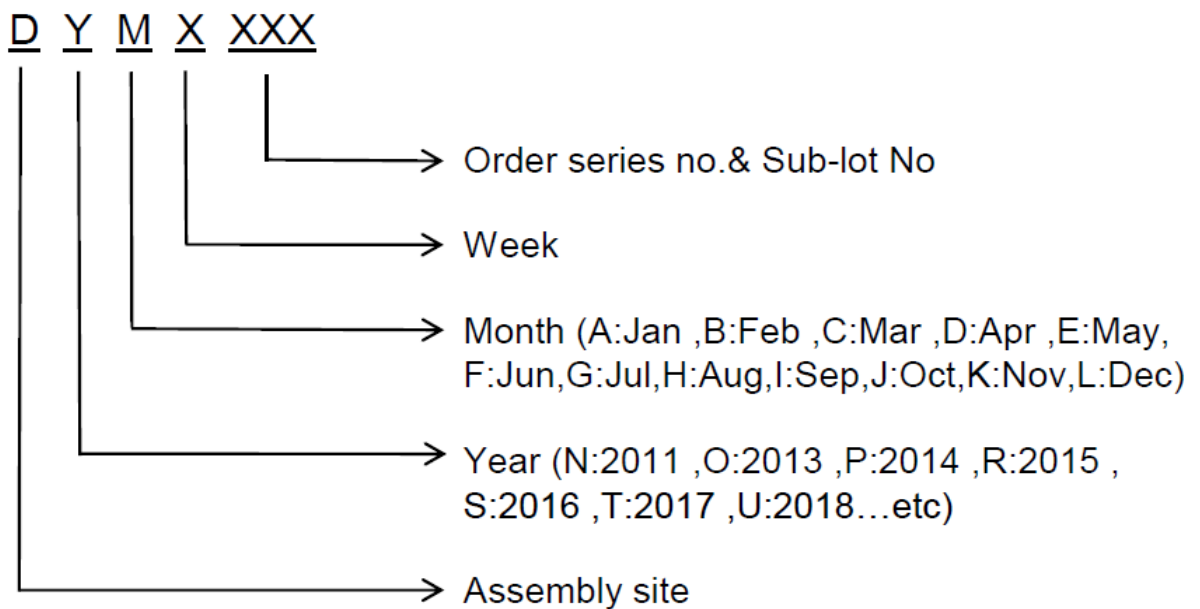



P0306BT

N-Channel Enhancement Mode MOSFET

D.Label rule

标签内容(Label content)



1	Label Size	30 * 90 mm
2	Font style	Times New Roman or Arial (或可区分英文”0”和数字”0”，”G和”Q”的字型即可)
3	U-NIKC	Height: 4 mm
4	Package	Height: 2 mm
5	Date	Height: 2 mm Shipping date: YYYY/MM/DD, ex. 2008/09/12
6	Device	Height: 3 mm (Max: 16 Digit)
7	Lot	Height: 3 mm (Max: 9 Digit) Sub lot
8	D/C	Height: 3 mm (Max: 7 Digit)
9	QTY	Height: 3 mm (Max: 6 Digit) Thousand mark is no needed
10	RoHS label	 long axis: 12 mm minor axis: 6 mm bottom color: White Font color: Black Font style: Arial
11	Halogen Free label	 Diameter: 10 mm bottom color: Green Font color: Black Font style: Arial
12	Scan information	Device / Lot / D/C / QTY , Insert “ / “ between every parts. for example: P3055LDG/G12345601/GGG2301/2000 DPI (Dots per inch): Over 300 dpi Code : Code 128 Height: 6 mm at least