

P0550EI

N-Channel Enhancement Mode MOSFET

PRODUCT SUMMARY

$V_{(BR)DSS}$	$R_{DS(ON)}$	I_D
500V	1.55Ω @ $V_{GS} = 10V$	5A

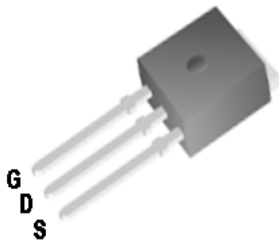

TO-251

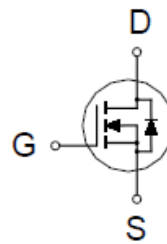

100% UIS tested

ABSOLUTE MAXIMUM RATINGS ($T_A = 25\text{ °C}$ Unless Otherwise Noted)

PARAMETERS/TEST CONDITIONS		SYMBOL	LIMITS	UNITS
Drain-Source Voltage		V_{DS}	500	V
Gate-Source Voltage		V_{GS}	±30	
Continuous Drain Current ²	$T_C = 25\text{ °C}$	I_D	5	A
	$T_C = 100\text{ °C}$		3.2	
Pulsed Drain Current ^{1,2}		I_{DM}	20	
Avalanche Current ³		I_{AS}	2.5	
Avalanche Energy ³		E_{AS}	31.2	mJ
Power Dissipation	$T_C = 25\text{ °C}$	P_D	62.5	W
	$T_C = 100\text{ °C}$		25	
Operating Junction & Storage Temperature Range		T_J, T_{STG}	-55 to 150	°C

THERMAL RESISTANCE RATINGS

THERMAL RESISTANCE	SYMBOL	TYPICAL	MAXIMUM	UNITS
Junction-to-Case	$R_{\theta JC}$		2	°C / W
Junction-to-Ambient	$R_{\theta JA}$		62.5	

¹Pulse width limited by maximum junction temperature.

²Limited only by maximum temperature allowed

³ $V_{DD} = 50V$, $L = 10mH$, starting $T_J = 25\text{ °C}$

P0550EI

N-Channel Enhancement Mode MOSFET

ELECTRICAL CHARACTERISTICS (T_J = 25 °C, Unless Otherwise Noted)

PARAMETER	SYMBOL	TEST CONDITIONS	LIMITS			UNITS
			MIN	TYP	MAX	
STATIC						
Drain-Source Breakdown Voltage	V _{(BR)DSS}	V _{GS} = 0V, I _D = 250μA	500			V
Gate Threshold Voltage	V _{GS(th)}	V _{DS} = V _{GS} , I _D = 250μA	2	3	4	
Gate-Body Leakage	I _{GSS}	V _{DS} = 0V, V _{GS} = ±30V			±100	nA
Gate Voltage Drain Current	I _{DSS}	V _{DS} = 500V, V _{GS} = 0V, T _C = 25 °C			1	μA
		V _{DS} = 400V, V _{GS} = 0V, T _C = 100 °C			10	
Drain-Source On-State Resistance ¹	R _{DS(ON)}	V _{GS} = 10V, I _D = 2.5A		1.26	1.55	Ω
Forward Transconductance ¹	g _{fs}	V _{DS} = 10V, I _D = 2.5A		6.5		S
DYNAMIC						
Input Capacitance	C _{iss}	V _{GS} = 0V, V _{DS} = 25V, f = 1MHz		565		pF
Output Capacitance	C _{oss}			68		
Reverse Transfer Capacitance	C _{rss}			10		
Total Gate Charge ²	Q _g	V _{DD} = 400V, V _{GS} = 10V, I _D = 5A		18		nC
Gate-Source Charge ²	Q _{gs}			3		
Gate-Drain Charge ²	Q _{gd}			7		
Turn-On Delay Time ²	t _{d(on)}	V _{DD} = 250V, I _D = 5A, R _G = 6Ω		30		nS
Rise Time ²	t _r			25		
Turn-Off Delay Time ²	t _{d(off)}			98		
Fall Time ²	t _f			30		
SOURCE-DRAIN DIODE RATINGS AND CHARACTERISTICS (T_J = 25 °C)						
Continuous Current ³	I _S				5	A
Forward Voltage ¹	V _{SD}	I _F = 5A, V _{GS} = 0V			1	V
Reverse Recovery Time	t _{rr}	I _F = 5A, dI _F /dt = 100A / μS		277		nS
Reverse Recovery Charge	Q _{rr}				1.8	

¹Pulse test : Pulse Width ≤ 300 μsec, Duty Cycle ≤ 2%.

²Independent of operating temperature.

³Pulse width limited by maximum junction temperature.

P0550EI

N-Channel Enhancement Mode MOSFET

Output Characteristics

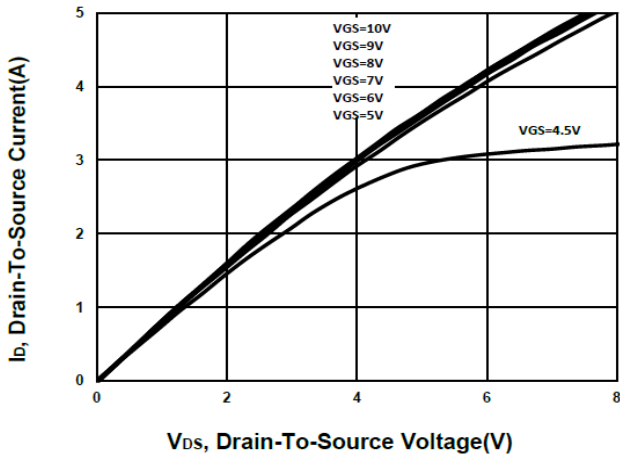

Transfer Characteristics

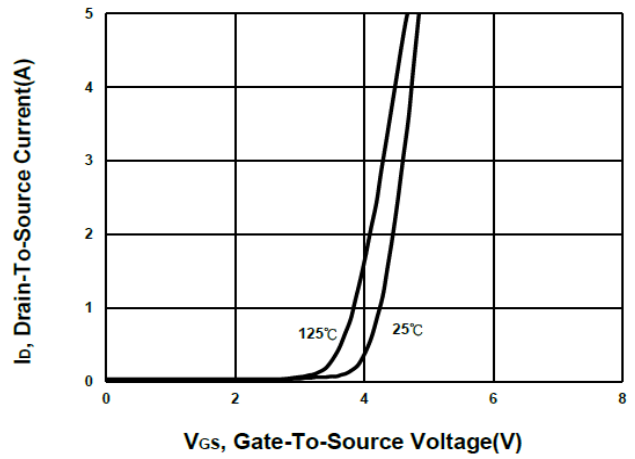

Gate charge Characteristics

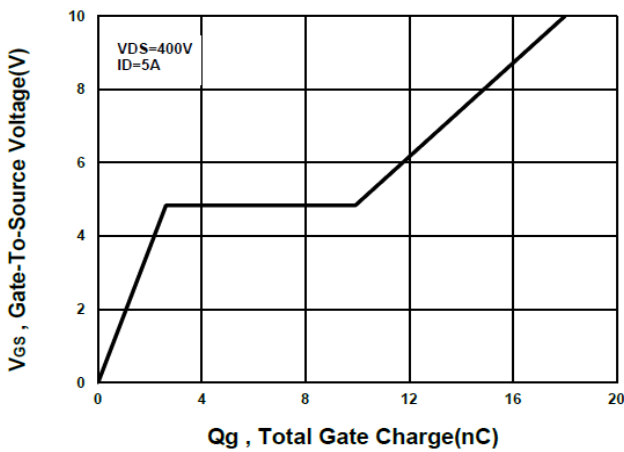

Capacitance Characteristic

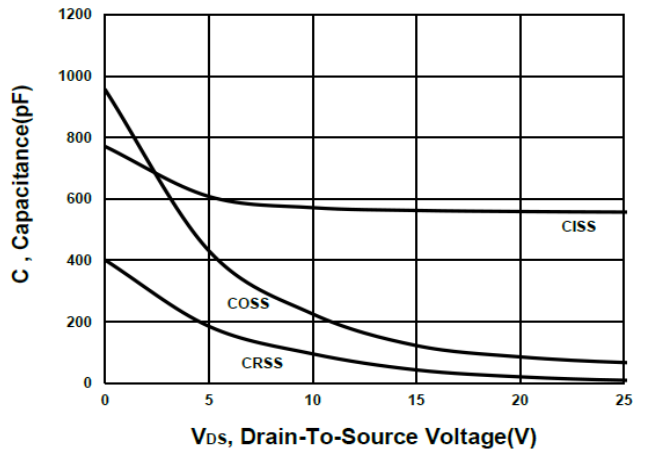

On-Resistance VS Gate-To-Source

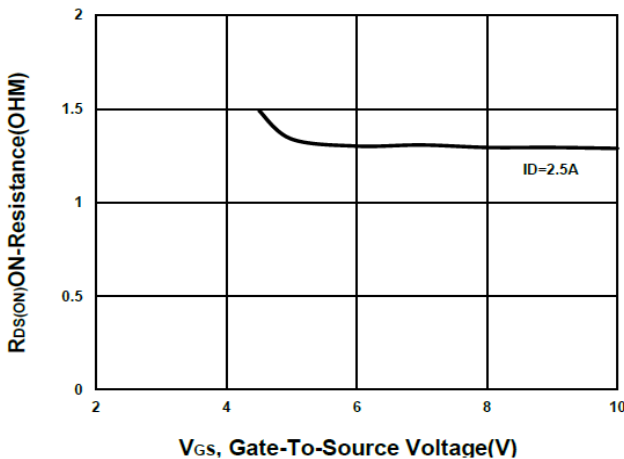

On-Resistance VS Drain Current

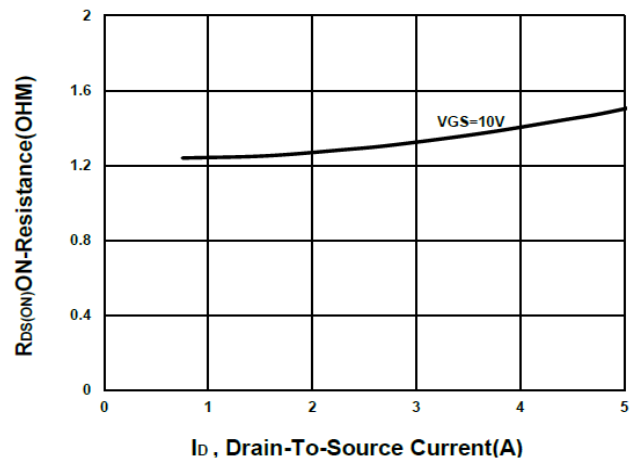

P0550EI

N-Channel Enhancement Mode MOSFET

On-Resistance VS Temperature

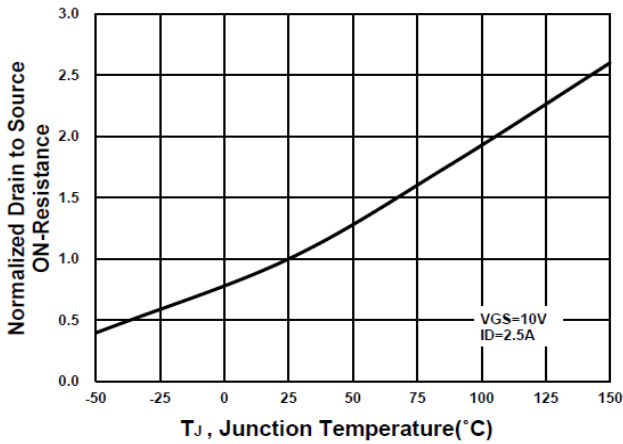

Source-Drain Diode Forward Voltage

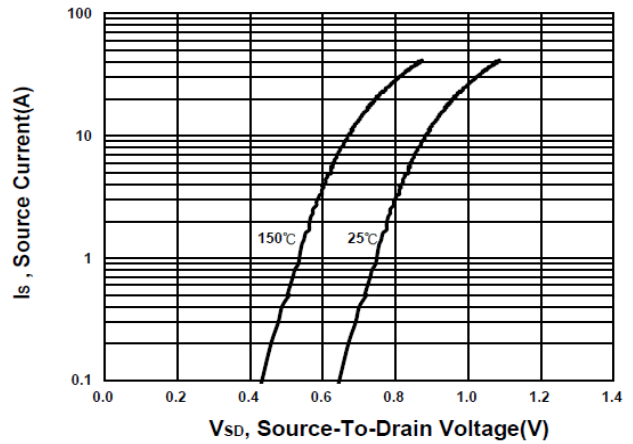

Safe Operating Area

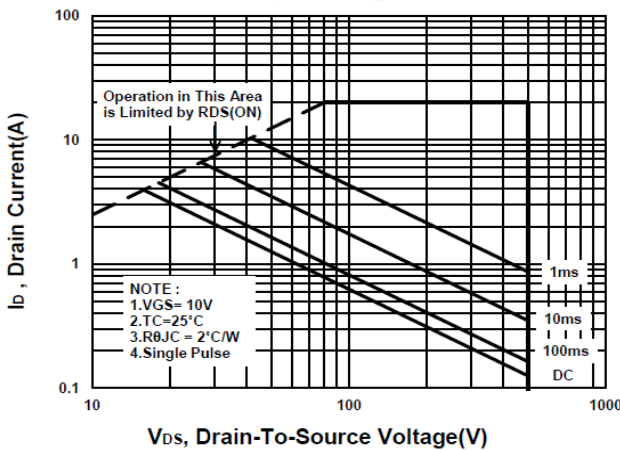

Single Pulse Maximum Power Dissipation

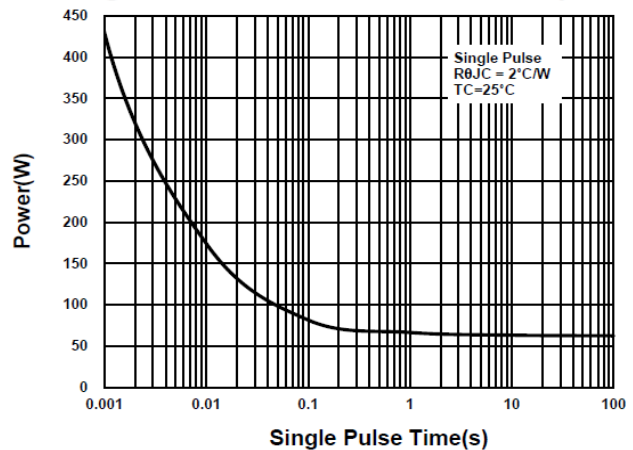

Transient Thermal Response Curve

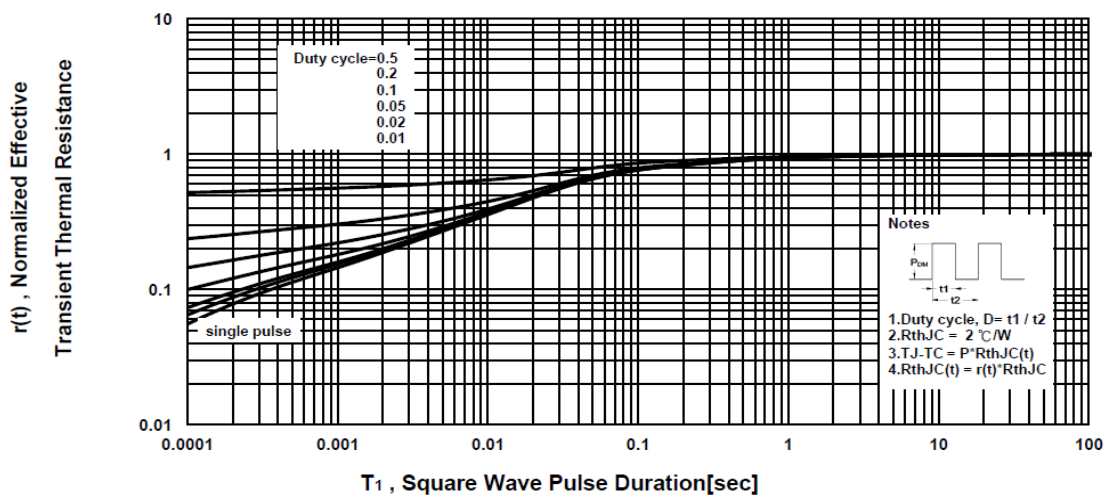

P0550EI
N-Channel Enhancement Mode MOSFET

Package Dimension

TO-251 MECHANICAL DATA

Dimension	mm			Dimension	mm		
	Min.	Typ.	Max.		Min.	Typ.	Max.
A	14	15	17.14	H	0.89		1.7
B	2.1	2.3	2.5	I	6.3		6.8
C	0.4	0.5	0.6	J	4.8		5.5
D	0.35	0.5	0.65	K	0.5	0.84	1.14
E	0.9	1.1	1.5	L	0.4	0.76	0.912
F	7		9.65	M		2.3	
G	5.3		6.22	N	1.4	2.16	2.23

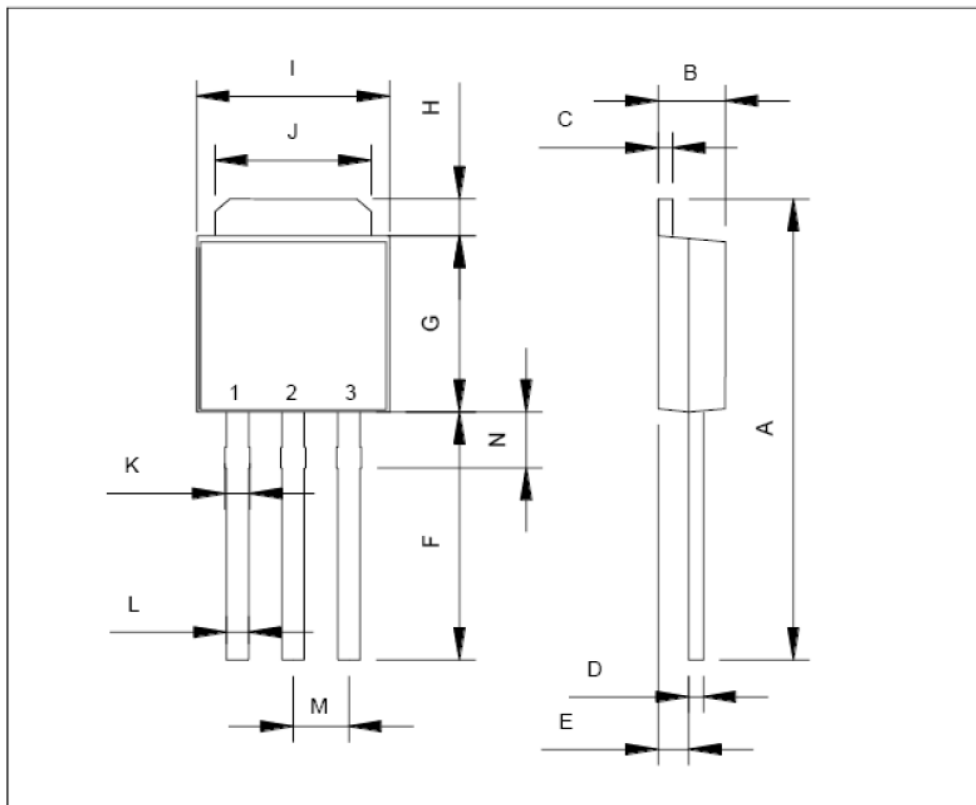

P0550EI

N-Channel Enhancement Mode MOSFET

A. Marking Information

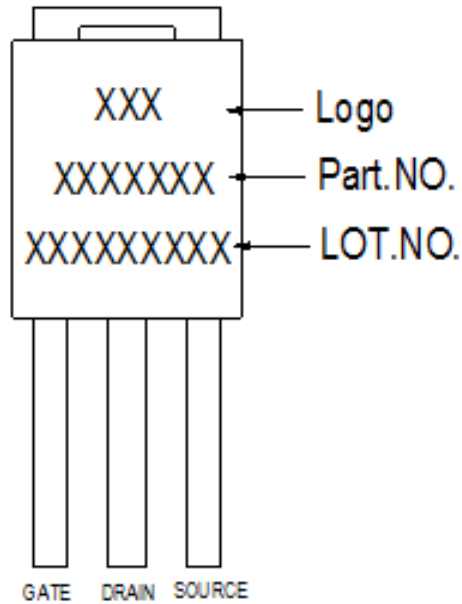

B. Tape & Reel Information: 75pcs/Tube

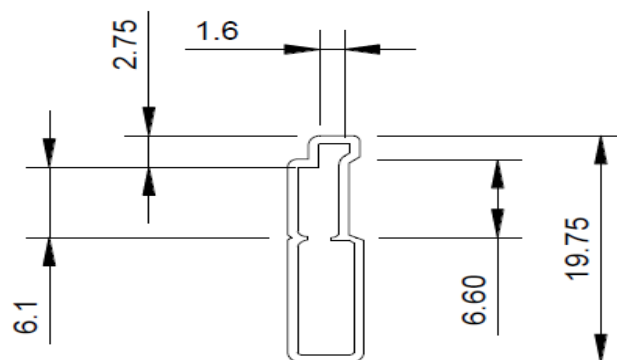
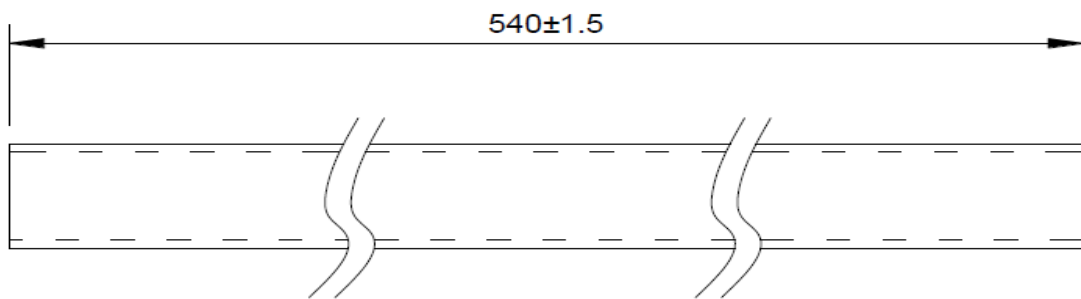

P0550EI
N-Channel Enhancement Mode MOSFET

C. Lot.No. & Date Code rule

1.LOT.NO.

M N 15M21 03

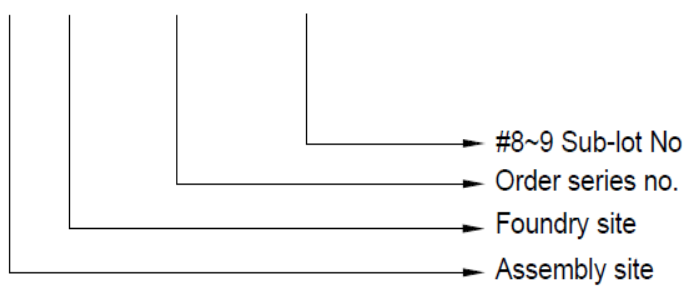

2.Date Code

D Y M X XXX

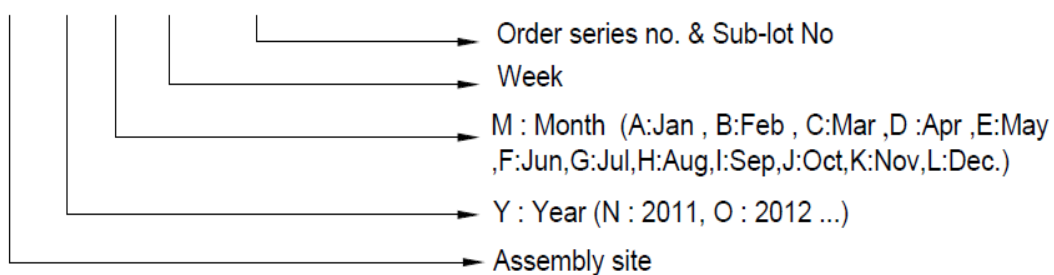

3.Date Code (for Small package)

XX Y WW

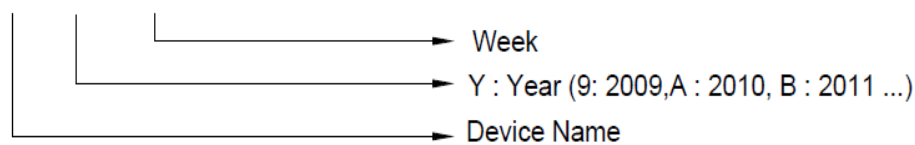



P0550EI

N-Channel Enhancement Mode MOSFET

D.Label rule

标签内容(Label content)



1	Label Size	30 * 90 mm
2	Font style	Times New Roman or Arial (或可区分英文"0"和数字"0", "G"和"Q"的字型即可)
3	Great Power	Height: 4 mm
4	Package	Height: 2 mm
5	Date	Height: 2 mm Shipping date: YYYY/MM/DD, ex. 2008/09/12
6	Device	Height: 3 mm (Max: 16 Digit)
7	Lot	Height: 3 mm (Max: 9 Digit) Sub lot
8	D/C	Height: 3 mm (Max: 7 Digit)
9	QTY	Height: 3 mm (Max: 6 Digit) Thousand mark is no needed
10	Pb Free label	 Diameter: 1 cm bottom color: Green Font color: Black Font style: Arial
11	Halogen Free label	 Diameter: 1 cm bottom color: Green Font color: Black Font style: Arial
12	Scan info	Device / Lot / D/C / QTY , Insert " / " between every parts. for example: P3055LDG/G12345601/GGG2301/2000 DPI (Dots per inch): Over 300 dpi Code : Code 128 Height: 6 mm at least