

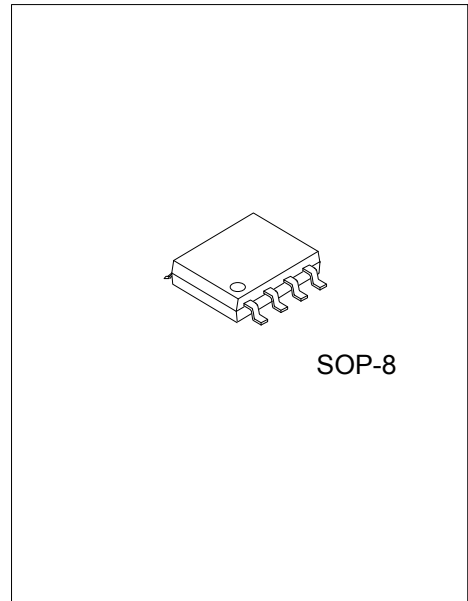

P1482

LINEAR INTEGRATED CIRCUIT

**2A, 18V, 340KHZ
SYNCHRONOUS RECTIFIED
STEP-DOWN CONVERTER**



■ DESCRIPTION

The UTC **P1482** is a synchronous buck regulator. The device provides 2A of continuous load current over a wide input voltage of 6V~18V. Current mode control provides fast transient response and cycle-by-cycle current limit. An adjustable soft-start prevents inrush current at turn-on.

The UTC **P1482** can provide low-ripple power, high efficiency, and perfect transient characteristics. The duty ratio varies linearly from 0% to 92% in the PWM control. The error amplifier circuit and soft-start circuit included in this device can prevent overshoot at startup. An enable function, an over current protect (OCP) function and short circuit protect (SCP) are also build inside, and when OCP happens, the operation frequency will be reduced.

■ FEATURES

- * 2A Output Current
- * Wide 6V~18V Operating Input Range
- * Integrated Power MOSFET Switches
- * Programmable Soft-Start
- * Stable with Low ESR Ceramic Output Capacitors
- * Fixed 340KHz Frequency
- * Cycle-by-Cycle Over Current Protection

■ ORDERING INFORMATION

Ordering Number		Package	Packing
Lead Free	Halogen Free		
P1482L-S08-R	P1482G-S08-R	SOP-8	Tape Reel

<p>P1482G-S08-R</p> <ul style="list-style-type: none"> (1)Packing Type (2)Package Type (3)Green Package 	<ul style="list-style-type: none"> (1) R: Tape Reel (2) S08: SOP-8 (3) G: Halogen Free and Lead Free, L: Lead Free
--	---

■ MARKING

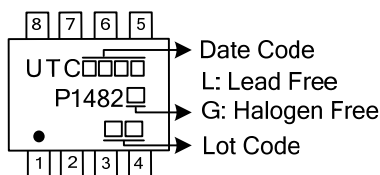

■ PIN CONFIGURATION

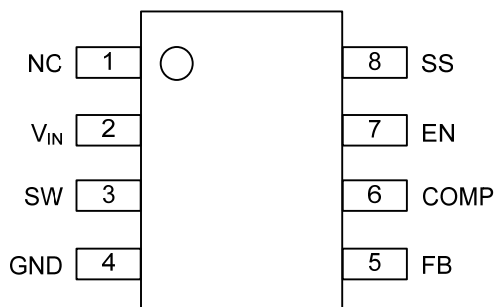

■ PIN DESCRIPTION

PIN NO.	PIN NAME	DESCRIPTION
1	NC	No Bonding
2	V _{IN}	IC power supply pin.
3	SW	Power Switching Output.
4	GND	Ground.
5	FB	Feedback Input.
6	COMP	Compensation Node.
7	EN	Enable Input.
8	SS	Soft-Start Control Input.

■ BLOCK DIAGRAM

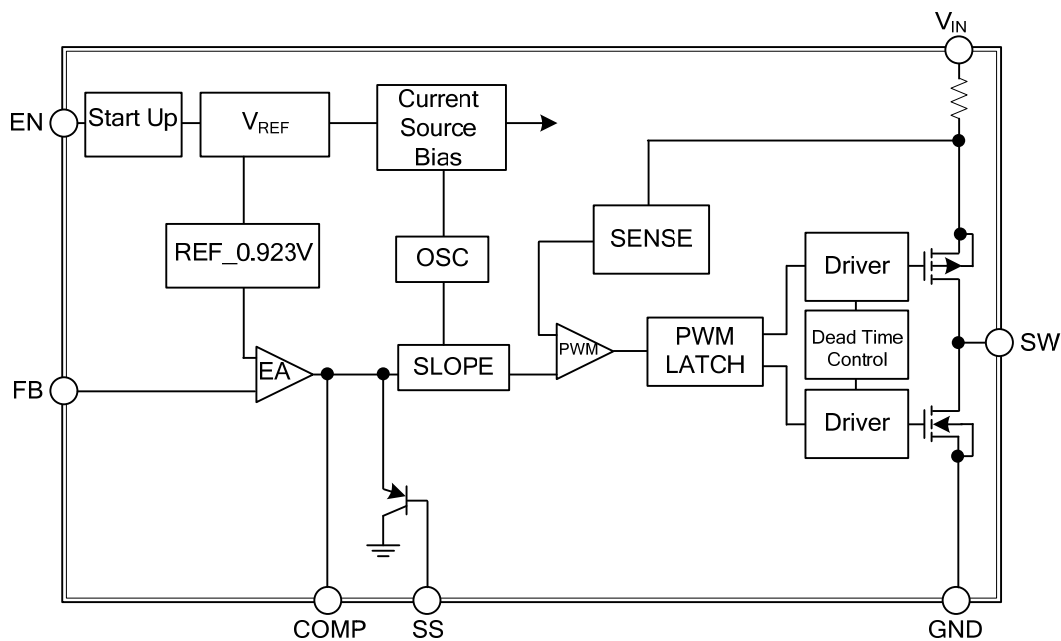

■ ABSOLUTE MAXIMUM RATING ($T_A=25^{\circ}\text{C}$, unless otherwise specified)

PARAMETER	SYMBOL	RATINGS	UNIT
Supply Voltage	V_{IN}	-0.3 ~ +18	V
Switch Node Voltage	V_{SW}	18	V
All Other Pins		-0.3 ~ +6	V
Continuous Power Dissipation	P_D	Internally Limited	W
Junction Temperature	T_J	150	$^{\circ}\text{C}$
Storage Temperature	T_{STG}	-65 ~ +150	$^{\circ}\text{C}$

Note: Absolute maximum ratings are those values beyond which the device could be permanently damaged.
Absolute maximum ratings are stress ratings only and functional device operation is not implied.

■ THERMAL DATA

PARAMETER	SYMBOL	RATING	UNIT
Junction to Ambient	θ_{JA}	143	$^{\circ}\text{C}/\text{W}$

Note: Surface mounted on 1 in² copper pad of FR4 board.

■ RECOMMENDED OPERATING CONDITIONS

PARAMETER	SYMBOL	RATING	UNIT
Input Voltage	V_{IN}	6 ~ 18	V
Output Voltage	V_{OUT}	0.923 ~ 15	V
Ambient Operating Temperature	T_{OPR}	-40 ~ +85	$^{\circ}\text{C}$

Note: The device is not guaranteed to function outside of its operating conditions.

■ ELECTRICAL CHARACTERISTICS ($V_{IN}=12\text{V}$, $T_A=25^{\circ}\text{C}$, unless otherwise specified)

PARAMETER	SYMBOL	TEST CONDITIONS	MIN	TYP	MAX	UNIT
Supply Current		$V_{EN}=2.0\text{V}$, $V_{FB}=1.0\text{V}$		3.5	5	mA
Feedback Voltage	V_{FB}	$6\text{V} \leq V_{IN} \leq 18\text{V}$	0.900	0.923	0.946	V
High-Side Switch On Resistance (Note 1)	$R_{DS(ON)1}$			110		m Ω
Low-Side Switch On Resistance (Note 1)	$R_{DS(ON)2}$			100		m Ω
High-Side Switch Leakage Current		$V_{EN}=0\text{V}$, $V_{SW}=0\text{V}$			10	μA
Upper Switch Current Limit		Minimum Duty Cycle	2.4	3.4		A
Lower Switch Current Limit		From Drain to Source		1.1		A
COMP to Current Sense Transconductance	G_{CS}			5		A/V
Oscillation Frequency	F_{OSC1}		300	365	430	KHz
Short Circuit Oscillation Frequency	F_{OSC2}	$V_{FB}=0\text{V}$		40		KHz
Maximum Duty Cycle	D_{MAX}	$V_{FB}=1.0\text{V}$		92		%
EN Shutdown Threshold Voltage		V_{EN} Rising	0.7	0.9	2.0	V
Input Under Voltage Lockout Threshold		V_{IN} Rising		4		V
Soft-Start Current		$V_{SS}=0\text{V}$		15		μA
Thermal Shutdown (Note)				160		$^{\circ}\text{C}$

Note: Guaranteed by design, not tested.

■ TYPICAL APPLICATION CIRCUIT

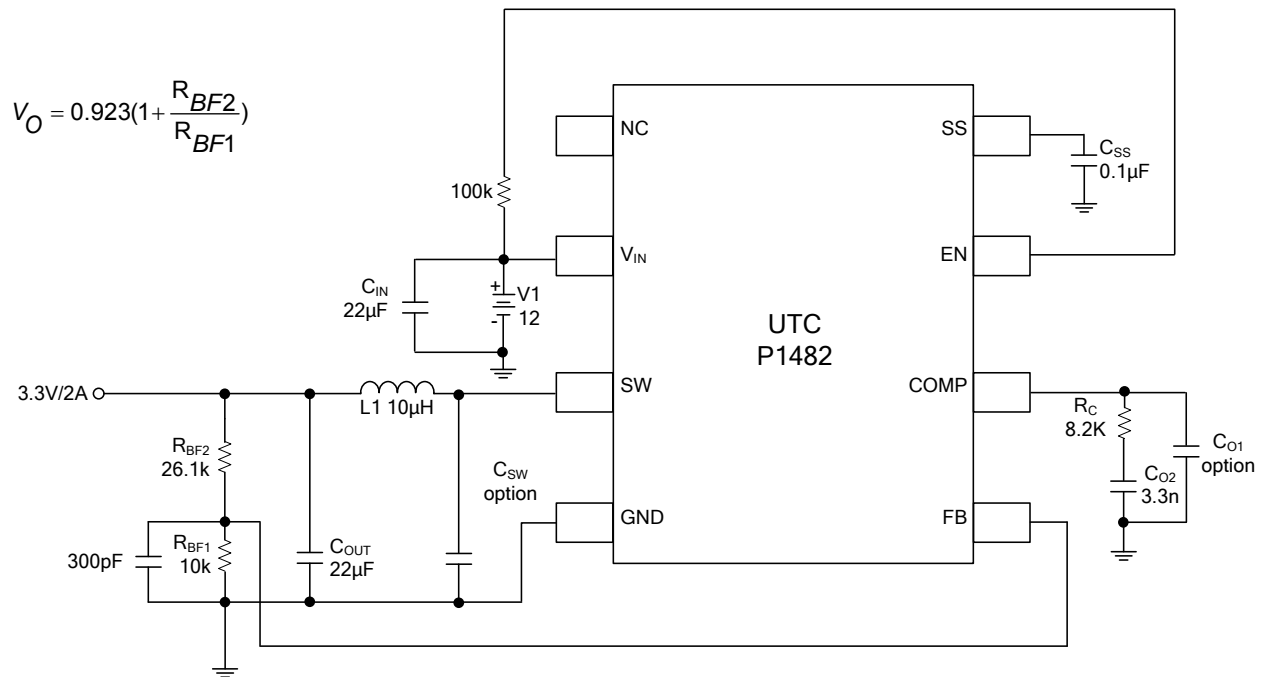

■ TYPICAL CHARACTERISTICS

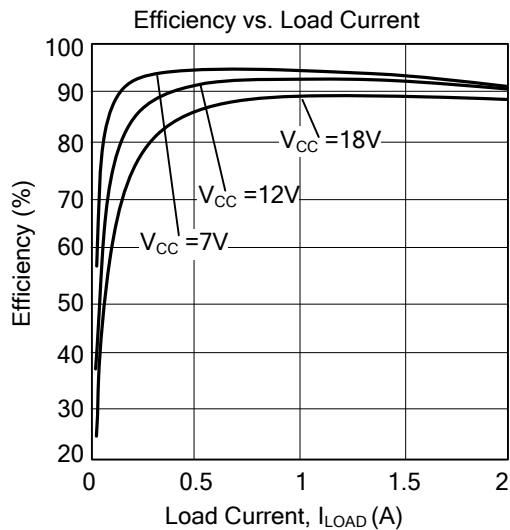
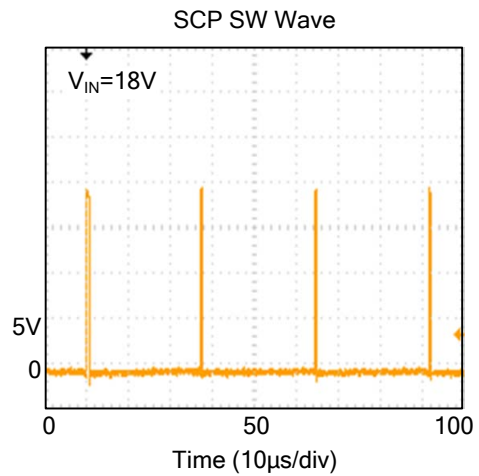
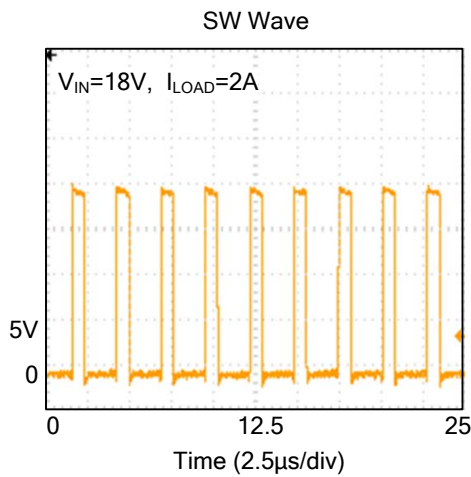

UTC assumes no responsibility for equipment failures that result from using products at values that exceed, even momentarily, rated values (such as maximum ratings, operating condition ranges, or other parameters) listed in products specifications of any and all UTC products described or contained herein. UTC products are not designed for use in life support appliances, devices or systems where malfunction of these products can be reasonably expected to result in personal injury. Reproduction in whole or in part is prohibited without the prior written consent of the copyright owner. The information presented in this document does not form part of any quotation or contract, is believed to be accurate and reliable and may be changed without notice.