

P1504HV

Dual N-Channel Enhancement Mode MOSFET

PRODUCT SUMMARY

$V_{(BR)DSS}$	$R_{DS(ON)}$	I_D
40V	23m Ω @ $V_{GS} = 10V$	7A

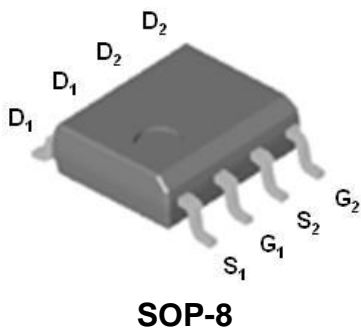

100% UIS tested
100% Rg tested

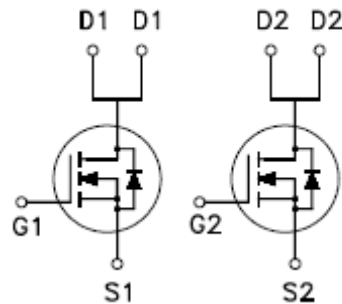

ABSOLUTE MAXIMUM RATINGS ($T_A = 25\text{ }^\circ\text{C}$ Unless Otherwise Noted)

PARAMETERS/TEST CONDITIONS	SYMBOL	LIMITS	UNITS
Drain-Source Voltage	V_{DS}	40	V
Gate-Source Voltage	V_{GS}	± 25	
Continuous Drain Current	I_D	$T_A = 25\text{ }^\circ\text{C}$	7
		$T_A = 100\text{ }^\circ\text{C}$	4
Pulsed Drain Current ¹	I_{DM}	30	A
Avalanche Current	I_{AS}	28	
Avalanche Energy	E_{AS}	41	mJ
Power Dissipation	P_D	$T_A = 25\text{ }^\circ\text{C}$	2
		$T_A = 100\text{ }^\circ\text{C}$	0.8
Operating Junction & Storage Temperature Range	T_j, T_{stg}	-55 to 150	$^\circ\text{C}$

THERMAL RESISTANCE RATINGS

THERMAL RESISTANCE	SYMBOL	TYPICAL	MAXIMUM	UNITS
Junction-to-Lead	$R_{\theta JL}$		25	$^\circ\text{C} / \text{W}$
Junction-to-Ambient	$R_{\theta JA}$		62.5	

¹Pulse width limited by maximum junction temperature.

P1504HV

Dual N-Channel Enhancement Mode MOSFET

ELECTRICAL CHARACTERISTICS (T_J = 25 °C, Unless Otherwise Noted)

PARAMETER	SYMBOL	TEST CONDITIONS	LIMITS			UNITS
			MIN	TYP	MAX	
STATIC						
Drain-Source Breakdown Voltage	V _{(BR)DSS}	V _{GS} = 0V, I _D = 250μA	40			V
Gate Threshold Voltage	V _{GS(th)}	V _{DS} = V _{GS} , I _D = 250μA	1.5	2.3	3.0	V
Gate-Body Leakage	I _{GSS}	V _{DS} = 0V, V _{GS} = ±25V			±100	nA
Zero Gate Voltage Drain Current	I _{DSS}	V _{DS} = 32V, V _{GS} = 0V			1	μA
		V _{DS} = 30V, V _{GS} = 0V, T _J = 70 °C			10	
On-State Drain Current ¹	I _{D(ON)}	V _{DS} = 5V, V _{GS} = 10V	30			A
Drain-Source On-State Resistance ¹	R _{DS(ON)}	V _{GS} = 7V, I _D = 6.5A		22	28	mΩ
		V _{GS} = 10V, I _D = 6.5A		20	23	
Forward Transconductance ¹	g _{fs}	V _{DS} = 5V, I _D = 6.5A		30		S
DYNAMIC						
Input Capacitance	C _{iss}	V _{GS} = 0V, V _{DS} = 20V, f = 1MHz		1132		pF
Output Capacitance	C _{oss}			222		
Reverse Transfer Capacitance	C _{rss}			146		
Gate Resistance	R _g	V _{GS} = 0V, V _{DS} = 0V, f = 1MHz		1.6		Ω
Total Gate Charge ²	Q _g	V _{DS} = 0.5V _{(BR)DSS} , V _{GS} = 10V, I _D = 6.5A		23		nC
Gate-Source Charge ²	Q _{gs}			8		
Gate-Drain Charge ²	Q _{gd}			4		
Turn-On Delay Time ²	t _{d(on)}	V _{DS} = 0.5V _{(BR)DSS} , I _D ≅ 6.5A, V _{GS} = 10V, R _G = 6Ω		10		nS
Rise Time ²	t _r			20		
Turn-Off Delay Time ²	t _{d(off)}			35		
Fall Time ²	t _f			52		
SOURCE-DRAIN DIODE RATINGS AND CHARACTERISTICS						
Continuous Current	I _S				7	A
Forward Voltage ¹	V _{SD}	I _F = 6.5A, V _{GS} = 0V			1.3	V
Reverse Recovery Time	t _{rr}	I _F = 6.5A, di _F /dt = 100A /μS		25		nS
Reverse Recovery Charge	Q _{rr}				18	

¹Pulse test : Pulse Width ≤ 300 μsec, Duty Cycle ≤ 2%.

²Independent of operating temperature.

P1504HV

Dual N-Channel Enhancement Mode MOSFET

Output Characteristics

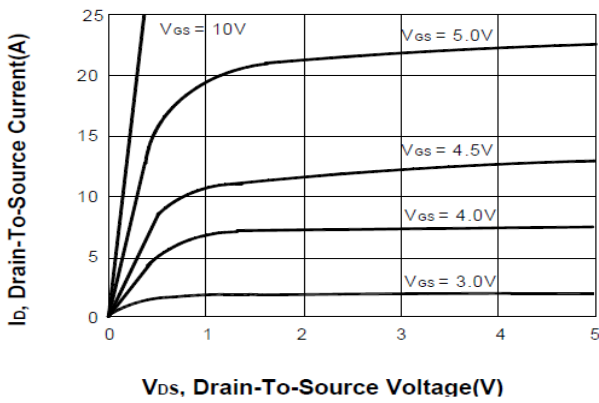

Transfer Characteristics

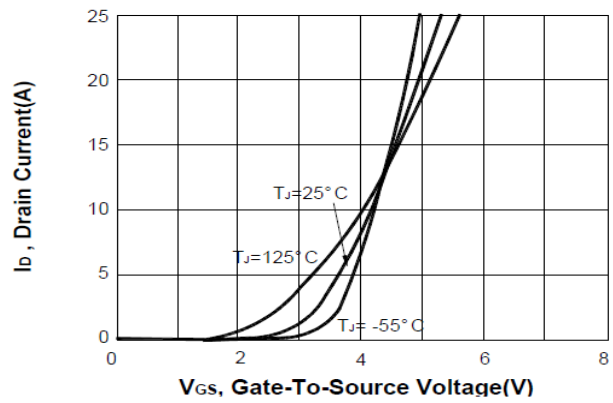

On-Resistance VS Gate-To-Source

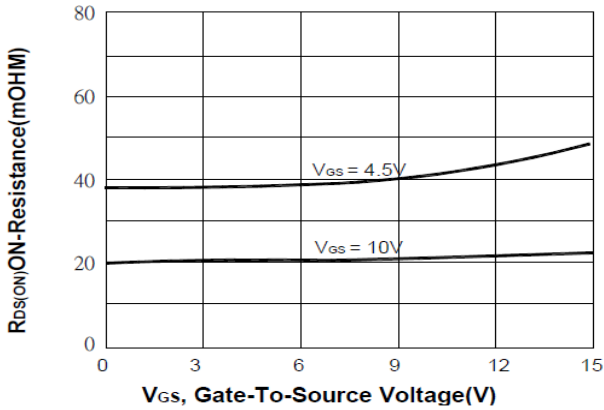

Capacitance Characteristic

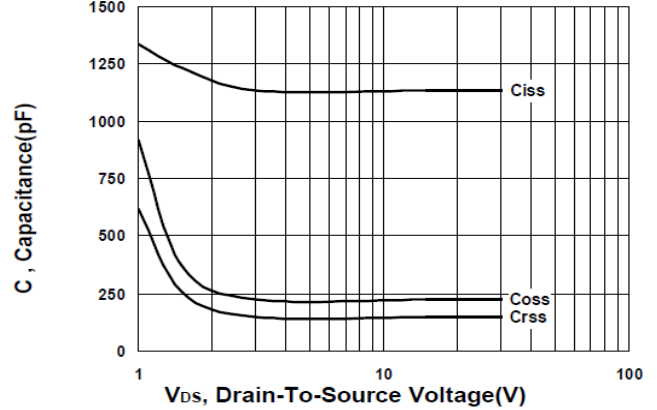

Gate charge Characteristics

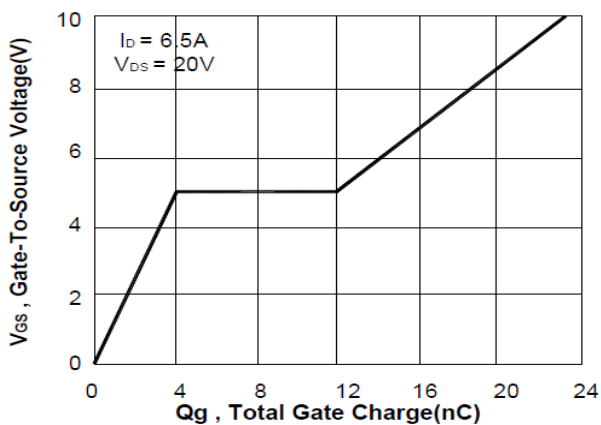

On-Resistance vs. Junction Temperature

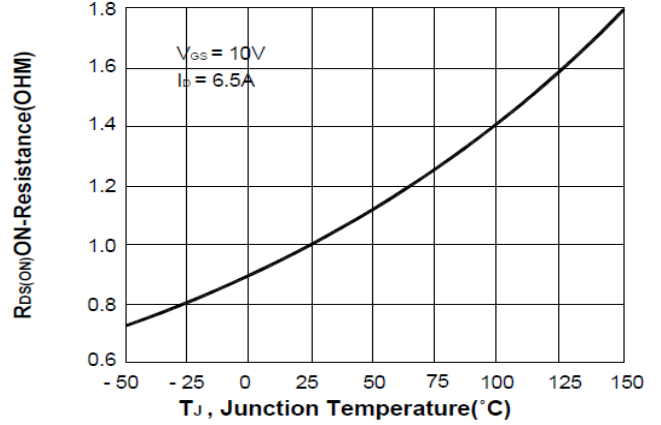

P1504HV

Dual N-Channel Enhancement Mode MOSFET

Body Diode Forward Voltage VS Source current

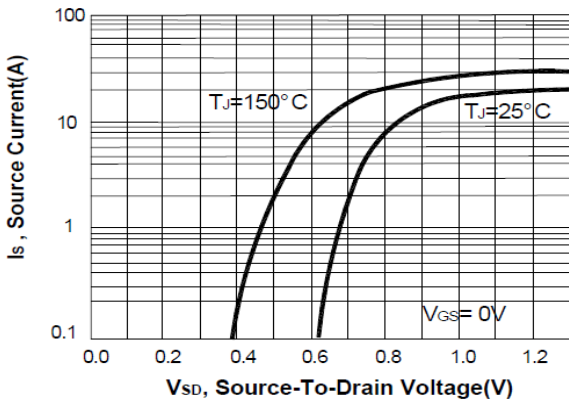

On-Resistance VS Gate-To-Source

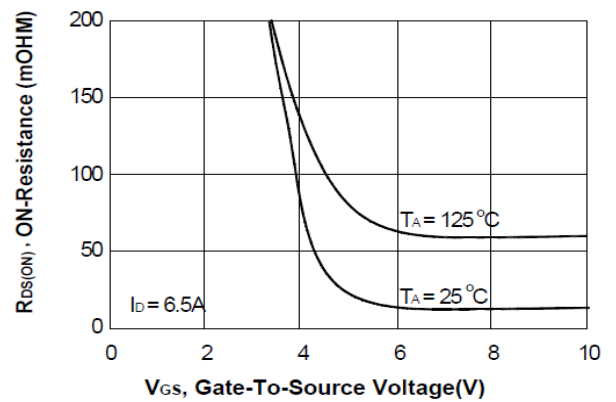

Safe Operating Area

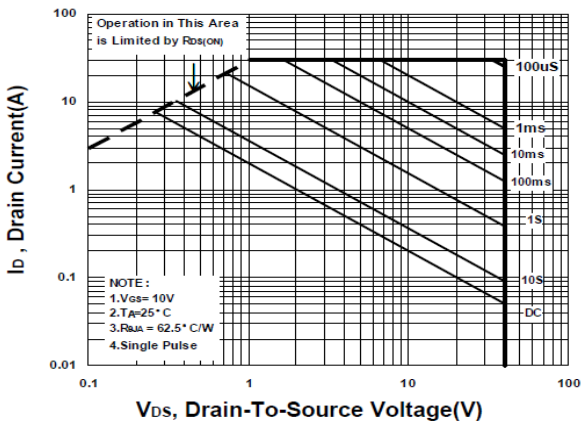

Single Pulse Maximum Power Dissipation

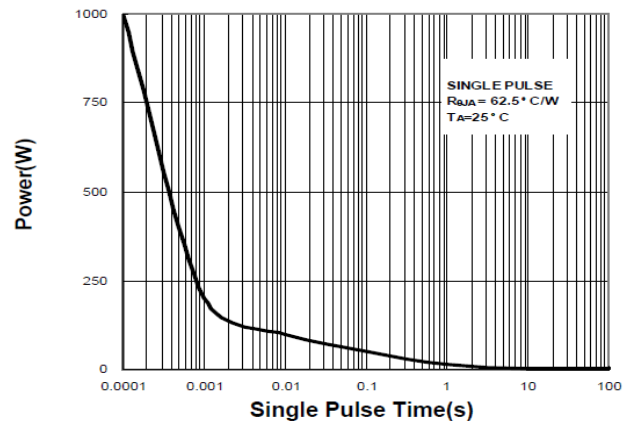

Transient Thermal Response Curve

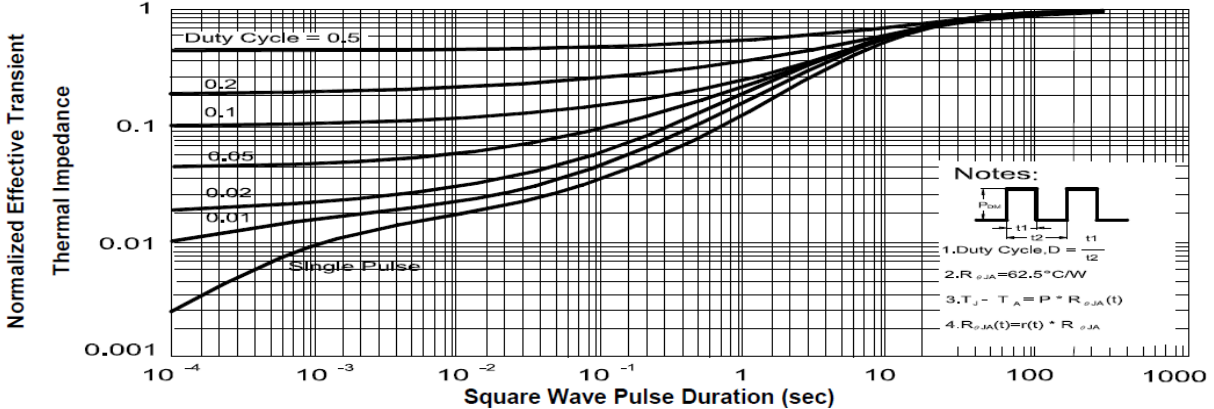

P1504HV

Dual N-Channel Enhancement Mode MOSFET

Package Dimension

SOP-8 MECHANICAL DATA

Dimension	mm			Dimension	mm		
	Min.	Typ.	Max.		Min.	Typ.	Max.
A	4.8	4.9	5.0	H	0.4	0.6	0.93
B	3.8	3.9	4.0	I	0.19	0.21	0.25
C	5.79	6.0	6.2	J	0.25	0.375	0.5
D	0.33	0.4	0.51	K	0°	3°	18°
E	1.25	1.27	1.29				
F	1.1	1.3	1.65				
G	0.05	0.15	0.25				

