

# P1650GTF

## N-Channel Enhancement Mode MOSFET

### PRODUCT SUMMARY

$V_{(BR)DSS}$	$R_{DS(ON)}$	$I_D$
500V	360mΩ @ $V_{GS} = 10V$	16A

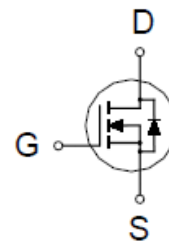
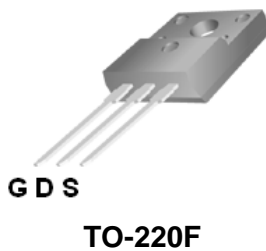

### ABSOLUTE MAXIMUM RATINGS ( $T_A = 25\text{ }^\circ\text{C}$ Unless Otherwise Noted)

PARAMETERS/TEST CONDITIONS		SYMBOL	LIMITS	UNITS
Drain-Source Voltage		$V_{DS}$	500	V
Gate-Source Voltage		$V_{GS}$	±30	
Continuous Drain Current <sup>2</sup>	$T_C = 25\text{ }^\circ\text{C}$	$I_D$	16	A
	$T_C = 100\text{ }^\circ\text{C}$		10	
Pulsed Drain Current <sup>1,2</sup>		$I_{DM}$	60	
Avalanche Current <sup>3</sup>		$I_{AS}$	9	
Avalanche Energy <sup>3</sup>		$E_{AS}$	410	mJ
Power Dissipation	$T_C = 25\text{ }^\circ\text{C}$	$P_D$	56.8	W
	$T_C = 100\text{ }^\circ\text{C}$		22.7	
Operating Junction & Storage Temperature Range		$T_J, T_{stg}$	-55 to 150	$^\circ\text{C}$

### THERMAL RESISTANCE RATINGS

THERMAL RESISTANCE	SYMBOL	TYPICAL	MAXIMUM	UNITS
Junction-to-Case	$R_{\theta JC}$		2.2	$^\circ\text{C} / \text{W}$
Junction-to-Ambient	$R_{\theta JA}$		62.5	

<sup>1</sup>Pulse width limited by maximum junction temperature.

<sup>2</sup>Limited only by maximum temperature allowed

<sup>3</sup> $V_{DD} = 50V$ ,  $L = 10\text{mH}$ , starting  $T_J = 25\text{ }^\circ\text{C}$

# P1650GTF

## N-Channel Enhancement Mode MOSFET

### ELECTRICAL CHARACTERISTICS (T<sub>J</sub> = 25 °C, Unless Otherwise Noted)

PARAMETER	SYMBOL	TEST CONDITIONS	LIMITS			UNITS
			MIN	TYP	MAX	
<b>STATIC</b>						
Drain-Source Breakdown Voltage	V <sub>(BR)DSS</sub>	V <sub>GS</sub> = 0V, I <sub>D</sub> = 250μA	500			V
Gate Threshold Voltage	V <sub>GS(th)</sub>	V <sub>DS</sub> = V <sub>GS</sub> , I <sub>D</sub> = 250μA	2	2.7	4	
Gate-Body Leakage	I <sub>GSS</sub>	V <sub>DS</sub> = 0V, V <sub>GS</sub> = ±30V			±100	nA
Zero Gate Voltage Drain Current	I <sub>DSS</sub>	V <sub>DS</sub> = 500V, V <sub>GS</sub> = 0V, T <sub>C</sub> = 25 °C			1	μA
		V <sub>DS</sub> = 400V, V <sub>GS</sub> = 0V, T <sub>C</sub> = 100 °			100	
Drain-Source On-State Resistance <sup>1</sup>	R <sub>DS(ON)</sub>	V <sub>GS</sub> = 10V, I <sub>D</sub> = 8A		296	360	mΩ
Forward Transconductance <sup>1</sup>	g <sub>fs</sub>	V <sub>DS</sub> = 10V, I <sub>D</sub> = 8A		16		S
<b>DYNAMIC</b>						
Input Capacitance	C <sub>iss</sub>	V <sub>GS</sub> = 0V, V <sub>DS</sub> = 25V, f = 1MHz		2707		pF
Output Capacitance	C <sub>oss</sub>			236		
Reverse Transfer Capacitance	C <sub>riss</sub>			17		
Total Gate Charge <sup>2</sup>	Q <sub>g</sub>	V <sub>DD</sub> = 400V, V <sub>GS</sub> = 10V, I <sub>D</sub> = 16A		59		nC
Gate-Source Charge <sup>2</sup>	Q <sub>gs</sub>			17		
Gate-Drain Charge <sup>2</sup>	Q <sub>gd</sub>			18		
Turn-On Delay Time <sup>2</sup>	t <sub>d(on)</sub>	V <sub>DD</sub> = 250V, I <sub>D</sub> ≅ 16A, R <sub>G</sub> = 25Ω		45		nS
Rise Time <sup>2</sup>	t <sub>r</sub>			180		
Turn-Off Delay Time <sup>2</sup>	t <sub>d(off)</sub>			130		
Fall Time <sup>2</sup>	t <sub>f</sub>			100		
<b>SOURCE-DRAIN DIODE RATINGS AND CHARACTERISTICS (T<sub>J</sub> = 25 °C)</b>						
Continuous Current <sup>3</sup>	I <sub>S</sub>				16	A
Forward Voltage <sup>1</sup>	V <sub>SD</sub>	I <sub>F</sub> = 16A, V <sub>GS</sub> = 0V			1	V
Reverse Recovery Time	t <sub>rr</sub>	I <sub>F</sub> = 16A, di <sub>F</sub> /dt = 100A/μs		376		nS
Reverse Recovery Charge	Q <sub>rr</sub>				5.2	

<sup>1</sup>Pulse test : Pulse Width ≤ 300 μsec, Duty Cycle ≤ 2%.

<sup>2</sup>Independent of operating temperature.

<sup>3</sup>Pulse width limited by maximum junction temperature.

# P1650GTF

## N-Channel Enhancement Mode MOSFET

**Output Characteristics**

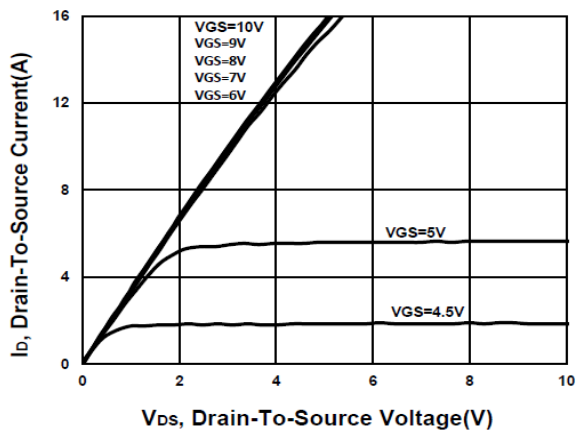

**Transfer Characteristics**

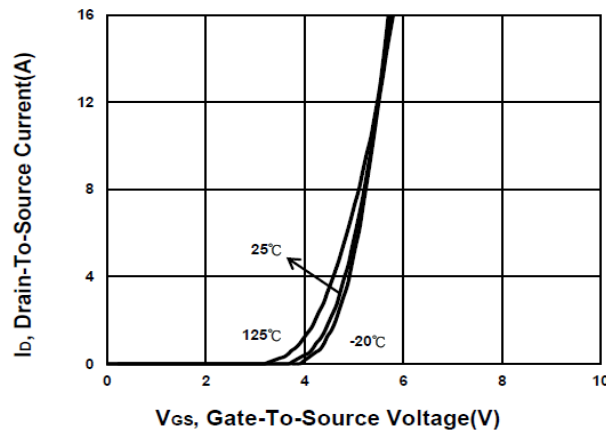

**On-Resistance VS Temperature**

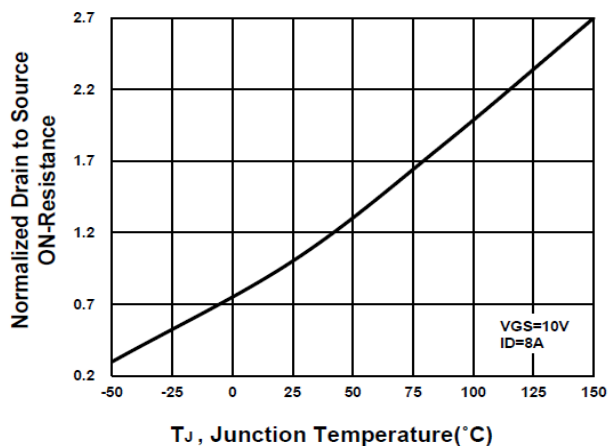

**Capacitance Characteristic**

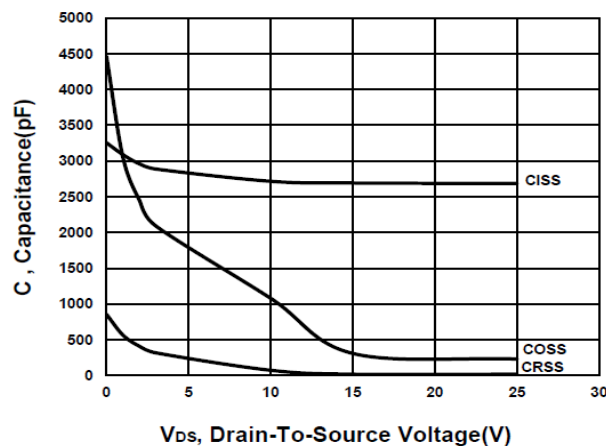

**Gate charge Characteristics**

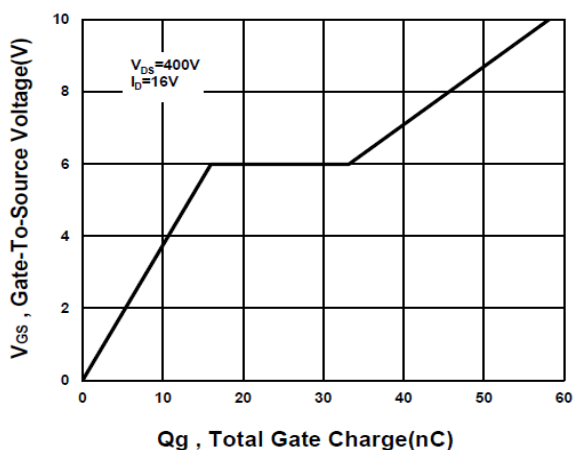

**Source-Drain Diode Forward Voltage**

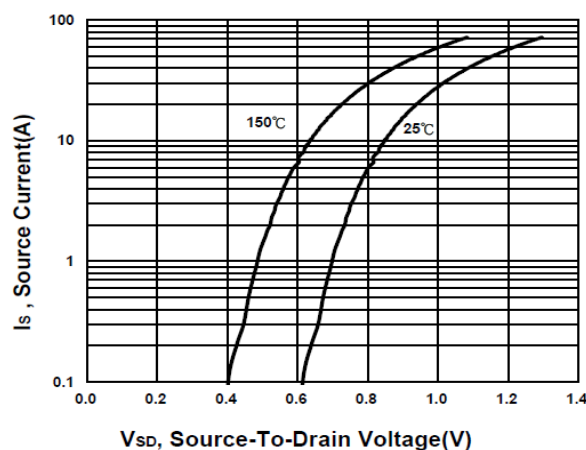

# P1650GTF

## N-Channel Enhancement Mode MOSFET

**Safe Operating Area**

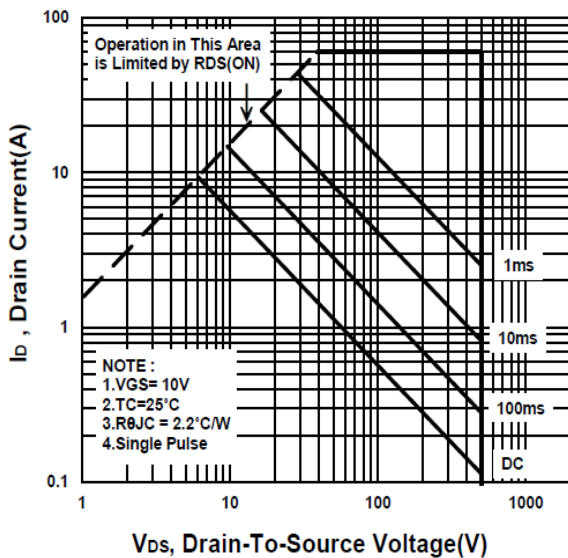

**Single Pulse Maximum Power Dissipation**

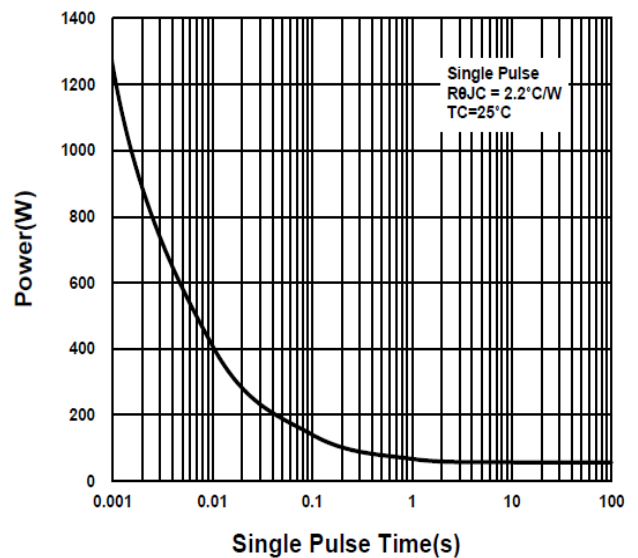

**Transient Thermal Response Curve**

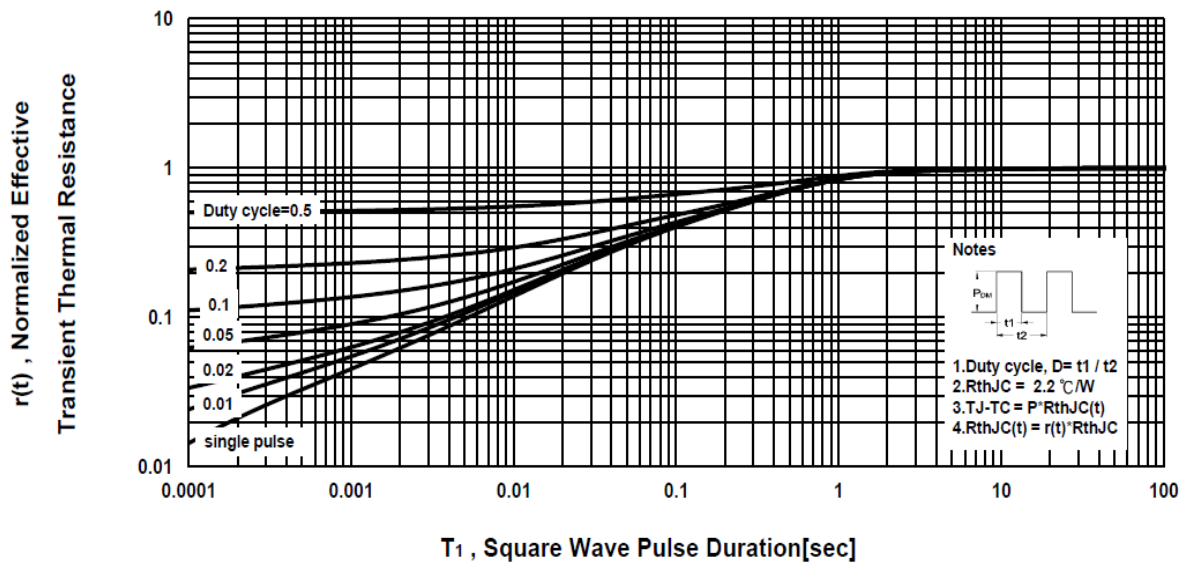

# P1650GTF

## N-Channel Enhancement Mode MOSFET

### Package Dimension

### TO-220F (3-Lead) MECHANICAL DATA

Dimension	mm			Dimension	mm		
	Min.	Typ.	Max.		Min.	Typ.	Max.
A	4.4		4.93	e	2.34		2.74
A1	2.34		3.1	F	27.2		30.6
B	18.8		20	G	7.7		9.39
b	0.65		1	H	6.18		6.82
b1	0.93		1.6	L	12.7		14.2
b2	0.95		1.6	L1	2.88		3.7
c	0.4		1	P	2.98		3.7
D	13.5		16.4	Q	2.3		2.96
D1	6.48		6.95	q	3.1		3.8
E	9.8		10.4				

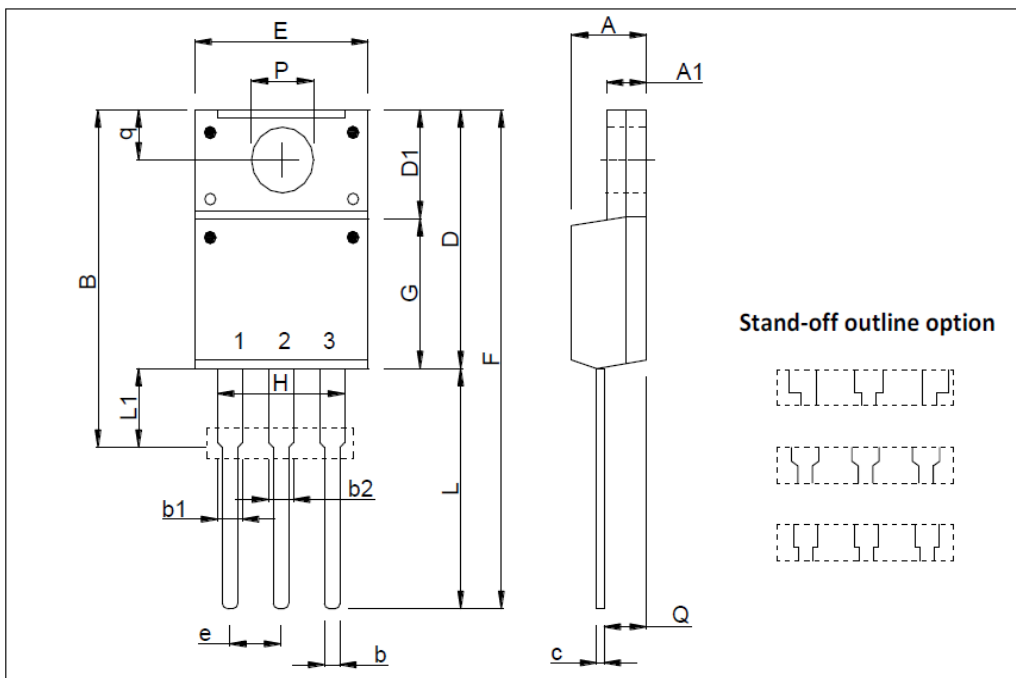

\*因各家封装模具不同而外观略有所差异，不影响电性及Layout。

# P1650GTF

## N-Channel Enhancement Mode MOSFET

### A. Marking Information

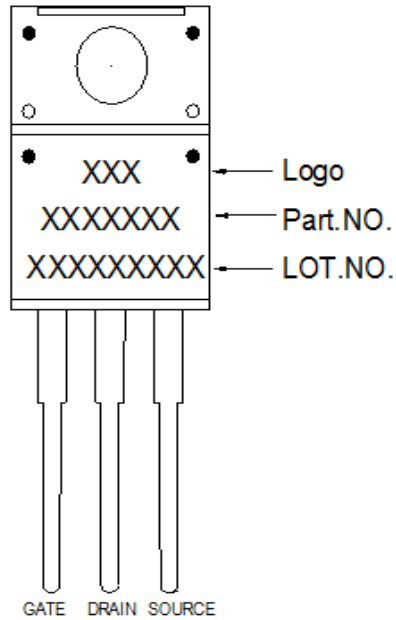

### B. Tape & Reel Information: 50pcs/Tube (2000pcs/Box)

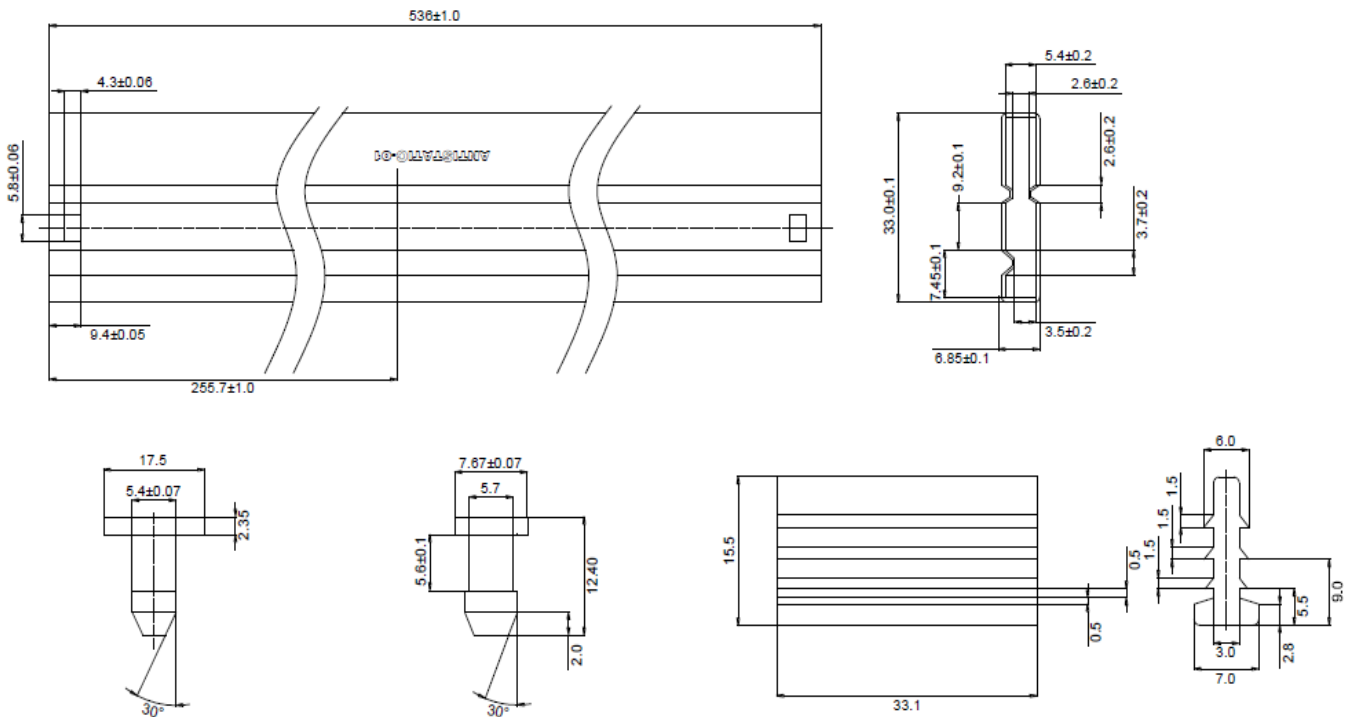

**P1650GTF**  
**N-Channel Enhancement Mode MOSFET**

**C. Lot No.&Date Code rule**

1. Lot No.

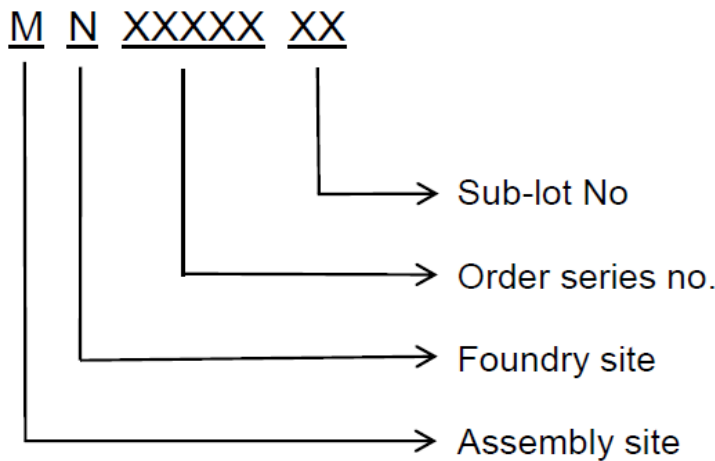

2. Date Code

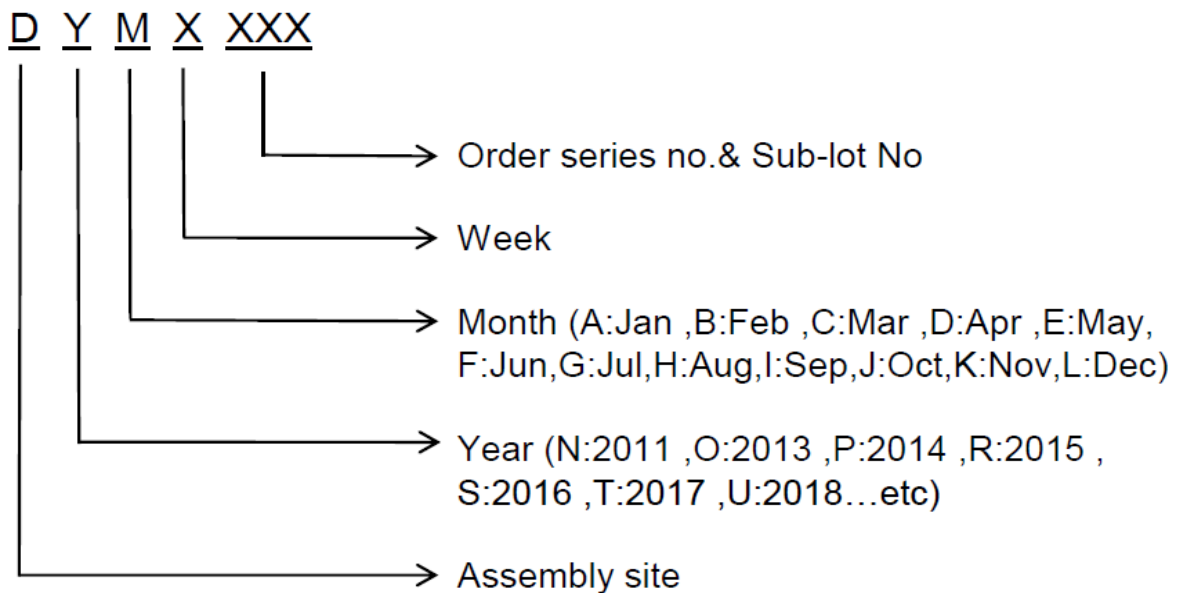



# P1650GTF

## N-Channel Enhancement Mode MOSFET

### D.Label rule

标签内容(Label content)



1	Label Size	30 * 90 mm
2	Font style	Times New Roman or Arial (或可区分英文"0"和数字"0", "G和"Q"的字型即可)
3	U-NIKC	Height: 4 mm
4	Package	Height: 2 mm
5	Date	Height: 2 mm Shipping date: YYYY/MM/DD, ex. 2008/09/12
6	Device	Height: 3 mm (Max: 16 Digit)
7	Lot	Height: 3 mm (Max: 9 Digit) Sub lot
8	D/C	Height: 3 mm (Max: 7 Digit)
9	QTY	Height: 3 mm (Max: 6 Digit) Thousand mark is no needed
10	RoHS label	 long axis: 12 mm      minor axis: 6 mm bottom color: White Font color: Black      Font style: Arial
11	Halogen Free label	 Diameter: 10 mm      bottom color: Green Font color: Black      Font style: Arial
12	Scan information	Device / Lot / D/C / QTY , Insert “ / “ between every parts. for example: P3055LDG/G12345601/GGG2301/2000 DPI (Dots per inch): Over 300 dpi Code : Code 128 Height: 6 mm at least