

Knob Potentiometer



FEATURES

- Test according to CECC 41000 or IEC 60393-1
- **P16F** - version for professional and industrial applications (cermet)
 - 1 W at 40 °C
- **PA16F** - version for professional audio applications (conductive plastic)
 - 0.5 W at 40 °C
- Compact (integrated)
- High dielectric strength: 5000 V_{AC}
- Fully sealed and panel sealed
- Metallic knob, special marking, or custom knob on request
- Custom knob and marking on request
- Material categorization: for definitions of compliance please see www.vishay.com/doc?99912

RoHS
COMPLIANT

LINKS TO ADDITIONAL RESOURCES



3D Models



Capabilities and Custom Options

The P16F is a revolutionary concept in panel mounted potentiometers. This unique design consists of a knob driving and incorporating a cermet potentiometer. Only the mounting hardware and terminals are situated on the back side of the panel reducing to a minimum the required clearance.

QUICK REFERENCE DATA

Multiple module	No
Switch module	Yes
Detent module	Yes
Special electrical laws	A: linear, L: logarithmic, F: reverse logarithmic
Sealing level	IP 67
Lifespan	10K cycles (switch), 50 cycles (track)

DIMENSIONS in millimeters (± 0.5 mm)

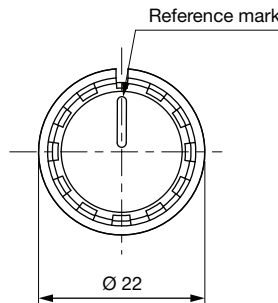
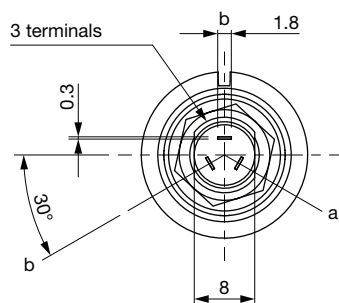
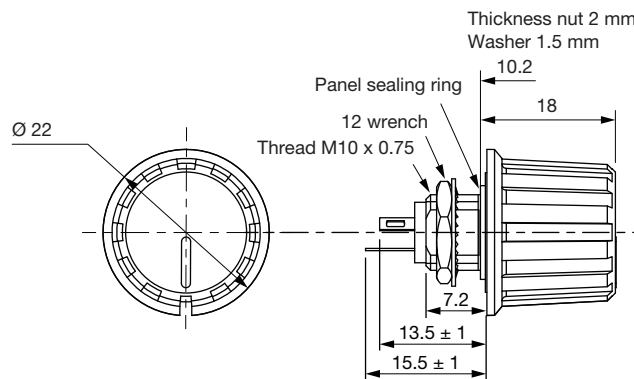

Panel Cutout

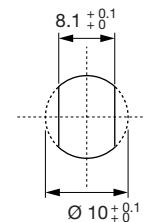

Panel thickness max.: 3 mm

ELECTRICAL SPECIFICATIONS			
	P16F	PA16F: VERSION FOR AUDIO PROFESSIONAL APPLICATION	
Resistive element	Cermet	Conductive plastic	
Electrical travel	$270^\circ \pm 10^\circ$	$270^\circ \pm 10^\circ$	
Power rating chart			
Circuit diagram			
Taper			
Resistance range	Linear taper Logarithmic taper	22 Ω to 10 M Ω 100 Ω to 2.2 M Ω	1 k Ω to 1 M Ω 470 Ω to 500 k Ω
Standard series E3		1 - 2.2 - 4.7 and on request 1 - 2 - 5	1 - 2.2 - 4.7
Tolerance	Standard On request	$\pm 20\%$ $\pm 10\%$	$\pm 20\%$ $\pm 10\%$ (1 k Ω to 100 k Ω)
Power rating	Linear Logarithmic	1 W at +40 $^\circ\text{C}$ 0.5 W at +40 $^\circ\text{C}$	0.5 W at +40 $^\circ\text{C}$ 0.25 W at +40 $^\circ\text{C}$
Temperature coefficient (typical)		± 150 ppm/ $^\circ\text{C}$	± 500 ppm/ $^\circ\text{C}$
Dielectric strength (RMS)		5000 V _{AC}	5000 V _{AC}
Limiting element voltage (linear law)		350 V	350 V
Contact resistance variation		3 % R _n or 3 Ω	2 % R _n or 3 Ω
End resistance (typical)		1 Ω	1 Ω
Insulation resistance (500 V _{DC})		10 ⁶ M Ω	10 ⁶ M Ω



MECHANICAL SPECIFICATIONS	
Mechanical travel	300° ± 5°
Operating torque	3 Ncm typical
End stop torque	25 Ncm maximum
Max. tightening torque of mounting nut	180 Ncm maximum
Unit Weight	4.5 g typical

ENVIRONMENTAL SPECIFICATIONS		
	METALLIC KNOB (on request)	PLASTIC KNOB
Temperature range	-40 °C to +125 °C	-40 °C to +85 °C
Climatic category	40 / 100 / 56	40 / 85 / 56
Sealing	Sealed container and panel sealed	
Protection grades	IP67	

MARKING
<ul style="list-style-type: none"> Ohmic value code, tolerance code and taper Manufacturing date code

CONTROL KNOB
Black metallic knob (NM). On request, please consult Vishay. Black plastic knob (NP).

PACKAGING
<ul style="list-style-type: none"> Carton box of 20 pieces
Hardware: nuts, washer, and O-ring are separately supplied (not mounted on the potentiometer), in a small bag placed in the packaging.

SWITCH OPTION		
ON / OFF switch	Actuation in counter clockwise between terminal a and terminal b	
Switching current	P16F	100 mA max.
	P16AF, version for audio professional application	1 mA max.
Switching actuation torque	3 Ncm typical	
Switching actuation travel	30° ± 5°	
Dielectric strength terminal to terminal (RMS)	1000 V	
Insulation resistance between contacts	10 ⁶ MΩ	
Switch mechanical endurance	10 000 cycles	
1 cycle	ON - OFF - ON	
Ordering information (special code)	RSD	

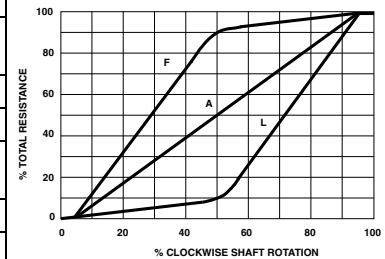

KNOB MARKING OPTIONS		
SPECIAL NUMBER	MARKING	EXAMPLE IMAGES
On request: several marking options on the top face of the knob		
F2	10 graduations	
F3	5 graduations	
F4	Gradient	
F5	Light	
F6	Fan	
F7	Temperature	
F8	Volume	
(Special code)	Other on demand	

P16F STANDARD RESISTANCE ELEMENT DATA						
STAN- DARD RESIS- TANCE VALUES	LINEAR TAPER			LOG TAPER		
	MAX. POWER AT 40 °C	MAX. VOLTAGE	MAX. CUR. THROUGH WIPER	MAX. POWER AT 40 °C	MAX. VOLTAGE	MAX. CUR. THROUGH WIPER
	Ω	W	V	mA	W	V
22	1	4.69	213			
47	1	6.85	146			
100	1	10	100			
220	1	14.8	67.4	0.5	7.1	71
470	1	21.7	46.1	0.5	10.5	48
1K	1	31.6	31.6	0.5	15.3	32.6
2.2K	1	46.9	21.3	0.5	22.4	22.4
4.7K	1	68.5	14.6	0.5	33.2	15.1
10K	1	100	10	0.5	48.5	10.3
22K	1	148	6.74	0.5	70.7	7.07
47K	1	217	4.61	0.5	105	4.77
100K	1	316	3.16	0.5	153	3.26
220K	0.56	350	1.59	0.5	224	2.24
470K	0.26	350	0.75	0.5	332	1.51
1M	0.12	350	0.35	0.26	350	0.74
2.2M	0.05	350	0.16	0.12	350	0.35
4.7M	0.02	350	0.07	0.056	350	0.16
10M	0.01	350	0.012			

PA16F STANDARD RESISTANCE ELEMENT						
STAN- DARD RESIS- TANCE VALUES	LINEAR TAPER			LOG TAPER		
	MAX. POWER AT 40 °C	MAX. VOLTAGE	MAX. CUR. THROUGH WIPER	MAX. POWER AT 40 °C	MAX. VOLTAGE	MAX. CUR. THROUGH WIPER
	Ω	W	V	mA	W	V
470						
1K	0.5	22.4	22.4	0.25	10.8	23.1
2.2K	0.5	33.2	15.1	0.25	15.8	16
4.7K	0.5	48.5	10.3	0.25	23.5	11
10K	0.5	70.7	7.07	0.25	34.3	7
22K	0.5	105	4.77	0.25	50.0	5.0
47K	0.5	153	3.26	0.25	74	3.4
100K	0.5	224	2.24	0.25	108	2.3
220K	0.5	332	1.51	0.25	158	1.6
470K	0.26	350	0.74	0.25	235	1.1
1M	0.12	350	0.35	0.25	343	0.7

DETENT OPTION
On request: The detent mechanism is housed in the P16 One detent at CCW position Mechanical endurance: 10 000 cycles Ordering information (special code): CV1D: one detent at CCW position (on request)



PERFORMANCE				
TESTS	CONDITIONS	TYPICAL VALUES AND DRIFTS		
		$\Delta R_T/R_T$ (%)	$\Delta R_{1-2}/R_{1-2}$ (%)	OTHER
Electrical endurance	1000 h at rated power 90°/30° cycle at +40 °C	± 5 %	-	Insulation resistance: > 10 ⁴ MΩ Contact res. variation: < 2 % Rn
Damp heat, steady state	56 days 40 °C, 93 % HR	± 2 %	± 1 %	Insulation resistance: > 10 ⁴ MΩ
Mechanical endurance	50 000 cycles	± 5 %	-	Contact res. variation: < 2 % Rn
Shock	50 g's at 11 ms 3 successive shocks in 3 directions	± 0.2 %	± 0.5 %	-
Vibration	10 Hz to 55 Hz 0.75 mm or 10 g's during 6 h	± 0.2 %	-	$\Delta V_{1-2}/\Delta V_{1-3} \leq \pm 0.5 \%$

Note

- Nothing stated herein shall be construed as a guarantee of quality or durability

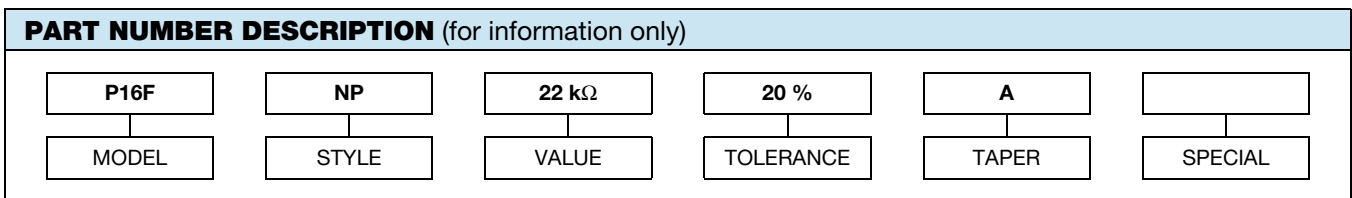
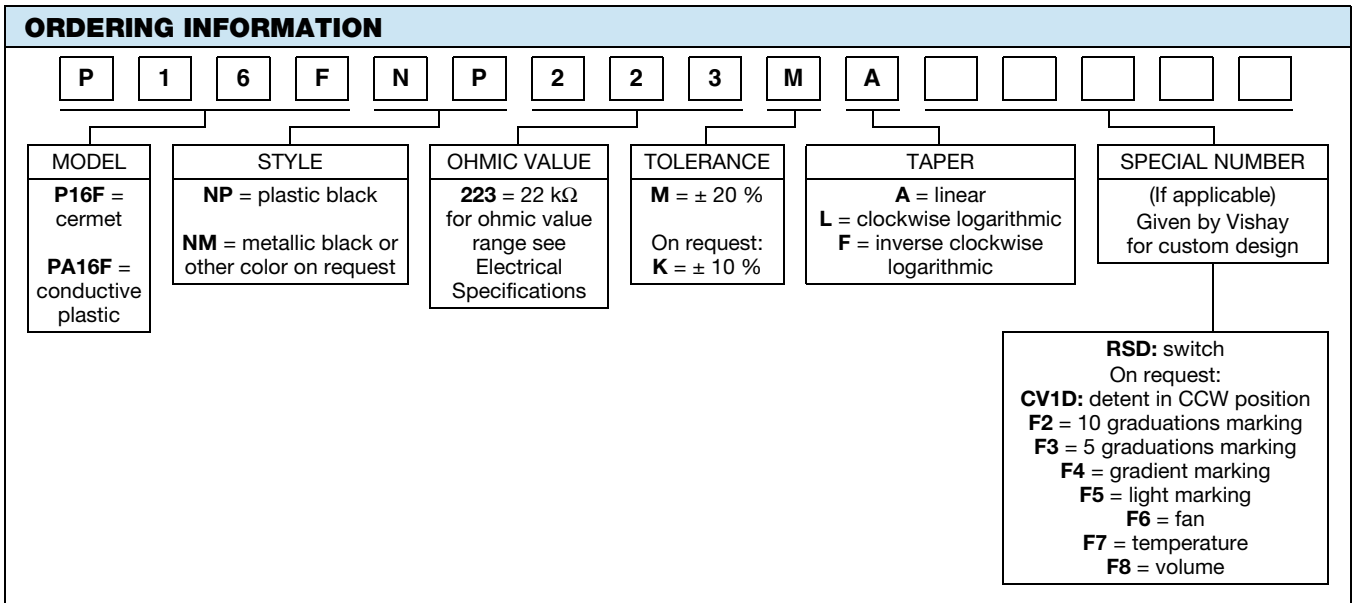

RELATED DOCUMENTS	
APPLICATION NOTES	
Potentiometers and Trimmers	www.vishay.com/doc?51001
Guidelines for Vishay Sfernice Resistive and Inductive Components	www.vishay.com/doc?52029
Capabilities and Custom Options	www.vishay.com/doc?48493



Disclaimer

ALL PRODUCT, PRODUCT SPECIFICATIONS AND DATA ARE SUBJECT TO CHANGE WITHOUT NOTICE TO IMPROVE RELIABILITY, FUNCTION OR DESIGN OR OTHERWISE.

Vishay Intertechnology, Inc., its affiliates, agents, and employees, and all persons acting on its or their behalf (collectively, "Vishay"), disclaim any and all liability for any errors, inaccuracies or incompleteness contained in any datasheet or in any other disclosure relating to any product.

Vishay makes no warranty, representation or guarantee regarding the suitability of the products for any particular purpose or the continuing production of any product. To the maximum extent permitted by applicable law, Vishay disclaims (i) any and all liability arising out of the application or use of any product, (ii) any and all liability, including without limitation special, consequential or incidental damages, and (iii) any and all implied warranties, including warranties of fitness for particular purpose, non-infringement and merchantability.

Statements regarding the suitability of products for certain types of applications are based on Vishay's knowledge of typical requirements that are often placed on Vishay products in generic applications. Such statements are not binding statements about the suitability of products for a particular application. It is the customer's responsibility to validate that a particular product with the properties described in the product specification is suitable for use in a particular application. Parameters provided in datasheets and / or specifications may vary in different applications and performance may vary over time. All operating parameters, including typical parameters, must be validated for each customer application by the customer's technical experts. Product specifications do not expand or otherwise modify Vishay's terms and conditions of purchase, including but not limited to the warranty expressed therein.

Hyperlinks included in this datasheet may direct users to third-party websites. These links are provided as a convenience and for informational purposes only. Inclusion of these hyperlinks does not constitute an endorsement or an approval by Vishay of any of the products, services or opinions of the corporation, organization or individual associated with the third-party website. Vishay disclaims any and all liability and bears no responsibility for the accuracy, legality or content of the third-party website or for that of subsequent links.

Except as expressly indicated in writing, Vishay products are not designed for use in medical, life-saving, or life-sustaining applications or for any other application in which the failure of the Vishay product could result in personal injury or death. Customers using or selling Vishay products not expressly indicated for use in such applications do so at their own risk. Please contact authorized Vishay personnel to obtain written terms and conditions regarding products designed for such applications.

No license, express or implied, by estoppel or otherwise, to any intellectual property rights is granted by this document or by any conduct of Vishay. Product names and markings noted herein may be trademarks of their respective owners.