

Thyristor Surge Suppressors

P0060~P3500EA_B_C Serie

Description

P0060~P3500EA_B_C Serie are designed to protect baseband equipment such as modems, line cards, CPE and DSL from damaging overvoltage transients. The series provides a robust through-hole solution that enables equipment to comply with global regulatory standards.



Features and Benefits

- Low voltagr overshoot
- Low on-state voltage
- Does not degrade with use
- Fails short circuit when surged in excess of ratings
- Low Capacitance

Applicable Global Standards

- TIA-968-A
- ITU K.20/21 Enhanced level*
- ITU K.20/21 Basic Level
- GR 1089 Inter building*
- GR 1089 Inter building
- IEC 6100-4-5
- YD/T 1082
- YD/T 993
- YD/T 950

Product Name

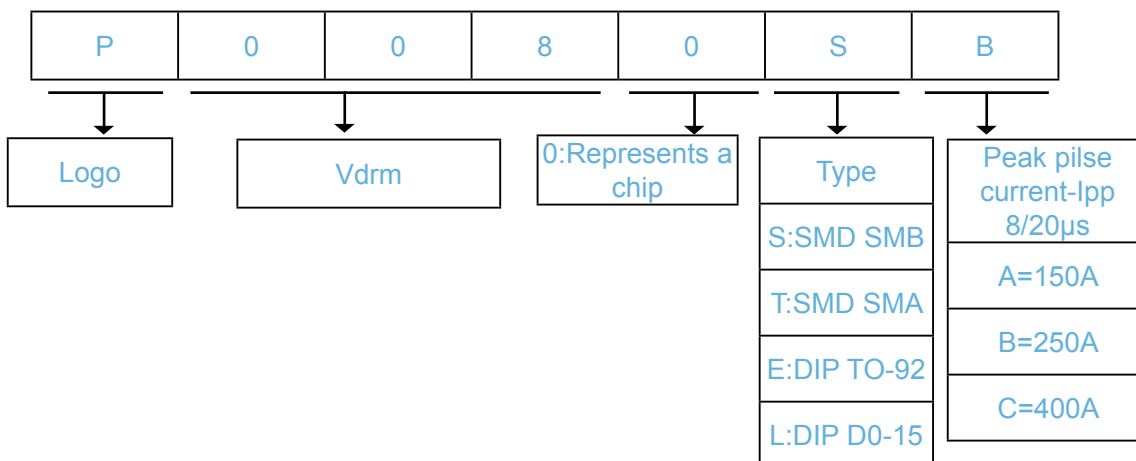

Electrical Characteristics (@ TA = 25 °C Unless Otherwise Noted)

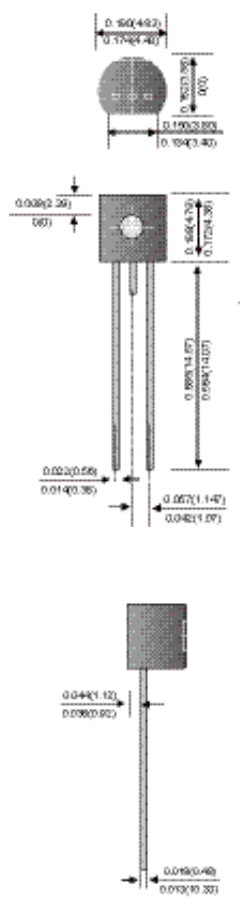
Type Number	V _{DRM}	I _{DRM}	V _{BO}	I _H	I _S	I _T	V _T	C _J		Package Dimensions inch(mm)
	V	μA	V	MA	MA	A	V	pF _{Min}	pF _{Max}	
P0080EA	6	5	25	50	800	2.2	4	25	150	 <p style="text-align: right; margin-top: 10px;">TO-92</p>
P0080EB	6	5	25	50	800	2.2	4	25	150	
P0080EC	6	5	25	50	800	2.2	4	35	260	
P0300EA	25	5	40	50	800	2.2	4	15	140	
P0300EB	25	5	40	50	800	2.2	4	15	140	
P0300EC	25	5	40	50	800	2.2	4	25	250	
P0640EA	58	5	77	150	800	2.2	4	40	60	
P0640EB	58	5	77	150	800	2.2	4	40	60	
P0640EC	58	5	77	150	800	2.2	4	55	155	
P0720EA	65	5	88	150	800	2.2	4	35	60	
P0720EB	65	5	88	150	800	2.2	4	35	75	
P0720EC	65	5	88	150	800	2.2	4	50	150	
P0900EA	75	5	98	150	800	2.2	4	35	55	
P0900EB	75	5	98	150	800	2.2	4	35	70	
P0900EC	75	5	98	150	800	2.2	4	45	140	
P1100EA	90	5	130	150	800	2.2	4	30	50	
P1100EB	90	5	130	150	800	2.2	4	30	70	
P1100EC	90	5	130	150	800	2.2	4	45	115	
P1300EA	120	5	160	150	800	2.2	4	25	45	
P1300EB	120	5	160	150	800	2.2	4	25	60	
P1300EC	120	5	160	150	800	2.2	4	40	105	
P1500EA	140	5	180	150	800	2.2	4	25	40	
P1500EB	140	5	180	150	800	2.2	4	25	55	
P1500EC	140	5	180	150	800	2.2	4	35	95	
P1800EA	170	5	220	150	800	2.2	4	25	35	
P1800EB	170	5	220	150	800	2.2	4	25	50	
P1800EC	170	5	220	150	800	2.2	4	35	90	
P2300EA	190	5	260	150	800	2.2	4	25	35	
P2300EB	190	5	260	150	800	2.2	4	25	50	
P2300EC	190	5	260	150	800	2.2	4	30	80	
P2600EA	220	5	300	150	800	2.2	4	20	35	
P2600EB	220	5	300	150	800	2.2	4	20	45	
P2600EC	220	5	300	150	800	2.2	4	30	80	
P3100EA	275	5	350	150	800	2.2	4	20	35	
P3100EB	275	5	350	150	800	2.2	4	20	45	
P3100EC	275	5	350	150	800	2.2	4	30	70	
P3500EA	320	5	400	150	800	2.2	4	20	35	
P3500EB	320	5	400	150	800	2.2	4	20	40	
P3500EC	320	5	400	150	800	2.2	4	25	65	

Notes:
 - Absolute maximum ratings measured at TA= 25°C (unless otherwise noted).
 - Devices are bi-directional.

SERIES	Peak Pulse Current-Ipp(A)				
	2/10μs	8/20μs	10/160μs	10/560μs	10/1000μs
A	200	150	100	60	50
B	250	250	150	100	80
C	500	400	200	120	100

Surge Ratings

Series	I_{PP}									I_{TSM} 50/60 Hz	di/dt
	0.2x310 ¹ 0.5x700 ²	2x10 ¹ 2x10 ²	8x20 ¹ 1.2x50 ²	10x160 ¹ 10x160 ²	10x560 ¹ 10x560 ²	5x320 ¹ 9x720 ²	10x360 ¹ 10x360 ²	10x1000 ¹ 10x1000 ²	5x310 ¹ 10x700 ²		
	A min	A min	A min	A min	A min	A min	A min	A min	A min		
A	20	150	150	90	50	75	75	45	75	20	500
B	25	250	250	150	100	100	125	80	100	25	500
C	50	500	400	200	150	200	175	100	200	30	500

Notes:

- 1 Current waveform in μs
- 2 Voltage waveform in μs
- Peak pulse current rating (I_{PP}) is repetitive and guaranteed for the life of the product.
- I_{PP} ratings applicable over temperature range of $-40^{\circ}C$ to $+85^{\circ}C$
- The device must initially be in thermal equilibrium with $-40^{\circ}C \leq T_J \leq +150^{\circ}C$

Thermal Considerations

Package	Symbol	Parameter	Value	Unit
TO-92 	T_J	Operating Junction Temperature Range	-40 to +150	$^{\circ}C$
	T_S	Storage Temperature Range	-65 to +150	$^{\circ}C$
	$R_{\theta JA}$	Thermal Resistance: Junction to Ambient	90	$^{\circ}C/W$

Packing Options

Package Type	Description	Packing Options Quantity	Added Suffix	Lead Spacing	Industry Standard
E	TO-92 Tape and Reel Pack	1000	RP1	0.1 inch (2.54mm)	EIA-481-D
			RP2	0.2 inch (5.08mm)	
	TO-92 Ammo Pack		AP		EIA-468-B
	TO-92 Bulk Pack		N/A		N/A

Current Energy and Power Dissipation Ratings

Should transients occur in rapid succession, the average power dissipation is the energy (watt-seconds) per pulse times the number of pulses per second. The power so developed must be within the specifications shown on the Device Ratings and Specifications Table for the specific

device. The operating values of a MOV need to be derated at high temperatures as shown above. Because varistors only dissipate a relatively small amount of average power they are not suitable for repetitive applications that involve substantial amounts of average power dissipation.

Figure 1A - Power Derating for Epoxy Coated

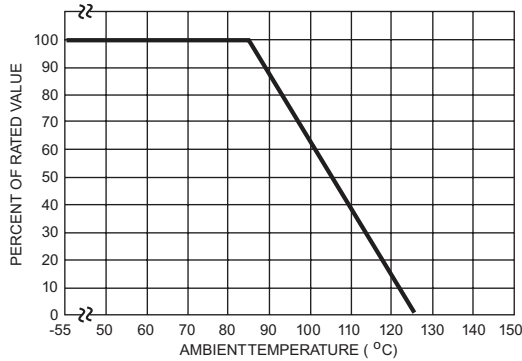
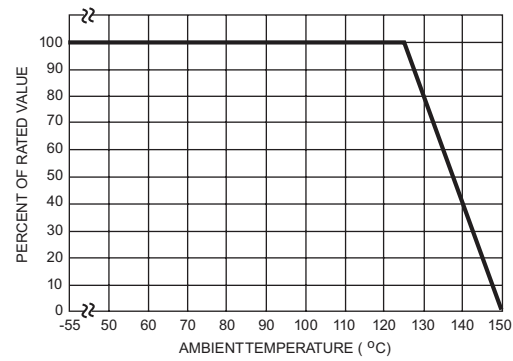

Figure 1B - Power Derating for Pholenic Coated



Peak Pulse Current Test Waveform

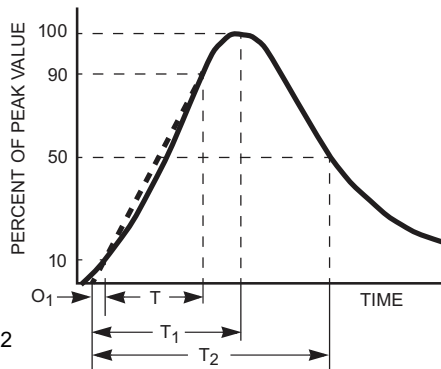

Figure 2

O_1 = Virtual Origin of Wave
 T = Time from 10% to 90% of Peak
 T_1 = Rise Time = $1.25 \times T$
 T_2 = Decay Time

Example - For an $8/20 \mu\text{s}$ Current Waveform:

$8\mu\text{s} = T_1 = \text{Rise Time}$
 $20\mu\text{s} = T_2 = \text{Decay Time}$

Physical Specifications

Lead Material	Copper Alloy
Terminal Finish	100% Matte-Tin Plated
Body Material	UL recognized epoxy meeting flammability classification 94V-0

Environmental Specifications

High Temp Voltage Blocking	80% Rated V_{DRM} ($V_{\text{AC Peak}}$) +125°C or +150°C, 504 or 1008 hrs. MIL-STD-750 (Method 1040) JEDEC, JESD22-A-101
Temp Cycling	-65°C to +150°C, 15 min. dwell, 10 up to 100 cycles. MIL-STD-750 (Method 1051) EIA/JEDEC, JESD22-A-104
Biased Temp & Humidity	52 V_{DC} (+85°C) 85%RH, 504 up to 1008 hrs. EIA/JEDEC, JESD22-A-101
High Temp Storage	+150°C 1008 hrs. MIL-STD-750 (Method 1031) JEDEC, JESD22-A-101
Low Temp Storage	-65°C, 1008 hrs.
Thermal Shock	0°C to +100°C, 5 min. dwell, 10 sec. transfer, 10 cycles. MIL-STD-750 (Method 1056) JEDEC, JESD22-A-106
Autoclave (Pressure Cooker Test)	+121°C, 100%RH, 2atm, 24 up to 168 hrs. EIA/JEDEC, JESD22-A-102
Resistance to Solder Heat	+260°C, 30 secs. MIL-STD-750 (Method 2031)

Figure 1.E examples of protection stages for line cards

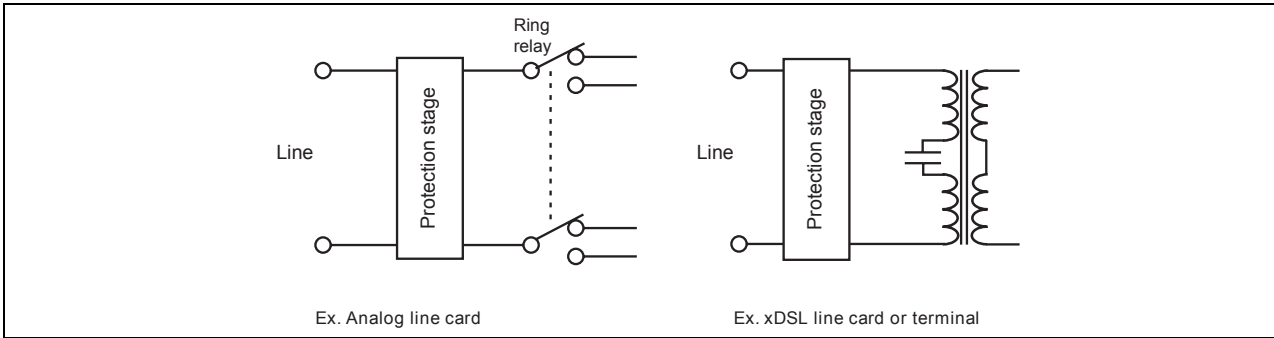

In such a stage, parallel function is assumed by one or several Trisil, and is used to protect against short duration surge (lightning). During this kind of surges the Trisil limits the voltage across the device to be protected at its break over value and then fires. The fuse assumes the series function, and is used to protect the module against long duration or very high current mains disturbances (50/60Hz). It acts by safe circuit opening. Lightning surge and mains disturbance surges are defined by standards like GR1089, FCC part 68, ITU-T K20.

Figure 2. Typical circuits

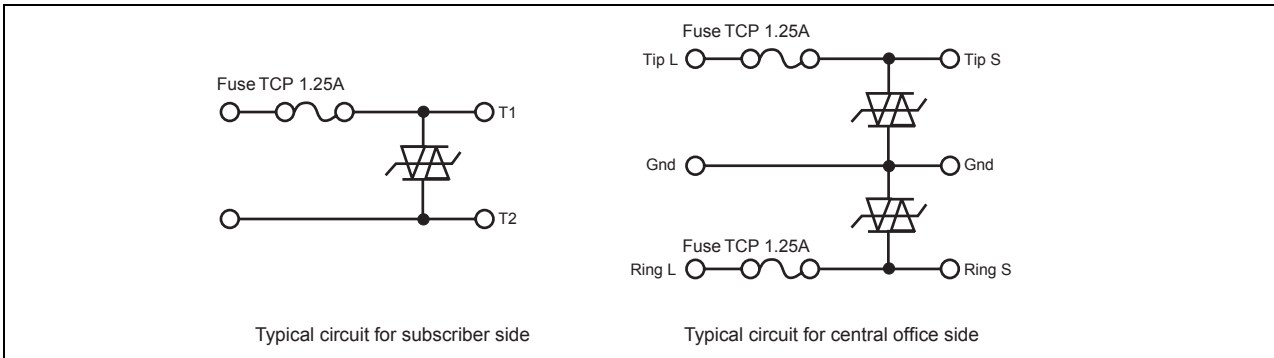

Figure 3.T test circuit 1 for Dynamic I_{BO} and V_{BO} parameters

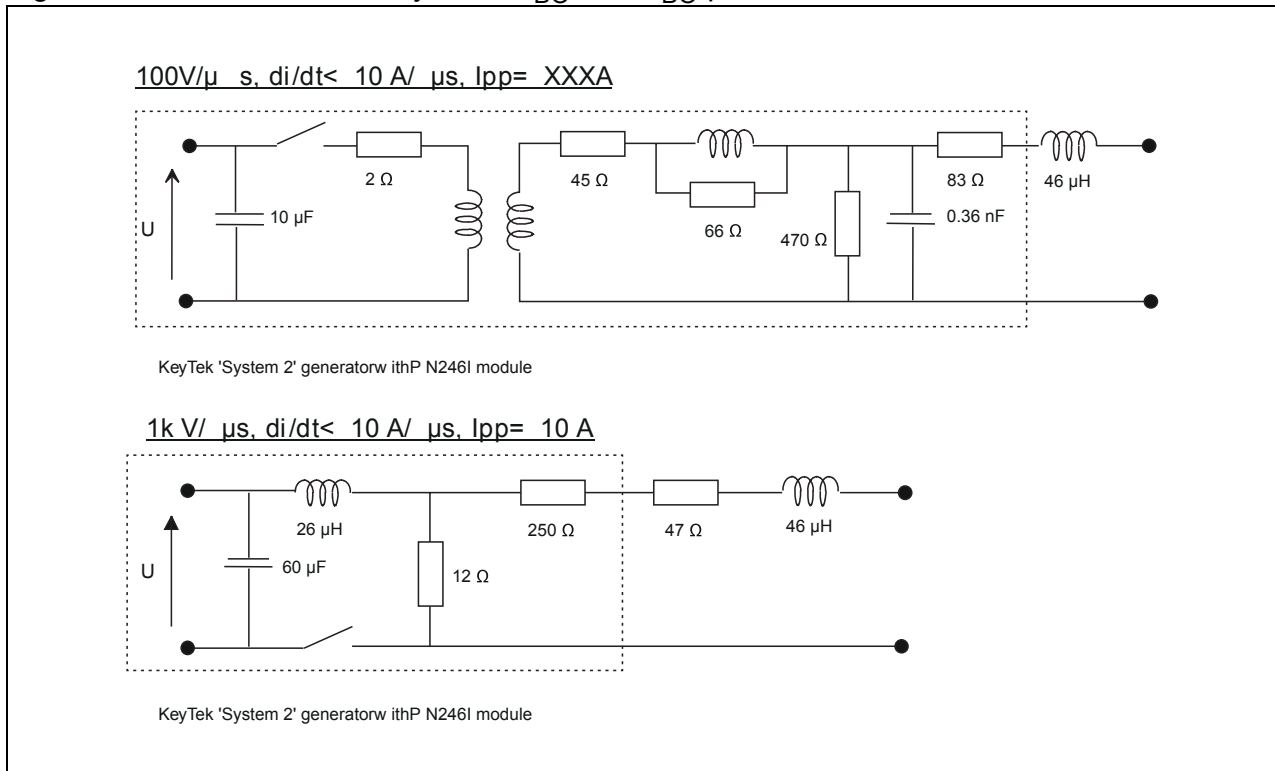

Figure 5. Test circuit 3 for dynamic I_H parameter

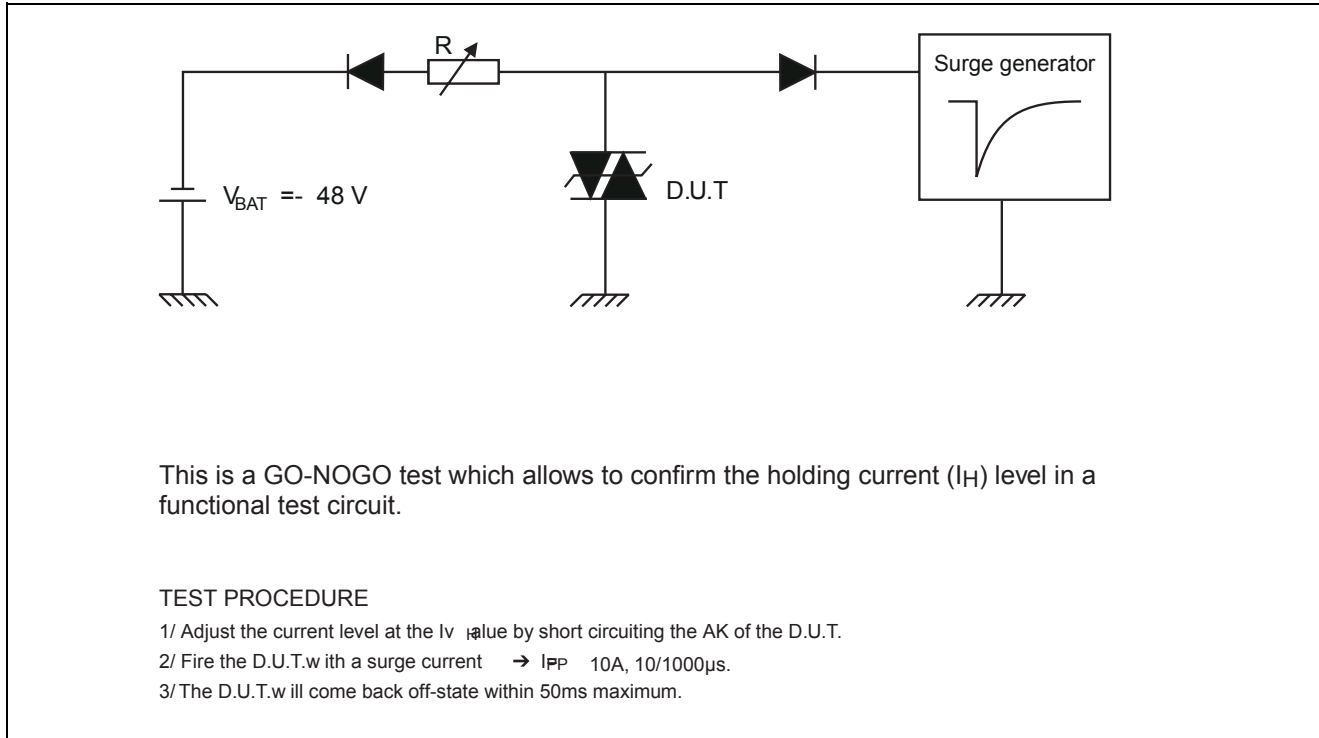
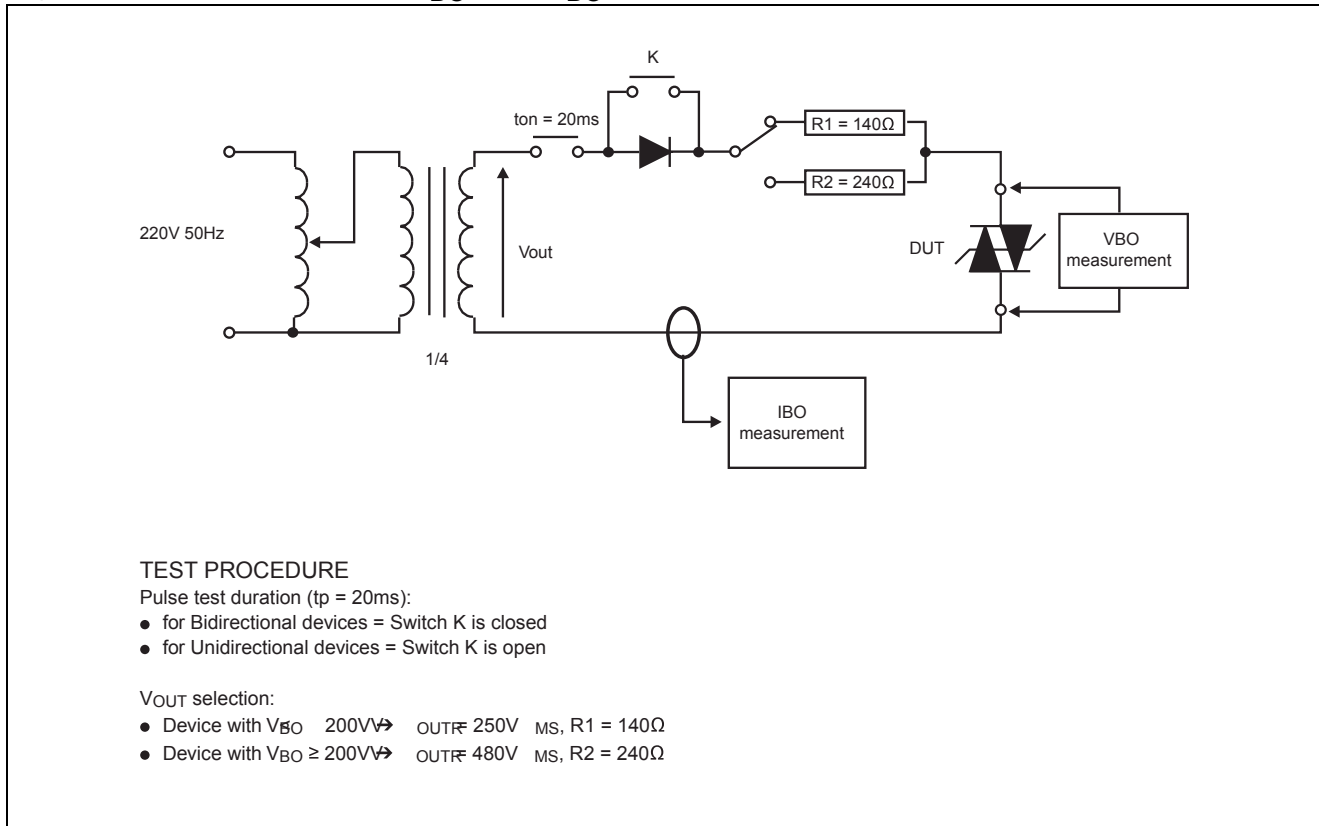
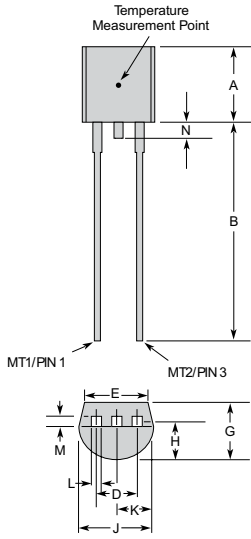

Figure 4. Test circuit 2 for I_{BO} and V_{BO} parameters



Dimensions — TO-92



	Inches		Millimeters	
	Min	Max	Min	Max
A	0.176	0.196	4.47	4.98
B	0.500		12.70	
D	0.095	0.105	2.41	2.67
E	0.150		3.81	
G	0.135	0.145	3.43	3.68
H	0.088	0.096	2.23	2.44
J	0.176	0.186	4.47	4.73
K	0.088	0.096	2.23	2.44
L	0.013	0.019	0.33	0.48
M	0.013	0.017	0.33	0.43
N		0.60		1.52

All leads are insulated from case. Case is electrically non-conductive. (Rated at 1600 V_{ACI} RMS for one minute from leads to case over the operating temperature range.)

Mold flash shall not exceed 0.13 mm per side.

The TO-92 is designed to meet mechanical standards as set forth in JEDEC publication number 95.

Ammo Pack Specification — TO-92

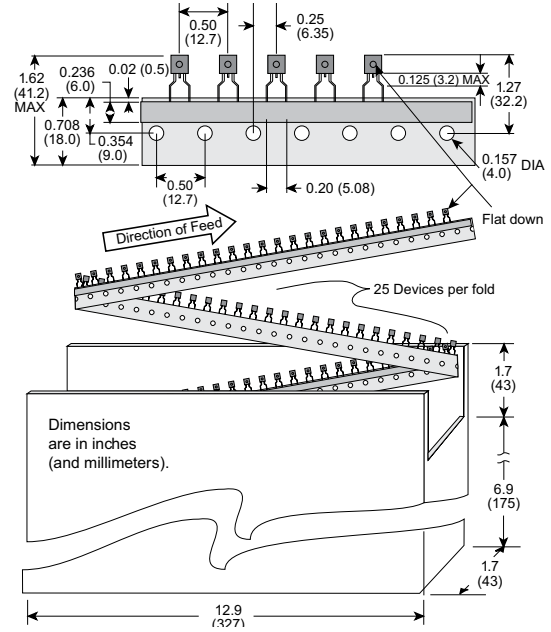

Tape and Reel Specification — TO-92

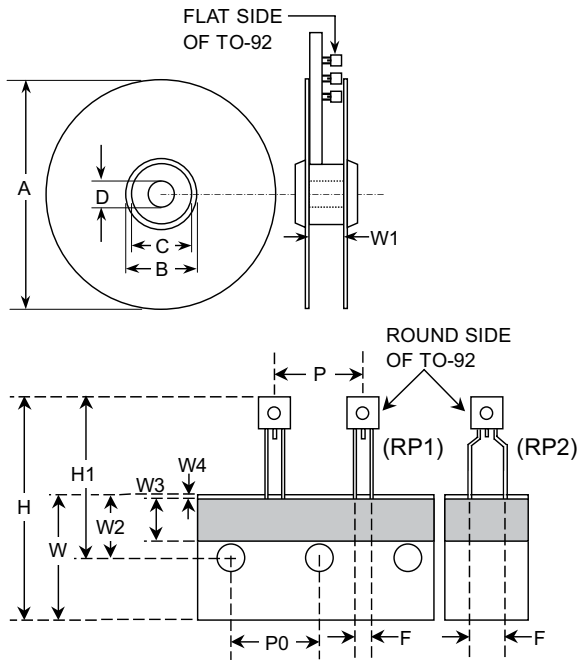

Dimensions	Inches		Millimeters	
	Min	Max	Min	Max
A	N/A	14.173	N/A	360.0
B	4.016	N/A	102.0	N/A
C	3.386	N/A	86.0	N/A
D	0.795	N/A	20.2	N/A
W1	1.181	1.968	30.0	50.0
P	0.496	0.504	12.60	12.80
P0	0.498	0.502	12.65	12.75
F(for RP1)	0.090	0.110	2.29	2.80
F(for RP2)	0.182	0.244	4.63	6.19
H	N/A	1.673	N/A	42.50
H1	N/A	1.270	N/A	32.26
W	0.674	0.763	17.12	19.38
W2	0.354	0.370	8.25	9.75
W3	0.236	N/A	6.00	N/A
W4	0.020	N/A	0.50	N/A

RUILONG.YUAN CO.,LTD
Tel: +86- 0755-82908296
Fax: +86- 0755-82908002

Email: jack@ruilon.com
Website: <http://www.ruilon.com>

RuiLongYuan Electronics are trademarks.

Information furnished is believed to be accurate and reliable. However, users should independently evaluate the suitability of and test each product selected for their own applications. RUILONYUAN Electronics reserves the right to change or update, without notice, any information contained in this publication; to change, without notice, the design, construction, processing, or specification of any product; and to discontinue or limit production or distribution of any product. This publication supersedes and replaces all information previously supplied. Without expressed or written consent by an officer of RUILONYUAN Electronics, RUILONYUAN Electronics does not authorize the use of any of its products as components in nuclear facility applications, aerospace, or in critical life support devices or systems. RUILONYUAN Electronics expressly disclaims all implied warranties regarding the information contained herein, including, but not limited to, any implied warranties of merchantability or fitness for a particular purpose. RUILONYUAN Electronics' only obligations are those in the RUILONYUAN Electronics Standard Terms and Conditions of Sale and in no case will RUILONYUAN Electronics be liable for any incidental, indirect, or consequential damages.