

P2010A

Low Frequency EMI Reduction IC

Description

The P2010A is a selectable spread spectrum frequency modulator designed specifically for PC peripheral and embedded controller markets. The P2010A reduces electromagnetic interference (EMI) at the clock source which provides system wide reduction of EMI of all clock dependent signals. The P2010A allows significant system cost savings by reducing the number of circuit board layers and shielding that are traditionally required to pass EMI regulations.

The P2010A uses the most efficient and optimized modulation profile approved by the FCC and is implemented in a proprietary all-digital method.

The P2010A modulates the output of a single PLL in order to “spread” the bandwidth of a synthesized clock and, more importantly, decreases the peak amplitudes of its harmonics. This results in significantly lower system EMI compared to the typical narrow band signal produced by oscillators and most frequency generators. Lowering EMI by increasing a signal’s bandwidth is called ‘spread spectrum clock generation.’

Applications

The P2010A is targeted towards the embedded controller market and PC peripheral markets including scanners, facsimile, MFP’s, printers, PDA, IA, and GPS devices.

Features

- FCC Approved Method of EMI Attenuation
- Provides up to 20 dB of EMI Suppression
- Generates a Low EMI Spread Spectrum Clock of the Input Frequency
- Optimized for 10 MHz to 35 MHz Input Frequency Range
- Internal Loop Filter Minimizes External Components and Board Space
- 4 Selectable Spread Ranges
- SSON Control Pin for Spread Spectrum Enable and Disable Options
- Low Cycle-to-Cycle Jitter
- Wide Operating Range (3 V to 5 V)
- 16 mA Output Drives
- TTL or CMOS Compatible Outputs
- Low Power CMOS Design
- Available in 8-pin SOIC and TSSOP Packages
- These are Pb-Free Devices



ON Semiconductor®

<http://onsemi.com>



**SOIC-8
S SUFFIX
CASE 751BD**



**TSSOP-8
T SUFFIX
CASE 948AL**

PIN CONFIGURATION

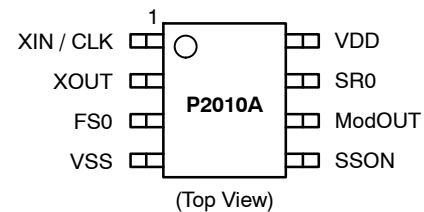

ORDERING INFORMATION

See detailed ordering and shipping information in the package dimensions section on page 7 of this data sheet.

P2010A

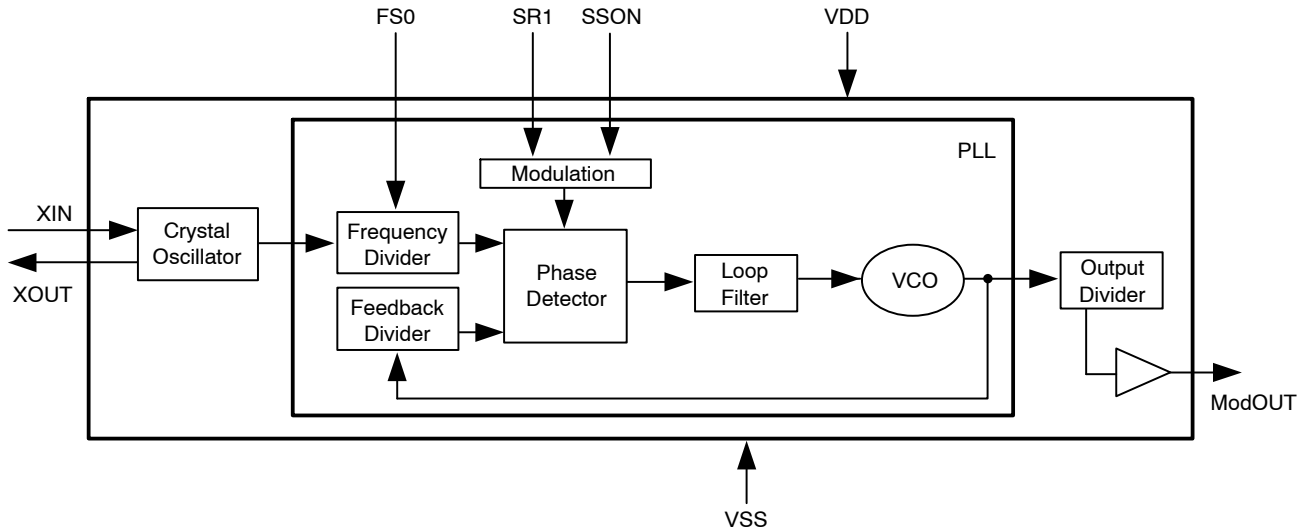

Figure 1. Block Diagram

Table 1. ABSOLUTE MAXIMUM RATINGS

Symbol	Parameter	Rating	Unit
V_{DD}, V_{IN}	Voltage on any pin with respect to Ground	-0.5 to +7	V
T_{STG}	Storage temperature	-65 to +125	°C
T_A	Operating temperature	-40 to +85	°C
T_s	Max. Soldering Temperature (10 sec)	260	°C
T_J	Junction Temperature	150	°C
T_{DV}	Static Discharge Voltage (As per JEDEC STD22- A114-B)	2	KV

Stresses exceeding Maximum Ratings may damage the device. Maximum Ratings are stress ratings only. Functional operation above the Recommended Operating Conditions is not implied. Extended exposure to stresses above the Recommended Operating Conditions may affect device reliability.

Table 2. DC ELECTRICAL CHARACTERISTICS

Symbol	Parameter	Min	Typ	Max	Unit
V_{IL}	Input Low Voltage	GND	-	0.8	V
V_{IH}	Input High Voltage	2.0	-	$V_{DD}+0.3$	V
I_{IL}	Input Low Current (pull-up resistor on inputs SR0, FS0)	-	-	-35	μA
I_{IH}	Input High Current (pull-down resistor on input SSON)	-	-	35	μA
I_{XOL}	XOUT Output Low Current (@ 0.4 V, $V_{DD} = 3.3$ V)	-	3	-	mA
I_{XOH}	XOUT Output High Current (@ 2.5 V, $V_{DD} = 3.3$ V)	-	3	-	mA
V_{OL}	Output Low Voltage ($V_{DD} = 3.3$ V, $I_{OL} = 20$ mA)	-	-	0.4	V
V_{OH}	Output High Voltage ($V_{DD} = 3.3$ V, $I_{OH} = 20$ mA)	2.5	-	-	V
I_{DD}	Static Supply Current	-	0.6	-	mA
I_{CC}	Dynamic Supply Current (3.3 V and 15 pF loading)	4	6	8	mA
VDD	Operating Voltage	2.7	3.3	5.5	V
t_{ON}	Power Up Time (First locked clock cycle after power up)	-	0.18	-	mS
Z_{OUT}	Clock Output Impedance	-	50	-	Ω

P2010A

Table 3. AC ELECTRICAL CHARACTERISTICS

Symbol	Parameter	Min	Typ	Max	Unit
f_{IN}	Input Frequency	10	20	35	MHz
t_{LH} (Note 1)	Output rise time (measured at 0.8 V to 2.0 V)	0.7	0.9	1.1	nS
t_{HL} (Note 1)	Output fall time (measured at 2.0 V to 0.8 V)	0.6	0.8	1.0	nS
t_{JC}	Jitter (Cycle-to-cycle)	-	-	360	pS
t_D	Output duty cycle	45	50	55	%

1. t_{LH} and t_{HL} are measured into a capacitive load of 15 pF.

Table 4. PIN DESCRIPTION

Pin#	Pin Name	Type	Description
1	XIN / CLK	I	Connect to crystal or externally generated clock signal.
2	XOUT	I	Connect to crystal. No connect if externally generated clock signal is used.
3	FS0	I	Digital logic input used to select Input Frequency Range (see Table 5). This pin has an internal pull-up resistor.
4	VSS	P	Ground Connection. Connect to system ground.
5	SSON	I	Digital logic input used to enable Spread Spectrum function (Active Low). Spread Spectrum function enable when low. This pin has an internal pull-low resistor.
6	ModOUT	O	Spread Spectrum Clock Output.
7	SR0	I	Digital logic input used to select Spreading Range (see Table 5). This pin has an internal pull-up resistor.
8	VDD	P	Connect to +3.3 V or +5.0 V.

Table 5. SPREAD RANGE SELECTION

FS0	SR0	Spreading Range	Input Frequency	Modulation Rate
1	0	$\pm 1.50\%$	10 MHz to 20 MHz	$(F_{in}/10) * 20.83$ KHz
1	1	$\pm 2.50\%$	10 MHz to 20 MHz	$(F_{in}/10) * 20.83$ KHz
0	0	$\pm 1.25\%$	20 MHz to 35 MHz	$(F_{in}/10) * 20.83$ KHz
0	1	$\pm 2.00\%$	20 MHz to 35 MHz	$(F_{in}/10) * 20.83$ KHz

P2010A

Spread Spectrum Selection

Table 5 illustrates the possible spread spectrum options. The optimal setting should minimize system EMI to the fullest without affecting system performance. The spreading is described as a percentage deviation of the center frequency.

(Note: The center frequency is the frequency of the external reference input on XIN / CLK, Pin 1).

Example of a Typical Printer or Scanner Application that Operates on a Clock Frequency of 16 MHz:

A spreading selection of FS0=1 and SR0=1 provides a percentage deviation of $\pm 2.50\%$ * (see Table 5) of Center Frequency. This results in the frequency on ModOUT being swept from 16.40 MHz to 15.60 MHz at a modulation rate of 33.33 KHz (see Table 5). This particular example (see Figure 2 below) given here is a common EMI reduction method for scanner, printer or embedded applications and has already been adopted by most of the leading manufacturers.

NOTE: Spreading range selection varies from different system manufacturers and their designs.

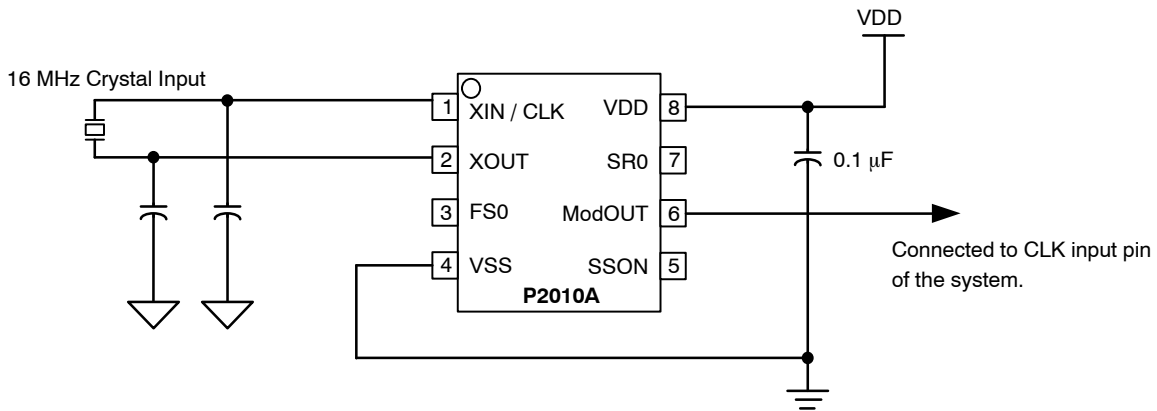
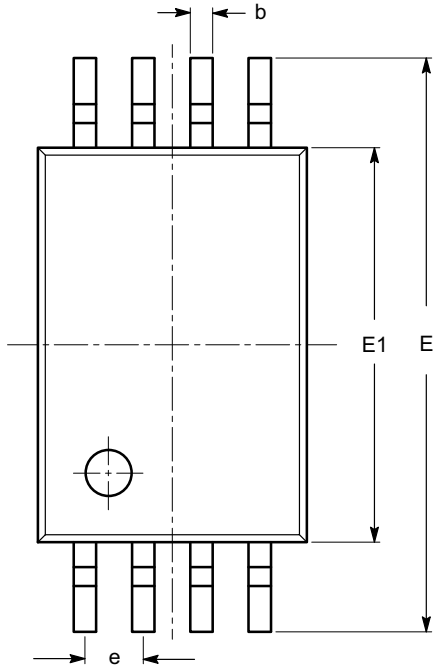

Figure 2. P2010A Application Schematic for Flat-Bed Scanner

P2010A

PACKAGE DIMENSIONS

TSSOP8, 4.4x3
CASE 948AL-01
ISSUE O



SYMBOL	MIN	NOM	MAX
A			1.20
A1	0.05		0.15
A2	0.80	0.90	1.05
b	0.19		0.30
c	0.09		0.20
D	2.90	3.00	3.10
E	6.30	6.40	6.50
E1	4.30	4.40	4.50
e	0.65 BSC		
L	1.00 REF		
L1	0.50	0.60	0.75
θ	0°		8°

TOP VIEW

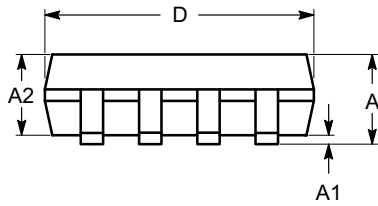

SIDE VIEW

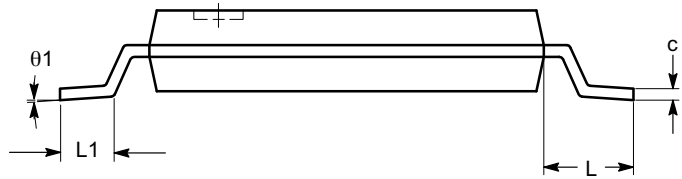

END VIEW

Notes:

- (1) All dimensions are in millimeters. Angles in degrees.
- (2) Complies with JEDEC MO-153.

P2010A

PACKAGE DIMENSIONS

SOIC 8, 150 mils
CASE 751BD-01
ISSUE O

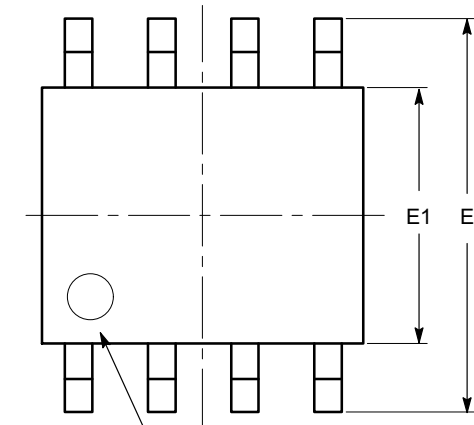

PIN # 1
IDENTIFICATION

TOP VIEW

SYMBOL	MIN	NOM	MAX
A	1.35		1.75
A1	0.10		0.25
b	0.33		0.51
c	0.19		0.25
D	4.80		5.00
E	5.80		6.20
E1	3.80		4.00
e	1.27 BSC		
h	0.25		0.50
L	0.40		1.27
θ	0°		8°

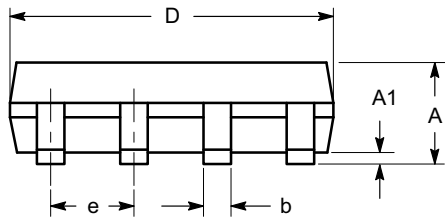

SIDE VIEW

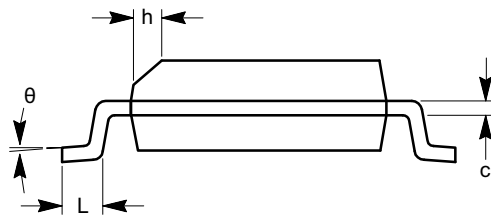

END VIEW

Notes:

- (1) All dimensions are in millimeters. Angles in degrees.
- (2) Complies with JEDEC MS-012.

P2010A

Table 6. ORDERING INFORMATION

Part Number	Marking	Package Type	Temperature
P2010AF-08ST	P2010AF	8-Pin SOIC, Tube, Pb Free	Commercial
P2010AF-08SR	P2010AF	8-Pin SOIC, Tape and Reel, Pb Free	Commercial
P2010AG-08ST	P2010AG	8-Pin SOIC, Tube, Green	Commercial
P2010AG-08SR	P2010AG	8-Pin SOIC, Tape and Reel, Green	Commercial
I2010AF-08ST	I2010AF	8-Pin SOIC, Tube, Pb Free	Industrial
I2010AF-08SR	I2010AF	8-Pin SOIC, Tape and Reel, Pb Free	Industrial
I2010AG-08ST	I2010AG	8-Pin SOIC, Tube, Green	Industrial
I2010AG-08SR	I2010AG	8-Pin SOIC, Tape and Reel, Green	Industrial
P2010AF-08TT	P2010AF	8-Pin TSSOP, Tube, Pb Free	Commercial
P2010AF-08TR	P2010AF	8-Pin TSSOP, Tape and Reel, Pb Free	Commercial
P2010AG-08TT	P2010AG	8-Pin TSSOP, Tube, Green	Commercial
P2010AG-08TR	P2010AG	8-Pin TSSOP, Tape and Reel, Green	Commercial
I2010AF-08TT	I2010AF	8-Pin TSSOP, Tube, Pb Free	Industrial
I2010AF-08TR	I2010AF	8-Pin TSSOP, Tape and Reel, Pb Free	Industrial
I2010AG-08TT	I2010AG	8-Pin TSSOP, Tube, Green	Industrial
I2010AG-08TR	I2010AG	8-Pin TSSOP, Tape and Reel, Green	Industrial

ON Semiconductor and  are registered trademarks of Semiconductor Components Industries, LLC (SCILLC). SCILLC reserves the right to make changes without further notice to any products herein. SCILLC makes no warranty, representation or guarantee regarding the suitability of its products for any particular purpose, nor does SCILLC assume any liability arising out of the application or use of any product or circuit, and specifically disclaims any and all liability, including without limitation special, consequential or incidental damages. "Typical" parameters which may be provided in SCILLC data sheets and/or specifications can and do vary in different applications and actual performance may vary over time. All operating parameters, including "Typicals" must be validated for each customer application by customer's technical experts. SCILLC does not convey any license under its patent rights nor the rights of others. SCILLC products are not designed, intended, or authorized for use as components in systems intended for surgical implant into the body, or other applications intended to support or sustain life, or for any other application in which the failure of the SCILLC product could create a situation where personal injury or death may occur. Should Buyer purchase or use SCILLC products for any such unintended or unauthorized application, Buyer shall indemnify and hold SCILLC and its officers, employees, subsidiaries, affiliates, and distributors harmless against all claims, costs, damages, and expenses, and reasonable attorney fees arising out of, directly or indirectly, any claim of personal injury or death associated with such unintended or unauthorized use, even if such claim alleges that SCILLC was negligent regarding the design or manufacture of the part. SCILLC is an Equal Opportunity/Affirmative Action Employer. This literature is subject to all applicable copyright laws and is not for resale in any manner.

PUBLICATION ORDERING INFORMATION

LITERATURE FULFILLMENT:
 Literature Distribution Center for ON Semiconductor
 P.O. Box 5163, Denver, Colorado 80217 USA
Phone: 303-675-2175 or 800-344-3860 Toll Free USA/Canada
Fax: 303-675-2176 or 800-344-3867 Toll Free USA/Canada
Email: orderlit@onsemi.com

N. American Technical Support: 800-282-9855 Toll Free
 USA/Canada
Europe, Middle East and Africa Technical Support:
 Phone: 421 33 790 2910
Japan Customer Focus Center
 Phone: 81-3-5773-3850

ON Semiconductor Website: www.onsemi.com
Order Literature: <http://www.onsemi.com/orderlit>
 For additional information, please contact your local Sales Representative