



P24C128E

I²C-Compatible Serial E²PROM

Data Sheet Rev.1.2

General Description

The P24C128E is 128-Kbit I²C-compatible Serial EEPROM (Electrically Erasable Programmable Memory) device. It contains a memory array of 16384x8bits, which is 64 bytes per page.

Features

- Single Supply Voltage and High Speed
 - ◇ Minimum operating voltage down to 1.7V
 - ◇ 1 MHz clock from 2.5V to 5.5V
 - ◇ 400kHz clock from 1.7V to 2.5V
- Low power CMOS technology
 - ◇ Read current 100uA, maximum
 - ◇ Write current 0.5mA, maximum
- Schmitt Trigger, Filtered Inputs for Noise Suppression
- Sequential & Random Read Features
- Page Write Modes, Partial Page Writes Allowed
- Software Write Protection(SWP) for Programmable Block
 - ◇ Upper quarter memory array
 - ◇ Upper half memory array
 - ◇ Upper 3/4 memory array
 - ◇ Whole memory array
- Software Programmable Device ID Configuration
 - ◇ 3 BIT DSC Register and configured by DSCWR command
 - ◇ Locked forever if Lock ID Page command executed
- Additional Write Lockable Page and 128-bit Serial Number
- Self-timed Write Cycle (5ms maximum)
- High Reliability
 - ◇ Endurance: 1 Million Write Cycles
 - ◇ Data Retention: 200 Years
 - ◇ ESD Protection(HBM): 4000V
 - ◇ Latch up Capability: +/- 200mA (25°C)
- Package:
 - ◇ 4-balls WLCSP. Ball Pitch 400umx400um
 - ◇ 4-balls WLCSP. Ball Pitch 400umx500um

1. Pin Configuration

1.1 Pin Configuration

Figure 1-1 WLCSP-4Balls (Ball pitch 400um*400um)

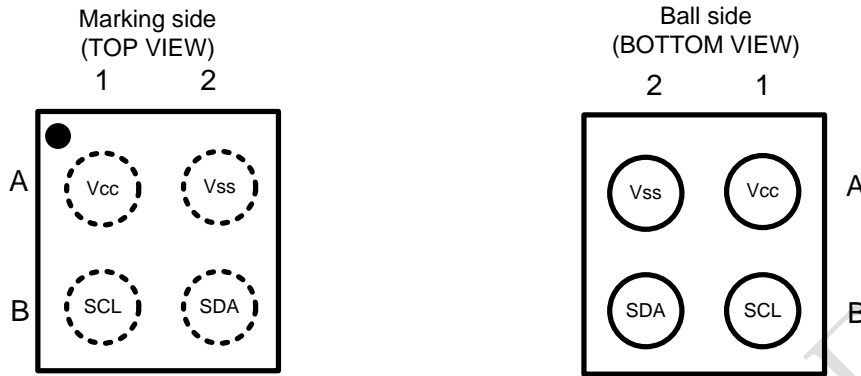
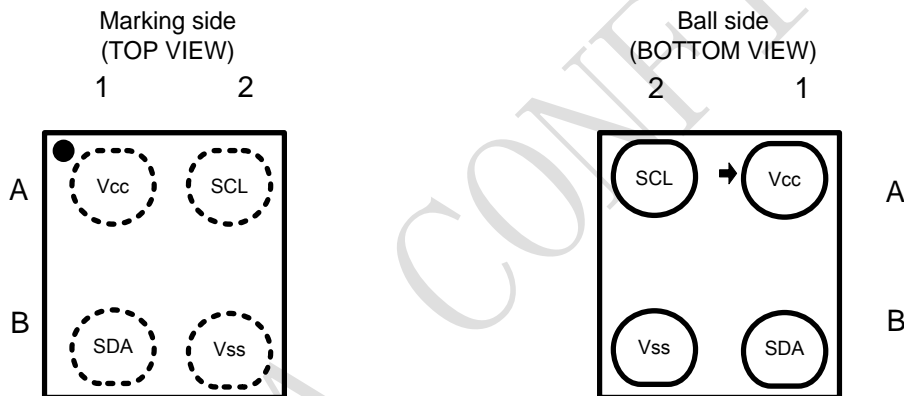

Figure 1-2 WLCSP-4Balls (Ball pitch 400um*500um)



1.2 Pin Definition

Table 1-1 Pin Definition for Package WLCSP4-balls (Ball pitch 400um)

Pin	Name	Type	Description
A1	V _{cc}	Power	Power Supply
A2	V _{ss}	Ground	Ground
B1	SCL	Input	Serial Clock Input
B2	SDA	I/O	Serial Data Input and Serial Data Output

Table 1-2 Pin Definition for Package WLCSP4-balls (Ball pitch 400um*500um)

Pin	Name	Type	Description
A1	V _{cc}	Power	Power Supply
A2	SCL	Input	Serial Clock Input
B1	SDA	I/O	Serial Data Input and Serial Data Output
B2	V _{ss}	Ground	Ground

1.3 Pin Descriptions

Serial Clock (SCL): The SCL input is used to clock in data at positive edges and clock out data of the device at negative edges.

Serial Data (SDA): The SDA pin is bidirectional for serial data transfer. This pin is open drain driven and may be wired-OR with any number of other open-drain or open-collector devices.

2. Block Diagram

Figure 2-1 Block Diagram

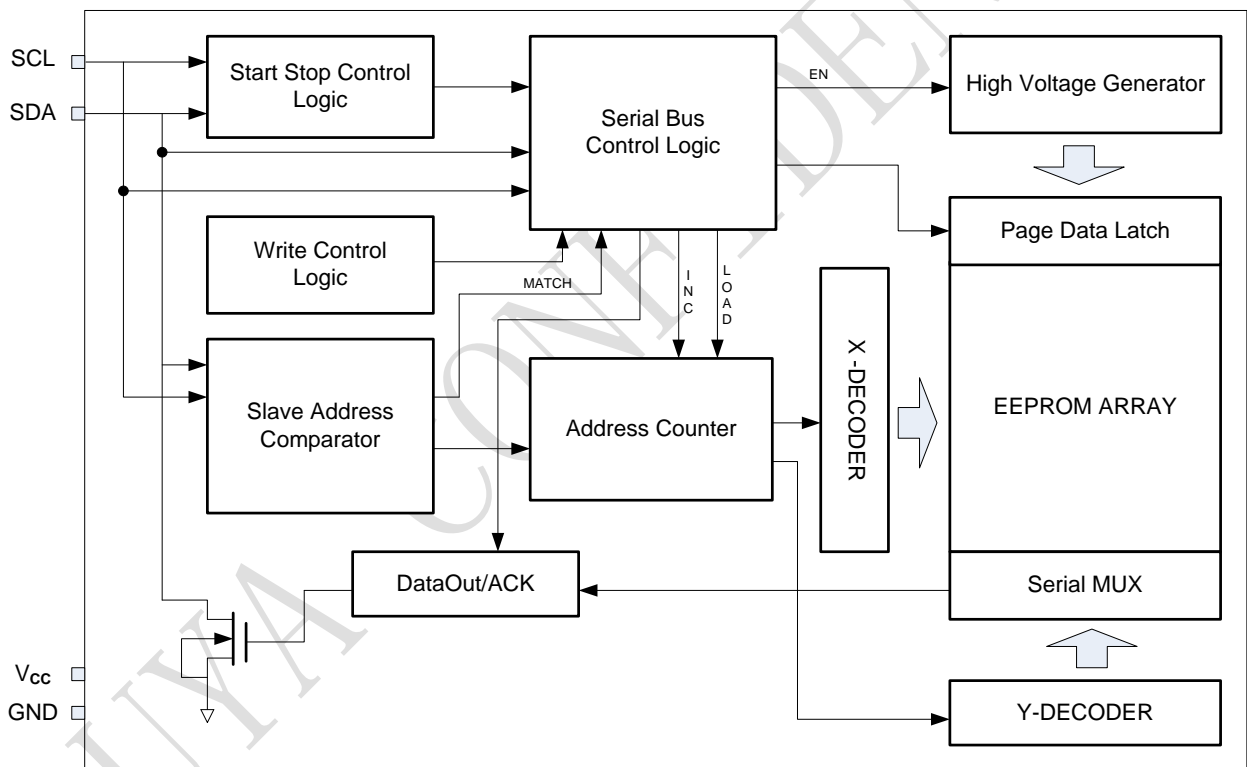

3. Electrical Characteristics

Absolute Maximum Ratings

- Storage Temperature -65°C to +150°C
- Operation Temperature -40°C to +125°C
- Maximum Operation Voltage..... 6.25V
- Voltage on Any Pin with
Respect to Ground. -1.0V to (V_{CC}+1.0) V
- DC Output Current 5.0 mA

NOTICE: Stresses above those listed under “Absolute Maximum Ratings” may cause permanent damage to the device. This is a stress rating only and functional operation of the device at those or any other conditions above those indicated in the operational listings of this specification is not implied. Exposure to maximum rating conditions for extended periods may affect device reliability.

Table 3-1 Pin Capacitance ^[1]

Symbol	Parameter	Max.	Units	Test Condition
C _{I/O}	Input / Output Capacitance (SDA)	8	pF	V _{I/O} =V _{SS}
C _{IN}	Input Capacitance (SCL)	6	pF	V _{IN} =V _{SS}

Note: [1] Test Conditions: T_A = 25°C, Freq. = 1MHz, V_{CC} = 5.0V.

Table 3-2 DC Characteristics (Unless otherwise specified, V_{CC} = 1.7V to 5.5V, T_A = -40°C to 85°C)

Symbol	Parameter	Min.	Typ.	Max.	Unit	Test Condition
V _{CC}	Supply Voltage	1.7	-	5.5	V	P24C128E
I _{sb}	Standby Current	-	-	0.6	μA	V _{CC} = 3.3V, T _A = 85°C
		-	-	1.0	μA	V _{CC} = 5.5V, T _A = 85°C
		-	-	2.0	uA	V _{CC} = 5.5V, T _A = 105°C
I _{CC1}	Supply Current	-	0.1	0.2	mA	V _{CC} = 5.5V, Read at 400Khz
I _{CC2}	Supply Current	-	0.5	1	mA	V _{CC} =5.5V Write at 400Khz
I _{LI}	Input Leakage Current	-	0.10	1.0	μA	V _{IN} = V _{CC} or V _{SS}
I _{LO}	Output Leakage Current	-	0.05	1.0	μA	V _{OUT} = V _{CC} or V _{SS}
V _{IL}	Input Low Level	-0.6	-	0.3V _{CC}	V	
V _{IH}	Input High Level	0.7V _{CC}	-	V _{CC} +0.5	V	
V _{OL1}	Output Low Level V _{CC} = 1.7V (SDA)	-	-	0.2	V	I _{OL} = 1.5 mA
V _{OL2}	Output Low Level V _{CC} = 3.0V (SDA)	-	-	0.4	V	I _{OL} = 2.1 mA
R _{pd}	Pull-down resistance on WCB	5	100		MΩ	V _{IN} = V _{CC}
		10	30		KΩ	V _{IN} < V _{IL}

Table 3-3 AC Characteristics (Unless otherwise specified, $V_{CC} = 1.7V$ to $5.5V$, $T_A = -40^{\circ}C$ to $85^{\circ}C$, $C_L=100pF$, Test Conditions are listed in Notes [2])

Symbol	Parameter	$1.7 \leq V_{CC} < 2.5$			$2.5 \leq V_{CC} \leq 5.5$			Units
		Min.	Typ.	Max.	Min.	Typ.	Max.	
f _{SCL}	Clock Frequency, SCL	-	-	400	-	-	1000	kHz
t _{LOW}	Clock Pulse Width Low	1.3	-	-	0.4	-	-	μs
t _{HIGH}	Clock Pulse Width High	0.6	-	-	0.4	-	-	μs
t _{AA}	Clock Low to Data Out Valid	0.05	-	0.9	0.05	-	0.55	μs
t _i	Noise Suppression Time	-	-	0.1	-	-	0.05	μs
t _{BUF}	Time the bus must be free before a new transmission can start	1.3	-	-	0.5	-	-	μs
t _{HD.STA}	START Hold Time	0.6	-	-	0.25	-	-	μs
t _{SU.STA}	START Setup Time	0.6	-	-	0.25	-	-	μs
t _{HD.DAT}	Data In Hold Time	0	-	-	0	-	-	μs
t _{SU.DAT}	Data In Setup Time	0.1	-	-	0.1	-	-	μs
t _R	Inputs Rise Time ^[1]	-	-	0.3	-	-	0.3	μs
t _F	Inputs Fall Time ^[1]	-	-	0.3	-	-	0.1	μs
t _{SU.STO}	STOP Setup Time	0.6	-	-	0.25	-	-	μs
t _{DH}	Data Out Hold Time	0.05	-	-	0.05	-	-	μs
t _{SU.WCB}	WCB pin Setup Time	1.2	-	-	0.6	-	-	μs
t _{HD.WCB}	WCB pin Hold Time	1.2	-	-	0.6	-	-	μs
t _{WR}	Write Cycle Time	-	-	5	-	-	5	ms

Notes: [1] This parameter is ensured by characterization not 100% tested

[2] AC measurement conditions:

- ✧ R_L (connects to V_{CC}): 1.3kΩ (2.5V, 5.5V), 10kΩ (1.7V)
- ✧ Input pulse voltages: 0.3 V_{CC} to 0.7 V_{CC}
- ✧ Input rise and fall times: $\leq 50ns$
- ✧ Input and output timing reference voltages: 0.5 V_{CC}

Table 3-4 Reliability Characteristic ^[1]

Symbol	Parameter	Min.	Typ.	Max.	Unit
EDR ^[2]	Endurance	1,000,000			Write cycles
DRET	Data retention	200			Years

Note: [1] This parameter is ensured by characterization and is not 100% tested

[2] Under the condition: 25°C, 3.3V, Page mode

Figure 3-1 Bus Timing

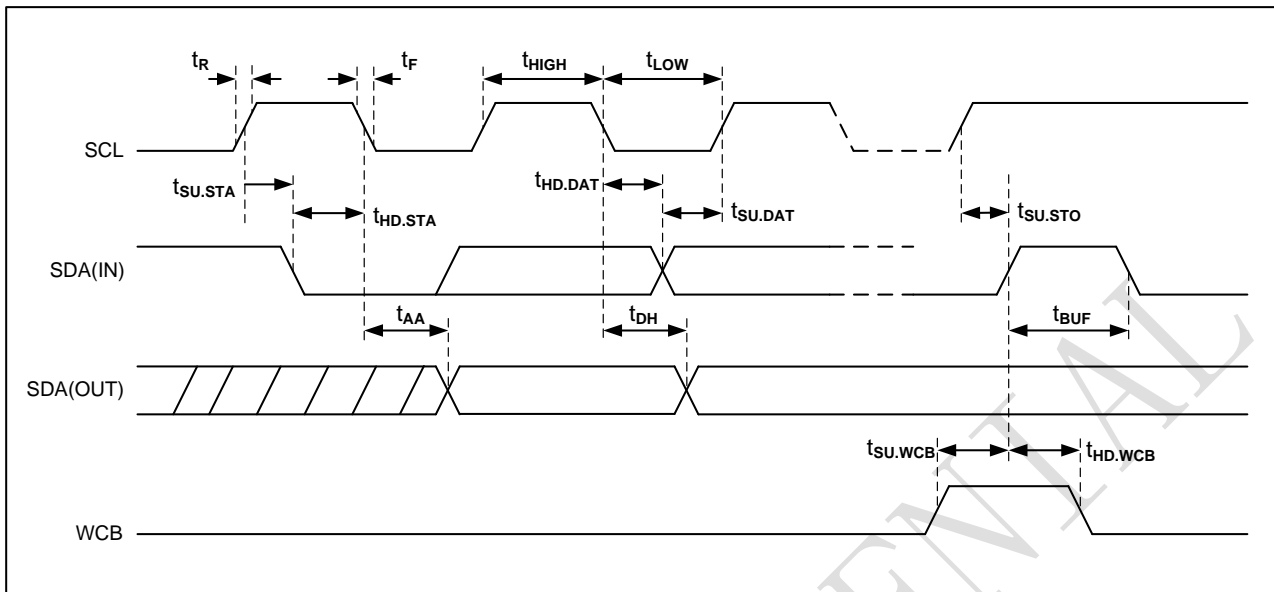
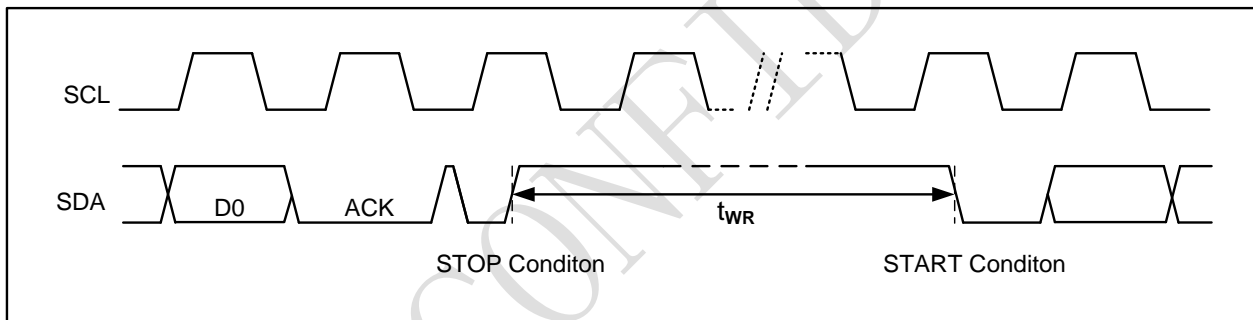

Figure 3-2 Write Cycle Timing



Note: [1] The write cycle time t_{WR} is the time from a valid STOP condition of a write sequence to the end of the internal clear/write cycle.

4. Device Operation

4.1 Data Input

The SDA pin is normally pulled high with an external device. Data on the SDA pin may change only during SCL low periods (Refer to Figure 4-1). Data changes during SCL high periods will indicate a START or STOP bit as defined below.

Figure 4-1 Data Validity

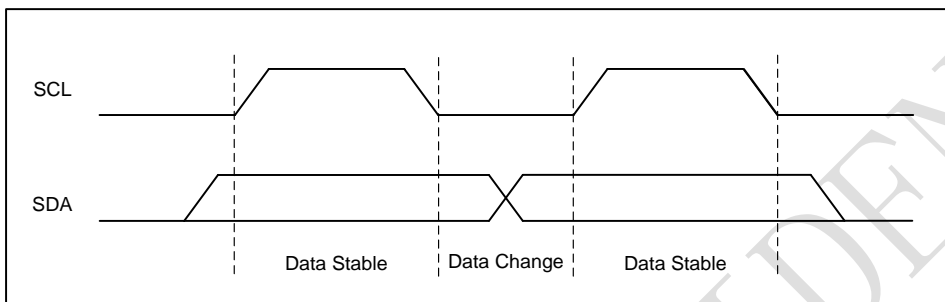

4.2 START Condition

A high-to-low transition of SDA with SCL high is a START condition which must precede any other command bits (Refer Figure 4-2).

4.3 Stop Condition

A low-to-high transition of SDA with SCL high is a STOP condition. After a read sequence, the STOP bit will place the P24C128E in a standby mode (Refer to Figure 4-2).

Figure 4-2 START and Stop Definition

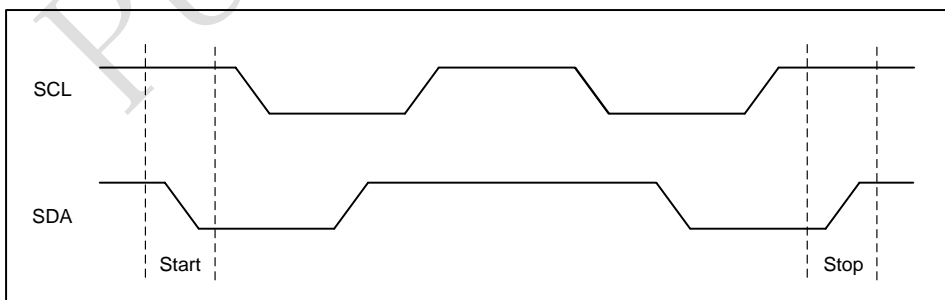

4.4 Acknowledge (ACK)

All addresses and data are serially transmitted to and from the P24C128E in 8-bit data. The P24C128E sends a “0” to acknowledge that it has received each data byte. This happens during the ninth clock cycle.

Figure 4-3 Acknowledge Bit Definition

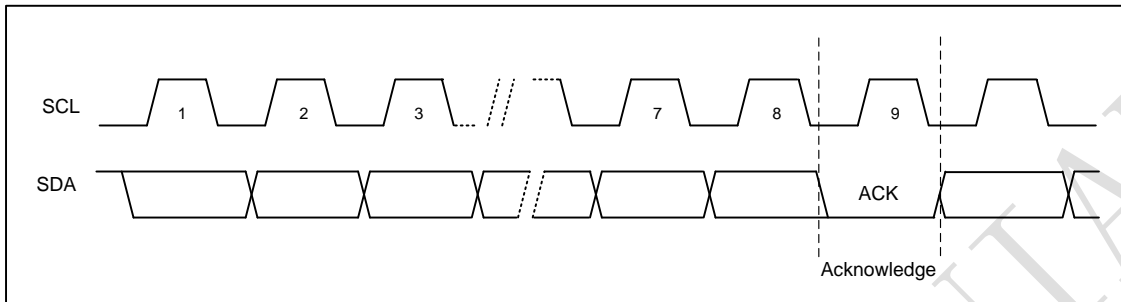

4.5 Standby Mode

The P24C128E features a low-power standby mode which is enabled:

- (a) After a fresh power up
- (b) After receiving a STOP bit in read mode
- (c) After completing a self-time internal programming operation

4.6 Soft Reset

After an interruption in protocol, power loss or system reset, any two-wire part can be reset by following these steps: (a) Create a START condition, (b) Clock in nine data bits “1” and (c) create another START bit followed by STOP bit condition, as shown below. The device is ready for the next communication after the above steps have been completed.

Figure 4-4 Soft Reset

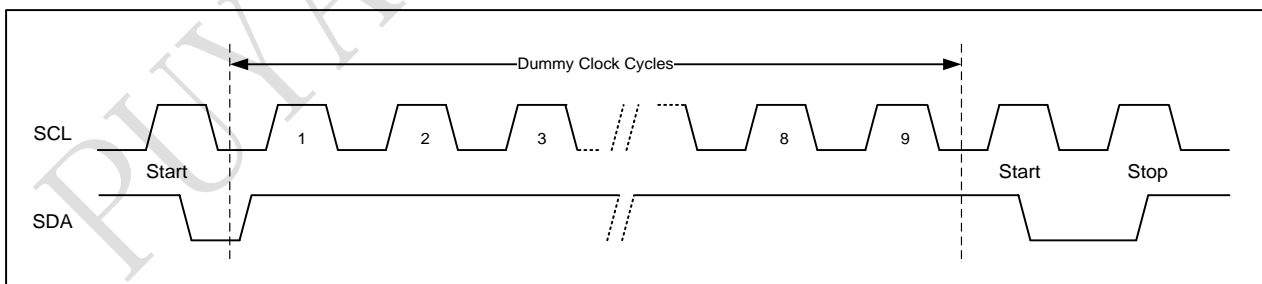

4.7 Device Addressing

The P24C128E requires an 8-bit device address following a START condition to enable the chip for a read or write operation (Refer to table below). The device address consists of a mandatory one-zero sequence for the first four most-significant bits, as shown.

Table 4-1 Device Address

Chip	Access area	Bit 7	Bit 6	Bit 5	Bit 4	Bit 3	Bit 2	Bit 1	Bit 0
P24C128E	Normal Area	1	0	1	0	DSC2	DSC1	DSC0	R/W
	ID Page	1	0	1	1	DSC2	DSC1	DSC0	R/W
	Lock Bit	1	0	1	1	DSC2	DSC1	DSC0	R/W
	DSC	1	0	1	1	DSC2	DSC1	DSC0	R/W
	Serial Number	1	0	1	1	DSC2	DSC1	DSC0	1
	SWP	1	0	1	0	DSC2	DSC1	DSC0	R/W

Note:

1. The Device Select Code DSC2/DSC1/DSC0 can software programmable by DSC register write.

Table 4-2 Word Address0

Chip	Data	Bit 7	Bit 6	Bit 5	Bit 4	Bit 3	Bit 2	Bit 1	Bit 0
P24C128E	Normal Area	0	X	A13	A12	A11	A10	A9	A8
	ID Page	X	X	X	X	0	0	X	X
	Lock Bit	X	X	X	X	0	1	X	X
	DSC	X	X	X	X	1	1	X	X
	Serial Number	X	X	X	X	1	0	X	X
	SWP	1	X	X	X	X	X	X	X

Table 4-3 Word Address1

Chip	Data	Bit 7	Bit 6	Bit 5	Bit 4	Bit 3	Bit 2	Bit 1	Bit 0
P24C128E	Normal Area	A7	A6	A5	A4	A3	A2	A1	A0
	ID Page	X	X	A5	A4	A3	A2	A1	A0
	Lock Bit	X	X	X	X	X	X	X	X
	DSC	X	X	X	X	X	X	X	X
	Serial Number	X	X	X	X	A3	A2	A1	A0
	SWP	X	X	X	X	X	X	X	X

The bit0 of the device address is the read/write operation select bit. A read operation is initiated if this bit is high and a write operation is initiated if this bit is low. Upon a matched comparison of the device address, the Chip will output a zero. If not, the device will return to a standby state.

4.8 Data Security

P24C128E has a software write protection scheme that allows the user to write protect the memory. Please refer 5.1.6 for detail.

5. Instructions

5.1 Write Operations

5.1.1 Byte Write

A write operation requires one 8-bit device address following the two-byte word address and acknowledgment. Upon receipt of this device address, the P24C128E will again respond with a “0” and then clock in the first 8-bit data. Following receipt of the 8-bit data word, the P24C128E will output a “0” and the master, such as a master, must terminate the write sequence with a STOP bit. And then the P24C128E enters an internally timed write cycle. All inputs are disabled during this write cycle and the P24C128E will not respond until the write is complete (Refer to Figure 5-1).

Figure 5-1 Byte Write

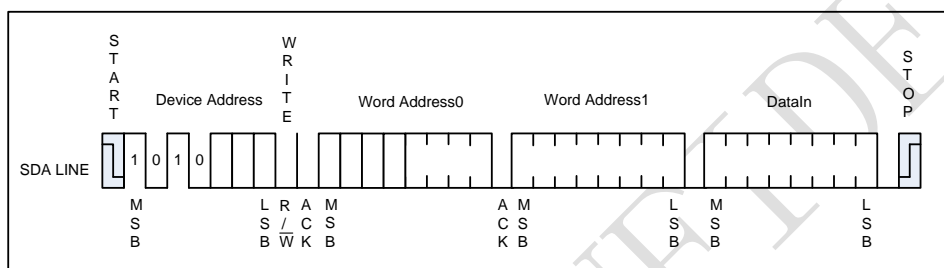

5.1.2 Page Write

A page write is initiated in the same way as a byte write. But the master does not send a STOP bit after the first data word is clocked in. Instead, after the P24C128E acknowledges receipt of the first data, the master can transmit more data continuously. The P24C128E will respond with a “0” after each data byte received. The master must terminate the page write sequence with a STOP bit.

Figure 5-2 Page Write

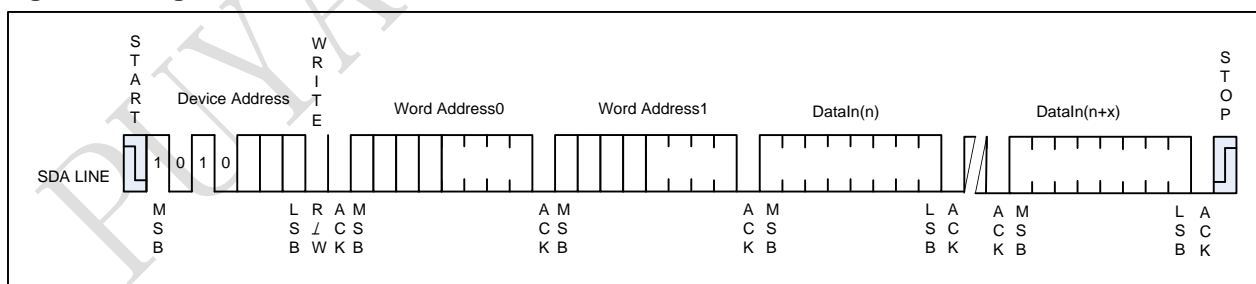

The lowest six address bits of the word address, the page address for P24C128E, are internally incremented following the receipt of each data word. The higher data word address bits are not incremented, retaining the memory page row location. When the page boundary is reached, the word address rolls over to the beginning of the same page. And previous data will be overwritten.

5.1.3 Acknowledge Polling

Once the internally timed write cycle has started, the P24C128E inputs are disabled and acknowledge polling can be initiated. This involves sending a START condition followed by the device address. The read/write bit is representative of the operation desired. Until the internal write cycle has completed will the device respond with a “0”, allowing the read or write sequence to continue.

5.1.4 Write Identification Page

The Identification Page (64bytes for P24C128E respectively) is an additional page which can be written and (later) permanently locked in Read-only mode. It is written by the Write Identification Page instruction. This instruction uses the same protocol and format as Page Write (into memory array), except for the following differences:

- Device type identifier = 1011b
- Word Address bits A11/A10 which must be ‘00’.
- Address bits A5~A0 define the byte address inside the Identification page for P24C128E respectively.

If the Identification page is locked, the data bytes transferred during the Write Identification Page instruction are not acknowledged (No-ACK).

5.1.5 Lock Identification Page

The Lock Identification Page instruction (Lock ID) permanently locks the Identification page and DSC registers in Read-only mode. The Lock ID instruction is similar to Byte Write (into memory array) with the following specific conditions:

- Device type identifier = 1011b
- Address bit A11A10 must be ‘01’; all the other address bits are don’t care
- The data byte must be equal to the binary value xxxx_xx1x, where x is don’t care

5.1.6 Soft Write Protection

By writing specific values in a register (*Table 5-1*) located at address 1xxx_xxxx_xxxx_xxxxB, the memory array can be write-protected by blocks, which size can be defined as:

- the upper quarter memory array
- the upper half memory array
- the upper 3/4 memory array
- the whole memory array

Writing in the Write protect register is performed with a Byte Write instruction at address 1xxx_xxxx_xxxx_xxxxB. Bits 7~5 of the data byte are not significant (Don't Care). Writing more than one byte will discard the write cycle (Write protect register content will not be changed)

Table5-1 SWP Register

Bit	7	6	5	4	3	2	1	0	Default
Bit Definition	-	-	-	-	Write protect activation	Size of write protected block		Write protect lock	/
R/W	RO	RO	RO	RO	RW	RW	RW	RW	/
Default	0	0	0	0	0	0	0	0	00H

Table5-11 Bit Definition for SWP Register

Bit	Definition	Description	Defaults	Note
7~4	/	Reserved for future use	0000	
3	Write protect activation	Enables or disables the Write protection 0: the whole memory can be written (no Write protection) 1: the concerned block is write-protected	0	
2~1	Size of write protected block	Define the size of the memory block to be protected against write instructions 00: the upper quarter of memory is write-protected 01: the upper half memory is write-protected 10: the upper 3/4 of memory are write-protected 11: the whole memory is write-protected	00	
0	Write protect lock	Locks the write protect status 0: bits 3~0 can be modified 1: bits 3~0 cannot be modified and therefore the memory write protection is frozen.	0	

Table5-12 Protected Area Address Range

SWPBLOCK	Description	Protected Area Address(Hex)
		P24C128E
00B (default)	The upper quarter of memory is write-protected	3000~3FFF
01B	The upper half memory is write-protected	2000~3FFF
10B	The upper 3/4 of memory are write-protected	1000~3FFF
11B	The whole memory is write-protected	0000~3FFF

5.1.7 DSC Register Write Command (DSCWR)

The Device Select Code is software programmable by the DSC Register Write Command with an instruction similar to Byte Write (into memory array) with the following specific conditions:

- Device type identifier = 1011b
- Address bit A11A10 must be '11', all other address bits are don't care.

If a lock ID page command is send, both the ID page and DSC Register is locked. The DSC[2:0] register is then frozen.

Table5-13 DSC Register

Bit	7	6	5	4	3	2	1	0	Default
Bit Definition	-	-	-	-	-	DSC[2:0]			/
R/W	RO	RO	RO	RO	RO	RW	RW	RW	/

Default	0	0	0	0	0	0	0	0	00H
---------	---	---	---	---	---	---	---	---	-----

Bit	Nonvolatile bit	Description	Default settings	Note
7~3	/	Reserved for future use	00000	
2~0	DSC[2:0]	The Device ID of the EEPROM is constructed as {1011/1010, DSC[2:0], R/W}. DSC[2:0] is defined as Device Select Code.	000	

5.2 Read Operations

Read operations are initiated the same way as write operations with the exception that the read/write select bit in the device address word is set to “1”. There are three read operations: Current Address Read; Random Address Read and Sequential Read.

5.2.1 Current Address Read

The last address accessed during the last read or write operation is always incremented by one after the STOP bit of the last command. Then the Current Address Read instruction read data start from that address and increased by one after every data byte read. The address counter rolls over to the first byte of the first page if the last byte of the last memory page is encountered.

Once the device address with the read/write select bit set to “1” is clocked in and acknowledged by the device, the data at the current address is serially clocked out. The master does not respond with an input “0” but generate a STOP bit (Refer to Figure 5-3).

Figure 5-3 Current Address Read

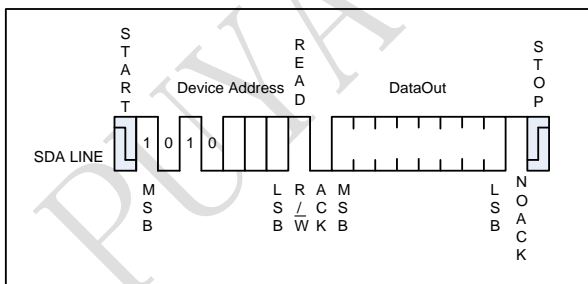

5.2.2 Random Read

A Random Read requires a “dummy” byte write sequence to load in the word address. Once the device address and word address are clocked in and acknowledged by the device, the master must generate another START condition. The master now initiates a Current Address Read by sending a device address with the read/write select bit high. The device acknowledges the device address and serially clocks out the data word. The master does not respond with a “0” but generate a STOP bit (Refer to Figure 5-4).

Figure 5-4 Random Read

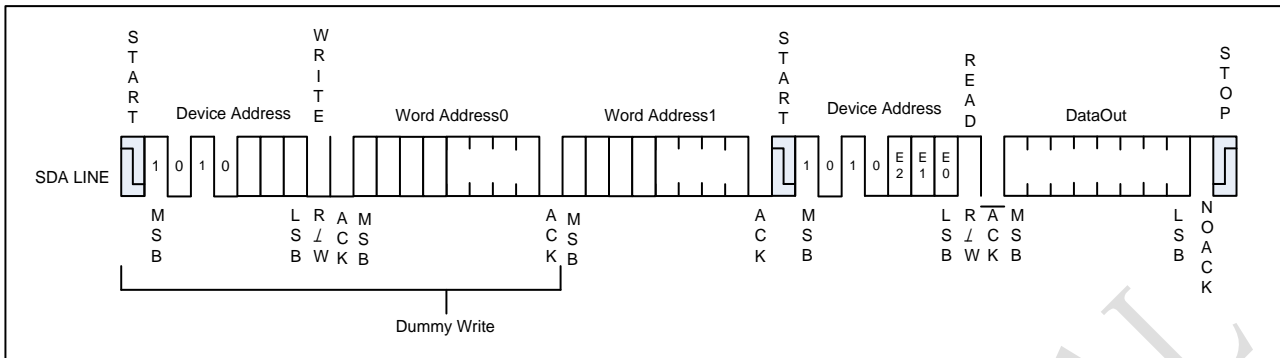

5.2.3 Sequential Read

Sequential Reads are initiated by either a Current Address Read or a Random Address Read. After the master receives a data byte, it responds with acknowledge. As long as the device receives acknowledge, it will continue to increment the word address and serially clock out sequential data bytes. When the memory address limit (Max. address) is reached, the word address will roll-over and the Sequential Read will continue. The Sequential Read operation is terminated when the master does not respond with a “0” but generate a STOP bit (Refer to Figure 5-5)

Figure 5-5 Sequential Read

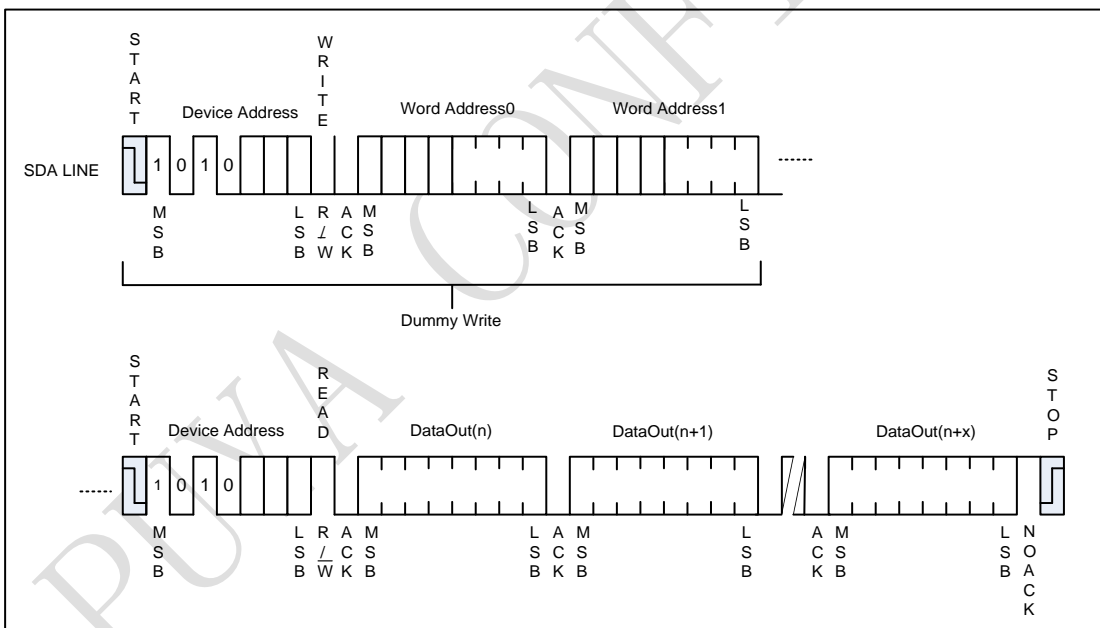

5.2.4 Read Identification Page

The Identification Page can be read by Read Identification Page instruction which uses the same protocol and format as the Read Command (from memory array) with device type identifier defined as 1011b. The

MSB address bits A11~A10 must be 0, and the LSB address bits A5~A0 define the byte address inside the Identification Page. The number of bytes to read in the ID page must not exceed the page boundary (e.g. when reading the Identification Page from location 10d, the number of bytes should be less than or equal to 54, as the ID page boundary is 64 bytes).

5.2.5 Read the Lock Status

The locked/unlocked status of the Identification page can be checked by transmitting a specific truncated command [Identification Page Write instruction + one data byte] to the device. The device returns an acknowledge bit if the Identification page is unlocked, otherwise a NoACK bit if the Identification page is locked.

Figure 5-5 Lock Status Read (When Identification page locked, return NoACK after one data byte)

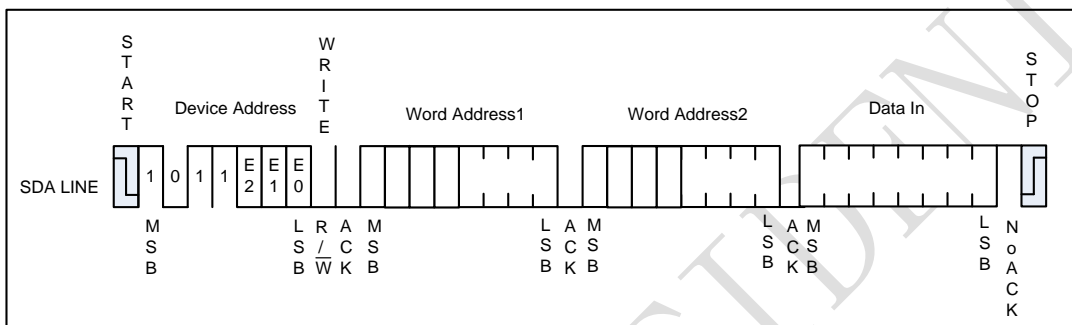

5.2.6 Read Serial Number

The Serial Number is only 16-bytes and is Read-only.

Reading the Serial Number is similar to the sequential read sequence but requires use of the device address. Refer to Table 4-1, the device type identifier should be 1011B. The word address A11~A10 must be 10B, A3~A0 must defines the byte address inside the Serial Number. It is recommend A3~A0 be 0 and the read data number must be 16 to guarantee the entire 128-bit value correctly read out.

Example: If the application desires to read the first byte of the serial number, the word address input would need to be 0800h.

When the end of the 128-bit serial number is reached (16 bytes of data), continued reading of the extended memory region will result in an additional 16 bytes of 00h data. Upon reaching the end of the 16-byte extended memory region, the data word address will roll-over back to the beginning of the 128-bit serial number. The Serial Number Read operation is terminated when the master does not respond with a zero (ACK) and instead issues a STOP bit (Refer to Figure 5-6)

Figure 5-6 Serial Number Read

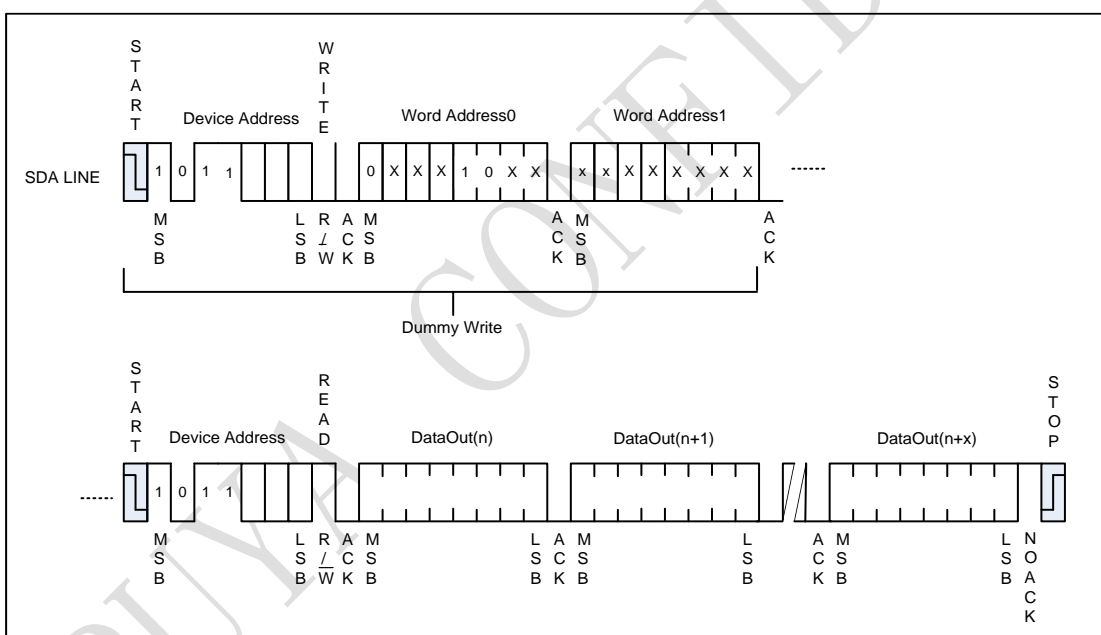

5.2.6 Read the Soft Write Protect register

Reading the Soft Write Protect register is performed with a Random Read instruction at address 1xxx_xxxx_xxxx_xxxxB. Bits b7~b4 of the Soft Write Protect register content are read as 4'B0000. The signification of the Protect Register lower bits b3~b0 are defined in Section 5.1.6. Reading more than one byte will loop on reading the Soft Write Protect Register value. The Soft Write Protect register cannot be read while a write cycle (tw) is ongoing.

5.2.7 Read the DSC register

Reading the DSC[2:0] register is performed with a Random Read instruction with device identifier “1011B” and Word Address bit A11/A10 11B. The 3 LSB of the output data is expected to be the same with the Device Select Code in Device address.

PUYA CONFIDENTIAL

6. Ordering Code Detail

Example:

P 2 4 C 128 E - C 4 H - M I R

Company Designator

P = Puya Semiconductor

Product Series Name

24C = I2C-compatible Interface EEPROM

Device Density

128 = 128K bit

Device Reversion

E = Version E

Package Option

C4: 4-balls WLCSP, Ball pitch 400umX400um

D4: 4-balls WLCSP, Ball pitch 400umX500um

Plating Technology

H: RoHS Compliant, Halogen-free, Antimony-free

Operation Voltage

M: 1.7~5.5V

Device Grade

I: -40~85C

K: -40~105C

Shipping Carrier Option

R :TAPE & REEL

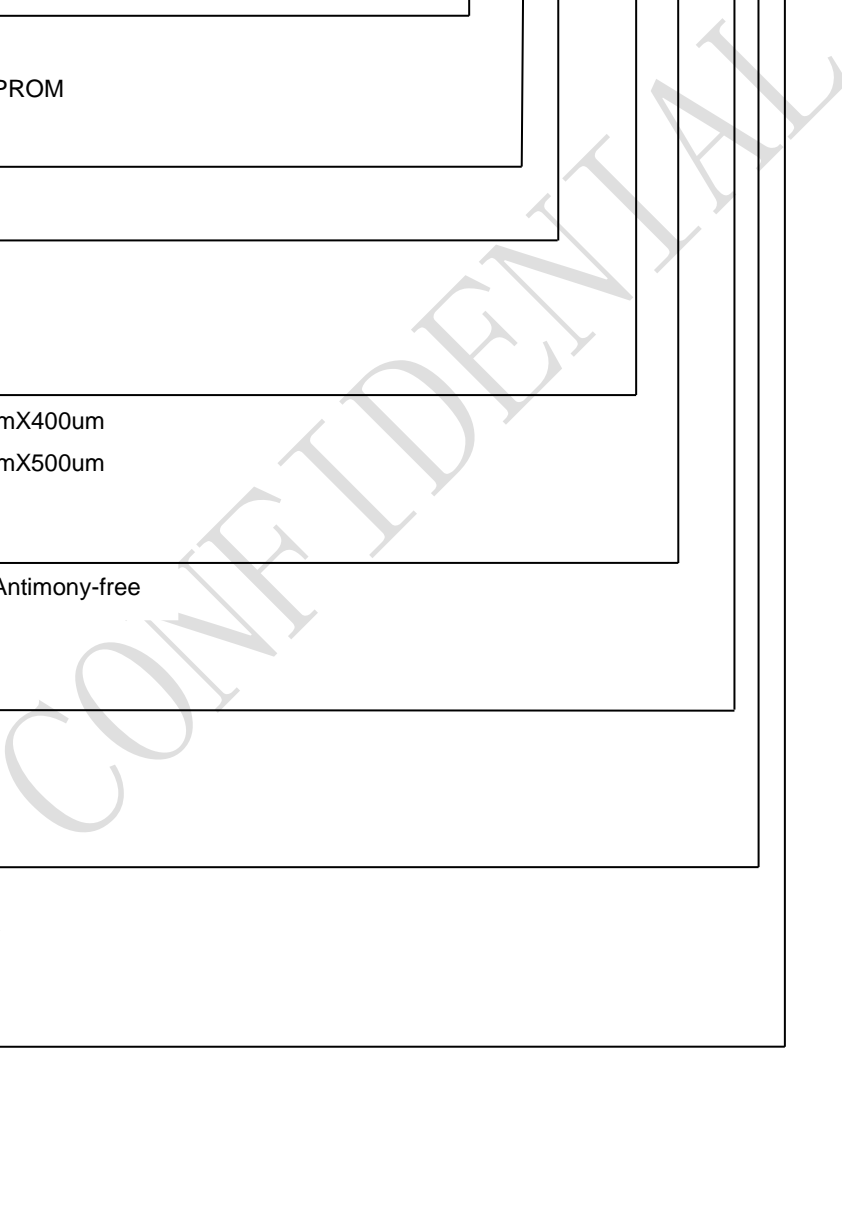

7. Package information

7.1 4-Balls WLCSP (Ball Pitch 400um*400um)

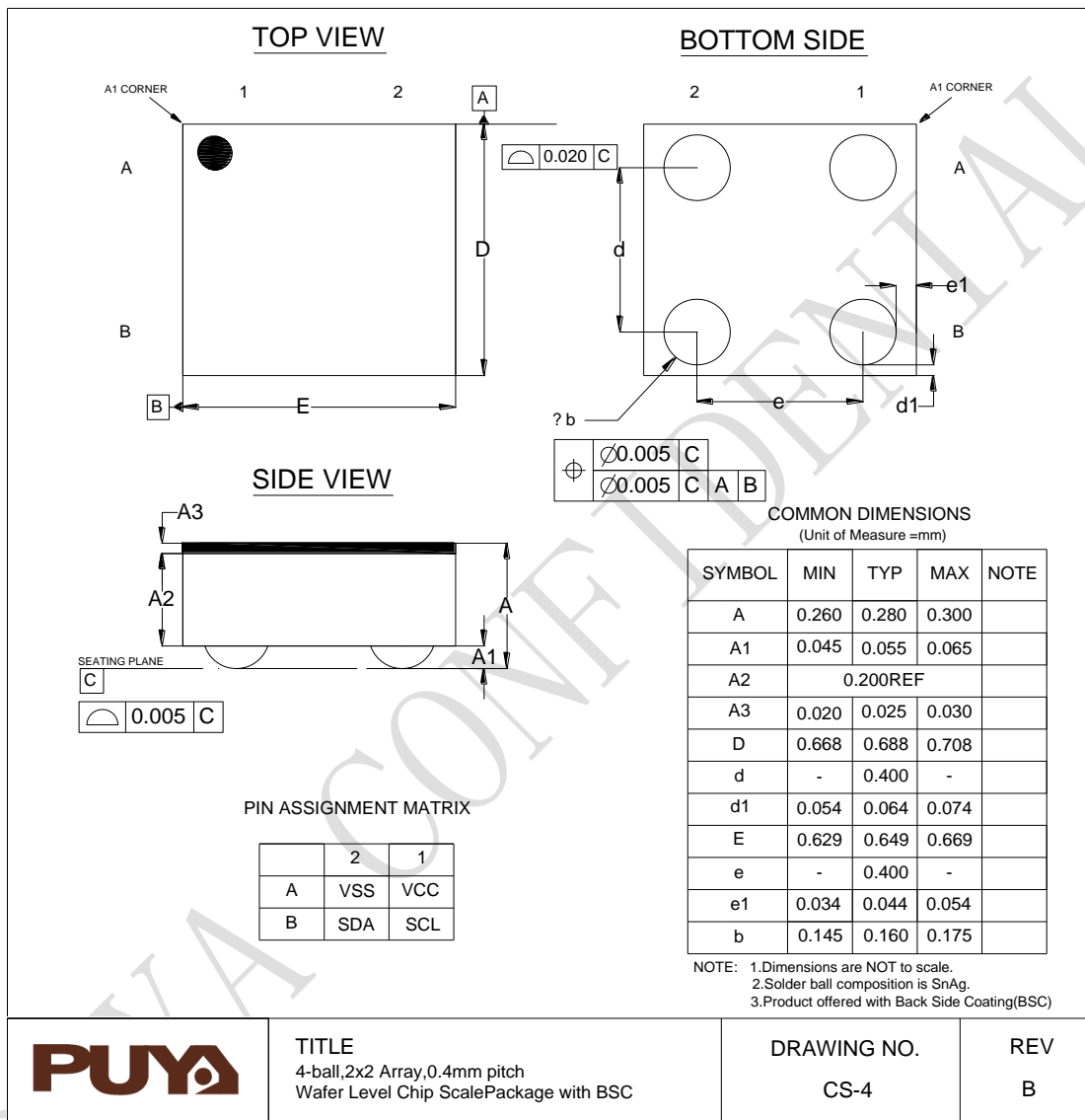

<Tape and Reel information>

Tape	Embossed carrier tape
Quantity	3000pcs
Direction of feed	E2 (The direction is the 1pin of product is at the upper left when you hold reel on the left hand and you pull out the tape on the right hand)

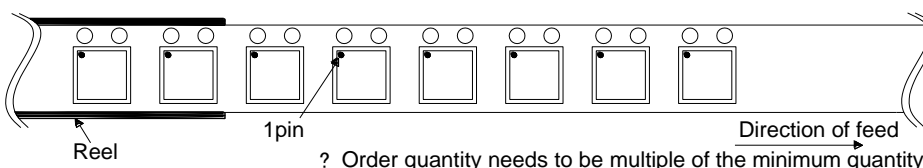

7.2 4-Balls WLCSP (Ball Pitch 400um*500um)

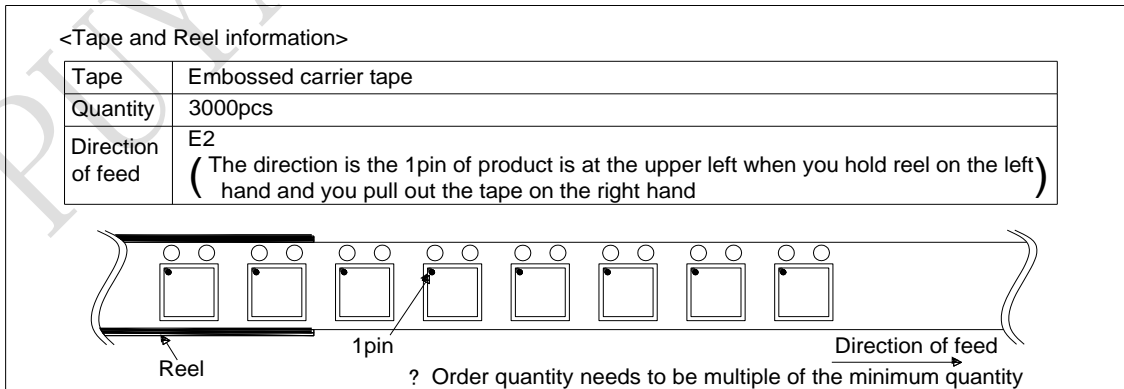
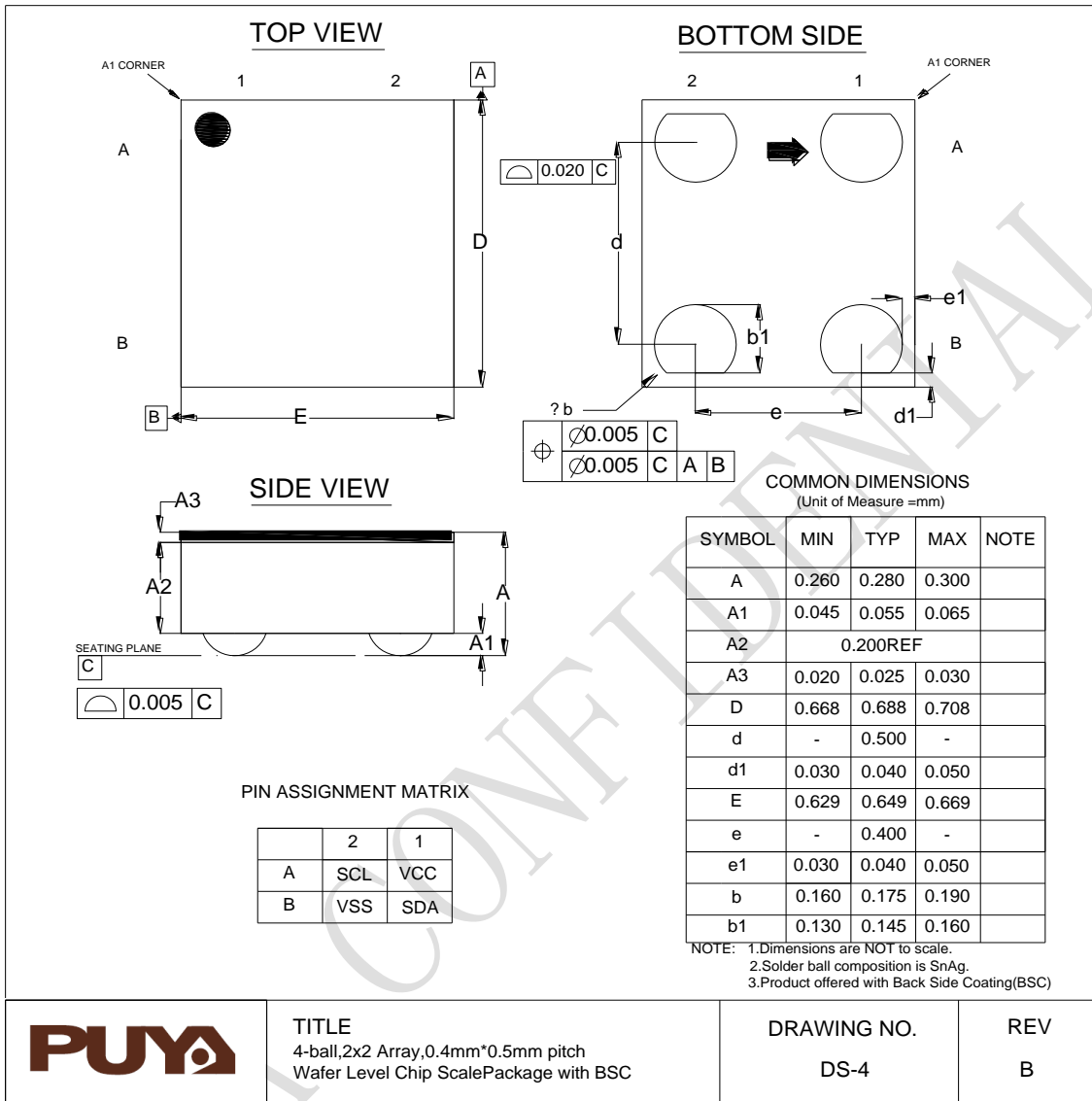



Puya Semiconductor Co., Ltd.

IMPORTANT NOTICE

Puya Semiconductor reserves the right to make changes without further notice to any products or specifications herein. Puya Semiconductor does not assume any responsibility for use of any its products for any particular purpose, nor does Puya Semiconductor assume any liability arising out of the application or use of any its products or circuits. Puya Semiconductor does not convey any license under its patent rights or other rights nor the rights of others.