

Low-Cost Notebook EMI Reduction IC

Features

- Provides up to 15 dB of EMI suppression
- FCC approved method of EMI attenuation
- Generates a 1X low EMI spread spectrum clock of the input frequency
- Operates between 20MHz and 38MHz input frequency range
- External loop filter for spread percentage adjustment
- Spreading ranges from $\pm 0.25\%$ to $\pm 2.5\%$
- Ultra low cycle-to-cycle jitter
- Zero-cycle slip at small deviations
- 3.3 V operating voltage range
- 10 mA output drives
- TTL or CMOS compatible outputs
- Low power CMOS design
- Available in 8-pin SOIC and TSSOP
- Available for industrial temperature operating range (-40°C to 85°C)

Block Diagram

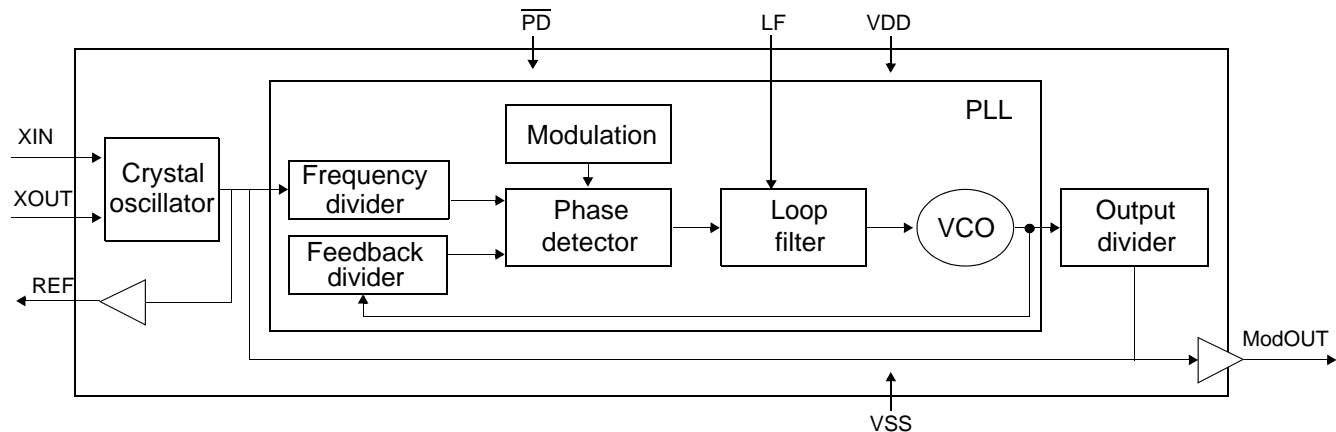

Product Description

The P2779A is a versatile spread spectrum frequency modulator designed specifically for mobile and digital camera and other digital video and imaging applications. The P2779A reduces electromagnetic interference (EMI) at the clock source, which provides system-wide reduction of EMI of all clock dependent signals. The P2779A allows significant system cost savings by reducing the number of circuit board layers and shielding that are traditionally required to pass EMI regulations.

The P2779A uses the most efficient and optimized modulation profile approved by the FCC.

The P2779A modulates the output of a single PLL in order to spread the bandwidth of a synthesized clock and, more importantly, decreases the peak amplitudes of its harmonics. This results in significantly lower system EMI compared to the typical narrow-band signal

produced by oscillators and most frequency generators. Lowering EMI by increasing a signal's bandwidth is called spread spectrum clock generation.

Applications

The P2779A is targeted toward mobile 3D graphics chip set applications

Pin Diagram

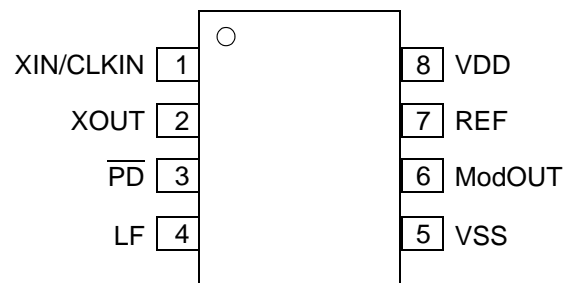



Pin Description

Pin #	Name	Type	Description
1	XIN/CLKIN	I	Connect to crystal or clock input.
2	XOUT	I	Crystal output.
3	PD	I	Power-down control pin. Pull low to enable power-down mode. This pin has an internal pull-up resistor. ¹
4	LF	I	External loop filter for the PLL. By changing the value of the CRC circuit, the percentage spread can be adjusted accordingly. (See Loop Filter Selection Table for detail value.)
5	VSS	P	Ground connection. Connect to system ground.
6	ModOUT	O	Spread Spectrum clock output.
7	REF	O	Provides a reference clock output of the input frequency.
8	VDD	P	Connect to +3.3 V.

1. Connect to VDD if not used.

Loop Filter Selection Table VDD 3.3 V

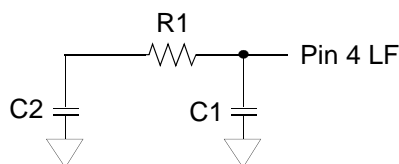

Input (MHz)	FS1	FS0	BW = ± 0.50%			BW = ± 0.75%			BW = ± 1.00%			BW = ± 1.25%		
			C1 (pF)	C2 (pF)	R1 (ohms)	C1 (pF)	C2 (pF)	R1 (ohms)	C1 (pF)	C2 (pF)	R1 (ohms)	C1 (pF)	C2 (pF)	R1 (ohms)
20	1	0	270	100,000	330	270	100,000	560	270	100,000	750	560	100,000	910
21 - 22	1	0	270	100,000	390	270	100,000	620	270	100,000	866(1%)	560	100,000	1,100
23 - 24	1	0	270	100,000	510	270	100,000	750	270	10,000	1,000	680	6,800	1,200
25 - 26	1	0	270	100,000	560	270	100,000	820	270	12,000	1,200	470	4,700	1,200
27 - 28	1	0	270	100,000	620	270	100,000	1,000	270	6,800	1,200	330	3,300	1,200
29 - 30	1	0	270	100,000	750	270	100,000	1,100	270	3,900	1,200	330	3,300	1,500
31 - 32	1	0	270	100,000	820	270	100,000	1,200	270	12,000	2,200	680	6,800	2,200
33 - 34	1	0	270	100,000	910	270	100,000	1,300	270	10,000	2,200	390	3,900	2,200
35 - 36	1	0	270	100,000	1,000	270	100,000	1,500	270	5,600	2,200	270	2,700	2,200
37 - 38	1	0	270	100,000	1,200	270	100,000	1,600	270	3,300	2,200	270	2,700	2,700

Please contact factory for loop filter values if desired spread settings are not listed.



Spread Spectrum Selection

The P2779A performs zero cycle slip when set at low percentage spreading. This prevents any occurrence of system timing error. The optimal setting should minimize system EMI to the fullest without affecting system performance. The spreading is described as a percentage deviation of the center frequency. (Note that the center frequency is the frequency of the external reference input on CLKIN, pin 1.)

The P2779A is designed for PC peripheral, networking, notebook PC, and LCD monitor applications. It is optimized for operation from 20 MHz to 38 MHz. The P2779A's spread percentage selection is determined by the external LF value specified in the Loop Filter Selection Table. The external LF allows the user to fine tune the spread percentage to optimize the EMI reduction benefits of the spread spectrum.

Application Schematic

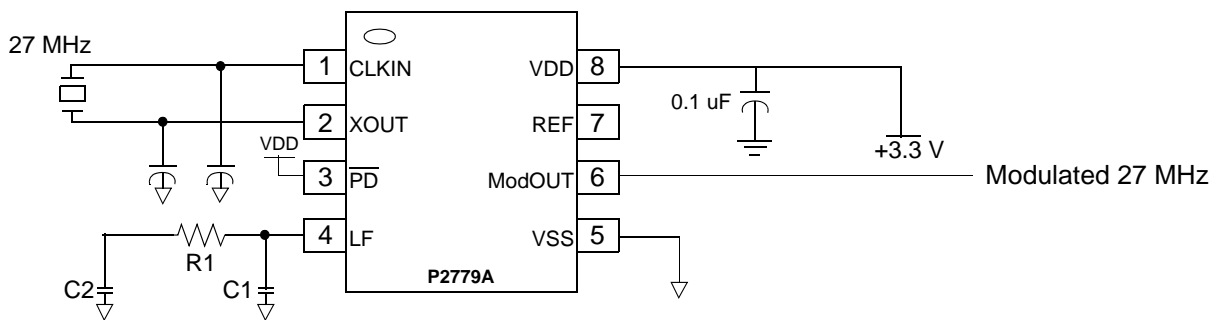

PD selection: Power dissipation can be reduced by completely turning off the IC.



Absolute Maximum Ratings

Symbol	Parameter	Rating	Units
V_{DD}, V_{IN}	Voltage on any pin with respect to GND	-0.5 to +7.0	V
T_{STG}	Storage temperature	-65 to +125	°C
T_A	Operating temperature	-40 to +85	°C

DC Electrical Characteristics

Symbol	Parameter	Min	Typ	Max	Units
V_{IL}	Input low voltage	GND - 0.3	–	0.8	V
V_{IH}	Input high voltage	2.0	–	$V_{DD} + 0.3$	V
I_{IL}	Input low current (internal input pull-up resistor)	–	60	–	μ A
I_{IH}	Input high current (internal input pull-up resistor on DIV2 and SR0)	–	0	–	μ A
I_{XOL}	XOUT output low current (at 0.4 V, $V_{DD} = 3.3$ V)	–	10	–	mA
I_{XOH}	XOUT output high current (at 2.5 V, $V_{DD} = 3.3$ V)	–	10	–	mA
V_{OL}	Output low voltage ($V_{DD} = 3.3$ V, $I_{OL} = 20$ mA)	–	–	0.4	V
V_{OH}	Output high voltage ($V_{DD} = 3.3$ V, $I_{OH} = 20$ mA)	2.5	–	–	V
I_{DD}	Static supply current	–	3	–	mA
I_{CC}	Dynamic supply current (3.3 V, 25 pF loading, 32 MHz)	–	12	–	mA
V_{DD}	Operating voltage	3.0	3.3	3.6	V
t_{ON}	Power-up time (first locked cycle after power up)	–	7	–	mS
Z_{OUT}	Clock output impedance	–	28	–	Ω

AC Electrical Characteristics

Symbol	Parameter	Min	Typ	Max	Units
f_{IN}	Input frequency	20	–	38	MHz
f_{OUT}	Output frequency	20	–	38	MHz
t_{LH}^1	Output rise time (measured at 0.8 V to 2.0 V)	–	1	–	ns
t_{HL}^1	Output fall time (measured at 2.0 V to 0.8 V)	–	1	–	ns
t_{JC}	Jitter (cycle to cycle)	–	± 175	–	ps
t_D	Output duty cycle	45	50	55	%

1. t_{LH} and t_{HL} are measured into a capacitive load of 15 pF.



Mechanical Package Outline (8-Pin SOIC)

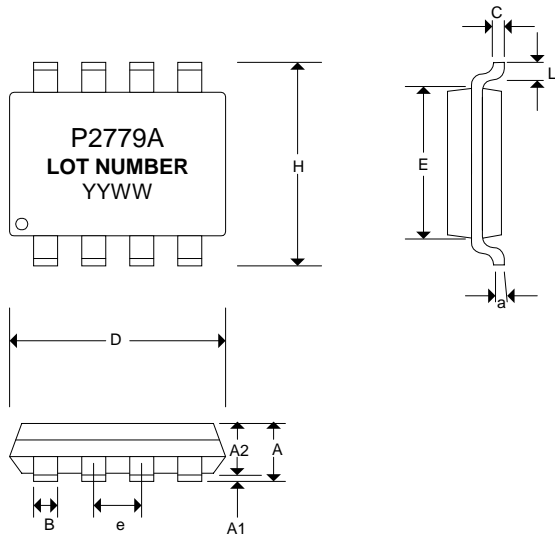

SYMBOL	INCHES			MILLIMETERS		
	MIN	NOR	MAX	MIN	NOR	MAX
A	0.057	0.064	0.071	1.45	1.63	1.80
A1	0.004	0.007	0.010	0.10	0.18	0.25
A2	0.053	0.061	0.069	1.35	1.55	1.75
B	0.012	0.016	0.020	0.31	0.41	0.51
C	0.004	0.006	0.01	0.10	0.15	0.25
D	0.186	0.194	0.202	4.72	4.92	5.12
E	0.148	0.156	0.164	3.75	3.95	4.15
e	0.050 BSC			1.27 BSC		
H	0.224	0.236	0.248	5.70	6.00	6.30
L	0.012	0.020	0.028	0.30	0.50	0.70
a	0°	5°	8°	0°	5°	8°

Note: Controlling dimensions are millimeters.

SOIC - 0.074 grams unit weight

Mechanical Package Outline (8-Pin TSSOP)

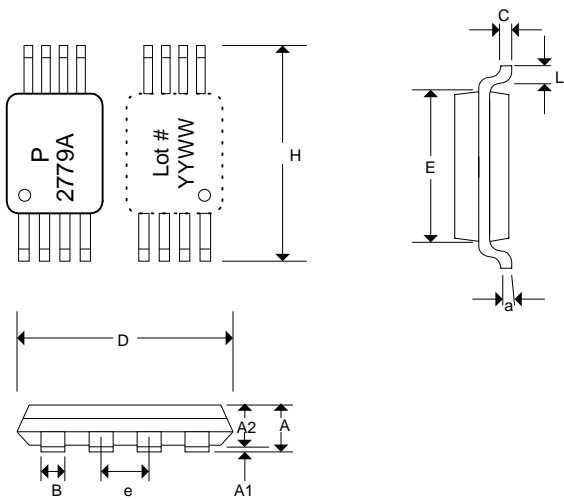

SYMBOL	INCHES			MILLIMETERS		
	MIN	NOR	MAX	MIN	NOR	MAX
A	-	-	0.047	-	-	1.10
A1	0.002	-	0.006	0.05	-	0.15
A2	0.031	0.039	0.041	0.80	1.00	1.05
B	0.007	-	0.012	0.19	-	0.30
C	0.004	-	0.008	0.09	-	0.20
D	0.114	0.118	0.122	2.90	3.00	3.10
E	0.169	0.173	0.177	4.30	4.40	4.50
e	0.026 BSC			0.65 BSC		
H	0.244	0.252	0.260	6.20	6.40	6.60
L	0.018	0.024	0.030	0.45	0.60	0.75
a	0°	-	8°	0°	-	8°

Note: Controlling dimensions are millimeters.

TSSOP - 0.034 grams unit weight



Ordering Information

X 2779A- 08 XX X

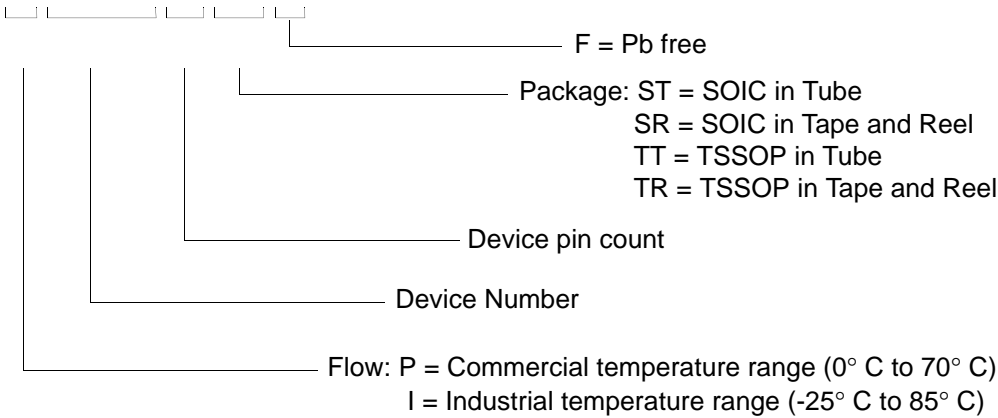

Available Ordering Numbers

Order Number	Marking	Input Frequency (MHz)	Package type	Quantity/reel	Temperature
P2779A-08ST	P2779A	20 - 38	8-pin SOIC, tube		0° C to 70° C
P2779A-08SR	P2779A	20 - 38	8-pin SOIC, tape & reel	2,500	0° C to 70° C
P2779A-08TT	P2779A	20 - 38	8-pin TSSOP, tube		0° C to 70° C
P2779A-08TR	P2779A	20 - 38	8-pin TSSOP, tape & reel	2,500	0° C to 70° C

Products are available for industrial temperature range operation. Please contact the factory for more information.

© Copyright 2003 Alliance Semiconductor Corporation. All rights reserved. Our three-point logo, our name and Intelliwatt are trademarks or registered trademarks of Alliance. All other brand and product names may be the trademarks of their respective companies. Alliance reserves the right to make changes to this document and its products at any time without notice. Alliance assumes no responsibility for any errors that may appear in this document. The data contained herein represents Alliance's best data and/or estimates at the time of issuance. Alliance reserves the right to change or correct this data at any time, without notice. If the product described herein is under development, significant changes to these specifications are possible. The information in this product data sheet is intended to be general descriptive information for potential customers and users, and is not intended to operate as, or provide, any guarantee or warranty to any user or customer. Alliance does not assume any responsibility or liability arising out of the application or use of any product described herein, and disclaims any express or implied warranties related to the sale and/or use of Alliance products including liability or warranties related to fitness for a particular purpose, merchantability, or infringement of any intellectual property rights, except as express agreed to in Alliance's Terms and Conditions of Sale (which are available from Alliance). All sales of Alliance products are made exclusively according to Alliance's Terms and Conditions of Sale. The purchase of products from Alliance does not convey a license under any patent rights, copyrights, mask works rights, trademarks, or any other intellectual property rights of Alliance or third parties. Alliance does not authorize its products for use as critical components in life-supporting systems where a malfunction or failure may reasonably be expected to result in significant injury to the user, and the inclusion of Alliance products in such life-supporting systems implies that the manufacturer assumes all risk of such use and agrees to indemnify Alliance against all claims arising from such use.