

**MOSFET 50A 450~500V**

PD7M441L PD7M440L  
P2H7M441L P2H7M440L

**PD7M441L/440L**

**P2H7M441L/440L**

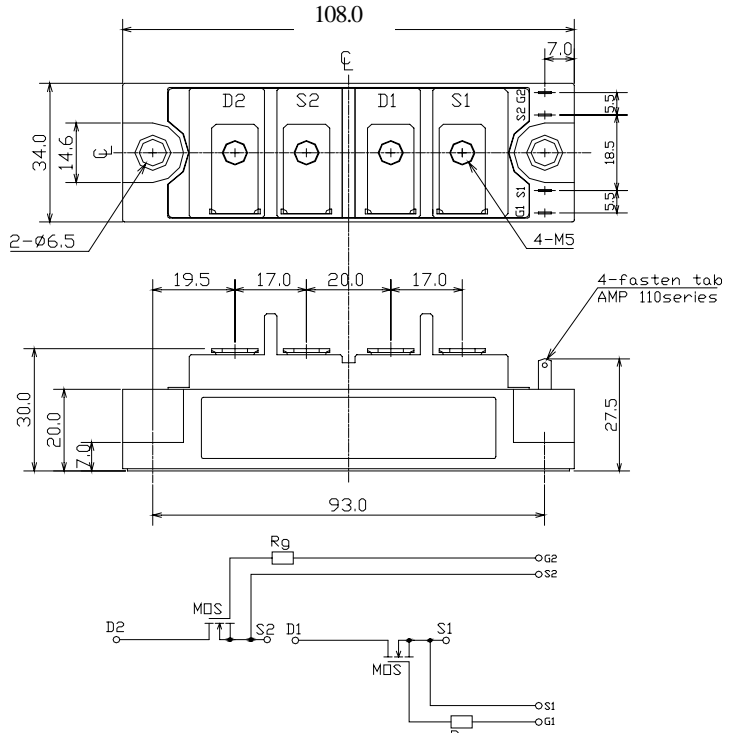
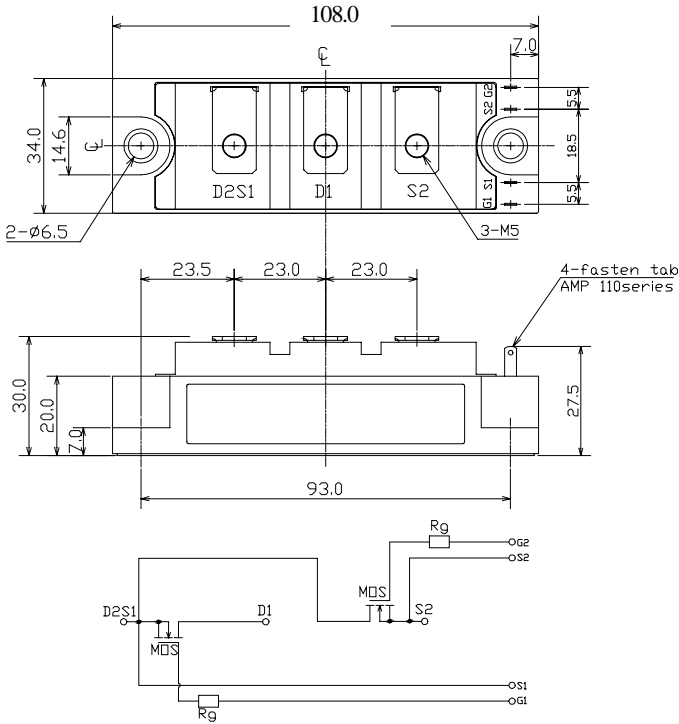

質量 Approximate Weight :220g

質量 Approximate Weight :220g

最大定格 Maximum Ratings

項目 Rating	目	記号 Symbol	耐圧・クラス Grade		単位 Unit
			PD7M441L/P2H7M441L	PD7M440L/P2H7M440L	
ドレイン・ソース間電圧 Drain-Source Voltage		$V_{DSS}$	450	500	V
			$V_{GS}=0V$		
ゲート・ソース間電圧 Gate-Source Voltage		$V_{GSS}$	± 20		V
ドレイン電流 (連続) Continuous Drain Current	Duty=50%	$I_D$	50 ( $T_c=25$ )		A
	D.C.		35 ( $T_c=25$ )		
パルスドレイン電流 Pulsed Drain Current		$I_{DM}$	100 ( $T_c=25$ )		A
全損失 Total Power Dissipation		$P_D$	350 ( $T_c=25$ )		W
動作接合温度範囲 Operating Junction Temperature Range		$T_{jw}$	- 40 ~ +150		
保存温度範囲 Storage Temperature Range		$T_{stg}$	- 40 ~ +125		
絶縁耐圧 RMS Isolation Voltage		$V_{iso}$	2000		V
			端子 - ベース間, AC1 分間 Terminals to Base, AC 1 min.		
締付トルク Mounting Torque		$F_{tor}$	3.0 ( 本体取付 Module Base to Heat sink )		N・m
			2.0 ( ネジ端子部 Bus bar to Main Terminals )		

電気的特性 Electrical Characteristics ( @Tc = 25 unless otherwise noted )

項目 Characteristic	記号 Symbol	条件 Condition	特性値(最大) Maximum Value			単位 Unit
			最小 Min.	標準 Typ.	最大 Max.	
ドレイン遮断電流 Zero Gate Voltage Drain Current	IDSS	VDS = VDSS, VGS = 0V			1	mA
		Tj = 125, VDS = VDSS, VGS = 0V			4	
ゲート・ソース間しきい値電圧 Gate-Source Threshold Voltage	VGS(th)	VDS = VGS, ID = 1mA	2	3.1	4	V
ゲート・ソース間漏れ電流 Gate-Source Leakage Current	IGSS	VGS = ±20V, VDS = 0V			1	μA
ドレイン・ソース間オン抵抗 (MOSFET部) Static Drain-Source On-Resistance	rDS(on)	VGS = 10V, ID = 25A		110	120	m
順伝達コンダクタンス Forward Transconductance	gfg	VDS = 15V, ID = 25A		45		S
入力容量 Input Capacitance	Ciss	VGS = 0V VDS = 25V f = 1MHz		9.0		nF
出力容量 Output Capacitance	Coss			1.7		nF
帰還容量 Reverse Transfer Capacitance	Crss			0.32		nF
ターン・オン遅延時間 Turn-On Delay Time	tD(on)			120		ns
上昇時間 Rise Time	tr		VDD = 1/2VDSS ID = 25A		80	
ターン・オフ遅延時間 Turn-Off Delay Time	tD(off)	VGS = -5V, +10V RG = 7		240		ns
下降時間 Fall Time	tf			50		ns

内部ダイオード定格・特性 Source-Drain Diode Ratings and Characteristics ( @Tc = 25 unless otherwise noted )

項目 Characteristic	記号 Symbol	条件 Condition	特性値(最大) Maximum Value			単位 Unit
			最小 Min.	標準 Typ.	最大 Max.	
ソース電流 (連続) Continuous Source Current	IS	D. C.			35	A
パルスソース電流 Pulsed Source Current	ISM				100	A
ダイオード順電圧 Diode Forward Voltage	VSD	IS = 50A			2	V
逆回復時間 Reverse Recovery Time	trr	IS = 50A - dis/dt = 100A/μs		900		ns
逆回復電荷 Reverse Recovery Charge	Qr			25		μC

熱抵抗特性 Thermal Characteristics

項目 Characteristic	記号 Symbol	条件 Condition	特性値(最大) Maximum Value			単位 Unit
			最小 Min.	標準 Typ.	最大 Max.	
熱抵抗 (接合部 - ケース間) Thermal Resistance, Junction to Case	Rth(j-c)	MOSFET			0.36	/W
		Diode			0.36	
接触熱抵抗 (ケース - 冷却フィン間) Thermal Resistance, Case to Heatsink	Rth(c-f)	サーマルコンパウンド塗布 Mounting surface flat, smooth, and greased			0.1	

Fig. 1 Typical Output Characteristics

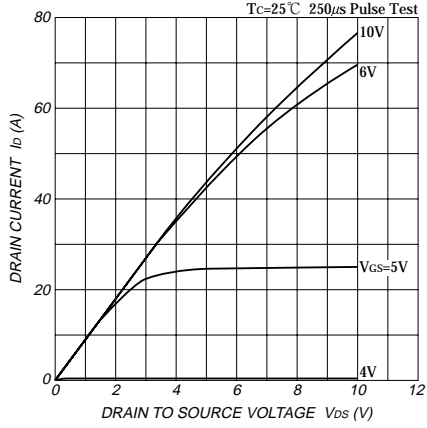

Fig. 2 Typical Drain-Source On-Voltage Vs. Gate-Source Voltage

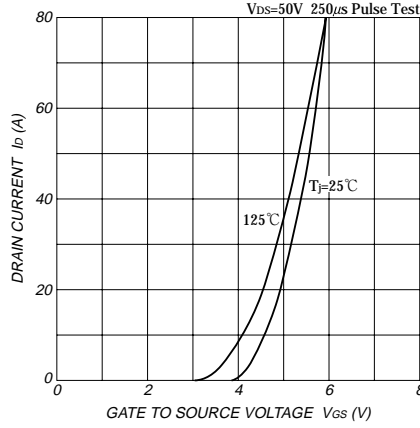

Fig. 3 Typical Drain-Source On Voltage Vs. Junction Temperature

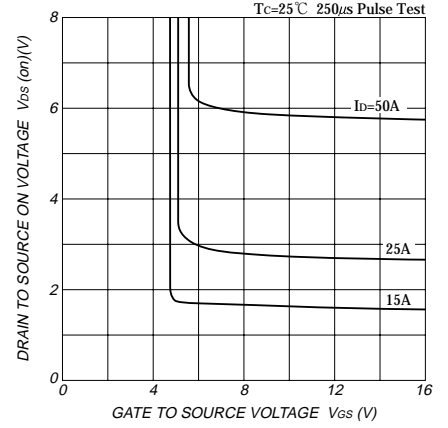

Fig. 4 Typical Capacitance Vs. Drain-Source Voltage

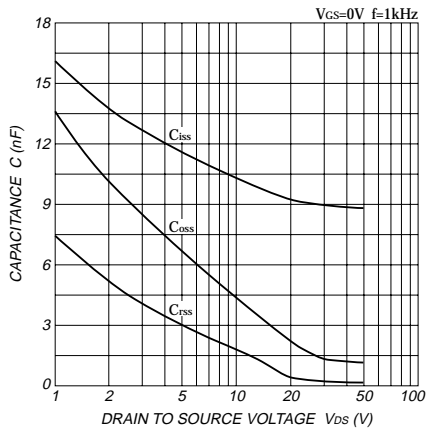

Fig. 5 Typical Gate Charge Vs. Gate-Source Voltage

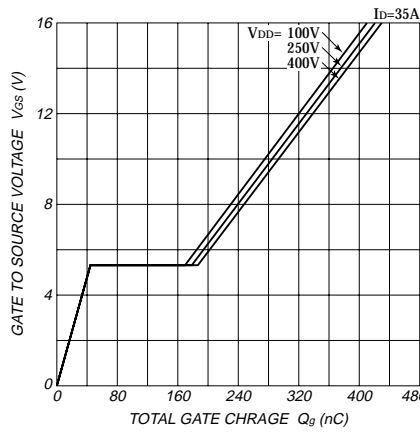

Fig. 6 Typical Switching Time Vs. Series Gate Impedance

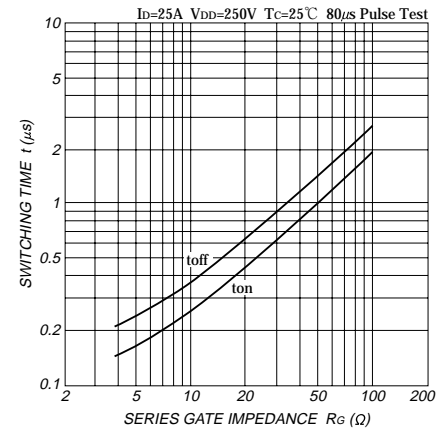

Fig. 7 Typical Switching Time Vs. Drain Current

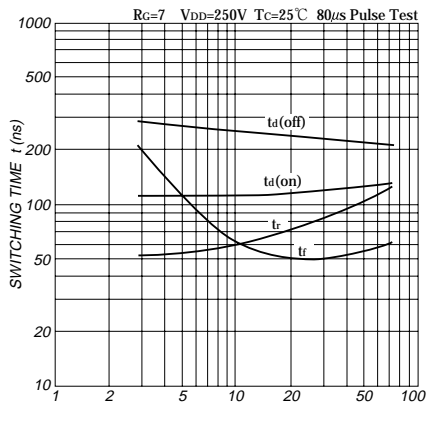

Fig. 8 Typical Source-Drain Diode Forward Characteristics

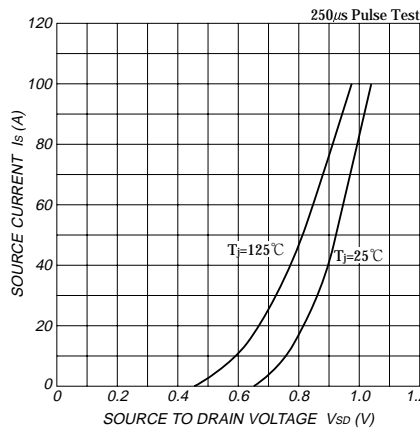

Fig. 9 Typical Reverse Recovery Characteristics

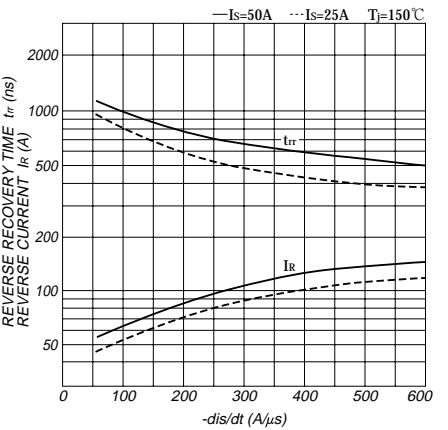

Fig. 10 Maximum Safe Operating Area

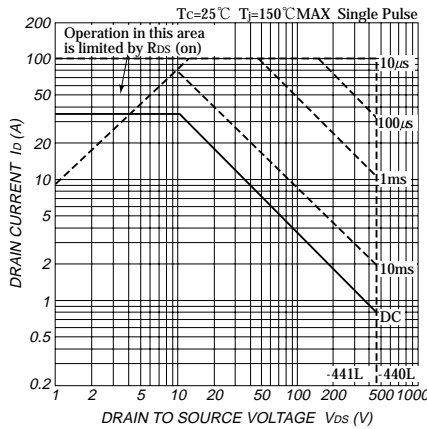

Fig. 11 Normalized Transient Thermal Impedance(MOSFET)

