

PNP SILICON PLANAR EPITAXIAL TRANSISTORS

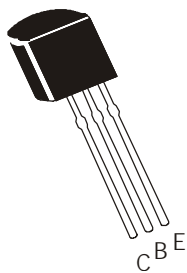

**P2N2907
P2N2907A**

**TO-92
Plastic Package**

Designed for switching and linear applications, DC amplifier and driver for industrial applications

ABSOLUTE MAXIMUM RATINGS ($T_a=25^\circ\text{C}$ Unless Specified Otherwise)

| DESCRIPTION | SYMBOL | P2N2907 | P2N2907A | UNIT |
|--|----------------|--------------|----------|----------------------|
| Collector Emitter Voltage | V_{CEO} | 40 | 60 | V |
| Collector Base Voltage | V_{CBO} | 60 | 60 | V |
| Emitter Base Voltage | V_{EBO} | 5 | | V |
| Collector Current | I_{CM} | 600 | | mA |
| Total Power Dissipation @ $T_a=25^\circ\text{C}$ | P_D | 625 | | mW |
| Derate above 25°C | | 5 | | mW/ $^\circ\text{C}$ |
| Total Power Dissipation @ $T_c=25^\circ\text{C}$ | P_D | 1.5 | | W |
| Derate above 25°C | | 12 | | mW/ $^\circ\text{C}$ |
| Operating and Storage Junction Temperature Range | T_j, T_{stg} | - 55 to +150 | | $^\circ\text{C}$ |

THERMAL RESISTANCE

| | | | |
|---------------------|---------------|------|--------------------|
| Junction to Case | $R_{th(j-c)}$ | 83.3 | $^\circ\text{C/W}$ |
| Junction to Ambient | $R_{th(j-a)}$ | 200 | $^\circ\text{C/W}$ |

ELECTRICAL CHARACTERISTICS ($T_a=25^\circ\text{C}$ Unless Specified Otherwise)

| DESCRIPTION | SYMBOL | TEST CONDITION | P2N2907 | P2N2907A | UNIT |
|--------------------------------------|----------------|---|---------|----------|---------------|
| Collector Emitter Voltage | $*V_{CEO}$ | $I_C=10\text{mA}, I_B=0$ | >40 | >60 | V |
| Collector Base Voltage | V_{CBO} | $I_C=10\mu\text{A}, I_E=0$ | >60 | >60 | V |
| Emitter Base Voltage | V_{EBO} | $I_E=10\mu\text{A}, I_C=0$ | >5 | >5 | V |
| Collector Cut off Current | I_{CBO} | $V_{CB}=50\text{V}, I_E=0$ | <20 | <10 | nA |
| | I_{CEX} | $V_{CB}=50\text{V}, I_E=0, T_a=150^\circ\text{C}$ | <20 | <10 | μA |
| | I_{CEO} | $V_{CE}=30\text{V}, V_{EB(off)}=0.5\text{V}$ | <50 | <50 | nA |
| Emitter Cut off Current | I_{EBO} | $V_{CE}=10\text{V}, I_B=0$ | <10 | <10 | nA |
| | | $V_{EB}=3\text{V}, I_C=0$ | <10 | <10 | nA |
| Base Cut off Current | I_{BEX} | $V_{CE}=30\text{V}, V_{EB(off)}=0.5\text{V}$ | <50 | <50 | nA |
| Collector Emitter Saturation Voltage | $*V_{CE(sat)}$ | $I_C=150\text{mA}, I_B=15\text{mA}$ | <0.4 | <0.4 | V |
| | | $I_C=500\text{mA}, I_B=50\text{mA}$ | <1.6 | <1.6 | V |
| Base Emitter Saturation Voltage | $*V_{BE(sat)}$ | $I_C=150\text{mA}, I_B=15\text{mA}$ | <1.3 | <1.3 | V |
| | | $I_C=500\text{mA}, I_B=50\text{mA}$ | <2.6 | <2.6 | V |

PNP SILICON PLANAR EPITAXIAL TRANSISTORS

P2N2907
P2N2907A

TO-92
Plastic Package

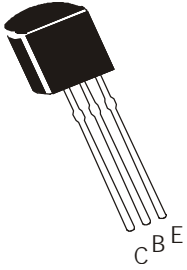

ELECTRICAL CHARACTERISTICS ($T_a=25^\circ\text{C}$ Unless Specified Otherwise)

| DESCRIPTION | SYMBOL | TEST CONDITION | P2N2907 | P2N2907A | UNIT |
|--------------------------------|----------|--|-----------|-----------|------|
| DC Current Gain | h_{FE} | $I_C=0.1\text{mA}, V_{CE}=10\text{V}$ | >35 | >75 | |
| | | $I_C=1\text{mA}, V_{CE}=10\text{V}$ | >50 | >100 | |
| | | $I_C=10\text{mA}, V_{CE}=10\text{V}$ | >75 | >100 | |
| | | $I_C=150\text{mA}, V_{CE}=10\text{V}^*$ | 100 - 300 | 100 - 300 | |
| | | $I_C=500\text{mA}, V_{CE}=10\text{V}^*$ | >30 | >50 | |
| DYNAMIC CHARACTERISTICS | | | | | |
| Transition Frequency | f_T | $I_C=50\text{mA}, V_{CE}=20\text{V},$ $f=100\text{MHz}$ | >200 | >200 | MHz |
| Output Capacitance | C_{ob} | $V_{CB}=10\text{V}, I_E=0, f=1\text{MHz}$ | <8 | <8 | pF |
| Input Capacitance | C_{ib} | $V_{EB}=2\text{V}, I_C=0, f=1\text{MHz}$ | <30 | <30 | pF |

SWITCHING CHARACTERISTICS

| | | | | | |
|---------------|-----------|---|------|------|----|
| Delay Time | t_d | $I_C=150\text{mA}, I_{B1}=15\text{mA},$ $V_{CC}=30\text{V}$ | <10 | <10 | ns |
| Rise Time | t_r | | <40 | <40 | ns |
| Turn-on Time | t_{on} | | <50 | <50 | ns |
| Storage Time | t_s | $I_C=150\text{mA}, I_{B1}=15\text{mA},$ $I_{B2}=15\text{mA}, V_{CC}=6\text{V}$ | <80 | <80 | ns |
| Fall Time | t_f | | <30 | <30 | ns |
| Turn-off Time | t_{off} | | <110 | <110 | ns |

* Pulse condition: Pulse Width $\leq 300\mu\text{s}$, Duty cycle $\leq 1\%$

**P2N2907
P2N2907A**

**TO-92
Plastic Package**

TO-92 Plastic Package

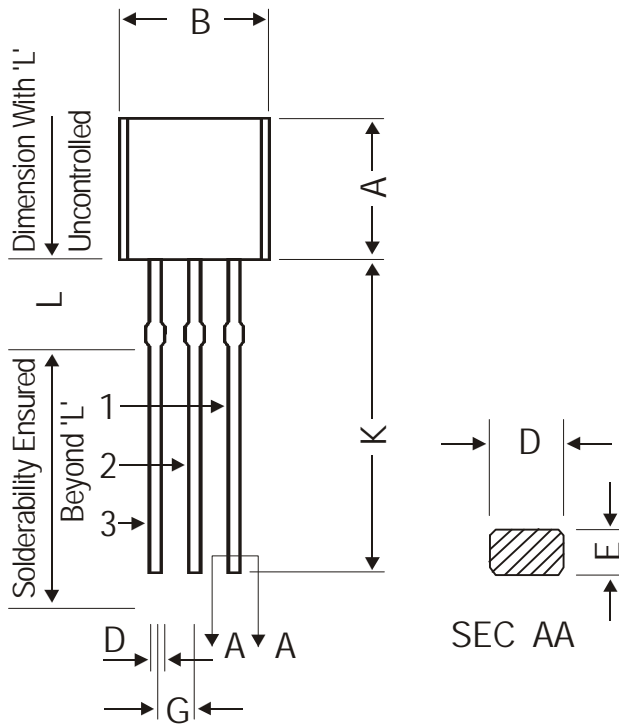

| DIM | MIN. | MAX. |
|-----|-------|-------|
| A | 4.32 | 5.33 |
| B | 4.45 | 5.20 |
| C | 3.18 | 4.19 |
| D | 0.41 | 0.55 |
| E | 0.35 | 0.50 |
| F | 5 DEG | |
| G | 1.14 | 1.40 |
| H | 1.20 | 1.40 |
| K | 12.70 | — |
| L | 1.982 | 2.082 |
| M | 1.03 | 1.20 |

All dimensions are in mm

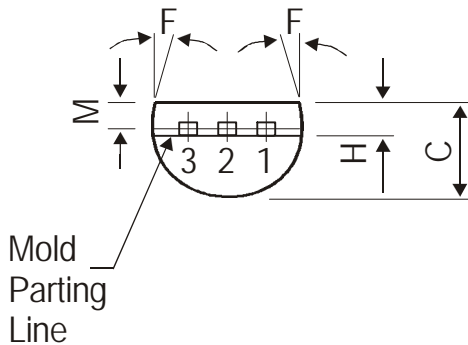

PIN CONFIGURATION

1. EMITTER
2. BASE
3. COLLECTOR

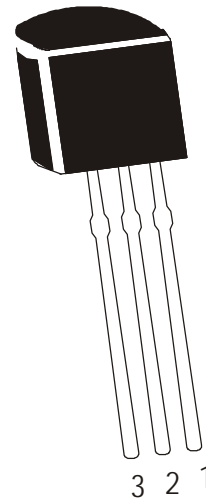

The TO-92 Package , Tape and Ammo Pack drawings are correct as on the date of issue/revision of this Data Sheet.

The currently valid dimensions and information, may please be confirmed from the TO-92 Drawing in the Packages and

Packing Section of the Product Catalogue.

Packing Details

| PACKAGE | STANDARD PACK | | INNER CARTON BOX | | OUTER CARTON BOX | | |
|------------|---------------|----------------|-------------------|-----|-------------------|-----|----------|
| | Details | Net Weight/Qty | Size | Qty | Size | Qty | Gr/Wt |
| TO-92 Bulk | 1K/polybag | 200 gm/1K pcs | 3" x 7.5" x 7.5" | 5K | 17" x 15" x 13.5" | 80K | 23 kgs |
| TO-92 T&A | 2K/ammo box | 645 gm/2K pcs | 12.5" x 8" x 1.8" | 2K | 17" x 15" x 13.5" | 32K | 12.5 kgs |

TO-92 Tape and Ammo Pack

Tape Mechanical Data

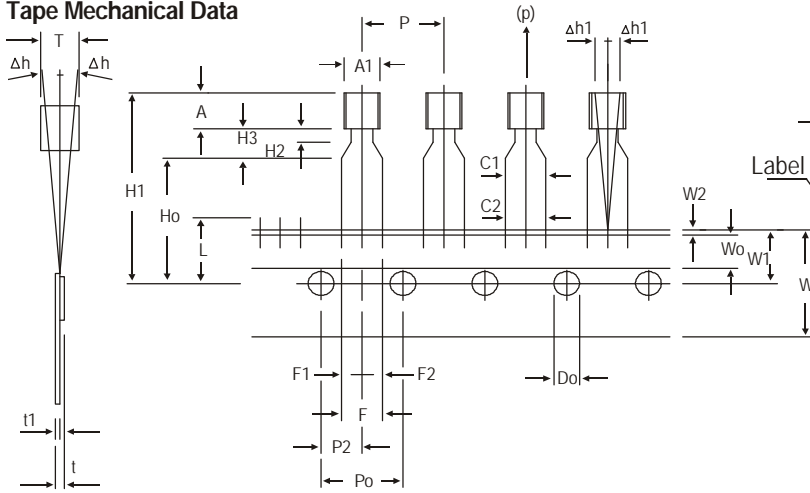

Ammo Pack Style

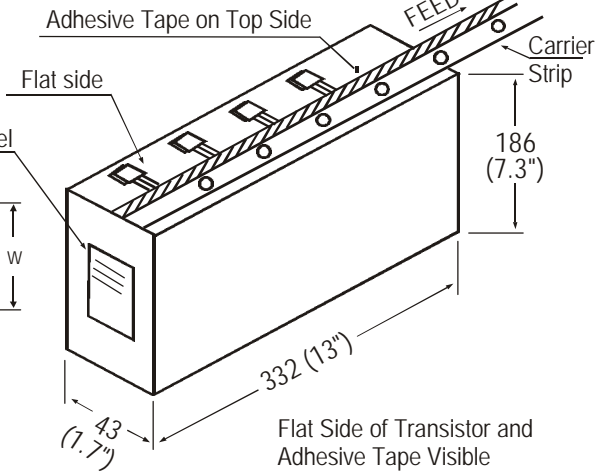

Flat Side of Transistor and Adhesive Tape Visible
2000 pcs./Ammo Pack

All dimensions are in mm

| ITEM | SYMBOL | SPECIFICATION | | | |
|---|---------|---------------|------|-------|----------------|
| | | MIN. | NOM. | MAX. | TOL. |
| BODY WIDTH | A1 | 4.0 | | 4.8 | |
| BODY HEIGHT | A | 4.8 | | 5.2 | |
| BODY THICKNESS | T | 3.9 | | 4.2 | |
| PITCH OF COMPONENT | P | | 12.7 | | ± 1.0 |
| *1 FEED HOLE PITCH | Po | | 12.7 | | ± 0.3 |
| *2 FEED HOLE CENTRE TO COMPONENT CENTRE | P2 | | 6.35 | | ± 0.4 |
| DISTANCE BETWEEN OUTER LEADS | F | | 5.08 | | + 0.6 - 0.2 |
| *3 COMPONENT ALIGNMENT SIDE VIEW | Δh | | 0 | 1.0 | |
| *4 COMPONENT ALIGNMENT FRONT VIEW | Δh1 | | 0 | 1.3 | |
| TAPE WIDTH | W | | 18 | | ± 0.5 |
| HOLD-DOWN TAPE WIDTH | W0 | | 6 | | ± 0.2 |
| HOLE POSITION | W1 | | 9 | | + 0.7 - 0.5 |
| HOLD-DOWN TAPE POSITION | W2 | | 0.5 | | ± 0.2 |
| LEAD WIRE CLINCH HEIGHT | Ho | | 16 | | ± 0.5 |
| COMPONENT HEIGHT | H1 | | | 23.25 | |
| LENGTH OF SNIPPED LEADS | L | | | 11.0 | |
| FEED HOLE DIAMETER | Do | | 4 | | ± 0.2 |
| *5 TOTAL TAPE THICKNESS | t | | | 1.2 | |
| LEAD - TO - LEAD DISTANCE | F1, F2 | | 2.54 | | + 0.4 - 0.1 |
| STAND OFF | H2 | 0.45 | | 1.45 | |
| CLINCH HEIGHT | H3 | | | 3.0 | |
| LEAD PARALLELISM | C1 - C2 | | | 0.22 | |
| PULL - OUT FORCE | (p) | 6N | | | |

NOTES

1. Maximum alignment deviation between leads will not to be greater than 0.2mm.
2. Maximum non-cumulative variation between tape feed holes shall not exceed 1 mm in 20 pitches.
3. Holddown tape will not exceed beyond the edge(s) of carrier tape and there shall be no exposure of adhesive.
4. There will be no more than three (3) consecutive missing components in a tape.
5. A tape trailer, having at least three feed holes are provided after the last component in a tape.
6. Splices should not interfere with the sprocket feed holes.

REMARKS

- *1 Cumulative pitch error 1.0 mm/20 pitch
- *2 To be measured at bottom of clinch
- *3 At top of body
- *4 At top of body
- *5 t1 0.3 – 0.6 mm

Disclaimer

The product information and the selection guides facilitate selection of the CDIL's Discrete Semiconductor Device(s) best suited for application in your product(s) as per your requirement. It is recommended that you completely review our Data Sheet(s) so as to confirm that the Device(s) meet functionality parameters for your application. The information furnished in the Data Sheet and on the CDIL Web Site/CD are believed to be accurate and reliable. CDIL however, does not assume responsibility for inaccuracies or incomplete information. Furthermore, CDIL does not assume liability whatsoever, arising out of the application or use of any CDIL product; neither does it convey any license under its patent rights nor rights of others. These products are not designed for use in life saving/support appliances or systems. CDIL customers selling these products (either as individual Discrete Semiconductor Devices or incorporated in their end products), in any life saving/support appliances or systems or applications do so at their own risk and CDIL will not be responsible for any damages resulting from such sale(s).

CDIL strives for continuous improvement and reserves the right to change the specifications of its products without prior notice.



CDIL is a registered Trademark of
Continental Device India Limited

C-120 Naraina Industrial Area, New Delhi 110 028, India.

Telephone + 91-11-2579 6150, 5141 1112 Fax + 91-11-2579 5290, 5141 1119
email@cdil.com www.cdilsemi.com