



P0080~P3500TA Serie

Description

P0060~P3500TA_B_C Series are low capacitance devices designed to protect broadband equipment such as VOIP, DSL modems and DSLAMs from damaging overvoltage transients.

The series provides a surface mount solution that enables equipment to comply with global regulatory standards while limiting the impact to broadband signals.



Features and Benefits

- Low voltagr overshoot
- Low on-state voltage
- Does not degrade with use
- Fails short circuit when surged in excess of ratings
- Low Capacitance

Applicable Global Standards

- TIA-968-A
- ITU K.20/21 Enhanced level*
- ITU K.20/21 Basic Level
- GR 1089 Inter building*
- GR 1089 Inter building
- IEC 6100-4-5
- YD/T 1082
- YD/T 993
- YD/T 950

Product Name

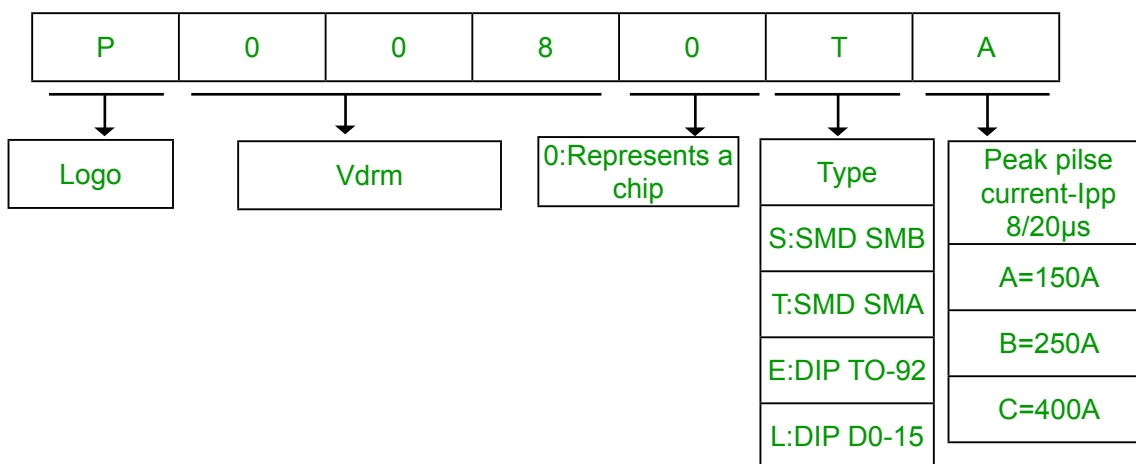



P0080~P3500TA Serie

Electrical Characteristics (@ TA = 25 °C Unless Otherwise Noted)

Part Number	V _{DRM} Volts	V _S Volts	V _T Volts	I _{DRM} μAmps	I _S mAmps	I _T Amps	I _H mAmps	C _O pF
P0080TA	6	25	4	5	800	2.2	50	50
P0300TA	25	40	4	5	800	2.2	50	70
P0640TA	58	77	4	5	800	2.2	150	50
P0720TA	65	88	4	5	800	2.2	150	50
P0900TA	75	98	4	5	800	2.2	150	45
P1100TA	90	130	4	5	800	2.2	150	45
P1300TA	120	160	4	5	800	2.2	150	45
P1500TA	140	180	4	5	800	2.2	150	40
P1800TA	170	220	4	5	800	2.2	150	40
P2300TA	190	260	4	5	800	2.2	150	35
P2600TA	220	300	4	5	800	2.2	150	35
P3100TA	275	350	4	5	800	2.2	150	30
P3500TA	320	400	4	5	800	2.2	150	30

Notes:
 - Absolute maximum ratings measured at T_A= 25°C (unless otherwise noted).
 - Devices are bi-directional.

SERIES	Peak Pulse Current-I _{pp} (A)				
	2/10μs	8/20μs	10/160μs	10/560μs	10/1000μs
A	200	150	100	60	50

Dimensions

DO-214AC/SMA

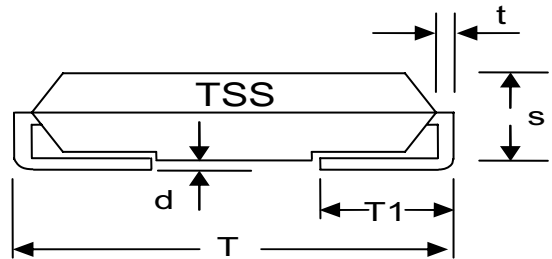
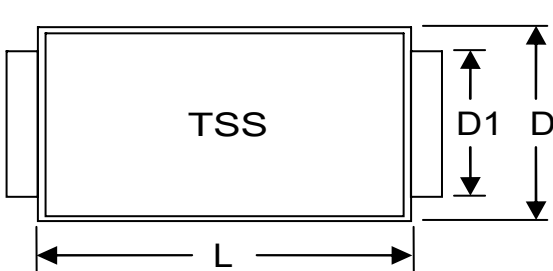

Item	Millimeters		Inches	
	Min.	Max.	Min.	Max.
L	3.99	4.50	0.157	0.177
D	2.54	2.79	0.100	0.110
D1	1.25	1.65	0.049	0.065
T	4.93	5.28	0.194	0.208
T1	0.76	1.52	0.030	0.060
D	-	0.203	-	0.008
S	1.98	2.29	0.076	0.090
t	0.152	0.305	0.006	0.012



P0080~P3500TA Serie

Thermal Considerations

Package SMA	Symbol	Parameter	Value	Unit
	TJ	Operating Junction Temperature	-40 to +150	°C
	TS	Storage Temperature Range	-40 to +150	°C
	RθJA	Junction to Ambient on printed circuit	90	°C/W

V-I Characteristics

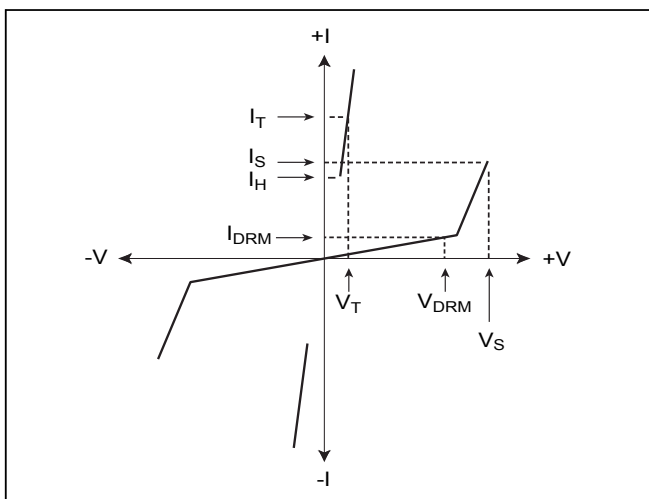

V-I Characteristics

$t_r \times t_d$ Pulse Waveform

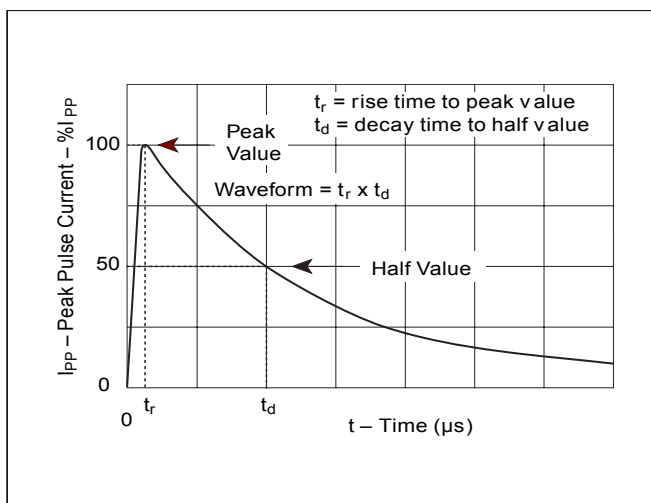

$t_r \times t_d$ Pulse Wave-form

Normalized V_S Change vs. Junction Temperature

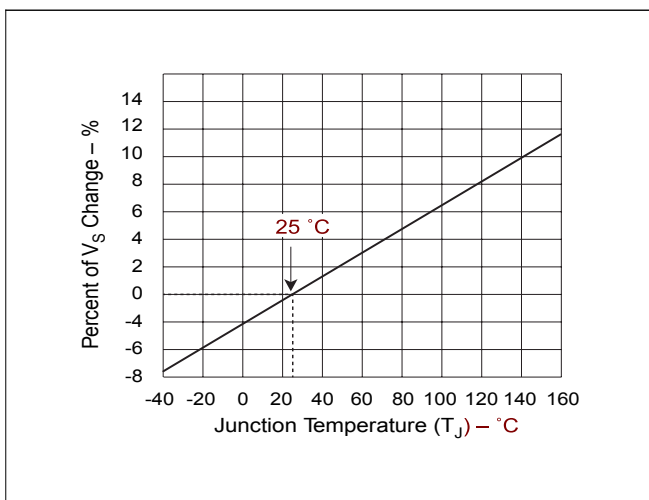

Normalized V_S Change versus Junction Temperature

Normalized DC Holding Current vs. Case Temperature

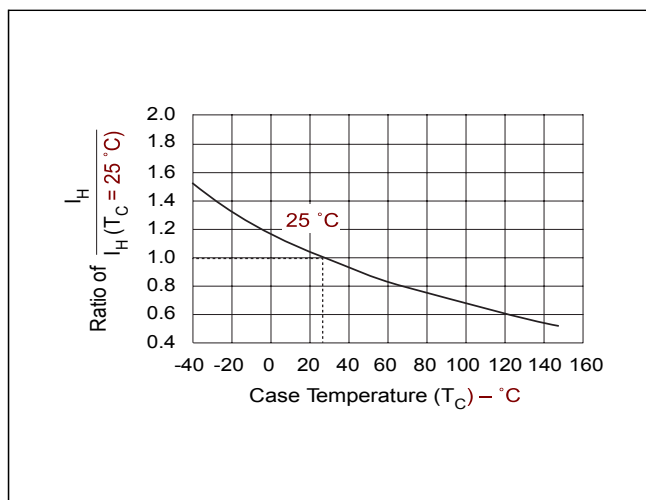

Normalized DC Holding Current versus Case Temperature



P0080~P3500TA Serise

Figure 1.Examples of protection stages for line cards

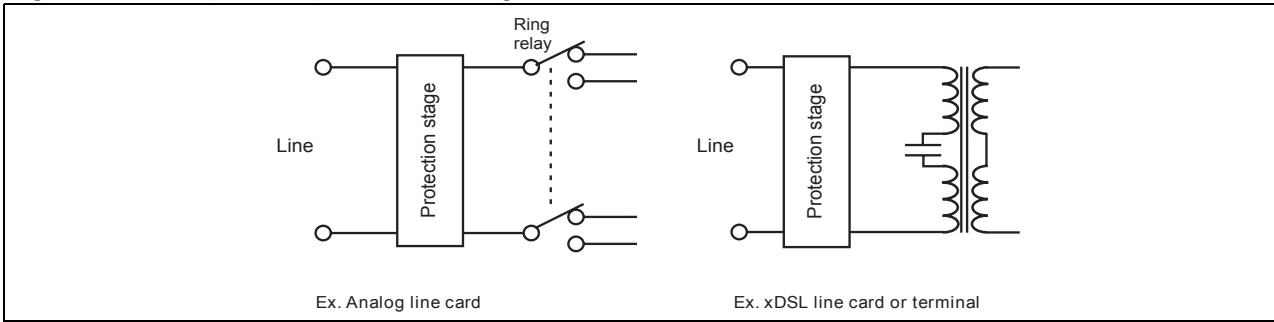

In such a stage, parallel function is assumed by one or several Trisil, and is used to protect against short duration surge (lightning). During this kind of surges the Trisil limits the voltage across the device to be protected at its break over value and then fires. The fuse assumes the series function, and is used to protect the module against long duration or very high current mains disturbances (50/60Hz). It acts by safe circuit opening. Lightning surge and mains disturbance surges are defined by standards like GR1089, FCC part 68, ITU-T K20.

Figure 2. Typical circuits

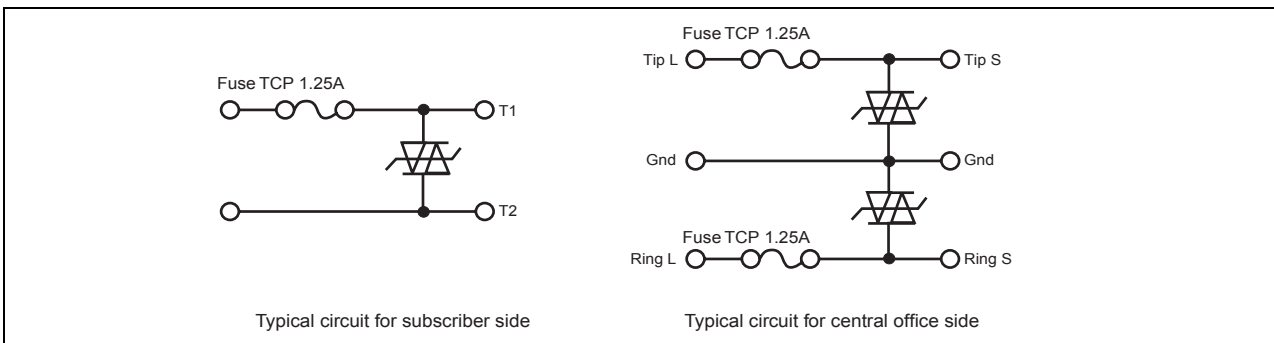
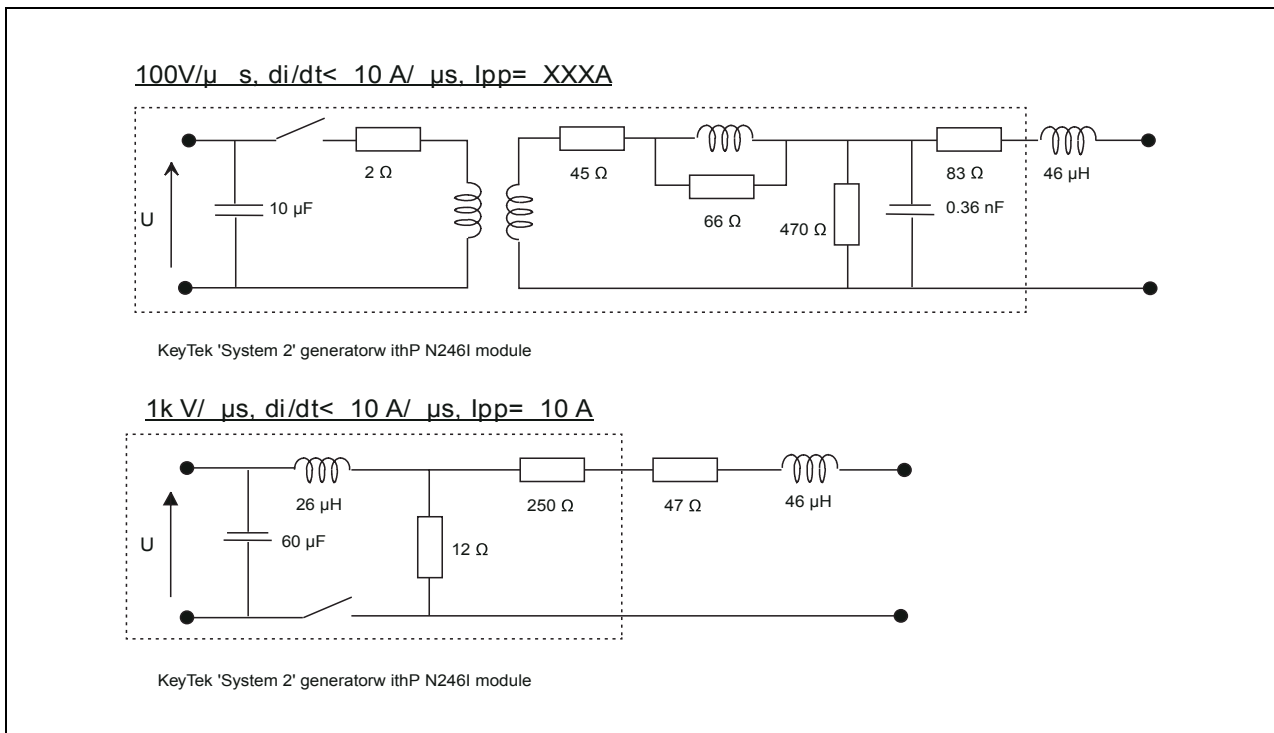

Figure 3.Test circuit 1 for Dynamic IBO and VBO parameter s





P0080~P3500TA Serise

Figure 4. Test circuit 3 for dynamic I_H parameter

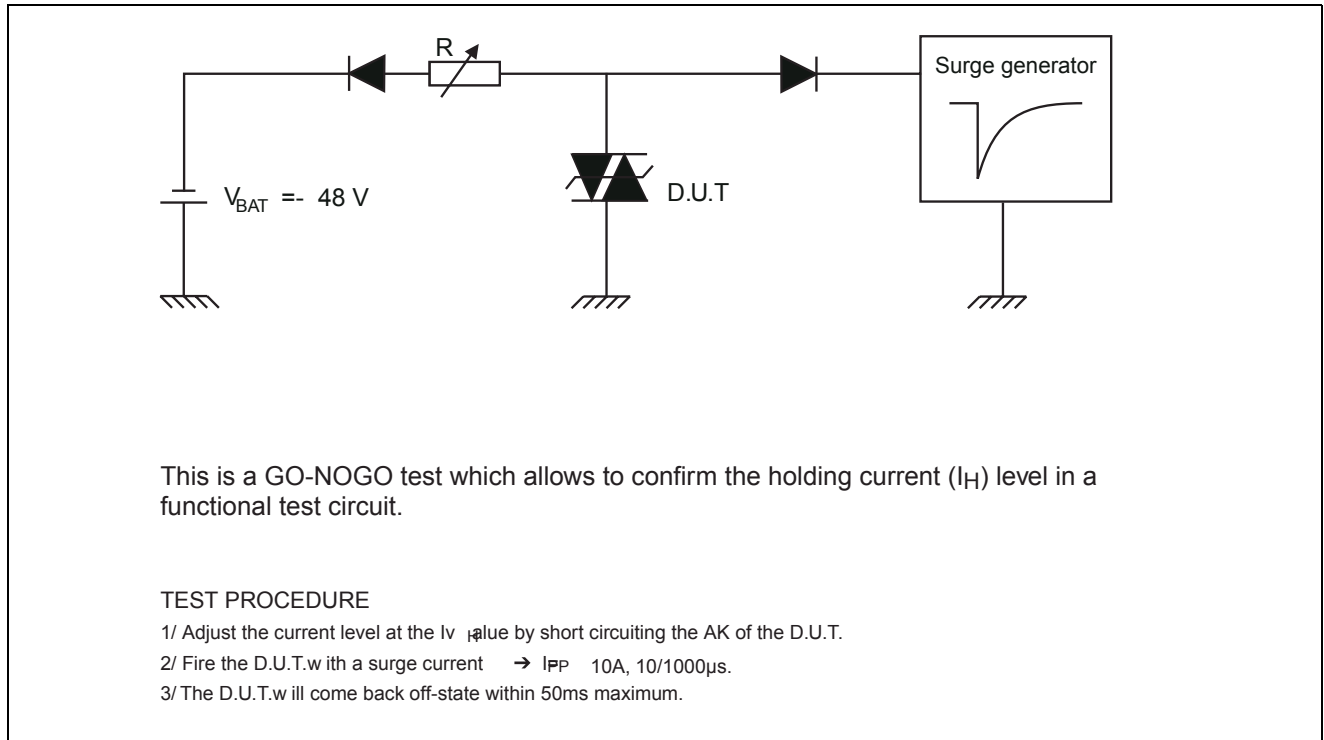

Figure 5. Test circuit 2 for I_{BO} and V_{BO} parameters

