

Version : 0.0(***Preliminary***)

TECHNICAL SPECIFICATION

MODEL NO. : P35EN1A001

Customer's Confirmation

Date _____

By _____

PVI's Confirmation

Confirmed By _____

Prepared By _____

PRIME VIE INTERNATIONAL CO.,LTD.

3,LI SHIN RD. 1,SCIENCE-BASED INDUSTRIAL
PARK,HSINCHU,TAIWAN,R.O.C.

<http://www.pvi.com.tw>

Date : March 03,2000

This technical specification is subject to change without notice.
Please return 1 copy with your signature on this page for approval.

TECHNICAL SPECIFICATION**CONTENTS**

NO.	ITEM	PAGE
-	Cover	1
-	Contents	2
1	Application	3
2	Features	3
3	Mechanical Specifications	3
4	Mechanical Drawing of TFT-LCD module	4
5	Input / Output Terminals	5
6	Absolute Maximum Ratings	7
7	Electrical Characteristics	7
8	Optical Characteristics	12
9	Reliability Test	15
10	Block Diagram	16
-	Appendix A : Interface Circuit	17
-	Revision History	20

1. Application

This specification applies to 3.5" color TFT-LCD panel. The 3.5" color TFT LCD panel is designed for camcorder, video phone application and other electronic products which require high quality flat panel displays.

2. Features

- . No controller chip is necessary
- . Compatible with NTSC and PAL system
- . High Resolution : 140400 Dots (600 × 234)
- . High transmittance Ratio : 8.0 %
- . Optimum Viewing Direction : 6 o'clock
- . Up/ Down and Left/Right Image Reversion
- . Surface treatment : Anti-Glare

3. Mechanical Specifications

Parameter	Specifications	Unit
Screen Size	3.5 (diagonal)	inch
Display Format	600×234	dot
Active Area	71.7 (H) X 52.4(V)	mm ²
Dot Pitch	0.119 (H)×0.224 (V)	mm ²
Pixel Configuration	Delta	
Outline Dimension	See Mechanical Drawing	mm ³
Weight	59	g

4. Mechanical Drawing

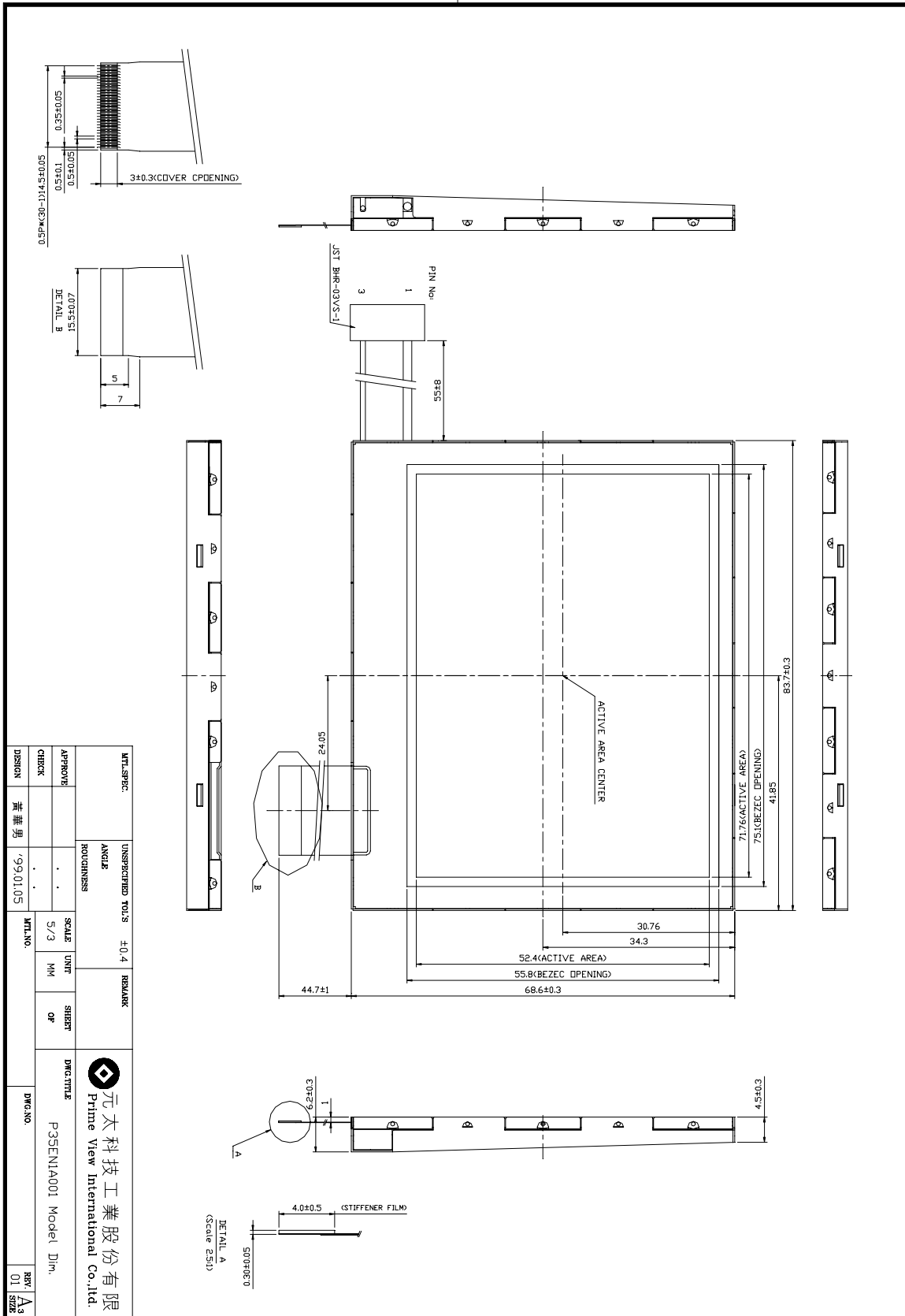

5. Input / Output Terminals

Pin No	Symbol	I/O	Description	Remark
1	V_{COM}	I	Common Electrode Voltage	Note 5-1
2	V_{BBA}	I	Supply Voltage for Level Shifter (Low Level)	Note 5-2
3	NC		No Connection	
4	V_{BBC}	I	Supply voltage for panel	Note 5-2
5	V_{SS}	I	Ground for panel	
6	V_{CC}	I	Supply Voltage for Level Shifter (High Level)	Note 5-4
7	V_{PIN}	I	Pulse high level for Level Shifter (High Level)	Note 5-5
8	V_{MIN}	I	Pulse low level for Level Shifter (Low Level)	Note 5-5
9	FRP	O	Control Signal for Video Inversion	
10	\overline{VSY}	I/O	Vertical Sync.	
11	\overline{HSY}	I/O	Horizontal Sync.	
12	C_{SYNC}	I	Composite Sync.	
13	PD	O	Phase Detector	Note 5-6
14	OSC	I	Clock Input for LC Oscillator	Note 5-6
15	V_{DD}	I	Supply Voltage for Logic Circuit	Note 5-3
16	CKC	I	Control Pin for Select I/O Signal	Note 5-12
17	UD	I	Up / Down Control	Note 5-11
18	LR	I	Left / Right Shift Control	Note 5-7
19	NP	I	NTSC / PAL Selector	Note 5-8
20	V_B	I	Video Input B	
21	V_G	I	Video Input G	
22	V_R	I	Video Input R	
23	GND	I	Ground for High voltage logic	
24	GND	I	Ground for logic	
25	DV_{EE}	I	Voltage supply for source driver high logic	Note 5-9
26	C_{COM}	I	Reference for Sample and Hold	Note 5-10
27	AV_{EE}	I	Voltage supply for sample & hold	Note 5-9
28	GND	I	Ground	
29	OV_{EE}	I	Voltage supply for operation amplifier	Note 5-9
30	VP+	I	Pre-charge high level	Note 5-9

Note 5-1 : V_{COM} should be adjusted accurately to get the best contrast ratio.

Note 5-2 : $V_{BBA}, V_{BBC} = -5V$ (Typ.)

Note 5-3 : $V_{DD}, PV_{DD} = +5V$ (Typ.)

Note 5-4 : $V_{CC}=+20V(Typ.)$

Note 5-5 : V_{PIN} must be more positive than V_{MIN} .

Pin	Symbol	min	Typ.	Max.	Unit
7	V_{PIN}	12	13	14	V
8	V_{MIN}	5	6	7	V

Note 5-6 : PD output(0~5V range) from phase detector loop which is included in source driver.

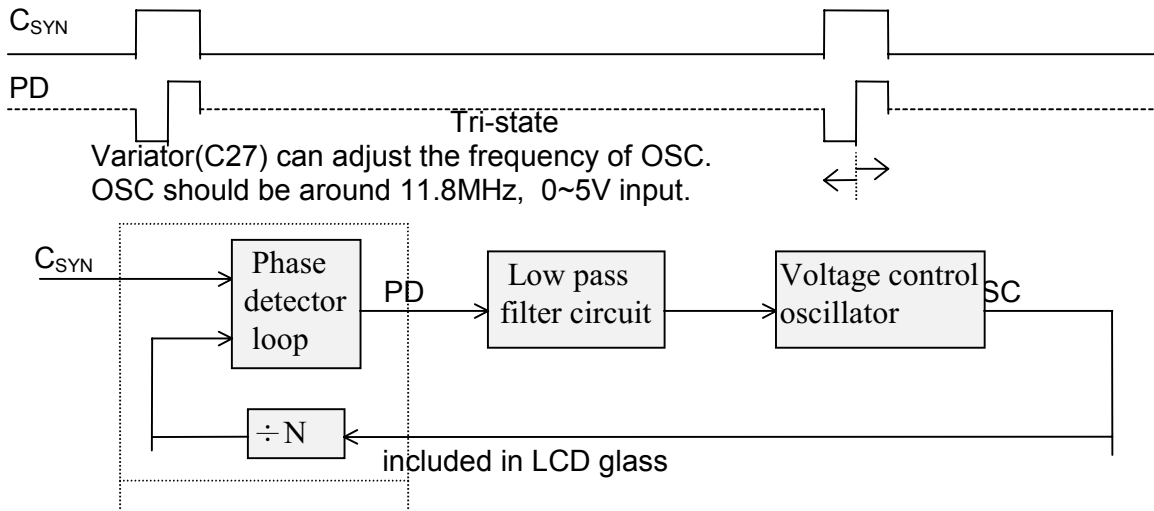

Note 5-7 : Left / Right SHIFT .

Note 5-8 : Hi (+5V) for NTSC : Low (0V) for PAL.

Note 5-9 : $DV_{EE}, AV_{EE}, OV_{EE}$ and $VP+$ all equal to +14V

Note 5-10 : $C_{COM} \doteq +5V (Typ.)$

Note 5-11 : UP / Down Shift

Note 5-12 : Pin 16(CKC) can select the function for Pin 11(\overline{HSY}) and Pin 10(\overline{VSY}).

CKC	\overline{HSY}	CSY	\overline{VSY}
Hi	\overline{HSY} Output	CSY Input	\overline{VSY} Output
Low	External \overline{HSY} Input	External Clock Input	External \overline{VSY} Input

6. Absolute Maximum Ratings:

GND = 0 V , Ta = 25 °C

Parameter		Symbol	MIN.	MAX.	Unit	Remark
Supply Voltage for Source Driver		DV _{EE} , AV _{EE} OV _{EE} , VP+	0	+16	V	
Supply Voltage for Gate Driver	H Level	V _{CC}	0	+26	V	
	L Level	V _{BBA} , V _{BBC}	-7	+20	V	
Supply voltage for controller		V _{DD}	0	+6.5	V	
DC bias voltage of common electrode		V _{com}	+2	+6	V	
Analog input signals		V _B , V _R , V _G	0	+12	V	

7. Electrical Characteristics
7-1) Recommended Operating Conditions:
A) Driving for TFT-LCD panel

GND = 0V , Ta = 25 °C

Parameter		Symbol	MIN.	TYP	MAX.	Unit	Remark
Supply voltage for source driver		DV _{EE} , AV _{EE} OV _{EE} , VP+	+13.5	+14	+14.5	V	
Supply voltage for gate driver	H Level	V _{CC}	+19	+20	+24	V	
	L level	V _{BBA} , V _{BBC}	-5.5	-5	-4	V	
Supply voltage for controller		V _{DD}	+4.7	+5	+5.3	V	
Analog input voltage	Amplitude	V _B , V _R , V _G	+1.12		12	V	
	DC component		+4	+6	+8	V	

B) Driving for Backlight

Ta = 25 °C

Parameter	Min.	Typ.	Max.	Unit	Remark
Lamp voltage		225		Vrms	
Lamp current		3.5		mA	
Lamp frequency		35		KHz	

7-2) Power Consumption

Ta = 25 °C

Parameter	Conditions	TYP.	Unit	Remark
Current for V _{CC}	V _{CC} = +20V	2.3	mA	
Current for V _{BBA}	V _{BBA} = -5V	2.1	mA	
Current for V _{BBC}	V _{BBC} = -5V	0.05	mA	
Current for DV _{EE}	DV _{EE} = +14V	0.54	mA	
Current for AV _{EE}	AV _{EE} = +14V	3.0	mA	
Current for OV _{EE}	OV _{EE} = +14V	3.7	mA	
Current for V _{DD}	V _{DD} = +5V	5.7	mA	
LCD Panel Power Consumption		0.19	W	
Backlight Power Consumption		0.85	W	

7-3) Input / Output Timing

Parameter	Symbol	MIN.	TYP.	MAX.	Unit	Remarks
Horizontal Sync. Output Pulse	Width	T_{HO}	4.2	4.7	5.2	μs
	Phase Difference	T_{HP}	0	2		μs
	Rising Time	T_{HR}	-	-	0.5	μs
	Falling Time	T_{HF}	-	-	0.5	μs
Vertical Sync. Output Pulse	Width	T_{VO}	-	4H	-	μs H=1/15.75KHZ
	Phase Difference	T_{VPO}	-	1H	-	μs odd field
	Phase Difference	T_{VPE}	-	1.5H	-	μs even field
	Rising Time	T_{VR}	-	-	2	μs
	Frequency	f_{FRP}	7.67	7.87	8.07	KHZ
Polarity Alternating Signal	Delay time	T_{FD}	-	-	4	μs
	Falling Time	T_{VF}	-	-	2	μs

7-4) Display Time Range

A) When sync. signal of NTSC system is applied.

a) Horizontally

12.6 ~ 63.39 μs .

b) Vertical

19 ~ 253 H

B) When sync. signal of PAL system is applied.

a) Horizontally

13.0 ~ 63.8 μs .

b) Vertical

26 ~ 298 H

c) odd field : Scan lines 14n+17 14n+23 (n = 1, 2, 3..) are not displayed.

even field : Scan lines 14n+12 14n+20 (n = 1, 2, 3..) are not displayed.

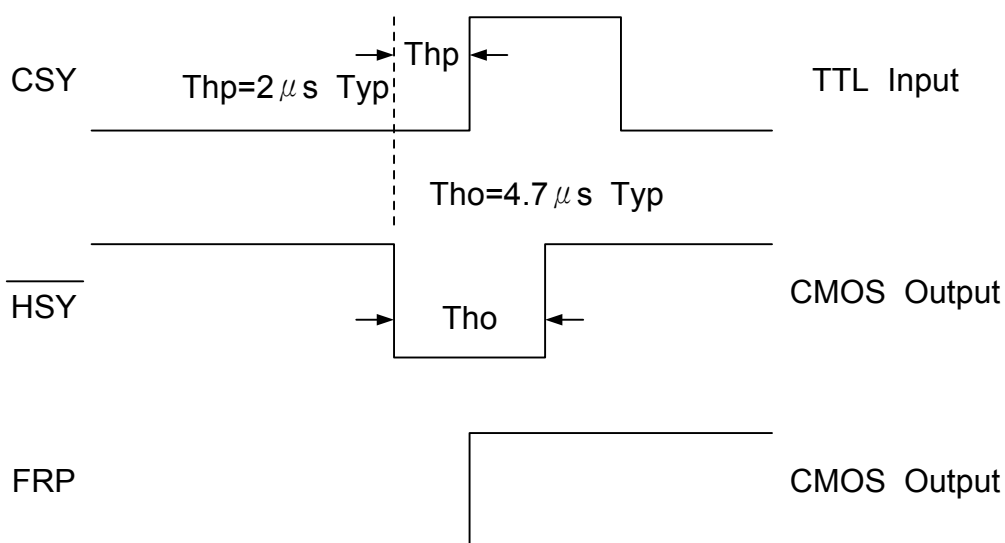

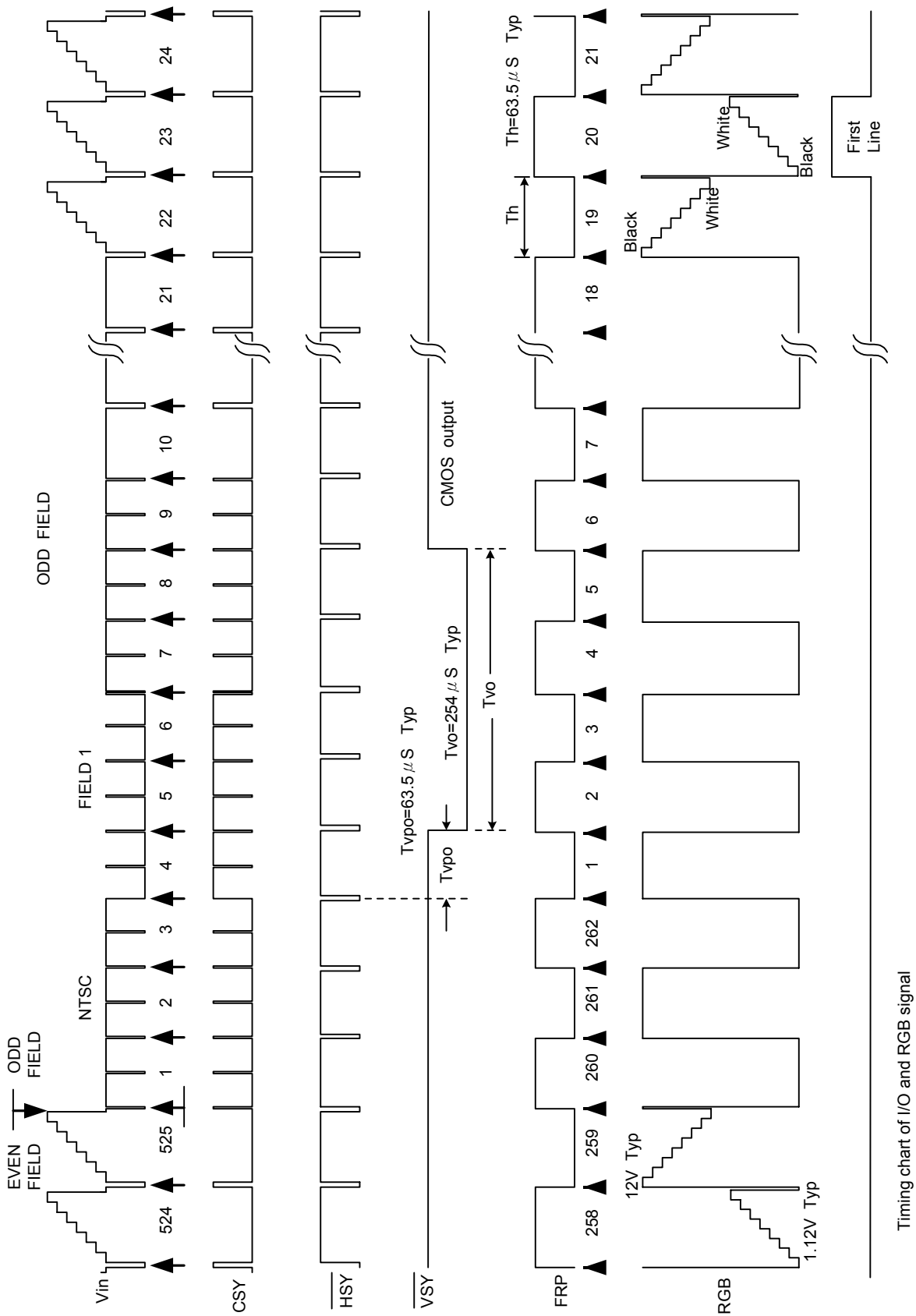

Timing chart of I/O and RGB signal

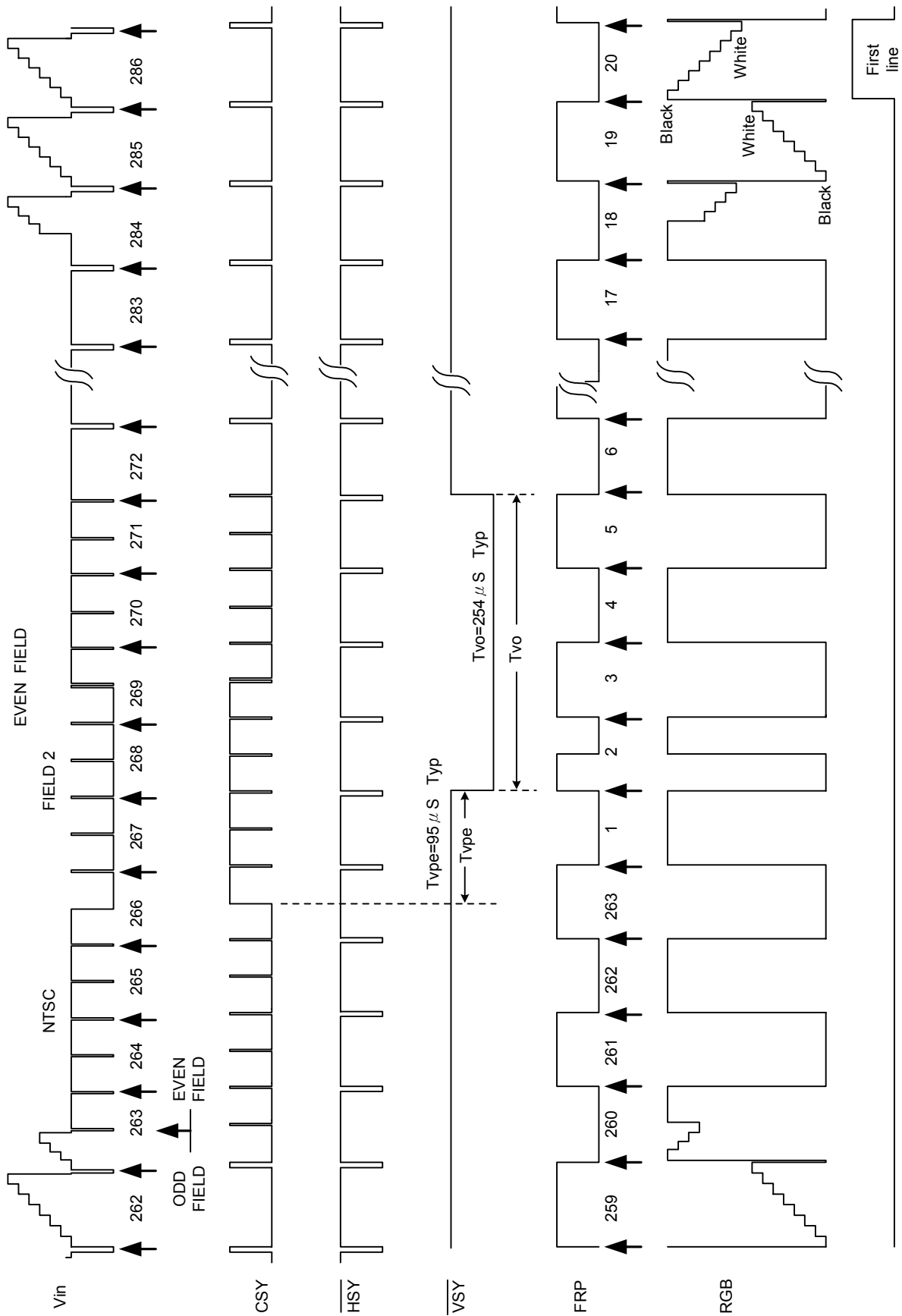

Timing chart of I/O and RGB signal

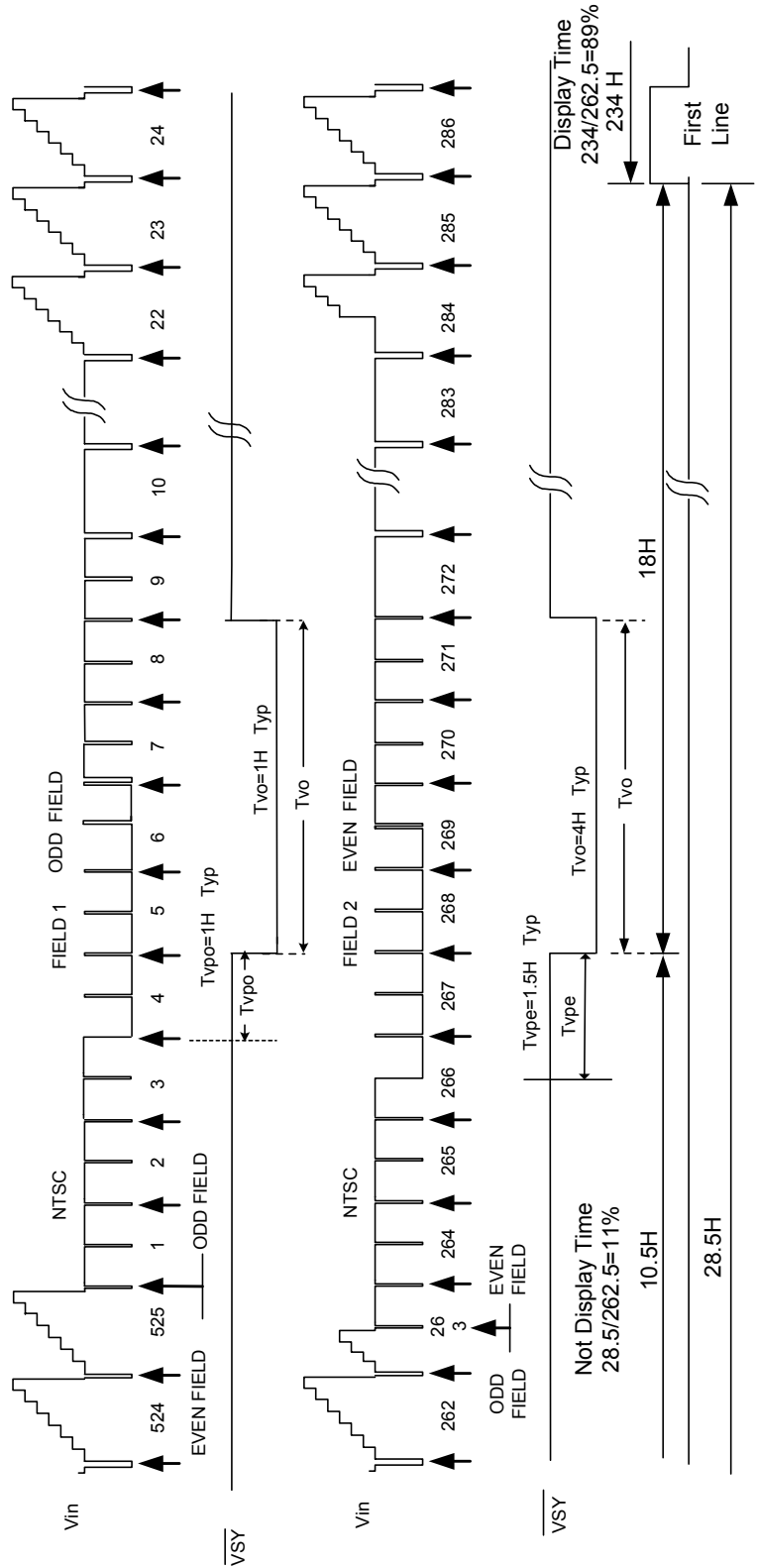
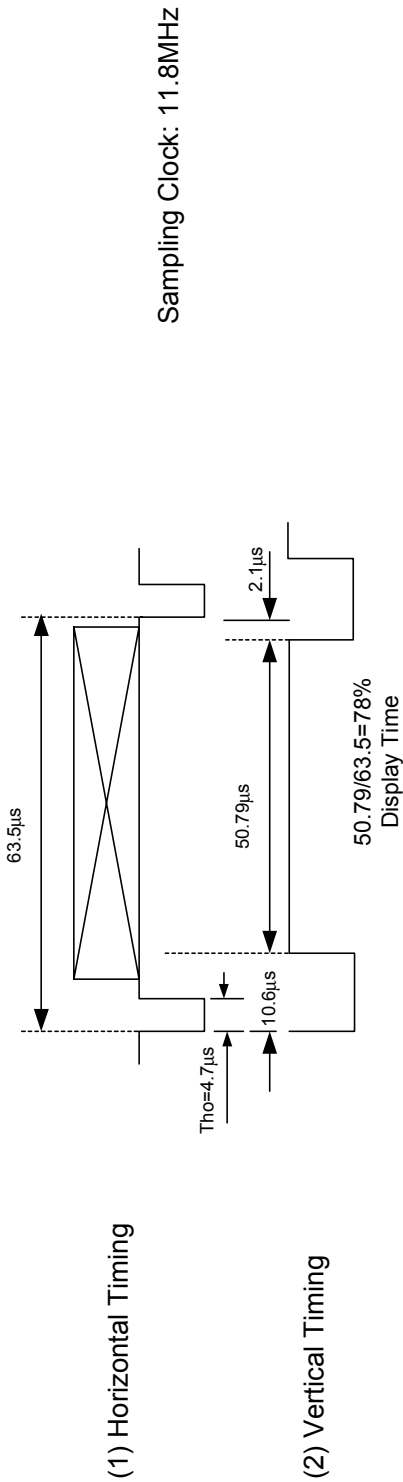

8. Optical Characteristics

Ta = 25°C

Parameter	Symbol	Condition	MIN.	TYP.	MAX.	Unit	Remarks
Viewing Angle	Horizontal	θ	CR > 10	± 45	± 55	deg	Note 8-2
	Vertical	θ (to 12 o'clock)		10	15	deg	
		θ (to 6 o'clock)		30	35	deg	
Contrast Ratio	CR		80	120			Note 8-1
Brightness	L	$\theta = 0^\circ$	250	280		nit	
Response time	Rise	Tr	$\theta = 0^\circ$			30	Note 8-3
	Fall	Tf	$\theta = 0^\circ$			50	
Color coordinate	White		$\theta = 0$	(.304, .333)			

Note 8-1 : $CR = \frac{\text{Luminance when testing point is White}}{\text{Luminance when testing point is Black}}$
 Contrast Ratio is measured in optimum common electrode voltage.
 Test configurations see section 8-2.

Note 8-2 : The definitions of viewing angles are as follows.

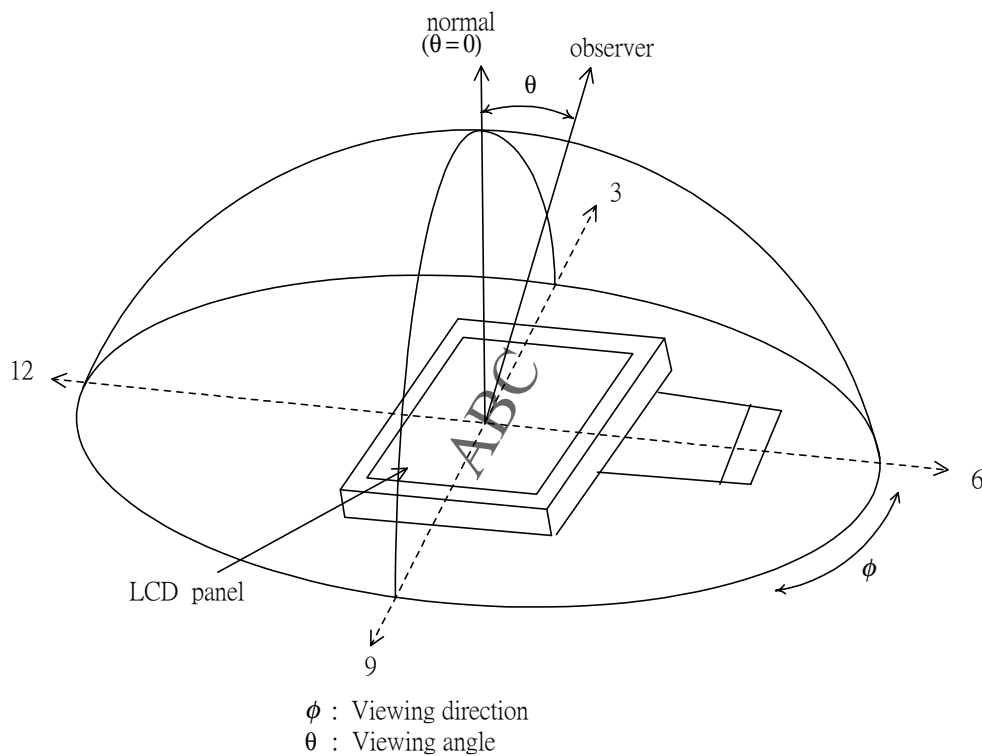

Note 8-3: The definitions of response time:

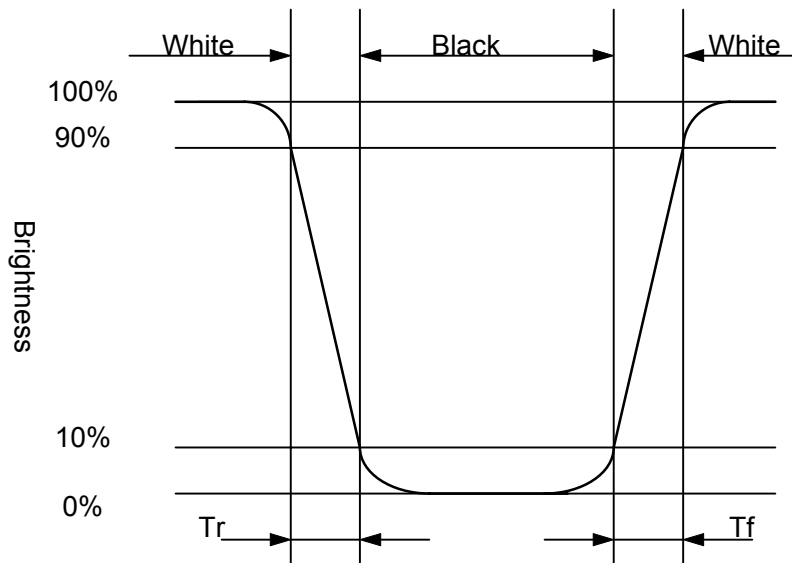

8-2) Test Configuration

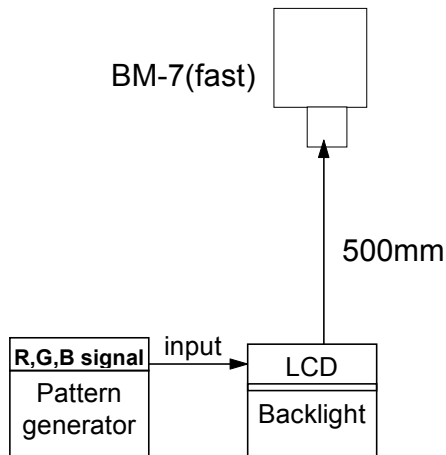

Caution: 1. Environmental illumination ≤ 1 lux
 2. Before test CR, Vcom voltage must be adjusted carefully to get the best CR.

- LCD Display
- Testing Point
- Testing Point

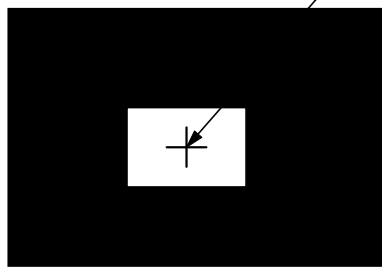

Pattern A

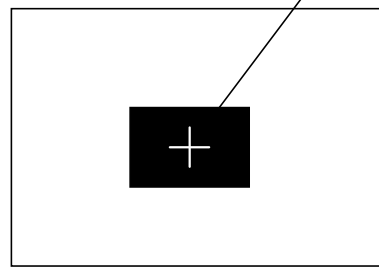

Pattern B

- R, G, B Waveform of Pattern A at Testing Point

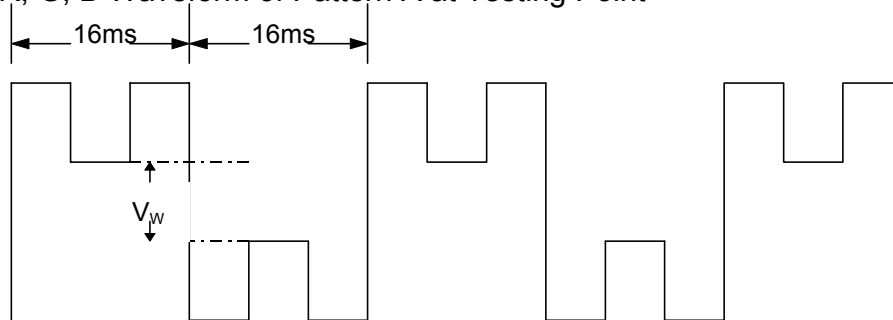

$V_w = 2.2V \pm 0.2V$

- G, B Waveform of Pattern B at Testing Point

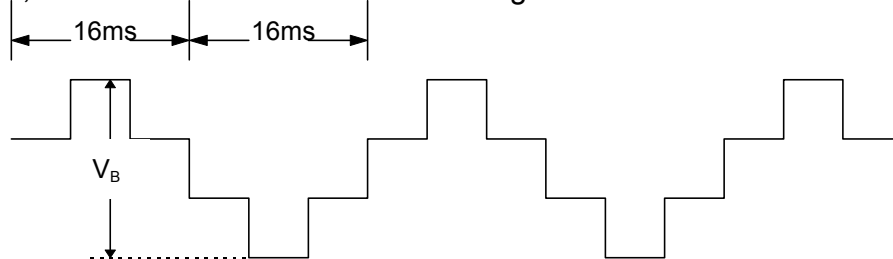

$V_b = 9.2V \pm 0.2V$

9. Reliability

No	Test Item	Test Condition
1	High Temperature Storage Test	Ta = +80 °C, 240 hrs
2	Low Temperature Storage Test	Ta = -20 °C, 240 hrs
3	High Temperature Operation Test	Ta= +60 °C, 240 hrs
4	Low Temperature Operation Test	Ta = -10 °C, 240 hrs
5	High Temperature & High Humidity Operation Test	Ta = +60 °C, 95%RH, 240 hrs
6	Thermal Cycling Test(non-operating)	-25 °C → +25 °C → +70 °C, 200 Cycles 30 min 5min 30 min
7	Electrostatic Discharge Test	150pF, 330 Ω 10 times/point, 4 points/panel face

Ta: ambient temperature

10. Block diagram:

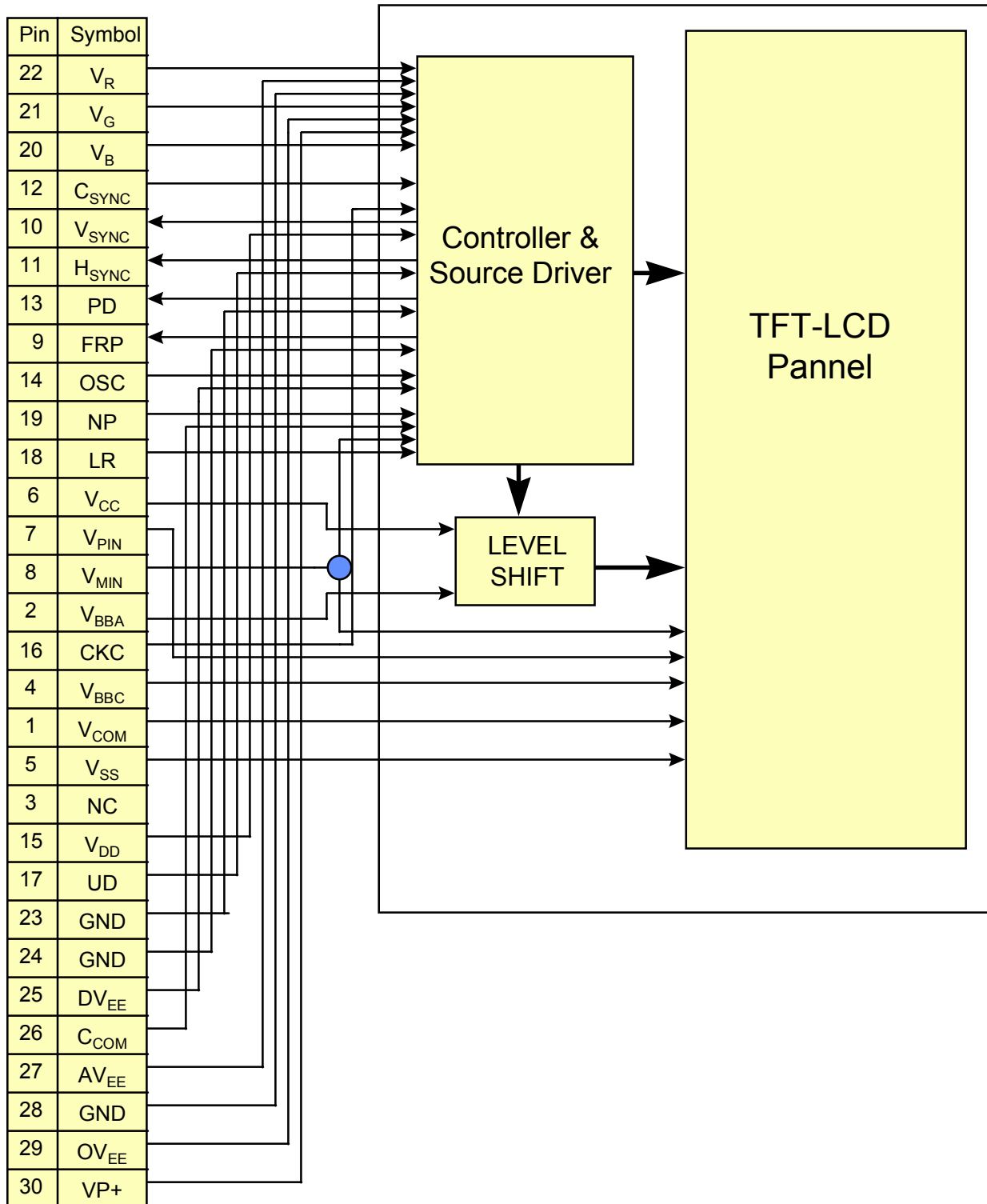

Revision History

Rev.	Issued Date	Revised Contents
P	Feb. 22, 1999	NEW
0.0	March, 03, 2000	Adding "Optical characteristics" : brightness spec. value Erase the appendix (some description about the interface board)