

P3710BT

N-Channel Enhancement Mode MOSFET

PRODUCT SUMMARY

$V_{(BR)DSS}$	$R_{DS(ON)}$	I_D
100V	37mΩ @ $V_{GS} = 10V$	31A

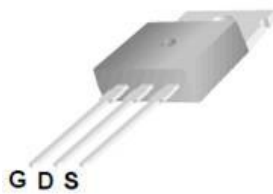

TO-220

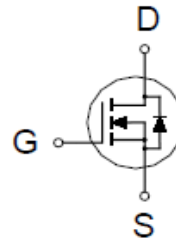

ABSOLUTE MAXIMUM RATINGS ($T_A = 25\text{ °C}$ Unless Otherwise Noted)

PARAMETERS/TEST CONDITIONS		SYMBOL	LIMITS	UNITS
Drain-Source Voltage		V_{DS}	100	V
Gate-Source Voltage		V_{GS}	±20	
Continuous Drain Current	$T_C = 25\text{ °C}$	I_D	31	A
	$T_C = 100\text{ °C}$		20	
Pulsed Drain Current ¹		I_{DM}	75	
Avalanche Current		I_{AS}	16	
Avalanche Energy ²		E_{AS}	128	mJ
Power Dissipation	$T_C = 25\text{ °C}$	P_D	78	W
	$T_C = 100\text{ °C}$		21	
Junction & Storage Temperature Range		T_J, T_{STG}	-55 to 150	°C

THERMAL RESISTANCE RATINGS

THERMAL RESISTANCE	SYMBOL	TYPICAL	MAXIMUM	UNITS
Junction-to-Case	$R_{\theta JC}$		1.6	°C / W

¹Pulse width limited by maximum junction temperature.

²Starting $T_j = 25\text{ °C}$, $L = 1\text{mH}$, $V_{DD} = 50\text{V}$

P3710BT

N-Channel Enhancement Mode MOSFET

ELECTRICAL CHARACTERISTICS (T_J = 25 °C, Unless Otherwise Noted)

PARAMETER	SYMBOL	TEST CONDITIONS	LIMITS			UNITS
			MIN	TYP	MAX	
STATIC						
Drain-Source Breakdown Voltage	V _{(BR)DSS}	V _{GS} = 0V, I _D = 250μA	100			V
Gate Threshold Voltage	V _{GS(th)}	V _{DS} = V _{GS} , I _D = 250μA	1	1.8	3	V
Gate-Body Leakage	I _{GSS}	V _{DS} = 0V, V _{GS} = ±20V			±100	nA
Zero Gate Voltage Drain Current	I _{DSS}	V _{DS} = 80V, V _{GS} = 0V			1	μA
		V _{DS} = 80V, V _{GS} = 0V, T _J = 125 °C			10	
Drain-Source On-State Resistance ¹	R _{DS(ON)}	V _{GS} = 4.5V, I _D = 10A		35	48	mΩ
		V _{GS} = 10V, I _D = 10A		27	37	
Forward Transconductance ¹	g _{fs}	V _{DS} = 10V, I _D = 10A		30		S
DYNAMIC						
Input Capacitance	C _{iss}	V _{GS} = 0V, V _{DS} = 25V, f = 1MHz		970		pF
Output Capacitance	C _{oss}			129		
Reverse Transfer Capacitance	C _{rss}			59		
Total Gate Charge ²	Q _g	V _{DS} = 50V, I _D = 10A, V _{GS} = 10V		25		nC
Gate-Source Charge ²	Q _{gs}			4.3		
Gate-Drain Charge ²	Q _{gd}			8.3		
Turn-On Delay Time ²	t _{d(on)}	V _{DD} = 50V I _D ≅ 10A, V _{GS} = 10V, R _{GS} = 6Ω		30		nS
Rise Time ²	t _r			21		
Turn-Off Delay Time ²	t _{d(off)}			45		
Fall Time ²	t _f			21		
SOURCE-DRAIN DIODE RATINGS AND CHARACTERISTICS (T_J = 25 °C)						
Continuous Current	I _S				31	A
Forward Voltage ¹	V _{SD}	I _F = 10A, V _{GS} = 0V			1.2	V
Reverse Recovery Time	t _{rr}	I _F = 10A, dI _F /dt = 100A / μS		36		nS
Reverse Recovery Charge	Q _{rr}				52	

¹Pulse test : Pulse Width ≤ 300 μsec, Duty Cycle ≤ 2%.

²Independent of operating temperature.

P3710BT

N-Channel Enhancement Mode MOSFET

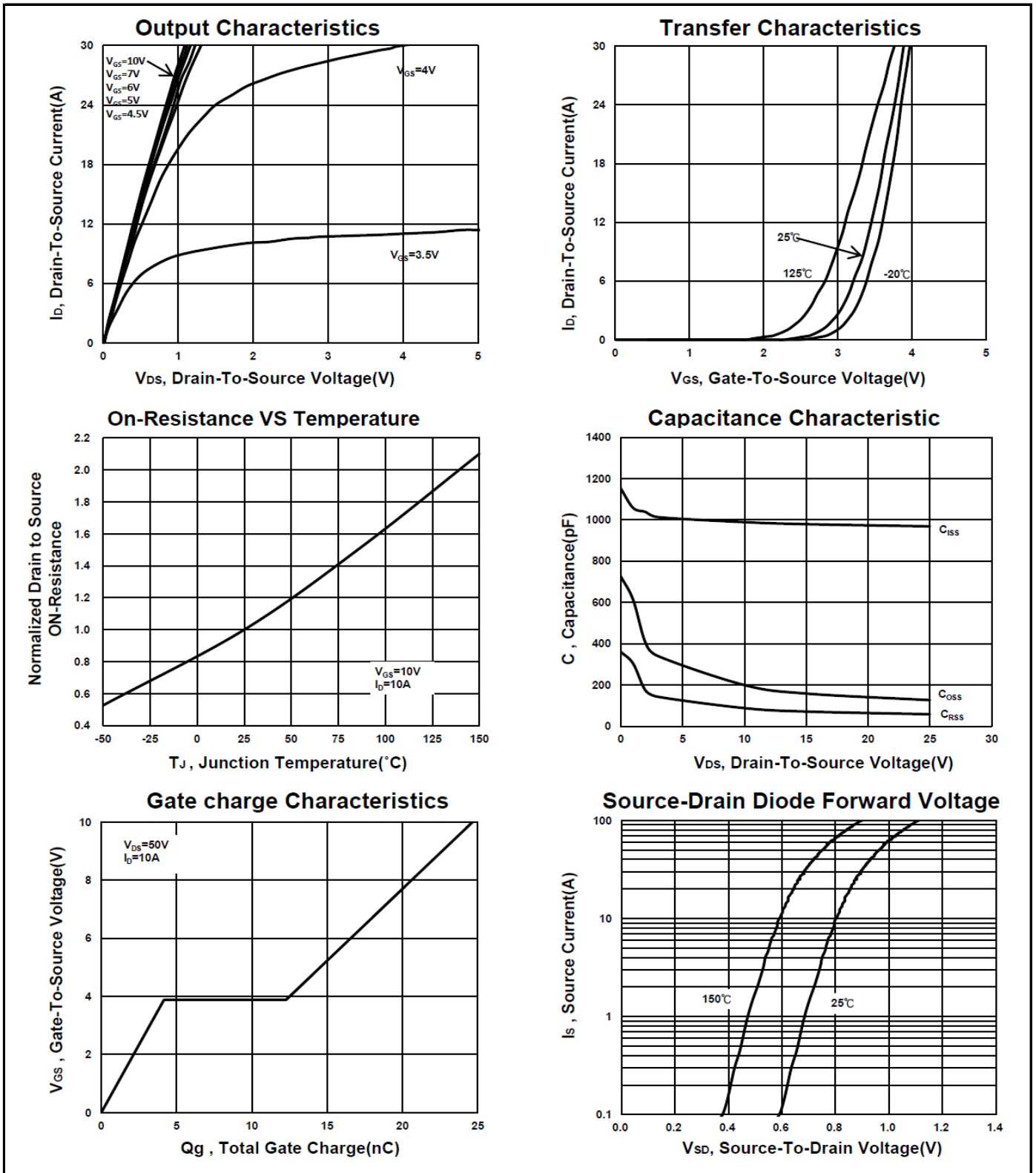

P3710BT

N-Channel Enhancement Mode MOSFET

Safe Operating Area

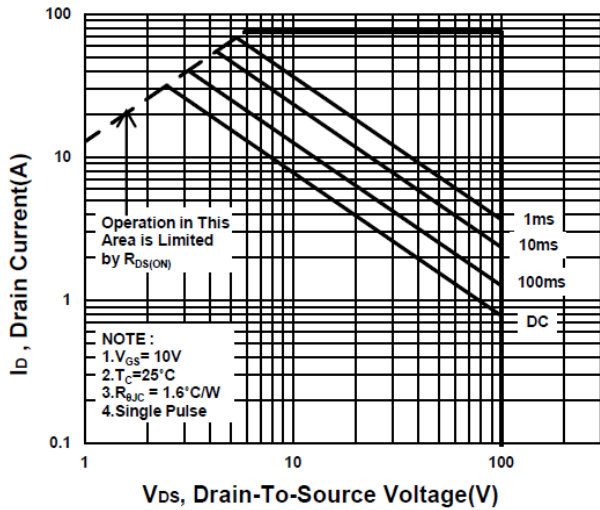

Single Pulse Maximum Power Dissipation

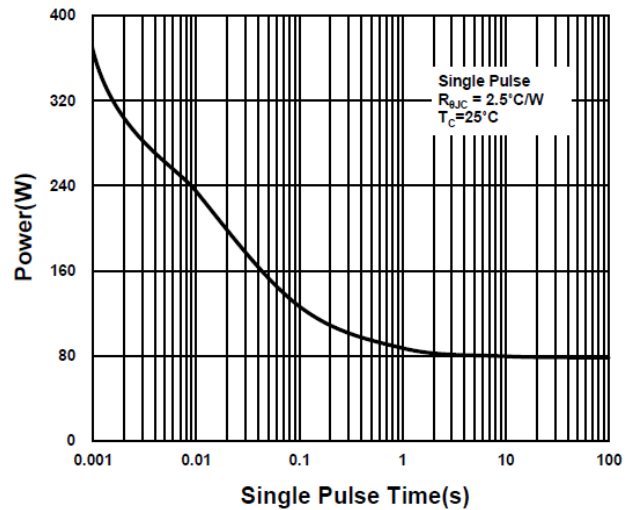

Transient Thermal Response Curve

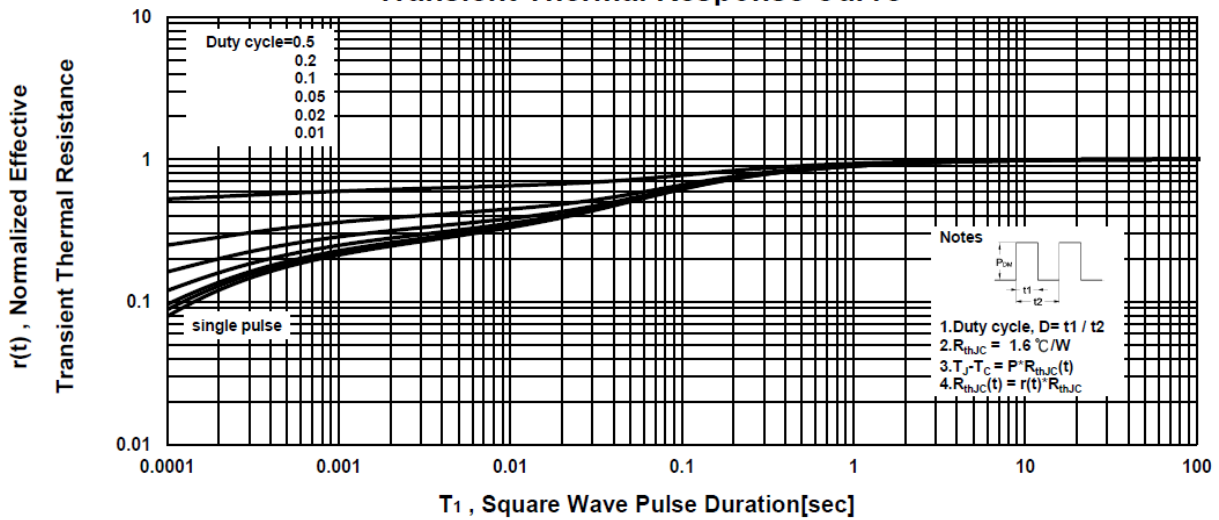

P3710BT

N-Channel Enhancement Mode MOSFET

Package Dimension

TO-220 (3-Lead) MECHANICAL DATA

Dimension	mm			Dimension	mm		
	Min.	Typ.	Max.		Min.	Typ.	Max.
A	9.65		11.5	J	3.55		4.83
B		2.54		K	1.11		1.45
C	18.1		22.86	L	1.89		3.09
D	26.9		31.24	M	0.34		0.61
E	14.32		16.51	N	2.6		4.06
F	8.38		9.3	O		3.7	
G	0.38		1.02	P	5.84		6.85
H	2.04	2.54	3.04	Q	12.5		14.73
I	1.14		1.8	R	11.3		13.31

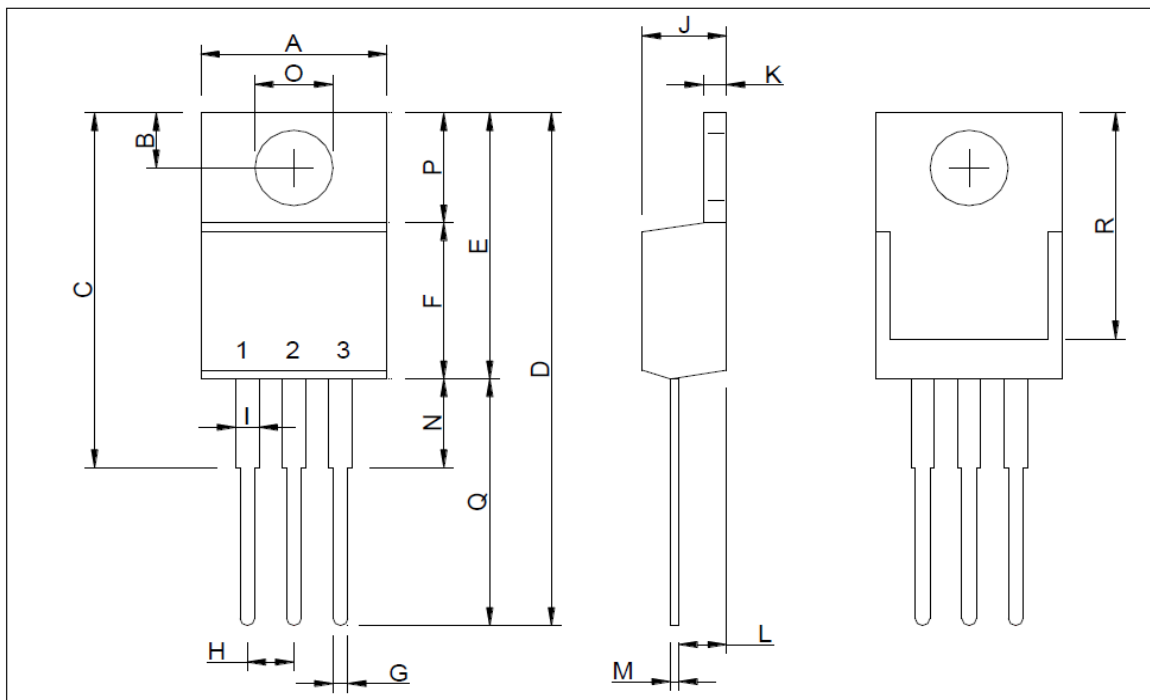

P3710BT

N-Channel Enhancement Mode MOSFET

A. Marking Information

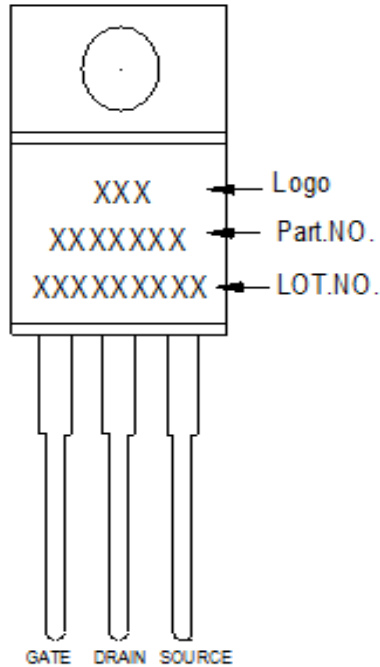

B. Tape&Reel Information:50pcs/Tube

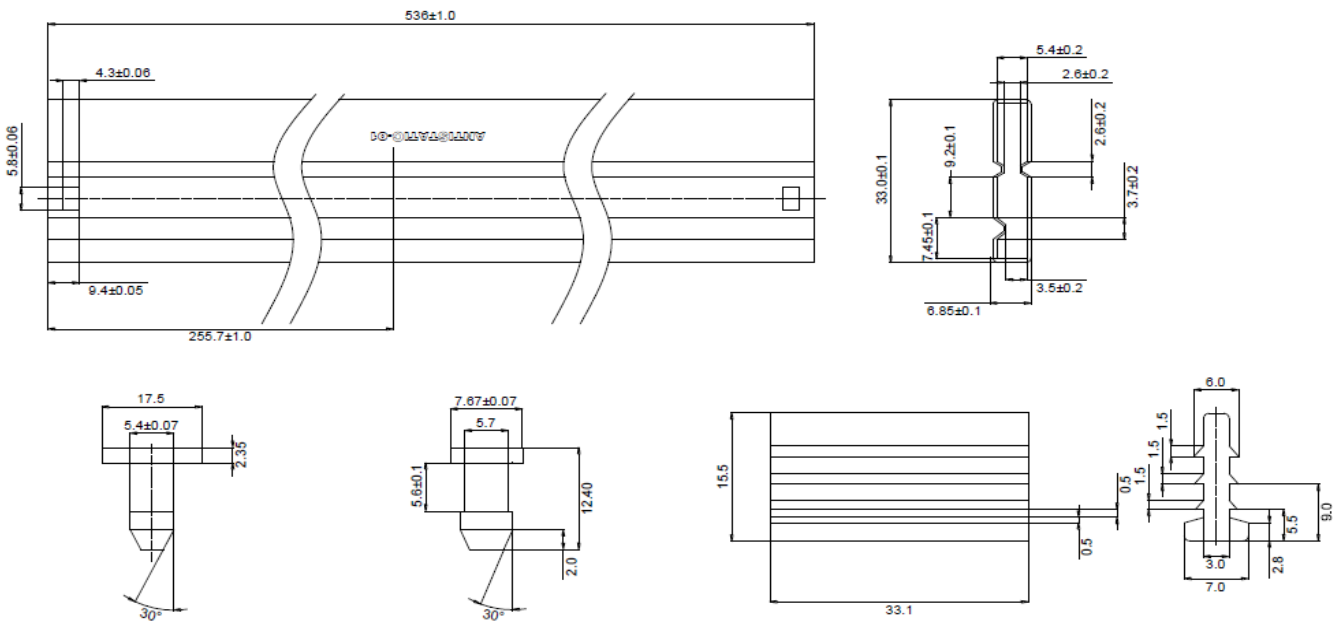

P3710BT

N-Channel Enhancement Mode MOSFET

C. Lot No.&Date Code rule

1.Lot No.

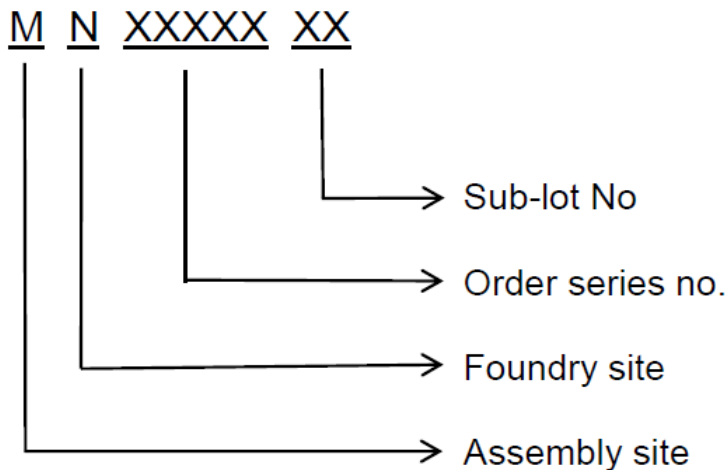

2.Date Code

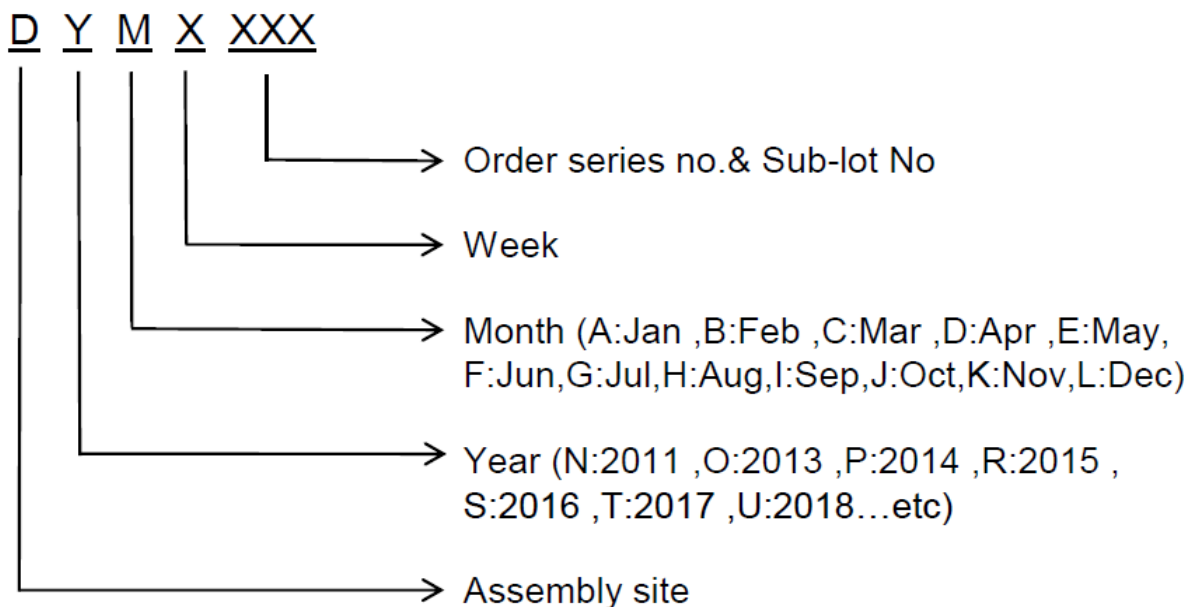



P3710BT

N-Channel Enhancement Mode MOSFET

D.Label rule

标签内容(Label content)



1	Label Size	30 * 90 mm
2	Font style	Times New Roman or Arial (或可区分英文”0”和数字”0”，”G和”Q”的字型即可)
3	U-NIKC	Height: 4 mm
4	Package	Height: 2 mm
5	Date	Height: 2 mm Shipping date: YYYY/MM/DD, ex. 2008/09/12
6	Device	Height: 3 mm (Max: 16 Digit)
7	Lot	Height: 3 mm (Max: 9 Digit) Sub lot
8	D/C	Height: 3 mm (Max: 7 Digit)
9	QTY	Height: 3 mm (Max: 6 Digit) Thousand mark is no needed
10	RoHS label	 long axis: 12 mm minor axis: 6 mm bottom color: White Font color: Black Font style: Arial
11	Halogen Free label	 Diameter: 10 mm bottom color: Green Font color: Black Font style: Arial
12	Scan information	Device / Lot / D/C / QTY , Insert “ / “ between every parts. for example: P3055LDG/G12345601/GGG2301/2000 DPI (Dots per inch): Over 300 dpi Code : Code 128 Height: 6 mm at least