

# **Service Manual**

**Model: P42L6A-T1**

**Specifications & Design are subject to change without notice.**

## Contents

|  |           |
|--|-----------|
| 1. Contents.....                           | 1         |
| 2. Features.....                           | 2         |
| 3. Safety Precautions.....                 | 3         |
| 4. Photo of PDP taking apart.....          | 6         |
| 5. PANEL Part.....                         | 8         |
| a. Adjustment.....                         | 8         |
| b. Trouble Shooting.....                   | 10        |
| c. Power specification.....                | 20        |
| 6. Introduction to PDP circuit boards..... | 23        |
| a: Signal flow-chart.....                  | <b>23</b> |
| <b>b: CHIP SUMMARY.....</b>                | <b>24</b> |
| <b>c: Debug flow-chart.....</b>            | <b>25</b> |
| 7. Circuit Drawing.....                    | 26        |

## 1. Features

The 42" PDP provides quality image displays and is suitable for a variety of multimedia applications.

### a. Available Input signals:

- The Digital module provides RGB (D-SUB15 PIN) and digital DVI input connectors, and component video (RCA) input connectors. It supports the quality input image of DVD and HDTV (480P/720P/1080i/1080P).
- The analogue module provides composite video (RCA), S-video (DIN4P), The analogue module also provides one set of stereo audio input connectors (RCA).
- The product supports PC image resolutions up to XGA (1024 768) with a vertical frequency of 75HZ.
- RF terminal,you can watch TV expediently,The format contain PAL-M/N,NTSC-M

### b. General specification

- Model name: P42L6A-T1(H)
- Number of pixel:1024(H) × 768(V) (1Pixel=3RGB Cells)
- Display area : 920.1(H) x 518.4(V) ± 0.5mm
- Color arrangement : RGB Closed type
- Number of COLRO : (R)1024 x (G)1024 x (B)1024
- Aspect Ratio : 16:9
- Peak Brightness : Typical 1200dc/ (1/100 White Window)
- Contrast Ratio : Typical 10000:1(Dark room 1/100 White Window) (White Window Pattern at Center)
- POWER CONSUMPTION : Typical 320 W(Full White)
- Available voltage range:AC110V~240V
- Frequency range:50~60HZ( ± 3HZ)

## 2. Safety Precautions

When servicing of PDP Module, it should be not enforced into another way aside next rule, or a unaccustomed person should not repairing. When using/handling this PDP Module, pay attention to the below warning and cautions.

### **Warning**

Indicates a hazard that may lead to death or injury if the warning is ignored and the product is handled incorrectly.

### **Caution**

Indicates a hazard that can lead to injury or damage to property if the caution is ignored and the product is handled incorrectly.

#### **1) WARNING**

(1) Do not touch Signal and Power Connector while this product operates.

Do not touch EMI ground part and Heat Sink of Film Filter.

(2) Do not supply a voltage higher than that specified to this product. This may damage the product and may cause a fire.

(3) Do not use this product in locations where the humidity is extremely high, where it may be splashed with water, or where flammable materials surround it.

Do not install or use the product in a location that does not satisfy the specified environmental conditions. This may damage the product and may cause a fire.

(4) If a foreign substance (such as water, metal, or liquid) gets inside the product, immediately turn off the power.

Continuing to use the product, it may cause fire or electric shock.

(5) If the product emits smoke, and abnormal smell, or makes an abnormal sound, immediately turn off the power.

Continuing to use the product, it may cause fire or electric shock.

(6) Do not disconnect or connect the connector while power to the product is on. It takes some time for the voltage to drop to a sufficiently low level after the power has been turned off.

Confirm that the voltage has dropped to a safe level before disconnecting or connecting the connector.

(7) Do not pull out or insert the power cable from/to an outlet with wet hands. It may cause electric shock.

(8) Do not damage or modify the power cable. It may cause fire or electric shock.

(9) If the power cable is damaged, or if the connector is loose, do not use the product: otherwise, this can lead to fire or electric shock.

(10) If the power connector or the connector of the power cable becomes dirty or dusty, wipe it with a dry cloth. Otherwise, this can lead to fire.

(11) PDP Module uses a high voltage (Max.450V dc). Keep the cautions concerning electric shock and do not touch the Device circuitry when handling the PDP Unit. And because the capacitor of the Device circuitry may remain

charged at the moment of Power OFF, standing by for 1 minute is required in order to touch the Device circuitry.

## **2) CAUTIONS**

(1) Do not place this product in a location that is subject to heavy vibration, or on an unstable surface such as an inclined surface. The product may fall off or fall over causing injuries.

(2) Before disconnecting cable from the product, be sure to turn off the power. Be sure to hold the connector when disconnecting cables. Pulling a cable with excessive force may cause the core of the cable to be exposed or break the cable, and this can lead to fire or electric shock.

(3) This product should be moved by two or more persons. If one person attempts to carry this product alone, he/she may be injured.

(4) This product contains glass. The glass may break, causing injuries, if shock, vibration, heat, or distortion is applied to the product.

(5) The temperature of the glass of the display may rise to 80°C or more depending on the conditions of use. If you touch the glass inadvertently, you may be burned.

(6) If glass surface of the display breaks or is scratched, do not touch the broken pieces or the scratches with bare hands. You may be injured.

(7) PDP Module requires to be handled with care not to be touched with metal or hard materials, and must not be stressed by heat or mechanical impact.

(8) There are some exposed components on the rear panel of this product. Touching these components may cause an electric shock.

(9) When moving the product, be sure to turn off the power and disconnect all the cables. While moving the product, watch your step. The product may be dropped or all leading to injuries of electric shock.

(10) In order to protect static electricity due to C-MOS circuitry of the Drive part, wear a wrist band to protect static electricity when handling.

(11) If cleaning the Panel, wipe it with a soft cloth moistened with water or a neutral detergent and squeezed, being careful not to touch the connector part of the Panel. And don't use chemical materials like thinner or benzene.

(12) If this product is used as a display board to display a static image, "image sticking" occurs. This means that the luminance of areas of the display that remain lit for a long time drops compared with luminance of areas that are lit for a shorter time, causing uneven luminance across the display. The degree to which this occurs is in proportion to the luminance at which the display is used. To prevent this phenomenon, therefore, avoid static images as much as possible and design your system so that it is used at a low luminance, by reducing signal level difference between bright area and less bright area through signal processing.

(13) Because PDP Module emits heat from the Glass Panel part and the Drive circuitry, the environmental temperature must not be over 40°C.

The temperature of the Glass Panel part is especially high owing to heat from

internal Drive circuitry. And because the PDP Module is driven by high voltage, it must avoid conductive materials.

(14) If inserting components or circuit board in order to repair, be sure to fix a lead line to the connector before soldering.

(15) If inserting high-power resistor (metal-oxide film resistor or metal film resistor) in order to repair, insert it as 10mm away as from a board.

(16) During repairs, high voltage or high temperature components must be put away from a lead line.

(17) This is a Cold Chassis but you had better use a cold transformer for safety during repairs. If repairing electricity source part, you must use the cold transformer.

(18) Do not place an object on the glass surface of the display. The glass may break or be scratched.

(19) This product may be damaged if it is subject to excessive stresses (such as excessive voltage, current, or temperature).

The absolute maximum ratings specify the limits of these stresses.

(20) The recommended operating conditions are conditions in which the normal operation of this product is guaranteed. All the rated values of the electrical specifications are guaranteed within these conditions.

Always use the product within the range of the recommended operating conditions. Otherwise, the reliability of the product may be degraded.

(21) This product has a glass display surface. Design your system so that excessive shock and load are not applied to the glass. Exercise care that the vent at the corner of the glass panel is not damaged. If the glass panel or vent is damaged, the product is inoperable.

(22) Do not cover or wrap the product with a cloth or other covering while power is supplied to the product.

(23) Before turning on power to the product, check the wiring of the product and confirm that the supply voltage is within the rated voltage range. If the wiring is wrong or if a voltage outside the rated range is applied, the product may malfunction or be damaged.

(24) Do not store this product in a location where temperature and humidity are high. This may cause the product to malfunction. Because this product uses a discharge phenomenon, it may take time to light (operation may be delayed) when the product is used after it has been stored for a long time. In this case, it is recommended to light all cells for about 2 hours (aging).

(25) This product is made from various materials such as glass metal, and plastic. When discarding it, be sure to contact a professional waste disposal operator.

(26) If faults occur due to arbitrary modification or disassembly, HAIER is not responsible for function, quality or other items.

(27) Use of the product with a combination of parameters conditions or logic not specified in the specifications of this product is not guaranteed. If intending to use the product in such a way, be sure to consult HAIER in advance.

### 3.Photo of PDP taking apart

#### The introduction of circuit board at Back board:

| NAME             | MATERIAL CODE |
|------------------|---------------|
| MODEL (PDP 42X3) | 0094014444    |
| X-SUS(left)      | 0094014670    |
| X-SUS(right)     | 0094014671    |
| Y-SUS            | 0094014672    |
| Y-DRIVER         | 0094014673    |
| Z-SUS            | 0094014674    |
| CTROL BOARD      | 0094014675    |
| PSU              | 0094014676    |

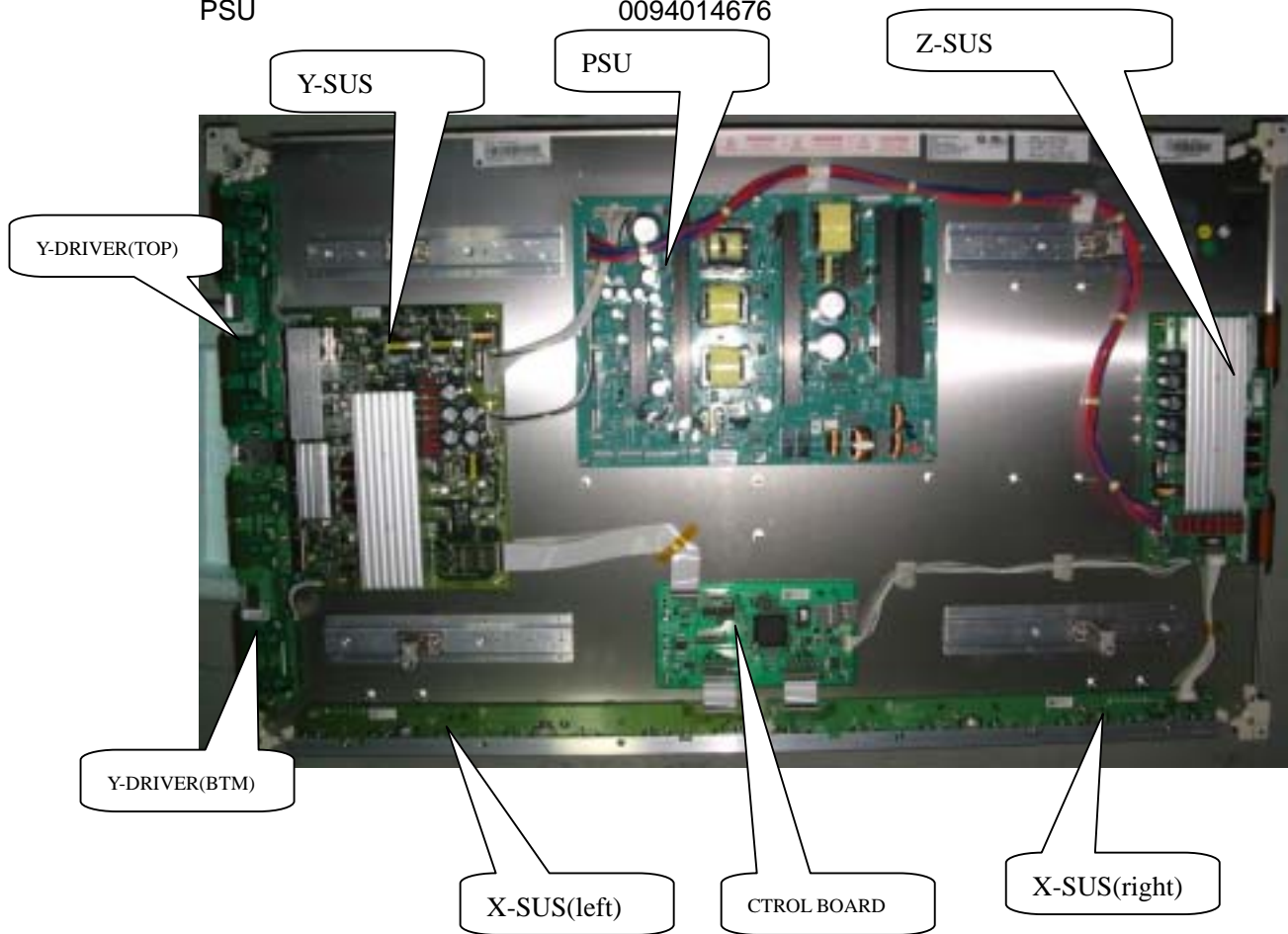

**Printed Circuit Digital Board(Main Board)In bom we call it Digital board subassembly**



**Printed Circuit Audio Board , In bom we call it Emulation board subassembly**

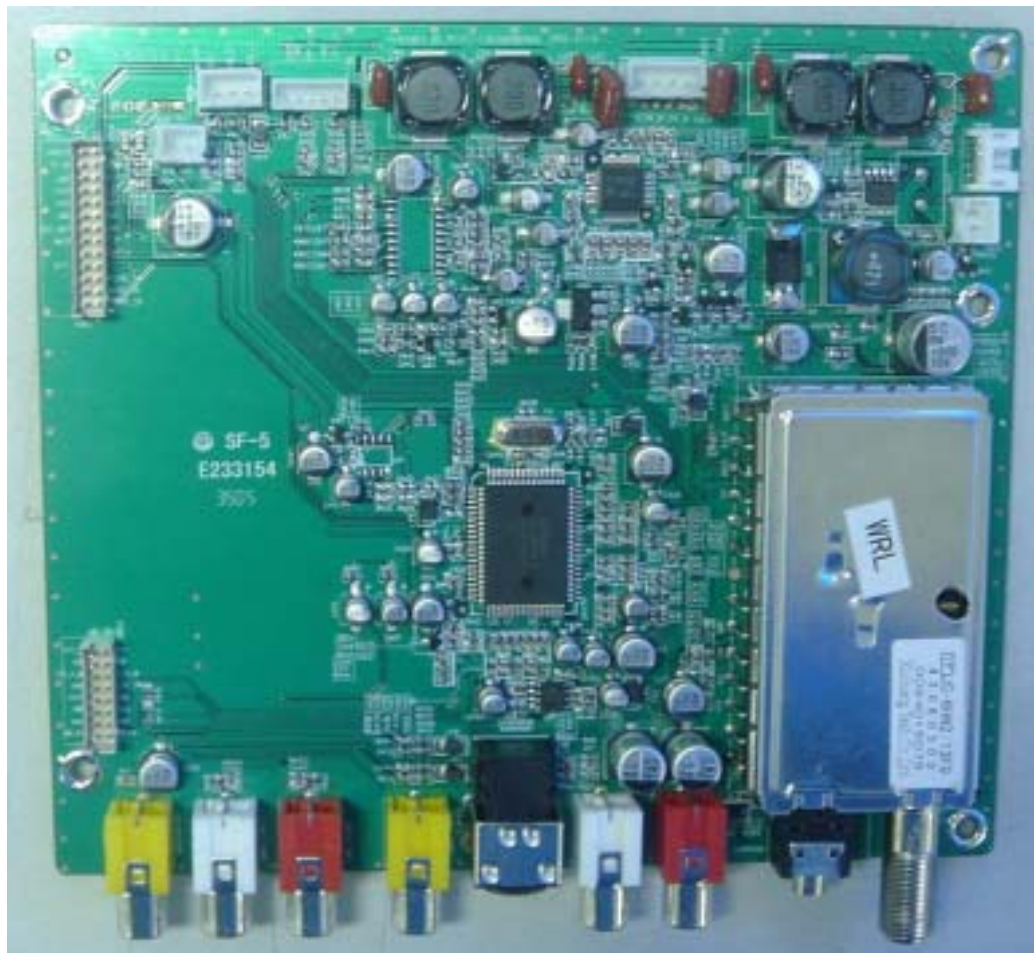



## 4. Panel part

### a. Adjustment

#### 1. Application Object

This standard is applied to the PDP42V7#### PDP Module which is manufactured by the manufacturing team of PDP promotion department or elsewhere.

#### 2. Notes

- (1) Without any special specification, the Module should be at the condition of preliminaries more than 10minutes before adjusting.
  - Service signal : 100% Full White signal
  - Service DC voltage : Vcc: 5V, Va: 65V, Vs: 187V
  - DC/DC Pack voltage : Vsc=115V  
-Vy: -85V
  - Preliminaries environment : Temp (25±5°C), Relative humidity (65±10%)
- (2) Module should get the Aging for the equilibrium after finish the assembling. Aging condition is shown below.
  - Service signal: 100% Full White, Red, Green, Blue pattern signal(Service time of each pattern : within 5minutes/cycle)
  - Service DC voltage : Match the voltage with the set up voltage in the first adjustment.
  - Aging time : More than 30 minutes
  - Aging environment : Temp (25±2°C), Relative humidity- Less than 65%
- (3) Module adjustment should be followed by below sequence.
  - Setting up the Vsc/-Vy voltage(Vsc=115V, -Vy=-85V)
  - Adjusting the voltage wave form(Refer to adjustment)
  - 25±5°C, 65±10%
- (4) Without any special specification, you should adjust the Module in the environment of Temp (25±5°C) and Relative humidity (65±10%)

**Caution)** If you let the still image more than 10 minutes(especially The Digital pattern or Cross Hatch Pattern which has clear gradation), after image can be presented in the black level part of screen.

### 3. Adjustment after Assembling

#### 3-1. Using Tools

- (1) Digital oscilloscope : More than 200MHz
- (2) DVM(Digital Multimeter) : Fluke 87 or similar one
- (3) Signal generator : VG-825 or similar one
- (4) DC power supply or PSU
  - DC power supply for Vs (1) : Should be changeable between 0V to 200V/ more than 10A
  - DC power supply for Va (1) : Should be changeable between 0V to 100V/ more than 5A
  - DC power supply for 5V (1) :Should be changeable between 0V to 10V/ more than 10A
  - DC-DC Converter Jig (1) : The Jig which has equivalent voltage output of PDP42V7#### Module after taking the Vs, Va, 5V voltage
  - Voltage stability of power supply : Within ±1% for Vs/Va, within ±3% for 5V

#### 3-2. Connection diagram of measuring instrument and setting up the initial voltage

- (1) For connection diagram of measuring instrument, refer to Fig. 1.(Connection diagram of measuring instrument that adjusting the voltage wave form)
- (2) Setting up the initial voltage(Voltage Label)  
Vcc: 5V, Va: 65V, Vs: 187V  
But, Initially setting up voltage can be changed by the set up range according to the Module's characteristic.

#### 3-3. How to Adjust

##### (1) Adjusting Vset-up Voltage Wave form

- ① Connect the measuring instrument to be (Fig. 1).
- ② Turn on the measuring instrument with Caution of (Fig. 1).
- ③ Connect the oscilloscope probe to B39(Bead) of Y B/D bottom and GND.
- ④ Turn the VR1 of Y B/D and make the "A" waveform Fig. 2 to be 10±2μs.

##### (2) Adjusting Vset-down Voltage Wave form

- ① Turn the VR2 of Y SUS B/D and make the "B" waveform Fig. 2 to be 100±2μs.

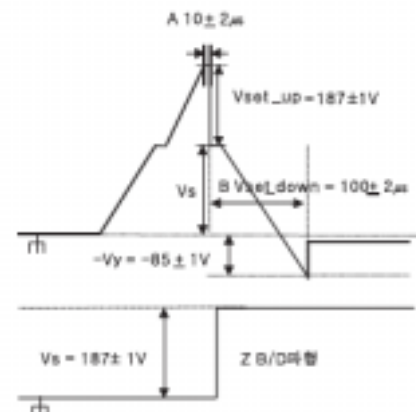

(Fig. 2) Y, Z set-up Waveform

##### (3) Checking the DC/DC pack voltage

- ① Convert the signal of signal generator to the 100% Full White signal.
- ② Connect the GND terminal of DVM to the right leg of R53 on the Y B/D and set the Plus terminal to the left leg of R53 to check the Vsc voltage(115±1V) and when there is abnormality in voltage turn the variable resistor(VR3) of DC/DC Pack(Vsc) PS1 on Y B/D to adjust.
- ③ Connect the GND terminal of DVM to the right leg of R78 on the Y B/D and set the Plus terminal to the left leg of R78 to check the -Vy voltage(-85±1V) and when there is abnormality in voltage turn the variable resistor(VR4) of DC/DC Pack(-Vy) PS1 on Y B/D to adjust.

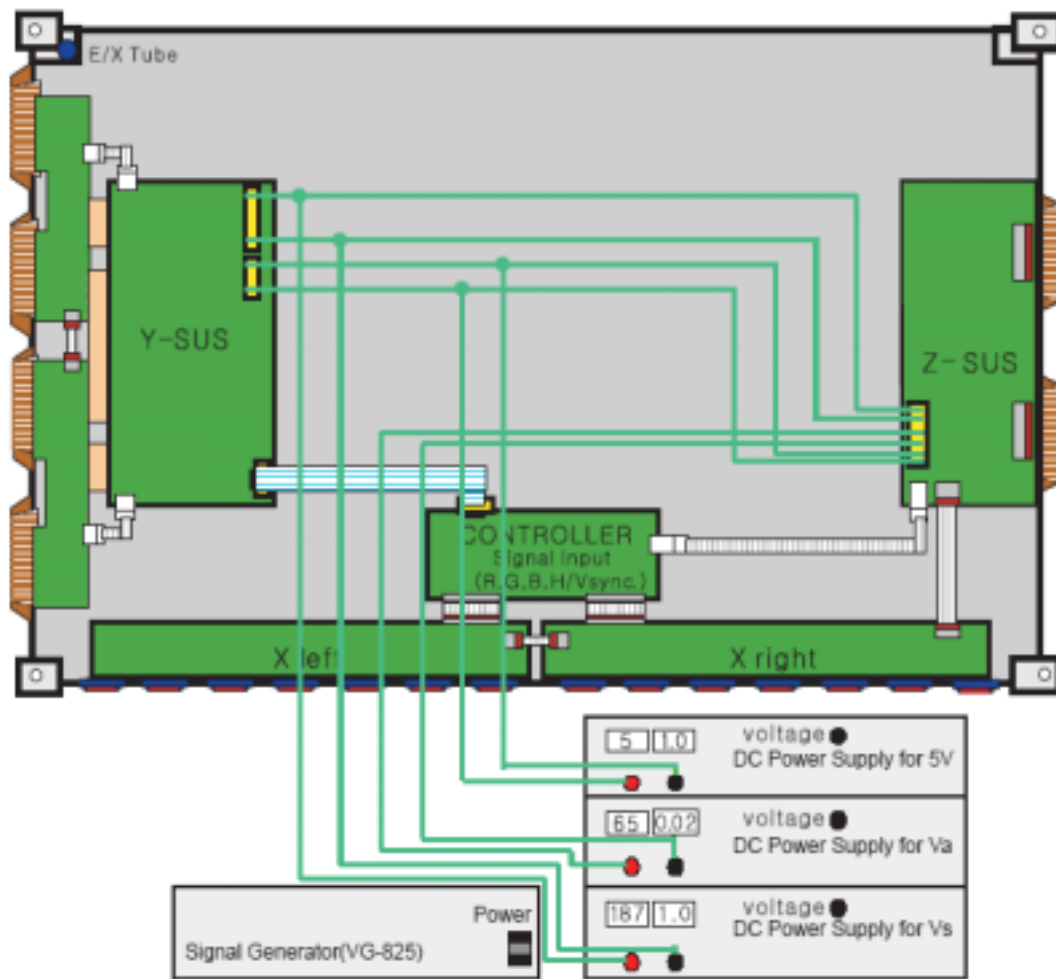

**<Caution>**

- (1) The power of the signal generator should be turned on before turning on the power of DC power supply.
- (2) The voltage of DC power supply , in standard of Module input voltage, should be preset as below.  
Vcc: 5V, Va: 65V, Vs: 187V
- (3) The power of power supply must turned on by this sequence. Reverse direction When turning off.  
\* Module on : 5V  $\Rightarrow$  Va  $\Rightarrow$  Vs, Module off: Vs  $\Rightarrow$  Va  $\Rightarrow$  5V
- (4) Signal generator should be selected with 852-480(WVGA) mode.

※ Also the PSU(Power Supply Unit) use is possible

(Fig. 1) Connection diagram of measuring instrument

## b. Trouble shooting

### 1. Checking for no Picture

A screen doesn't display at all and condition of black pattern or power off.

- (1) Check whether the CTRL B/D LED(D1, D2, D3, D4, D5) is turned on or not.
- (2) Check the power and signal cable of CTRL B/D.
- (3) X B/D, Y B/D, Z B/D is well plugged in.
- (4) Check the connection of X B/D, Y B/D and Z B/D to CTRL B/D.
- (5) Measure the output wave of X, Y, Z B/D with oscilloscope(more than 200MHz) and find the trouble of B/D by comparing the output wave with below figure.
  - Measure Point fo Y B/D : Bead B39
  - Measure Point fo Z B/D : Bead B28
  - Measure Point fo X B/D : P3
- (6) Check the SCAN(Y side) IC
- (7) Check the DATA(X side) TCP IC
- (8) Replace the CTRL B/D.
- (9) Check the Fuse of Y, Z B/D is open and replace when open.
- (10) Check the input voltage. ( $V_{cc}=5V/V_a=65V/V_s=187V$ )

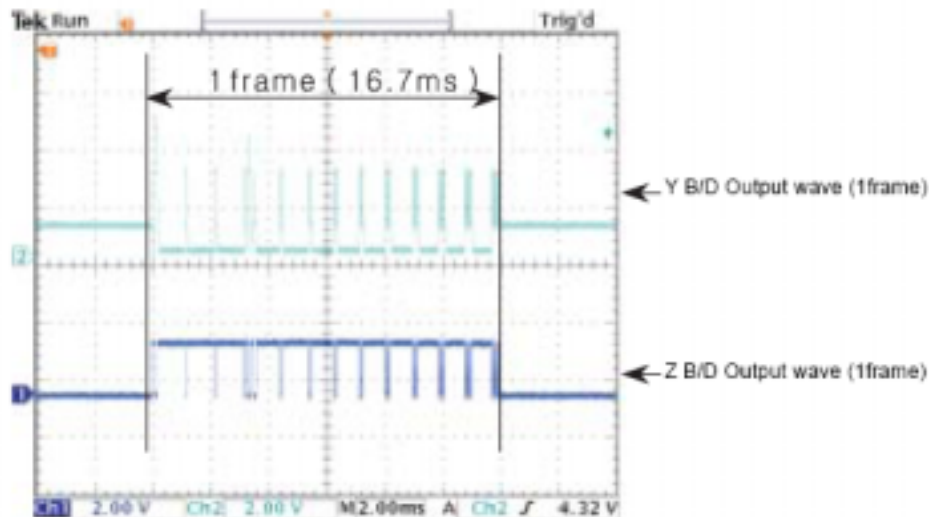

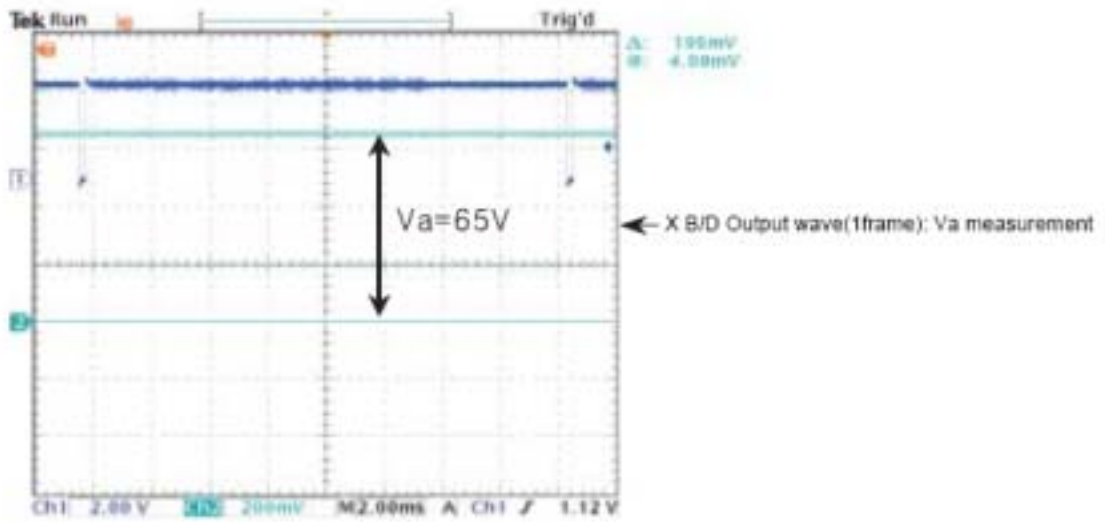
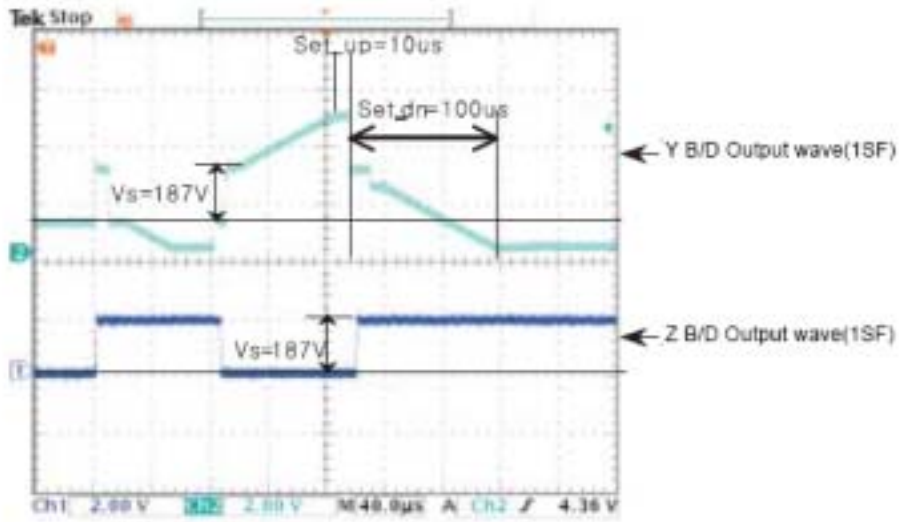

## 2. Hitch Diagnosis Following Display Condition

### 2-1. All or 1/2 of the screen doesn't be shown

- (1) In case of all of the screen doesn't be shown, Confirm the 8pin connection of X B/D to Z B/D is well plugged in which is correspond
- (2) In case of 1/2 of the screen doesn't be shown
  - ① XR B/D
    - Confirm the 60pin connection of CTRL B/D to XR B/D is well plugged in which is correspond
  - ② XL B/D
    - Confirm the 5pin connection of XR B/D to XL B/D is well plugged in which is correspond
    - Confirm the 60pin connection of CTRL B/D to XL B/D is well plugged in which is correspond
- (3) Replace relevant X B/D.

#### \* Relationship between screen and X B/D

|                         |    |             |
|-------------------------|----|-------------|
| Screen                  |    | X B/D       |
| Left of the Screen 1/2  | ←→ | Right X B/D |
| Right of the Screen 1/2 | ←→ | Left X B/D  |

#### \* Screen Display Form

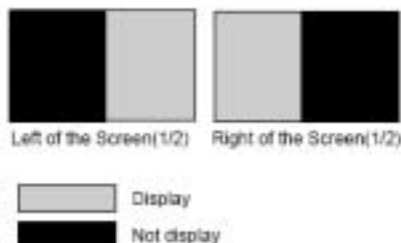

#### \* 1/4 of the screen doesn't be shown

Equality with 2-1

### 2-2. The screen doesn't be shown as Data TCP

(include not be shown part of DataTCP quantity or a part)

- (1) The problem between Data TCP and X B/D is more possible that the screen is not be shown as data TCP.
- (2) Confirm the connector of Data TCP is well connected to X B/D. Correspond to the part that screen is not showing
- (3) Confirm whether the Data TCP is failed.  
(Inclusion examination with the naked eye(IC Burnt and others)
  - ① IC is Fail. Replace the Module
  - ② In case of shorting the X B/D by foreign or PCB pattern is open: When TCP IC is not Fail, replace the X B/D.

#### \* Example of the screen display form

(Anything of the 14 Data TCP can be shown beside below pictures)

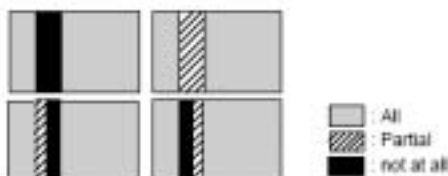

#### \* How to examine Data TCP IC

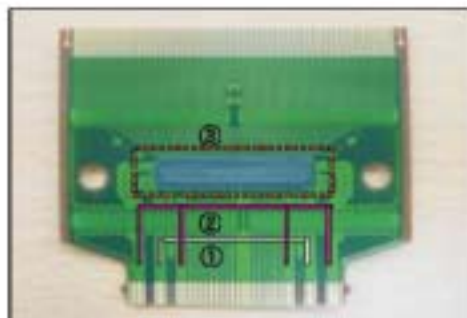

- Change ①(Va Power) into CATHOD, ②(GND) into ANODE and then examine the Diode to the forward or reverse direction.
- Burnt of ③(IC) and others examine with the naked eye.

### 2-3. It Generates Unusual Pattern of Data TCP IC unit

- (1) In case of generating unusual pattern of Data TCP IC unit as below picture, there is problem in the Signal(CLK, data, STB) or connector that is input into Data TCP IC
- (2) In case of <case 1>
  - Confirm the connection of Data TCP connector and IC Fail.
  - Replace the relevant X B/D.
- (3) In case of <case 2>, <case 3>
  - Confirm the connection of Data TCP connector and connector that is connected from CTRL to X B/D.
  - Check the foreign on the CTRL B/D and X B/D.
  - Replace the relevant X B/D or CTRL B/D.
- (4) In case of <case 4>, <case 5>
  - Confirm the connector that is connected from CTRL to X B/D
  - Replace relevant X B/D or CTRL B/D
  - Confirm the connection of Z B/D and XR B/D(8pin), XR B/D and XL B/D(5pin) power connector.

### 2-4. Regular Stripe is Generated about the Quantity of one Data TCP IC or more

- (1) In case of generating regular stripe about the quantity of one Data TCP IC or more, check the connection of connector or foreign.
- (2) Confirm the connection connector/foreign of XB/D or CTRL B/D to X B/D correspond to unusual screen.
- (3) Replace relevant XB/D or CTRL B/D.

#### \* Screen Display Form

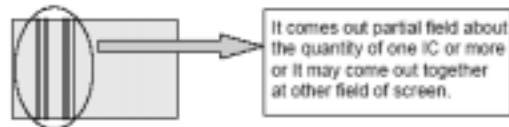

#### \* Screen Display Form

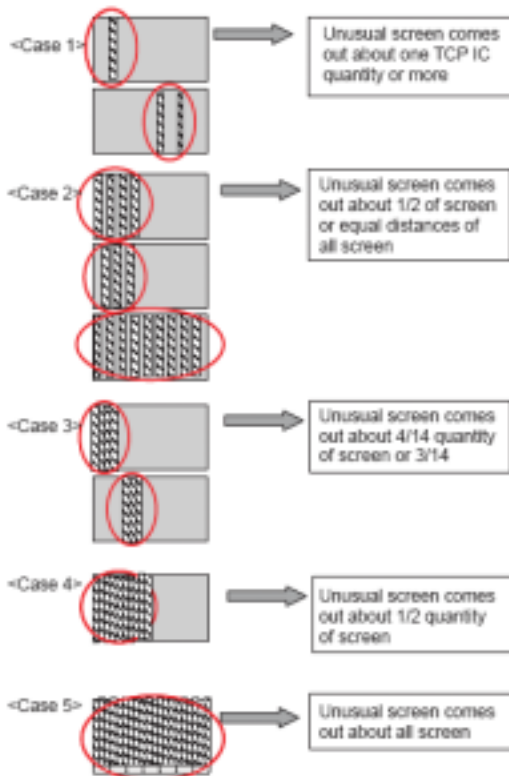

**2-5. The screen display has a problem for Scan FPC.**

- (1) It's may be a problem between Scan FPC and Y DRV B/D.
- (2) Check the connection of Y DRV B/D and Scan FPC.
- (3) If the Scan IC is failed, replace the Y DRV B/D.

■ **Screen Display Form**

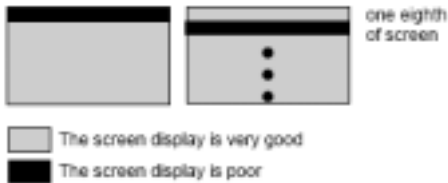

■ **Check a method of SCAN IC**



Change the Vpp Pin into ANODE and GND Pin into CATHOD and then test the Diode with forward or reverse direction.

**2-6. The screen has a vertical line with regular gap.  
(A vertical stripe flash at especial color)**

- (1) This is a problem about CTRL B/D.
- (2) Replace the CTRL B/D.

■ **Screen Display Form**

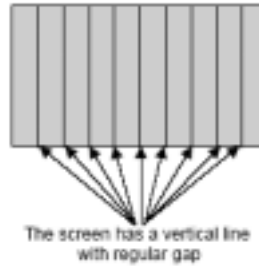

**2-7. A data copy is happened into vertical direction**

- (1) In this case, it's due to incorrect marking of scan wave.
- (2) Replace the Y DRV B/D or Y B/D.

■ **Screen Display Form**

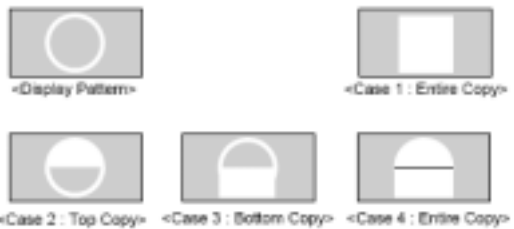

**2-8. The screen has one or several vertical line**

- (1) In this case, it isn't a problem about CTRL B/D or X B/D.
- (2) It may cause followings.
  - It's out of order a panel
  - Open or short of DATA TCP FPC attached panel
  - It's out of order a DATA TCP attached panel
- (3) Replace Module.

■ **Screen Display Form**



**2- 9. The screen has one or several horizontal line**

- (1) In this case, it isn't a problem about CTRL B/D or Y B/D.
- (2) It may cause followings.
  - It's out of order a panel
  - Open or short of SCAN FPC attached panel
  - It's out of order a SCAN IC attached panel
- (3) Replace Y DRV B/D

■ **Screen Display Form**



**2-10. The screen displays input signal pattern but the brightness is dark**

- (1) In this case, Z B/D operation isn't complete.
- (2) Check the power cord of Z B/D.
- (3) Check the connector of Z B/D and CTRL B/D.
- (4) Replace the CTRL B/D or Z B/D.

**2-11. The screen displays other color partially on full white screen or happens discharge partially on full black screen.**

- (1) Check the declination of Y B/D set up, set down wave.
  - (2) Measure each output wave with oscilloscope(more than 200MHz) and compare the data with below figure data. Adjust the Y B/D Set\_up(A) and Set\_down(B) declination by changing VR1 and VR2 as same writing on the adjustment label.
- Measuring Point of Y B/D : B39

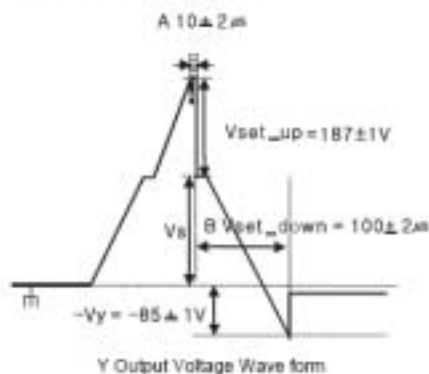

**2-12. It doesn't display a specified brightness at specified color**

- (1) Check the connector of CTRL B/D input signal.
- (2) Replace the CTRL B/D.



### 3. Checking for Component Damage

#### 3-1. Y IPM(IC 15) or Z IPM(IC 2) Damage

- (1) When the internal Sustain\_IGBT or ER\_FET of Y IPM(IC 15) or Z IPM(IC 2) is damaged, VS FUSE is open and screen doesn't be shown.
- Test Point: B32-GND(Y B/D), B28-GND(Z B/D)
  - Wave format: B32(Y B/D) or B28(Z B/D) has no output wave.

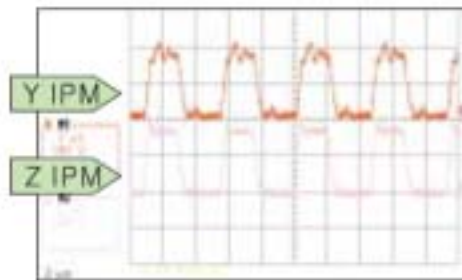

<IPM Normal Output Wave>

- Measurement position: Sustain section enlarge the after measuring B32 wave of Y B/D and B28 wave of Z B/D. (Full White Pattern)

#### 3-2. Pass Top FET(Y B/D: HS2) Damage

- (1) When Pass Top FET is damaged, electric discharge of entire screen is generated.
- Test Point: Enlarge the after measuring GND-B32(Y B/D)
  - Wave format: When the Set\_dn does not descend until -Vy.

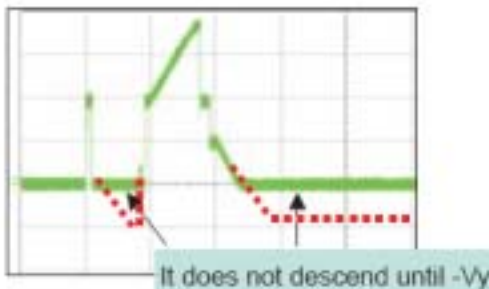

<When the Pass Top FET is damaged>

#### 3-3. FET Ass'y(Y B/D: HS1) Damage

- (1) When Set\_Up FET is damaged, screen doesn't be shown
- Test Point: Enlarge the after measuring GND-B32(Y B/D)
  - Wave format: Set\_up waveform does not come out.

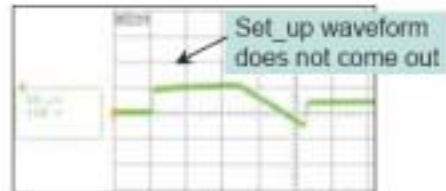

<When the Set\_Up FET is damaged>

- (2) When Set\_Down FET is damaged, electric discharge of entire screen is generated.

- Test Point: Enlarge the after measuring GND-B32(Y B/D)
- Wave format: Set\_down waveform does not come out.

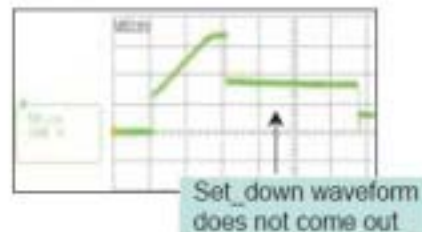

<When the Set\_Down FET is damaged>



<Reset section normal output wave>

- Measurement position: Reset section enlargement wave of B32(Y B/D) (Full White Pattern)

### 3-4. SCAN IC(Y DRV B/D: IC1-8) Damage

(1) In case of SCAN IC poor, one horizontal line may open at screen.

- Test Point: ICT measurement of GND-Y DRV B/D output
- Wave format: As shown below figure.

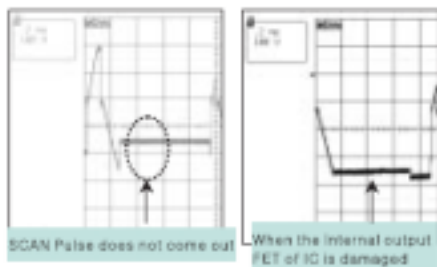

<When SCAN IC is poor>

(2) Screen may not shown when SCAN IC is damaged by SCAN IC poor, external electricity or spark.

- Test Point: ICT measurement of GND-Y DRV B/D output
- Wave format: Output wave format isn't output (You can see the damage for Y DRV B/D Top or Bottom's SCAN IC)

(3) Screen shaken horizontally when Y DRV B/D Top and Bottom cable is poor

- Test Point: ICT measurement of GND-Y DRV B/D output
- Wave format: As shown below figure.

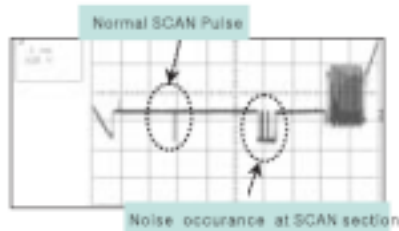

<When Y DRV B/D Top and Bottom cable is poor>

(4) In case of shoring the SCAN IC output by a dust, foreign substance, it may overlap two horizontal lines on screen.

- Test Point: ICT measurement of GND-Y DRV B/D output
- Wave format: As shown below figure.

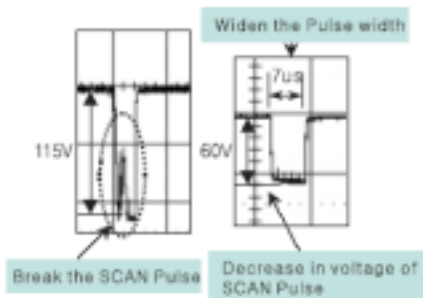

<When SCAN IC output is short>

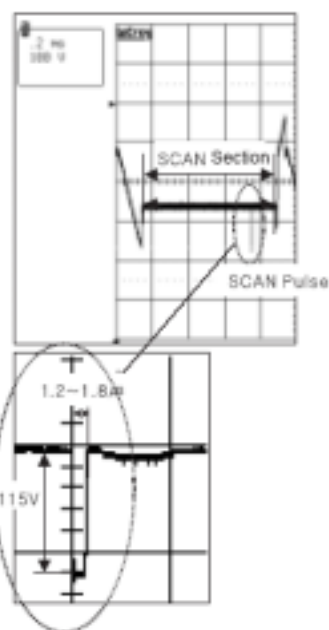

<SCAN IC Normal Output Wave >

- Measurement position: SCAN section enlarge the after measuring output ICT of Y DRV B/D. (Full White Pattern)

### 3-5. TCP Damage

(1) In case of shorting or opening the IC output of TCP, it may show one or several vertical lines.

- Test Point: Enlarge the after measuring output TP of GND-TCP
- Wave format: As shown output below figure.

In case of normal wave output, when STB signal is generated, maintain High output. And when STB signal is generated again must be fall Low.

But when IC of TCP is poor, STB signal is not generated Output falls with Low.

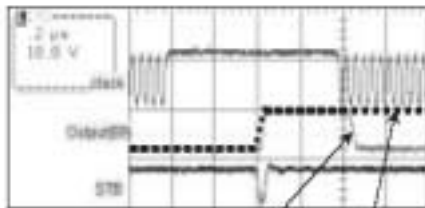

It's out of order output

In case of normal output, it may show as a dotted line

<When IC output of COF is poor>

(2) In case of being damage IC of TCP or power resistance, the screen doesn't be shown or happens discharge partially.

- Test Point: Enlarge the after measuring output TP of GND-TCP
- Wave format: Output wave doesn't come out

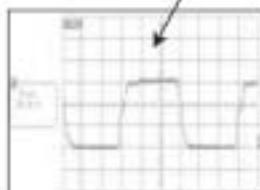
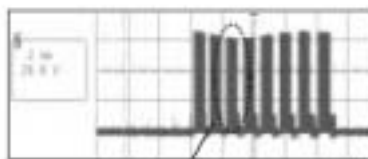

<TCP Normal Output Wave >

- Measurement position: Enlarge the after measuring output TP of TCP (Full White Pattern)

### 3-6. Crystal(CTRL B/D: X1) Damage

(1) When Crystal is damage, the screen doesn't be shown.

- Test Point: Measuring 3pin of GND-Crystal(CTRL B/D: X1)
- Wave format: Output wave doesn't come out

(2) In case of unusual launch of the Crystal, it may blink the screen.

- Wave format: As shown below figure

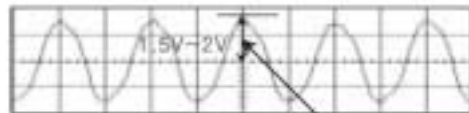

Output voltage of the signal is low

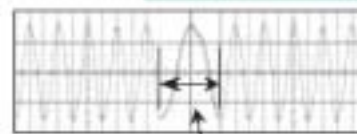

It's may change the frequency, suddenly

<When Crystal is poor>

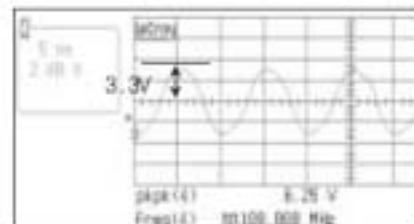

<Crystal Normal Output Wave >

- Measurement position: Measuring output 3pin of Crystal(X1: 100MHz) on CTRL B/D (Full White Pattern)

## 4. Shift breakdown component compatibility consideration

### 4-1. Scan IC follows in application, compatibility of Y DRV Top, Bottom B/D

- (1) When B/D applied FD3284F is breakdown, you must mutually only replace Top B/D and Bottom B/D applied FD3284F.
- (2) When IC of B/D applied FD3284F IC is breakdown, you must only replace FD3284F IC.  
Different IC application being not right

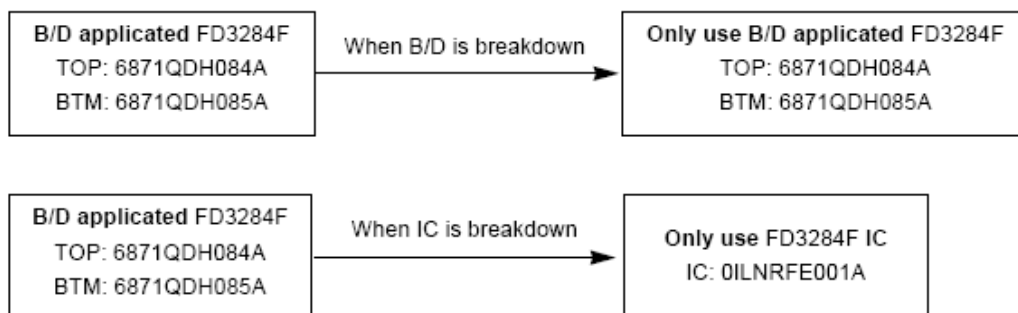

- \* When replacing the IC, notice  
To prevent dust, fix the same IC after removing the silicon  
and then it again stick the IC.

Silicon Part No.: 7254Q00002A(Tube Type)  
7254Q00002B(Can Type)

### c. Power specification

#### (1).Output voltage

| Output Name    | Output Typical(V) | *2Over Current Protection (A) | Over Voltage Protection(V) | Short circuit protection |
|----------------|-------------------|-------------------------------|----------------------------|--------------------------|
| *1 5V stand_by | 5.0               | 1.9 or more                   | 5.5~7                      | No hardware failure      |
| 5Vctrl         | 5.0               | 5~10                          |                            |                          |
| 5Vsc           | 5.0               | 5.4 or more                   |                            |                          |
| 9Vsc           | 9                 | 2.4 or more                   | 11~15                      |                          |
| 12Vsc          | 12                | 1.2 or more                   | 13~17                      |                          |
| Vaudio         | 24                | 1.75 or more                  | 26~35                      |                          |
|                | 30                | 1.5 or more                   | 38~50                      |                          |
| Va             | 60                | 1.5~3.0                       | 67~80                      |                          |
| Vs             | 190               | 1.4~3.0                       | 205~220                    |                          |

\*1. 5Vstand\_by Voltage must return automatically after a problem is eliminated.

\*2 The O.C.P point is measured by resistor load when other output load is a maximum.

( The Output voltage must keep normally at moment peak current of PDP.)

The O.C.P point is load current when the output voltage decrease to 0 ( shut down )

No hardware failure and No fire

#### (2). Micro Controller control signal

##### Input signal(to PSU):

RLY signal ( High : Low Voltages\*1are ON Low : Low Voltages are OFF)

VS ON signal (High : High Voltages\*2are ON Low : High Voltages are OFF)

##### Output signal(from PSU)

ACD signal (High : 75V < AC Input Voltage Low : 70V > AC Input Voltage)

5VD signal(High : Module logic Voltage\*3is 5V Low : Module logic Voltage is 0V)

\*1. Low Voltages : 5Vstand-by , 5Vsc, 9Vsc, 12Vsc, Vaudio

\*2. High Voltages : Va, Vs

\*3. Module logic Voltage : 5Vctrl

### (3).PSU ON/OFF sequence

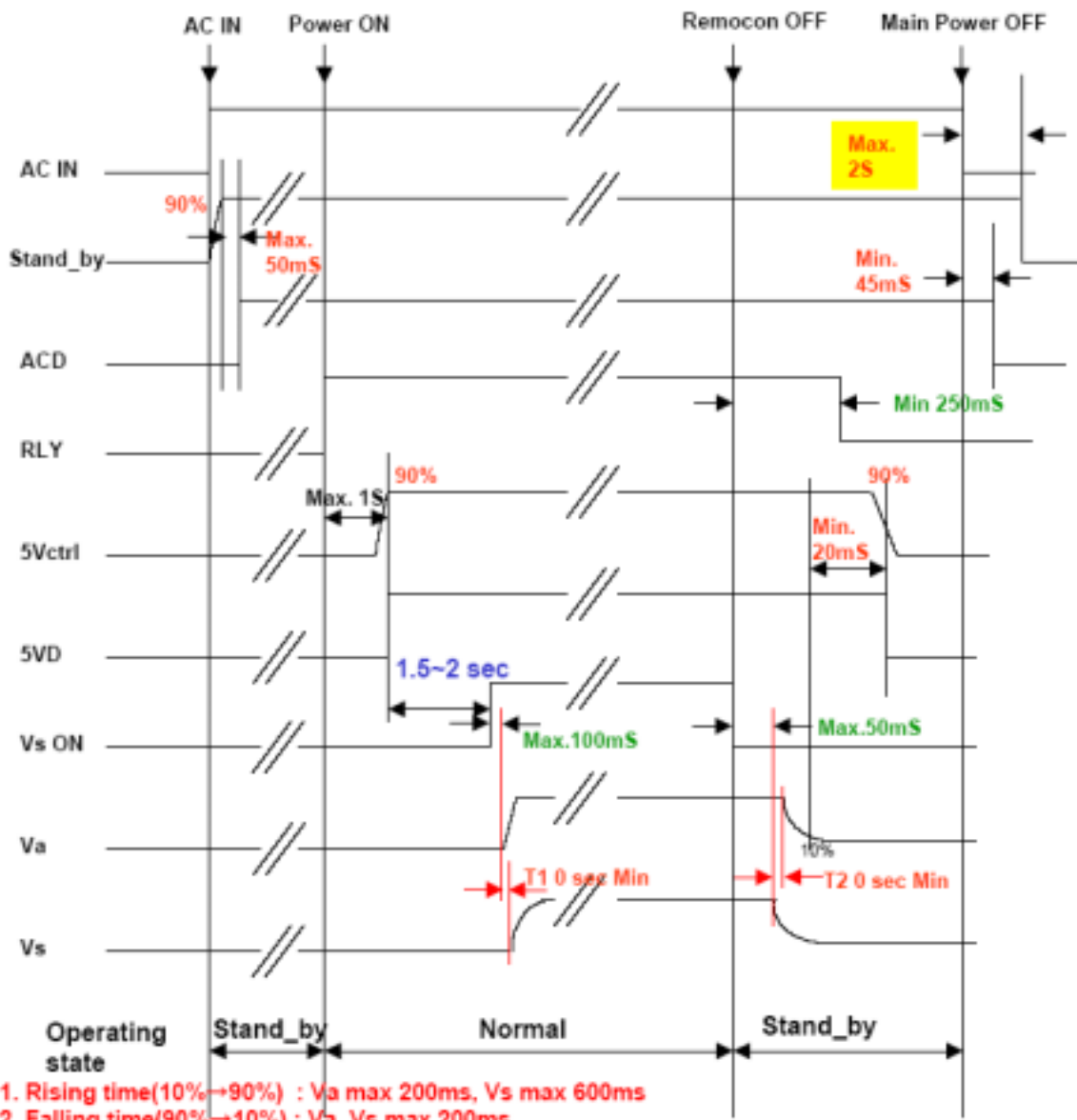

1. Rising time(10%→90%) : Va max 200ms, Vs max 600ms

2. Falling time(90%→10%) : Va, Vs max 200ms

※ Although the user turns power S/W off and turn it on momentarily, all output voltage and signals except for standby power should be reset.

(4).PSU INPUT/OUTPUT PIN

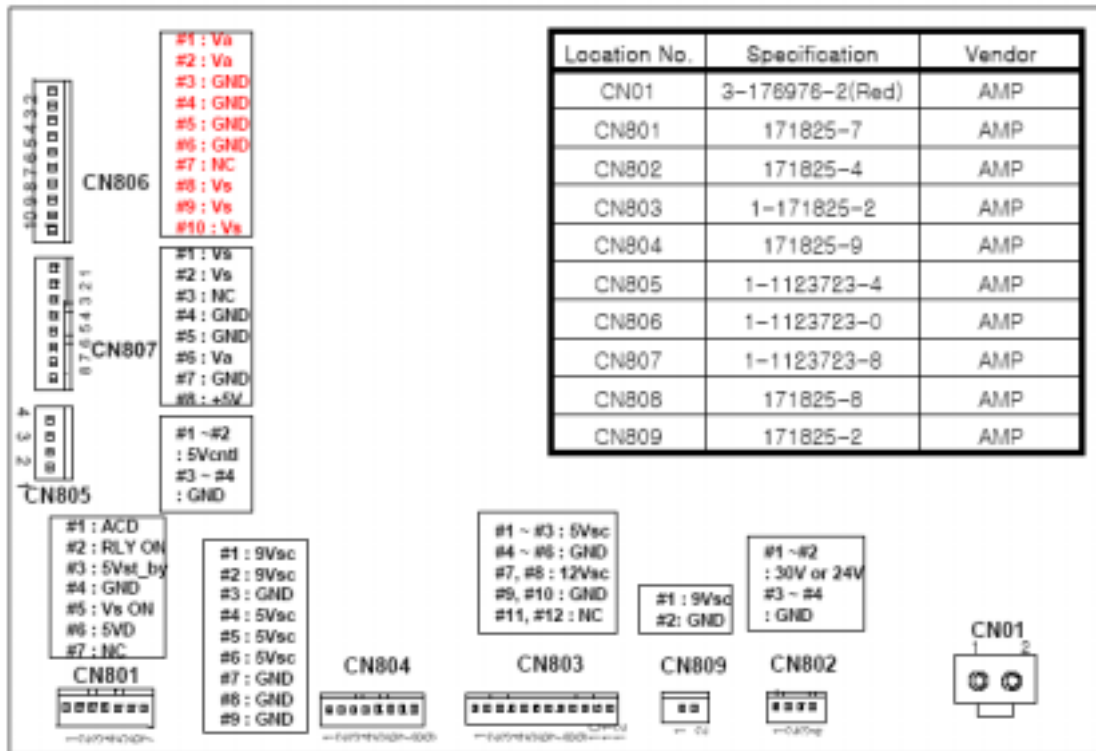

## 6. Introduction to PDP circuit boards

### a: Signal flow-chart

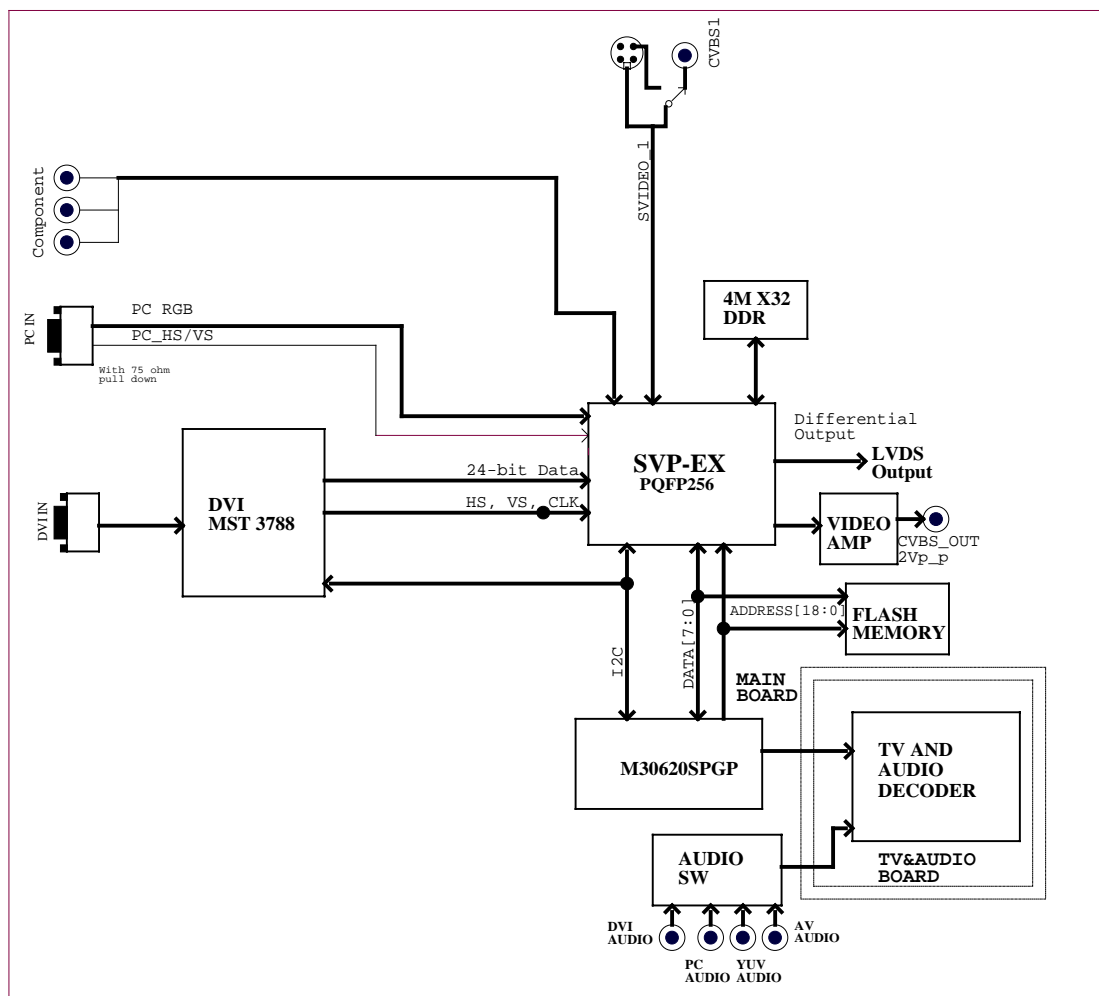



## **b: CHIP SUMMARY**

### **M30620: 16-BIT CMOS SINGLE-CHIP MICROCOMPUTER**

The single-chip microcomputer operate using sophisticated instructions featuring a high level of instruction efficiency. With 1M bytes of address space, they are capable of executing instructions at high speed. In addition, this microcomputer contains a multiplier and DMAC which combined with fast instruction processing capability.

### **SVP-EX52: VIDEO DECODER+DE-INTERLACE+SCALE**

The SVP\_EX-52 video processor is a highly integrated system on a chip device, targeting the converging HDTV-ready and PC-ready and LCD TV, PDP TV, and DLP TV applications where high precision processing of video and data are the requirements. SVP\_EX-52 contains dual-purposed triple 10-bit high-precision and high-speed video ADCs for both PC and video inputs, a high performance 5th generation multi-format 3D digital comb video decoder that supports NTSC, PAL and SECAM, an HDTV sync separator, motion adaptive de-interlacing engine, and the video format conversion engine,

### **MST3788: 8-bit Analog and HDCP Interface for Advanced Digital Displays**

The MST3788 integrates both analog interfaces and HDCP compliant receivers for enabling advanced digital display devices such as digital TVs, plasma displays, LCD TVs and projectors to receive and display. Compliant with the HDCP 1.0 specification, the MST3788 enables consumer electronic devices to receive uncompressed, high quality, digital video HD content over a single, low-cost DVI cable.

### **MSP3450G: AUDIO DECODER**

The MSP 34x0G family of single-chip Multistandard Sound Processors covers the sound processing of all analog TV-Standards worldwide,

### **K4D263238F: 128M DDR SDRAM**

### C: Debug flow-chart

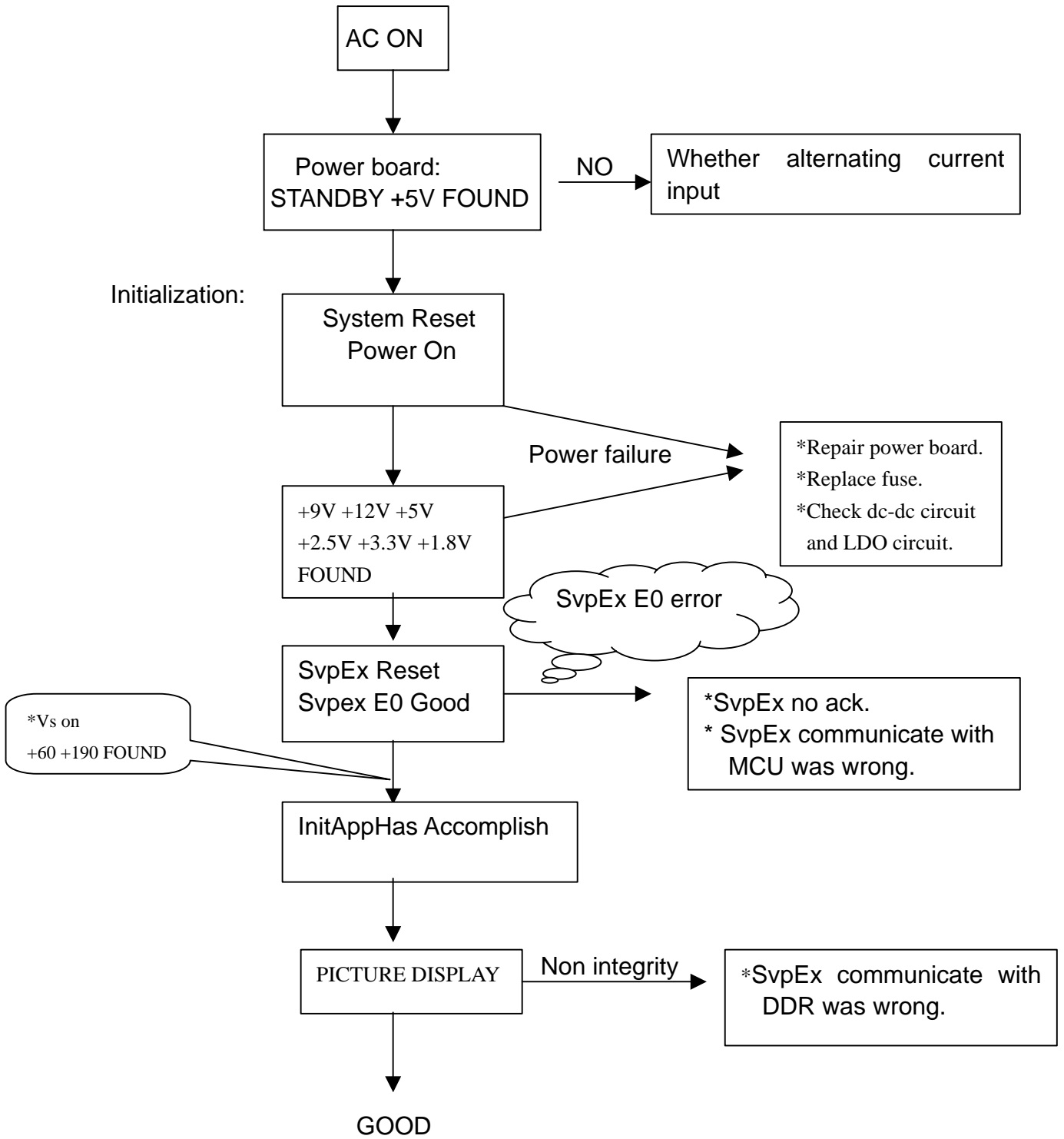

# REVISION HISTORY OF 42PDP TV REFERENCE BOARD

| REV  | DATE         | DESCRIPTION   | SIGNATURE |
|------|--------------|---|-----------|
| A-00 | May 9 2004   | DRAFT RELEASE   | Liuchy    |
|      | June 18 2004 | CPU SDA5550M CHANGE TO M30620SPGP<br>video decoder vpc3230d change to SAA7117A<br>DVI CHANGE HDMI   | Liuchy    |
|      | July 24 2004 | add audio input circuit   | Liuchy    |
| A-01 | Nov. 16 2004 | 1.HDMI IC SiI9993 CHANGED TO MST3288<br>2.SVP_EX PIN18(FIELD I/O) CONNECTED TO MST3288 PIN71.<br>3.U3 DDRSDRAM PIN52(MCL) ADDED R282 FOR SAMSUNG AND HYUNGAI DDR OPTION.<br>4.MST3288 ADDED VGA INPUT AND YUV INPUT.<br>5.CN9 8PINS CHANGED TO 10PINS FOR 4 DIGITAL AUDIOS OUT IN MST3288.<br>6.U8 ADDED R367,R368,RP45,RP46,R272,R274,R275,R278,R370,R369,R371 FOR COMPATIBILITY OF SAA7117AH AND SAA7119H.<br>7.SAA7117AH PIN44(CE) INPUT DIVIDED VOLTAGE CIRCUIT BE DELETED.<br>8.U11 CPU PIN3'S OUT BUFFER BE DELETED.<br>9.U11 CPU PIN7(CNVSS) ADDED R365 PULL UP RESISTER FOR EXTENSE ROM MODE'S SELECTION.<br>10.ADDED U17 CS4334 FOR COST DOWN OF DIGITAL AUDIO D/A PROCESSOR.<br>11.DELETED U17 PI5V330 AND YUV INPUT BUFFER.<br>12.U18,U21 ADDED 7117_CE NET AND RST_#5V NET'S LEVEL FROM +5V TO 3.3V CIRCUIT.<br>13.ADDED FB31,FB32,CN35 3.3V POWER INPUT CONNECTOR FOR OUTSIDE POWER SUPPLY DESIGN OPTION.<br>14.CPU 90PIN(CE_REMOT) AND 74PIN(S-VHS/V1#_SW) NET'S definition EXCHANGED.<br>15.ADDED TUNER IC U31<br>16.DELETED CN26,CN27 PIN 9,10 OF definition HAVED CHANGED. | Liuchy    |
| A-02 | Dec. 30 2004 | 1.Added EX52 CVBSOUT R121,R125,C220<br>2.Chang EX52 PIN186,204,65,19 from VD3.3 to 3.3V_SB and a regulator U32 from 5V_SB to 3.3V_SB.<br>3.SAA7117H DELETED RP26,RP27,RP28,RP29<br>4.ADDED a regulator U33 from 3.3V to 1.8V TO SAA7117H AND XC2028.<br>5.R21 10K CHANGED TO 1K.<br>6.DELETED R284,R285 AND ADDED Y4 CRYSTAL.<br>7.ADDED FB40 FOR VDDH3_3 NET.<br>8.C344 VCC NET CHANGED TO AVCC NET.<br>9.C70,C97,C100,C104,C105,C117,C118,C120 CHANGED FROM 1000pF TO 100nF;C87,C88 CHANGED FROM 4700pF TO 100nF;C91 CHANGED FROM 10nF TO 100nF.  | Liuchy    |
| C-00 | Jan.13 2005  | 1.Added DC/DC POWER 3.3V +5V(MAIN) AND +5V FOR USB INTERFACE.<br>2.Added USB POWER CONNECTOR AND YBCRC&CONTROL INTERFACE:CN37, CN38 AND ADDED COMPONENTS:<br>R426,R427,R428,R429,R430,R431,R432,C476,C477,C478,R434,R435 DELETED C333.  |           |

|      |             |  |        |
|------|-------------|--|--------|
|      |             | 3.CN11 6PINS CHANGED TO 8PIN,THIS ADDED VIDEO OUT PIN FOR VIDEO OUT RCA TERMINAL CN40 MOVED TO EXTENDSION BOARD.<br>4.U4 ADDED USB YBCRC INPUT,MST3288 CHANGED TO MST3388,CN9 5x2 2mm CHANGED TO 4x2 2mm CONNECTOR,deleted RP47 CP8.<br>5.HDMI TERMINAL CHANGED TO DVI TERMINAL,CN34 PIN's definition were changed.<br>6.ADDED C475,R425,R433,C479,R373.<br>7.R99 TV PIP 7117_1 NET WAS DELETED.<br>8.DELETED D14 FOR CPU +5V POWER<br>9.CN28 8pins changed to 9pins:added vcc pin for led backlight and added C481.<br>10.BACKLIGHT CONNECTOR CN29 PIN's definition were changed.ADDED E_PWM NET AND ISEL NET.<br>11.DELETED +5V POWER SWITCH:U22,C264,C262,R342,R349,R351,Q14.<br>12.DELETED 3V3S LDO POWER SUPPLY:U24,C274,C275,FB21.<br>13.DELETED B3V3 LDO POWER SUPPLY:U27,C290,C291,FB26.<br>14.ADDED DC/DC POWER SUPPLY VCC,3V3S,VCC_USB.  |        |
| C-01 | Mar.12 2005 | 1.Added FB21 FOR CN3 POWER 3.3V.<br>2.Added D18-D29 FOR DVI PROTECTION.<br>3.Added R211,CN16 24PINS CHANGED TO 26PINS FOR VIDEO2 INTERFACE.<br>4.DELETED R170,CN6 PIN1 CONNECTED TO 5V_SB NET.<br>5.CN8,CN10 3PINS PHONEJACK CHANGED TO 5PIN(WITH SWITCH) PHONEJACK.<br>6.CN7 PHONEJACK CHANGED TO RCA CN40,CN7 JACK.<br>7.CN10 PHONEJACK AND CN26,CN31 RCA JACKS ARE OPTION TO DVI AUDIO INPUT TERMINALS.<br>8.C268,R284 ADDED CVBS_OUT NET FOR DC CLAMP.<br>9.CN12 PIN16 S_VOUT NET CHANGED TO CONNECTED AGND.<br>10.CN17,CN13,CN14 S/VIDEO1 TERMINALS MOVED TO TV BOARD SO DELETED R264,R266,L9,C226,R269,L10,R265,C225,R267,R268.CN11 8PINS CHANGED TO 8x2PINS WITH ADDED S/VIDEO INPUT PINS TO TV BOARD.<br>11.CN16 PIN17,19 VCC POWER ADDED L24,C107 FILTER.<br>12.CN30 WAS DELETED.<br>13.U7 LM2937IMP-2.5 CHANGED TO LM1117BMPX-2.5,U46 78M05 CHANGED TO AZ1085D-5.0 TO-252.<br>14.U41,U42,U47 WERE ALL CHANGED TO MP1583. | Liuchy |
| C-02 | May.20 2005 | 1.DELETED U16 TEA2014.<br>2.DELETED U8 SAA7117 VIDEO OUT AMPLIFIER.  | Liuchy |
|      | Jun.20 2005 | 1.R250,R251,R253,R87,R88,R90 27R-->0R.<br>2.R255,R256,R257,R108,R115,R109 47R-->75R.   |        |
|      | Jun.28 2005 | 1.DELETED R211.(UPDATE SCH.)   |        |
| C-03 | Sep.23 2005 | 1.DELETED C379,C380,C384.<br>2.ADDED R402,R403,R404 75 OHM.  | Liuchy |
|      | Jan.3 2006  | 1.CN37 PINS SWAP.  |        |

| Fuzhou Walasey Technology Limited Company |                                  |               |
|---|----------------------------------|---------------|
| Title<br>Revision History                 |                                  |               |
| Size<br>B                                 | Document Number<br>42PDP_TV_MAIN | Rev<br>C-03   |
| Date:                                     | Saturday, February 18, 2006      | Sheet 7 of 30 |

42PDP: SVP-EX(256) + SAA7117A + DVI- Block Diagram

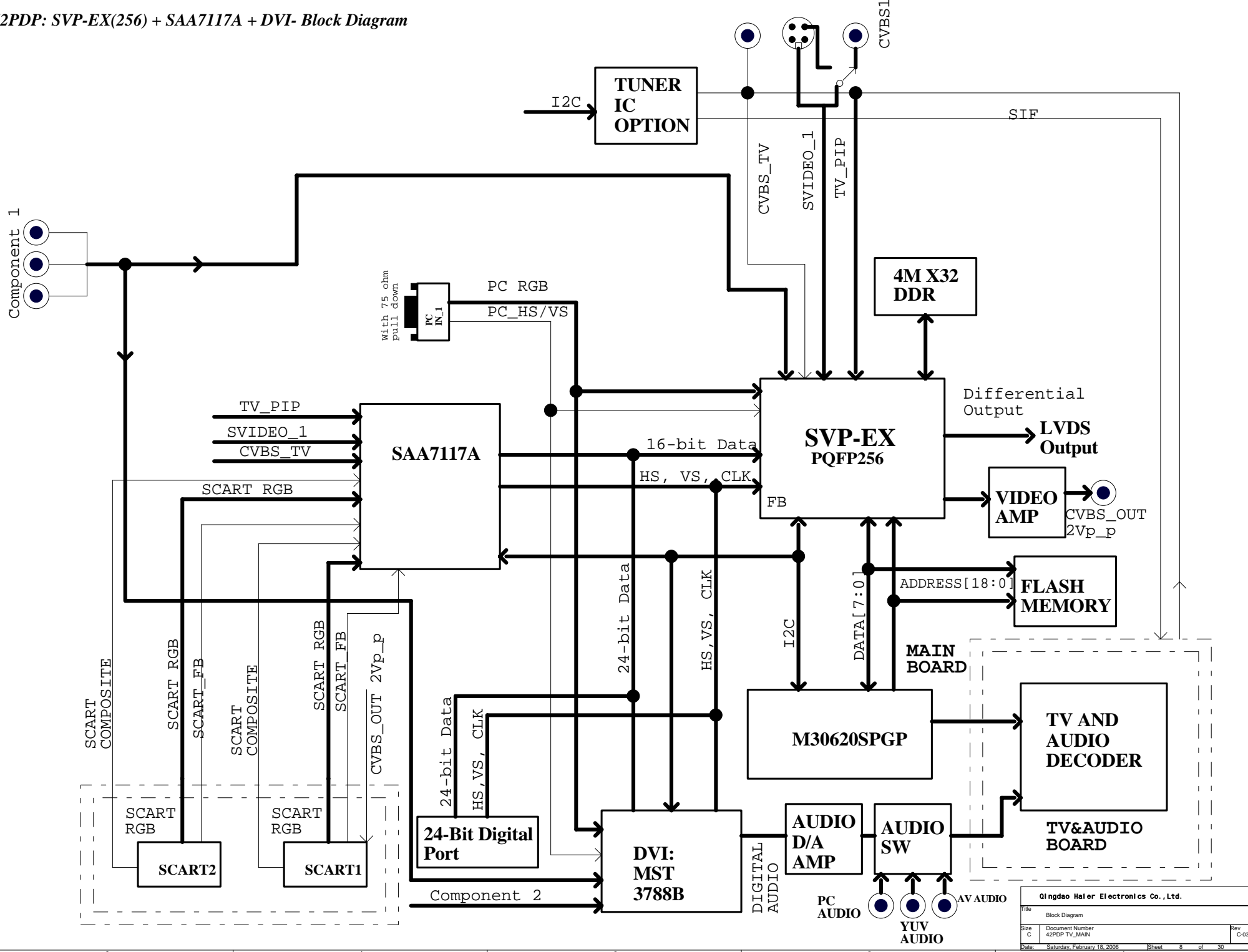

|                                     |                             |               |
|-------------------------------------|-----------------------------|---------------|
| Qingdao Haler Electronics Co., Ltd. |                             |               |
| File                                | Block Diagram               |               |
| Size                                | Document Number             | Rev           |
| C                                   | 42PDP_TV_MAIN               | C-03          |
| Date                                | Saturday, February 18, 2006 | Sheet 8 of 30 |

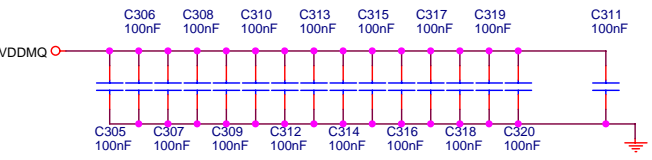

**Test pads for DDR**

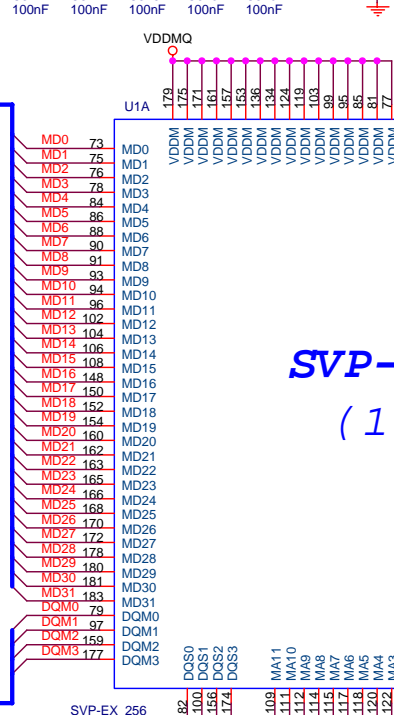
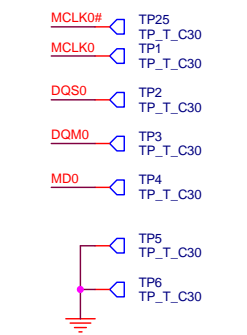

**SVP-EX [256]**  
(1 of 2)

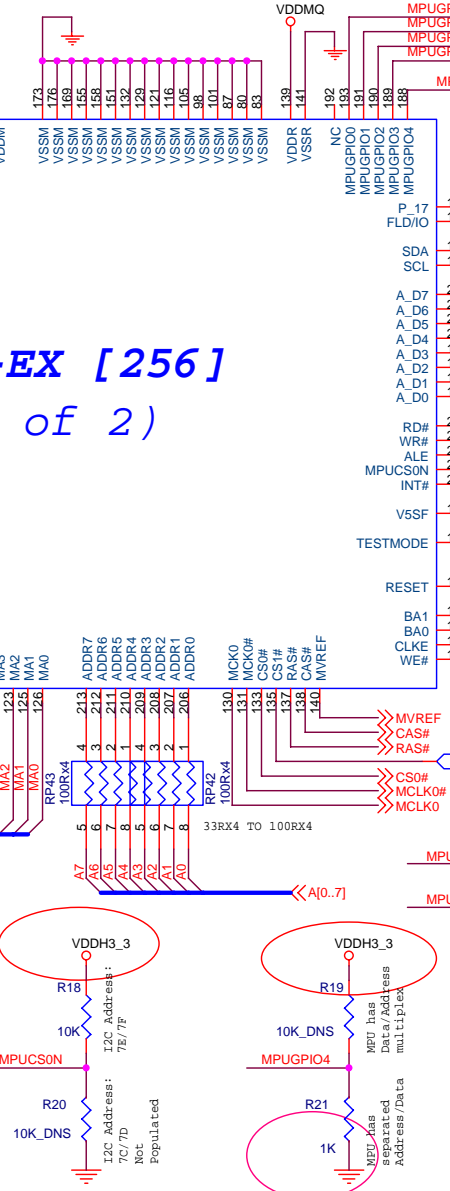
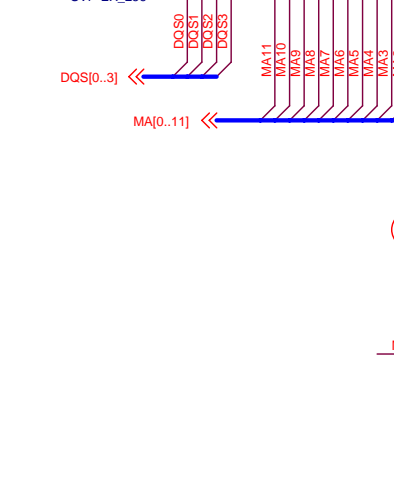

if not a test pad, an enlarged via underneath the chip or exposed trace. Possible DQS MCLK exposed trace, DQ enlarged via

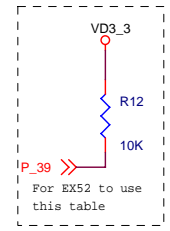
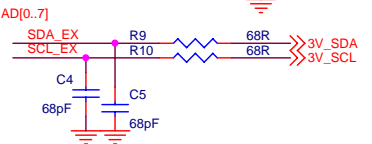
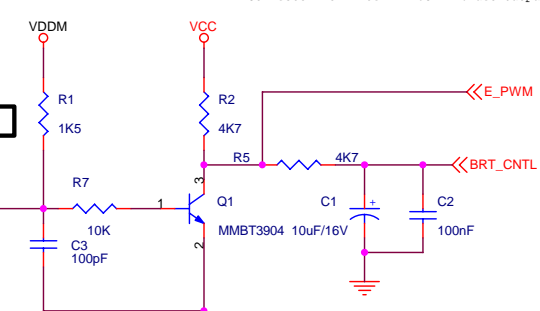
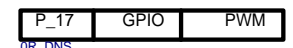

| INPUT    |          | OUTPUT  |       |          |          |
|----------|----------|---------|-------|----------|----------|
| MPUGPIO1 | MPUGPIO0 | MPUCS0N | *CS1N | MPUGPIO2 | MPUGPIO3 |
| 0        | 0        | 0       | 1     | 1        | 1        |
| 0        | 1        | 1       | 0     | 1        | 1        |
| 1        | 0        | 1       | 1     | 0        | 1        |
| 1        | 1        | 1       | 1     | 1        | 0        |

\*CS1N is not a input or output pin  
CS1N=0: SVP-EX CPU access enabled  
CS1N=1: SVP-EX CPU access disabled

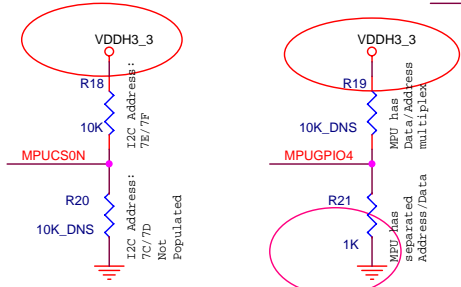

|  |                             |               |
|--|-----------------------------|---------------|
| <b>Qingdao Haier Electronics Co., Ltd.</b> |                             |               |
| Title                                      | SVP-EX 1 of 2               |               |
| Size                                       | Document Number             | Rev           |
| B  | 42PDP_TV_MAIN               | C-03          |
| Date:                                      | Saturday, February 18, 2006 | Sheet 9 of 30 |

# SVP-EX [256]

## (2 of 2)

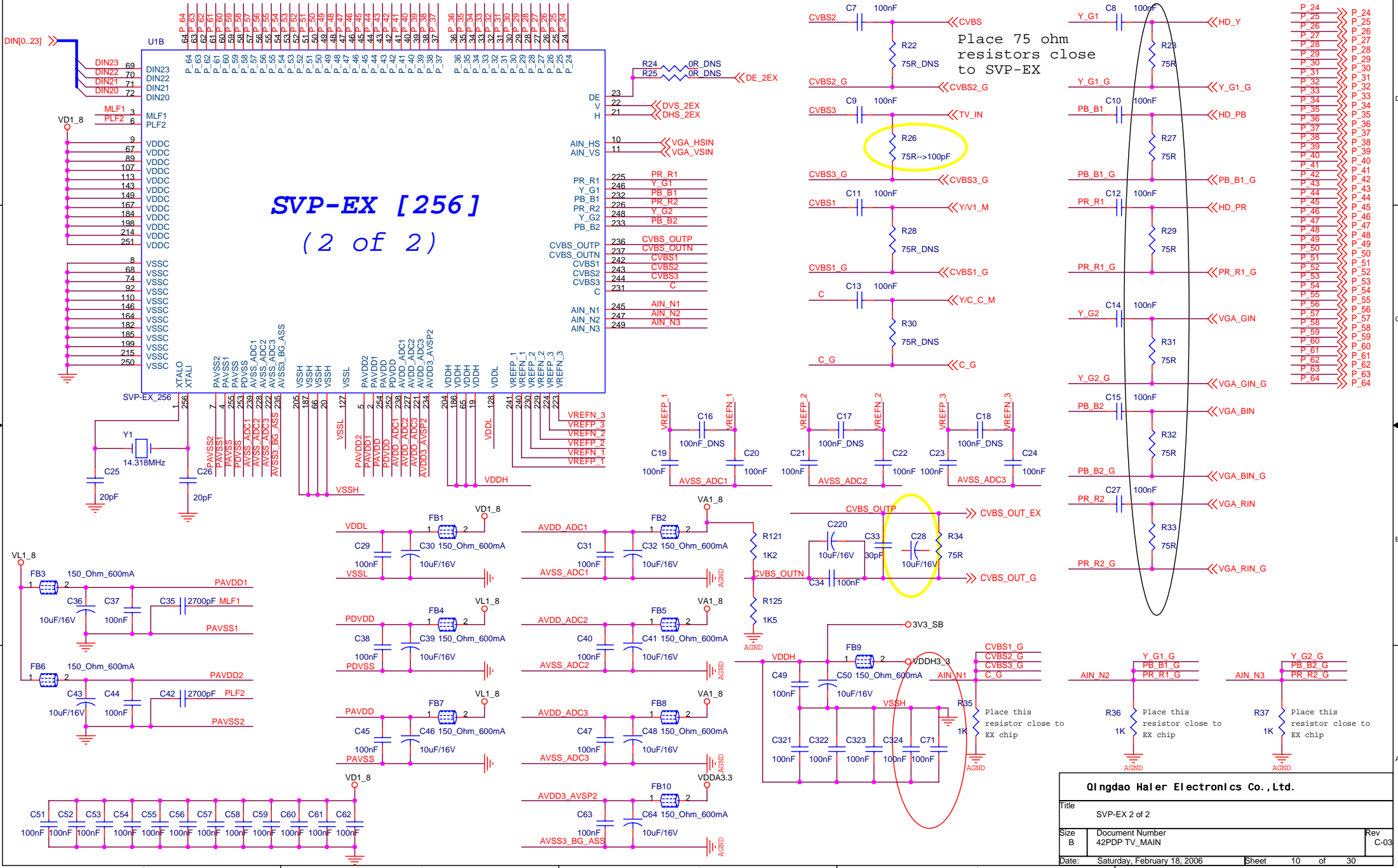

| Qingdao Haier Electronics Co., Ltd. |                             |                |
|-------------------------------------|-----------------------------|----------------|
| Title                               | SVP-EX 2 of 2               |                |
| Size                                | Document Number             | Rev            |
| B                                   | 42PDP_TV_MAIN               | C-03           |
| Date:                               | Saturday, February 18, 2006 | Sheet 10 of 30 |

|      | EX42     | EX52     |
|------|----------|----------|
| P_24 | AVSS33_3 | PLL_VCC  |
| P_25 | AVDD33   | PLL_GND  |
| P_26 | IRSET    | TXOUT3+  |
| P_27 | AVSS33_2 | TXOUT3-  |
| P_28 | B_OUT    | TXCLK+   |
| P_29 | G_OUT    | TXCLK-   |
| P_30 | R_OUT    | TXOUT2+  |
| P_31 | VM       | TXOUT2-  |
| P_32 | AVSS33_1 | LVDSGND  |
| P_33 | ADVDD33  | LVDSVCC  |
| P_34 | HS/O     | TXOUT1+  |
| P_35 | HSD/O    | TXOUT1-  |
| P_36 | HFLB/O   | TXOUT0+  |
| P_37 | VS/O     | TXOUT0-  |
| P_38 | VDDC     | LVDSVDDP |
| P_39 | VSSC     | GPO/O    |
| P_40 | DIN19/I  | VDDC     |
| P_41 | DIN18/I  | VSSC     |
| P_42 | DIN17/I  | DIN19/I  |
| P_43 | DIN16/I  | DIN18/I  |
| P_44 | DIN15/I  | DIN17/I  |
| P_45 | DIN14/I  | DIN16/I  |
| P_46 | DIN13/I  | DIN15/I  |
| P_47 | DIN12/I  | DIN14/I  |
| P_48 | VDDH     | DIN13/I  |
| P_49 | VSSH     | DIN12/I  |
| P_50 | DIN11/I  | VDDH     |
| P_51 | DIN10/I  | VSSH     |
| P_52 | DIN9/I   | DIN11/I  |
| P_53 | DIN8/I   | DIN10/I  |
| P_54 | CLK/I    | DIN9/I   |
| P_55 | DIN7/I   | DIN8/I   |
| P_56 | DIN6/I   | CLK/I    |
| P_57 | DIN5/I   | DIN7/I   |
| P_58 | DIN4/I   | DIN6/I   |
| P_59 | DIN3/I   | DIN5/I   |
| P_60 | DIN2/I   | DIN4/I   |
| P_61 | DIN1/I   | DIN3/I   |
| P_62 | DIN0/I   | DIN2/I   |
| P_63 | NC       | DIN1/I   |
| P_64 | NC       | DIN0/I   |

- P\_24 PLL\_VCC
- P\_25 PLL\_GND
- P\_26 TXOUT3+
- P\_27 TXOUT3-
- P\_28 TXCLK+
- P\_29 TXCLK-
- P\_30 TXOUT2+
- P\_31 TXOUT2-
- P\_32 LVDSGND
- P\_33 LVDSVCC
- P\_34 TXOUT1+
- P\_35 TXOUT1-
- P\_36 TXOUT0+
- P\_37 TXOUT0-
- P\_38 LVDSVDDP
- P\_39 VDDC
- P\_40 VSSC
- P\_41 DIN19
- P\_42 DIN18
- P\_43 DIN17
- P\_44 DIN16
- P\_45 DIN15
- P\_46 DIN14
- P\_47 DIN13
- P\_48 DIN12
- P\_49 VDDH
- P\_50 VSSH
- P\_51 DIN11
- P\_52 DIN10
- P\_53 DIN9
- P\_54 DIN8
- P\_55 DIN7
- P\_56 DIN6
- P\_57 DIN5
- P\_58 DIN4
- P\_59 DIN3
- P\_60 DIN2
- P\_61 DIN1
- P\_62 DIN0
- P\_63
- P\_64

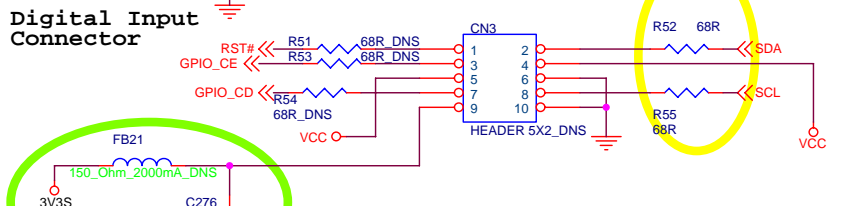
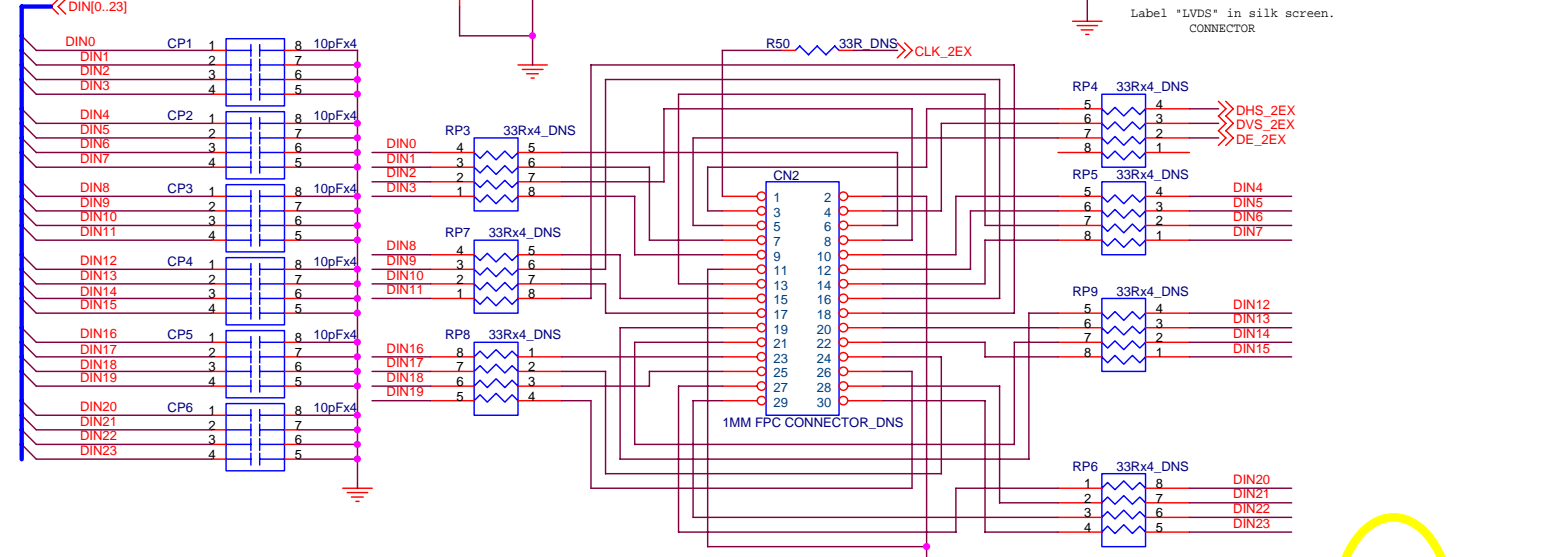
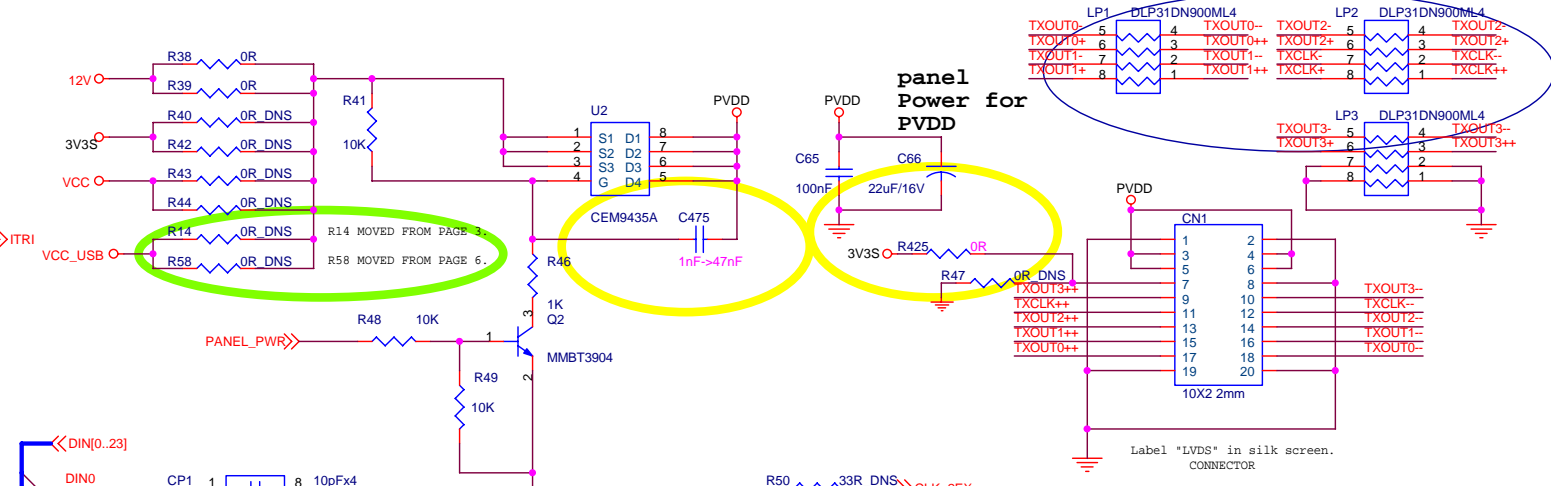
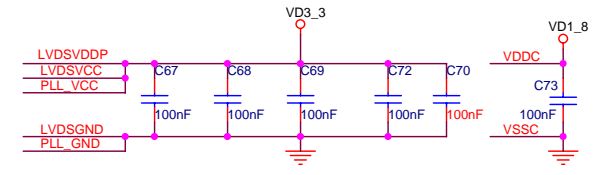

|                                     |                                |           |  |
|-------------------------------------|--------------------------------|-----------|--|
| Qingdao Haier Electronics Co., Ltd. |                                |           |  |
| Title: SVP-EX Pin Configuration     |                                |           |  |
| Size: B                             | Document Number: 42PDP_TV_MAIN | Rev: C-03 |  |
| Date: Saturday, February 18, 2006   | Sheet: 11                      | of 30     |  |

Each MD trace must be equal length.  
Each DQS trace must be equal length.

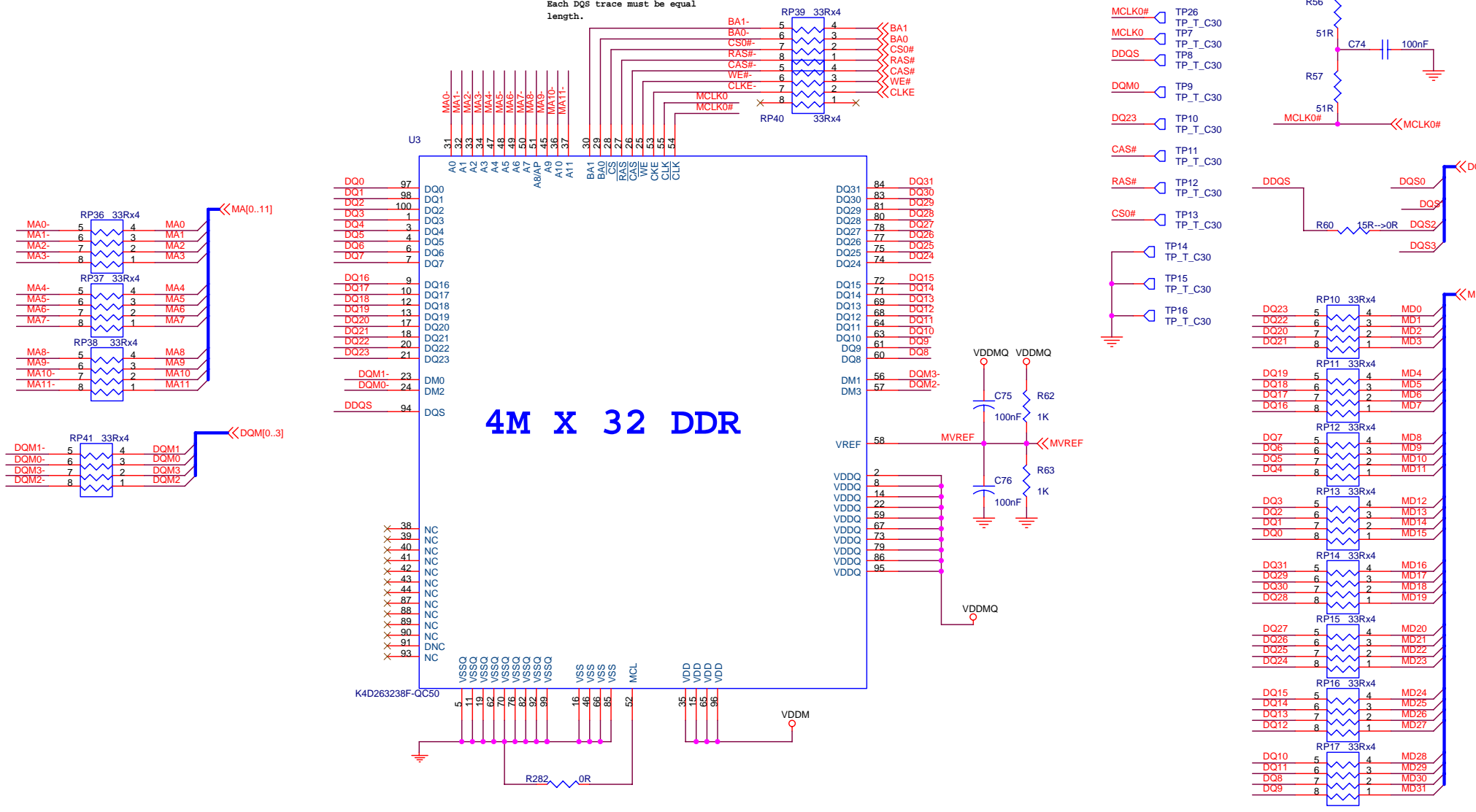

# 4M X 32 DDR

## Test pads for DDR

- MCLK0# TP26
- MCLK0 TP7
- DDQS TP8
- DQM0 TP9
- DQ23 TP10
- CAS# TP11
- RAS# TP12
- CS0# TP13
- TP14 TP\_T\_C30
- TP15 TP\_T\_C30
- TP16 TP\_T\_C30

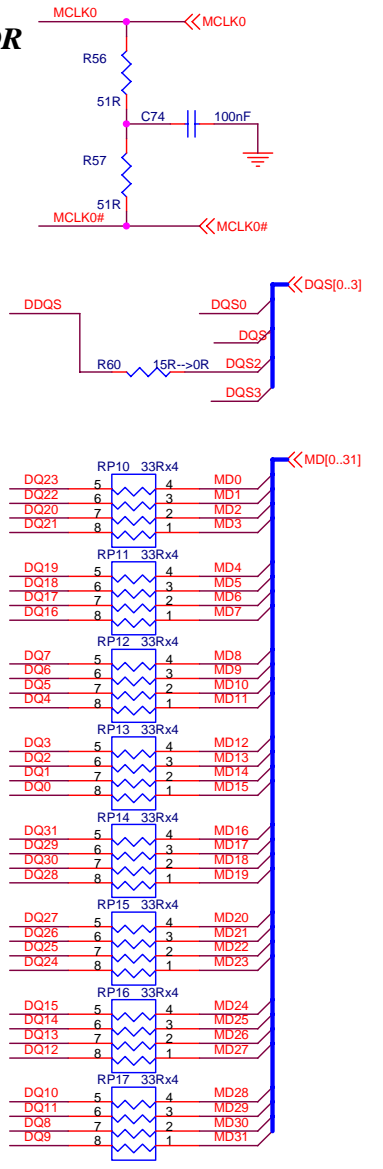

MEMORY DECOUPLING SCHEME

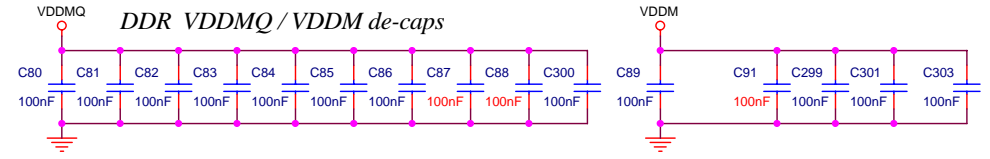
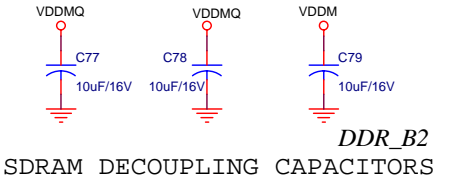

|  |                                |           |
|--|--------------------------------|-----------|
| <b>Qingdao Haier Electronics Co., Ltd.</b> |                                |           |
| Title: DDR                                 |                                |           |
| Size: B                                    | Document Number: 42PDP_TV_MAIN | Rev: C-03 |
| Date: Saturday, February 18, 2006          | Sheet: 12                      | of 30     |





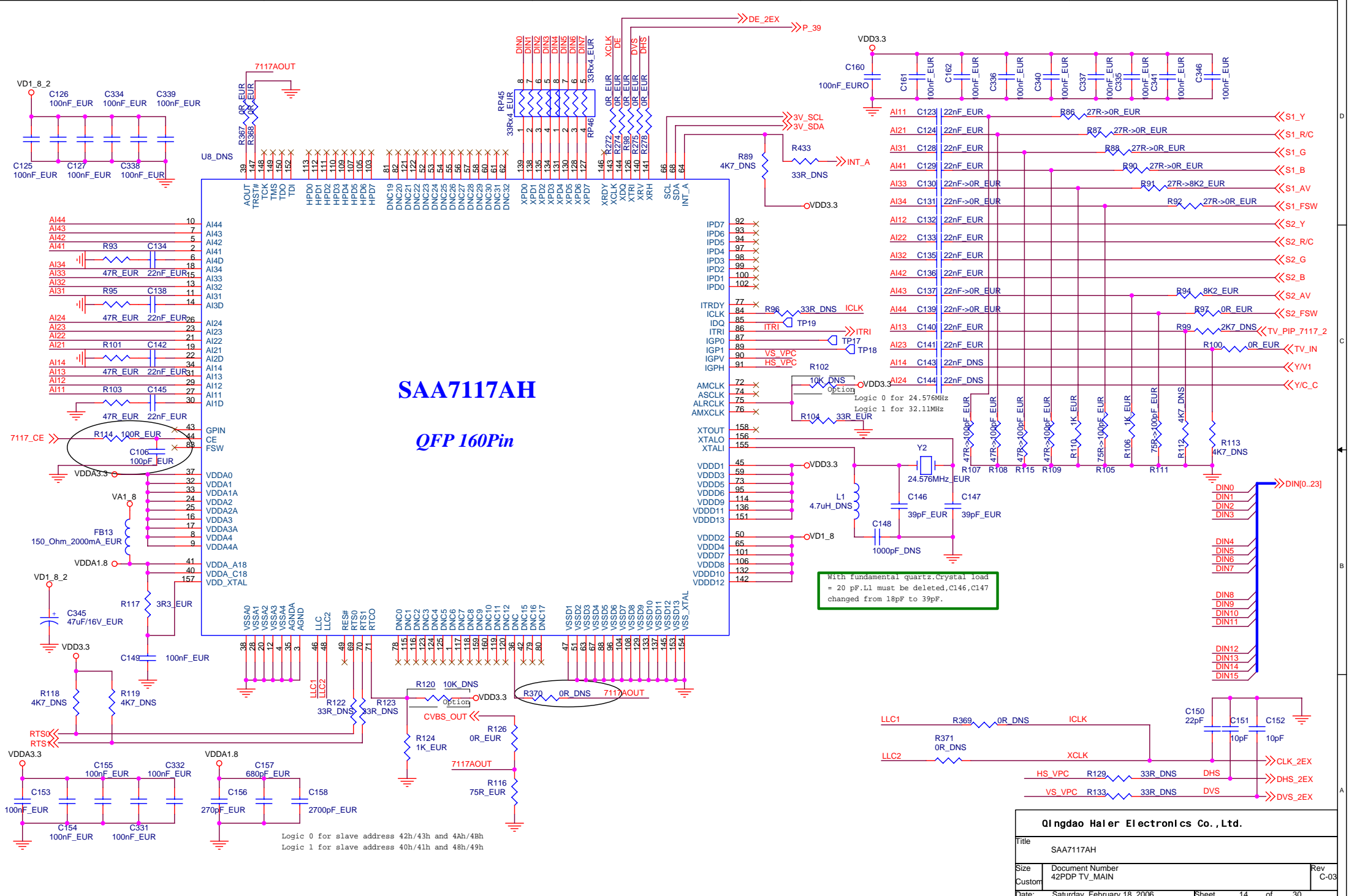

**SAA7117AH**  
**QFP 160Pin**

Logic 0 for slave address 42h/43h and 4Ah/4Bh  
Logic 1 for slave address 40h/41h and 48h/49h

|  |                             |                |
|--|-----------------------------|----------------|
| <b>Qingdao Haier Electronics Co., Ltd.</b> |                             |                |
| Title                                      | SAA7117AH                   |                |
| Size                                       | Document Number             | Rev            |
| Custom                                     | 42PDP_TV_MAIN               | C-03           |
| Date:                                      | Saturday, February 18, 2006 | Sheet 14 of 30 |

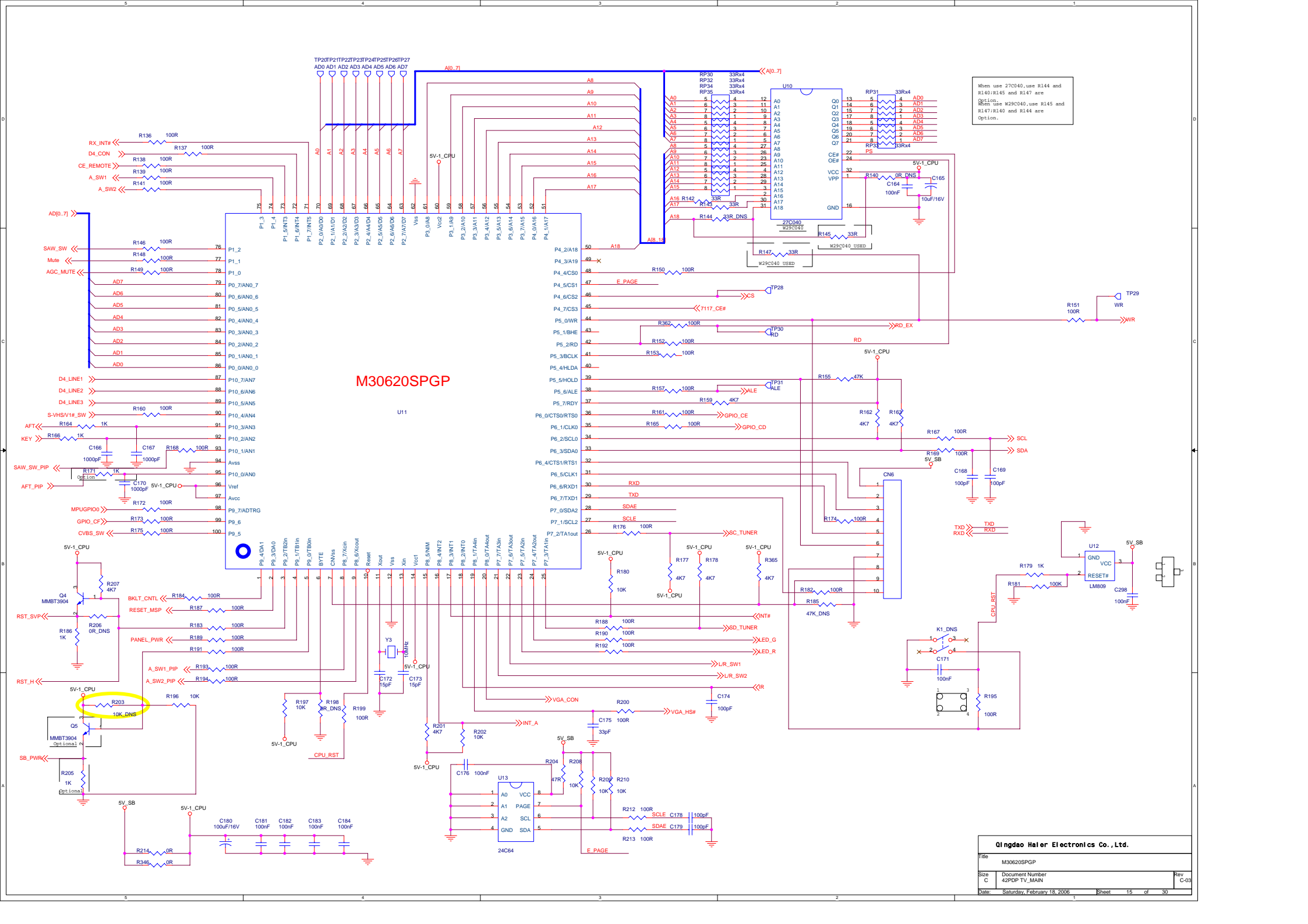

When use 27C040, use R144 and R140/R145 and R147 are  
 Option:  
 When use W29C040, use R145 and R147/R140 and R144 are  
 Option:

**M30620SPGP**

|                                     |                             |       |          |
|-------------------------------------|-----------------------------|-------|----------|
| Qingdao Haler Electronics Co., Ltd. |                             |       |          |
| File                                | M30620SPGP                  |       |          |
| Size                                | Document Number             | Rev   |          |
| C                                   | 42PDP_TV_MAIN               | C-03  |          |
| Date                                | Saturday, February 18, 2006 | Sheet | 15 of 30 |

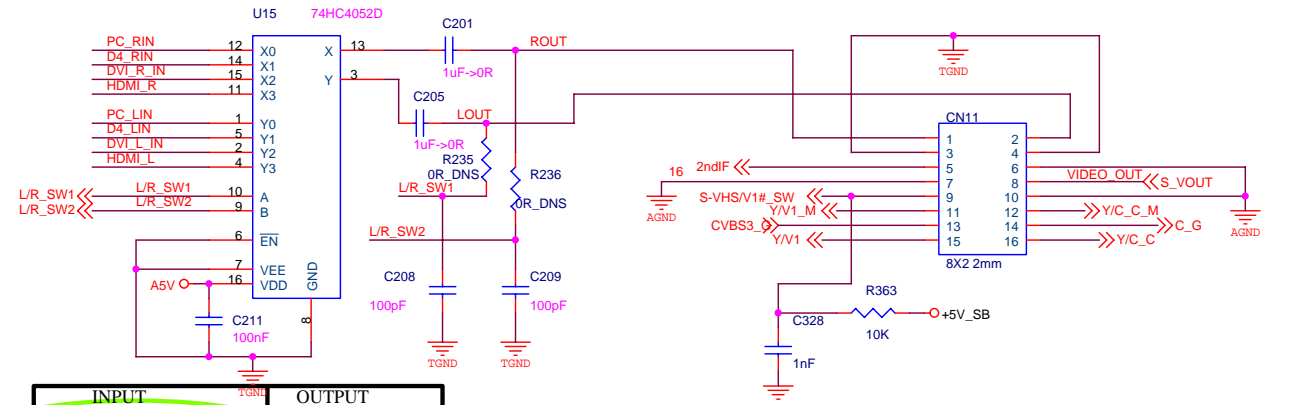
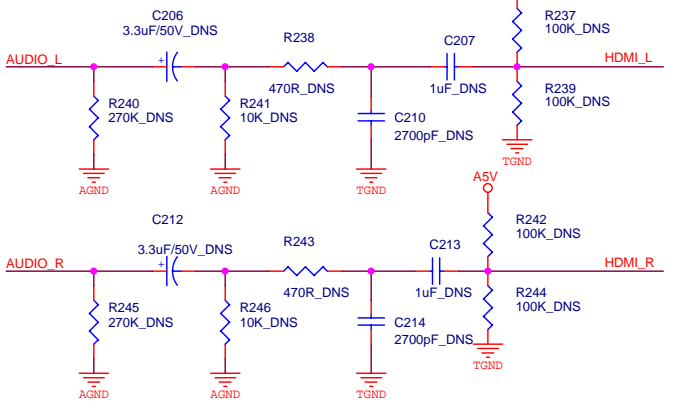
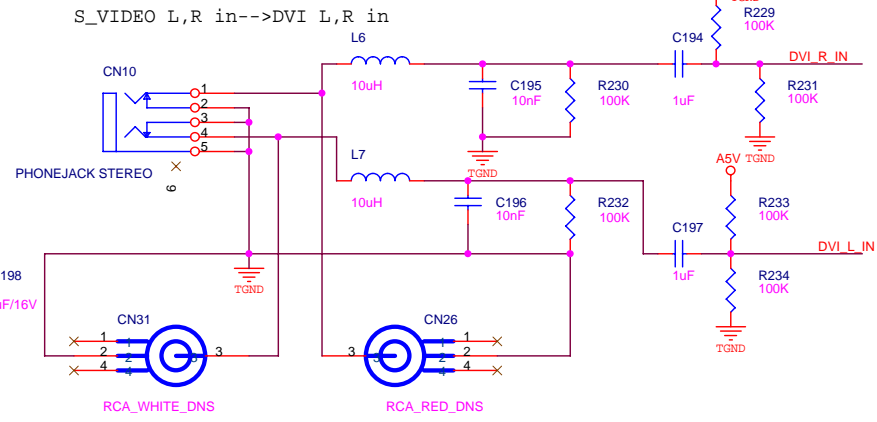
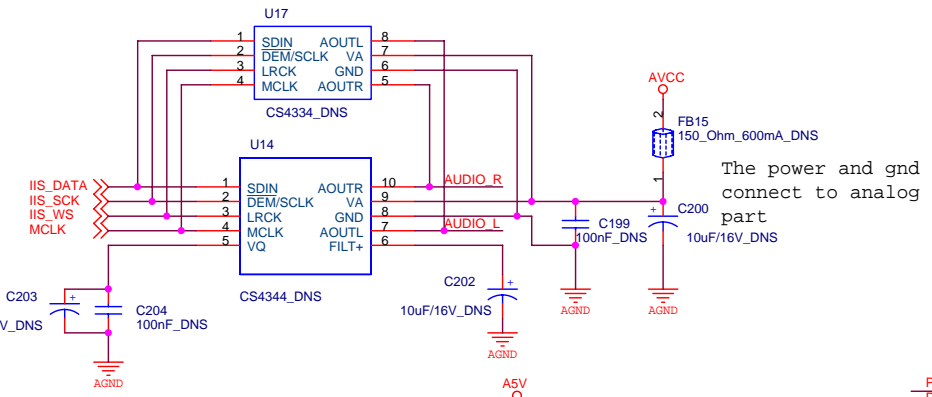
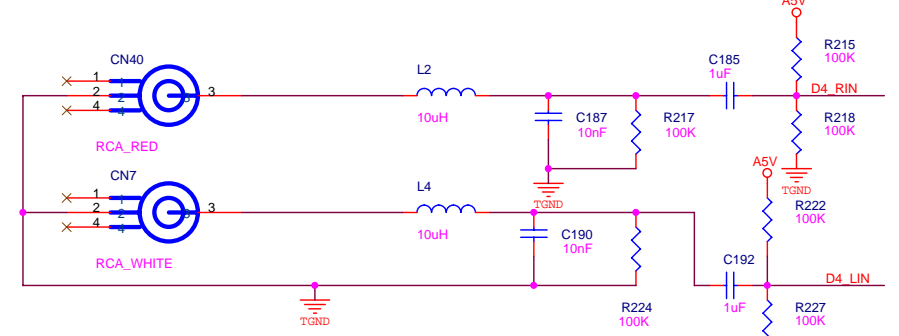
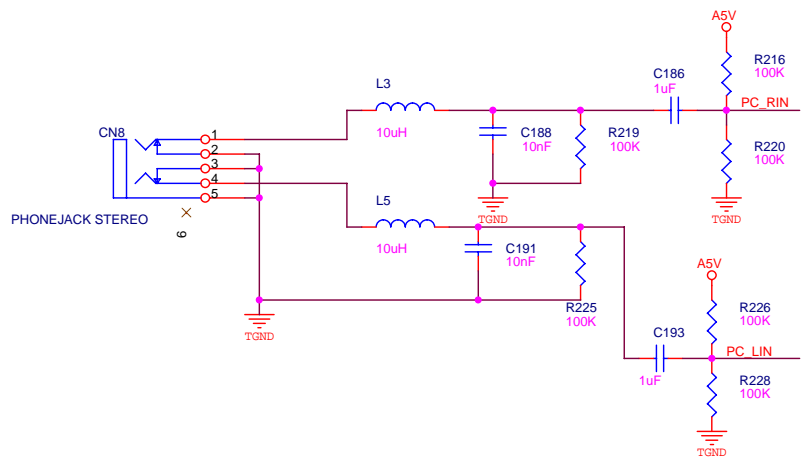

SW1 SW2 EXCHANGED

| INPUT   |         | OUTPUT     |
|---------|---------|------------|
| L/R_SW2 | L/R_SW1 | X,Y        |
| 0       | 0       | PC AUDIO   |
| 0       | 1       | YUV AUDIO  |
| 1       | 0       | DVI AUDIO  |
| 1       | 1       | HDMI AUDIO |

**Qingdao Haier Electronics Co., Ltd.**

Title: DVI-DAC&AUDIO INTERFACE

Size B | Document Number: 42PDP\_TV\_MAIN | Rev: C-03

Date: Saturday, February 18, 2006 | Sheet: 16 of 30

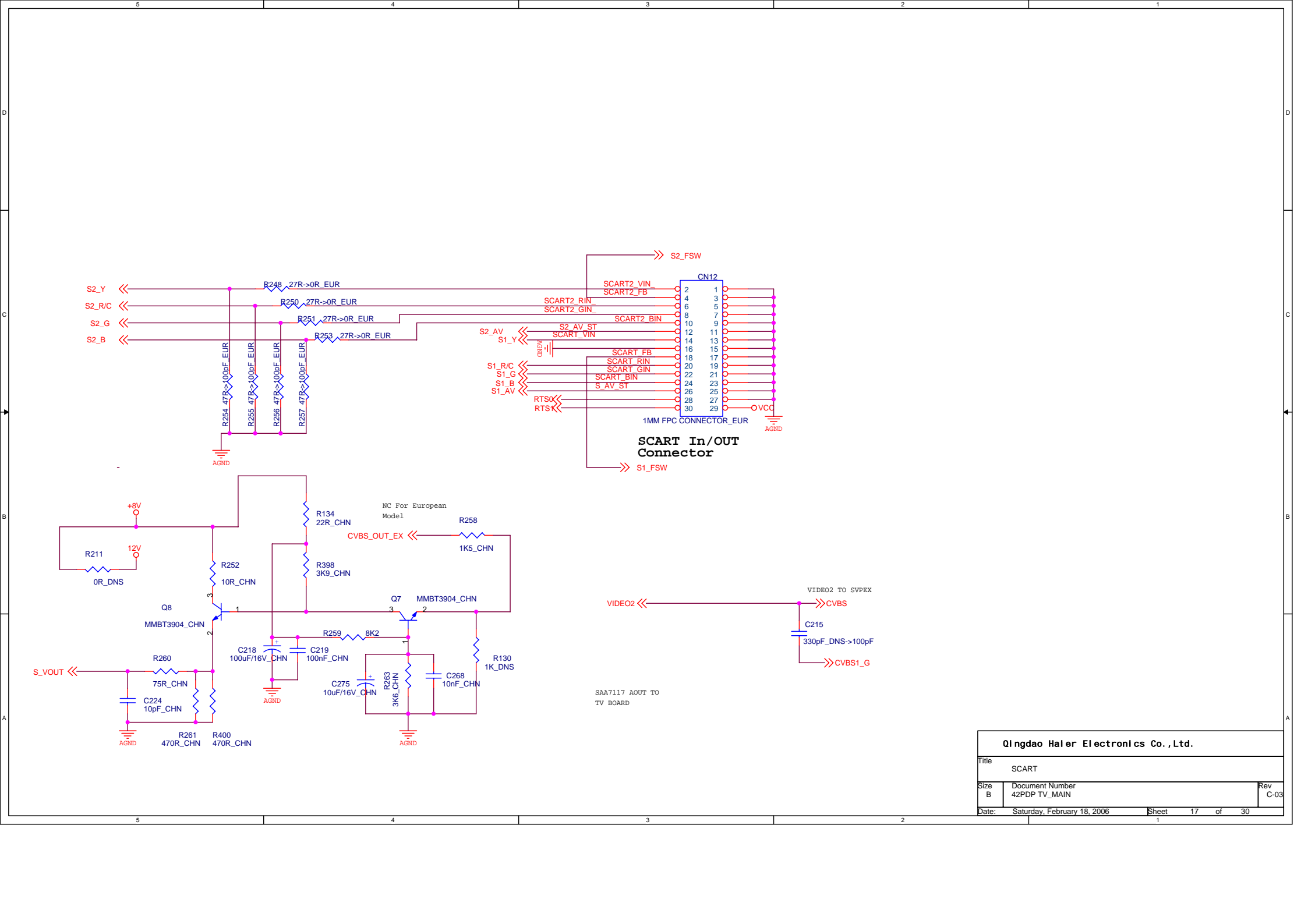

|                                     |                                  |                |
|-------------------------------------|----------------------------------|----------------|
| Qingdao Haier Electronics Co., Ltd. |                                  |                |
| Title<br>SCART                      |                                  |                |
| Size<br>B                           | Document Number<br>42PDP_TV_MAIN | Rev<br>C-03    |
| Date:                               | Saturday, February 18, 2006      | Sheet 17 of 30 |

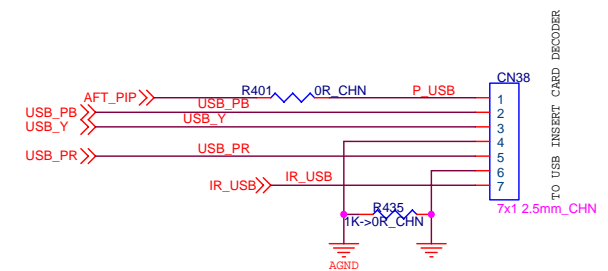
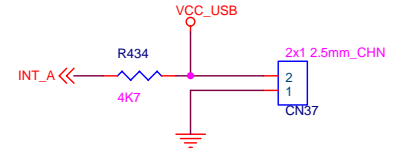
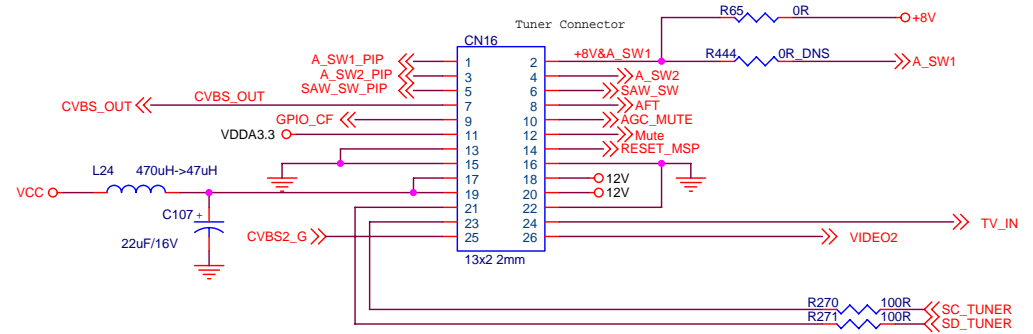
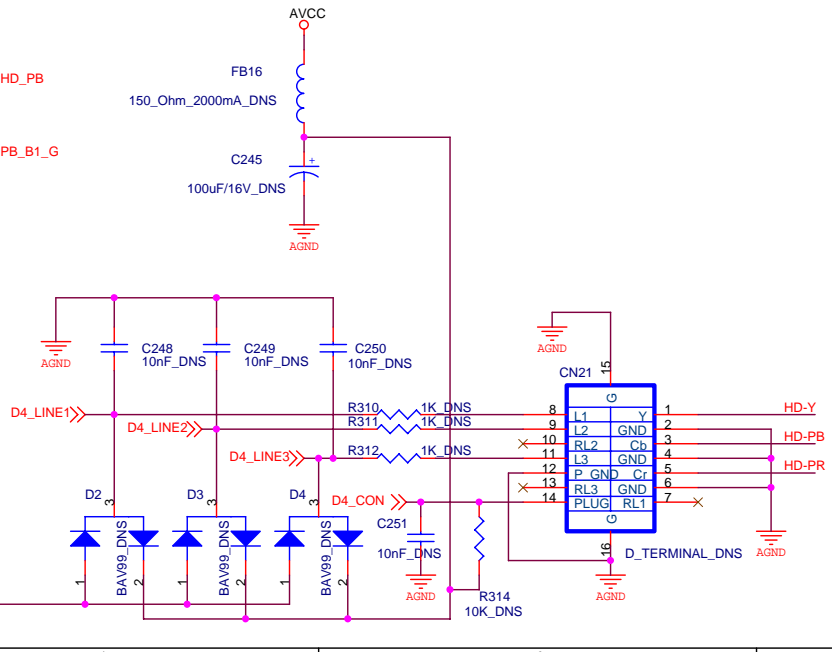
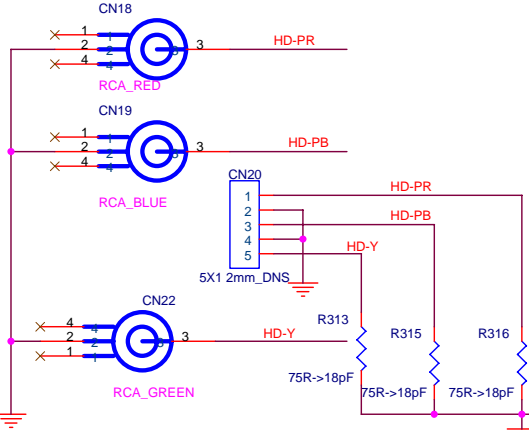
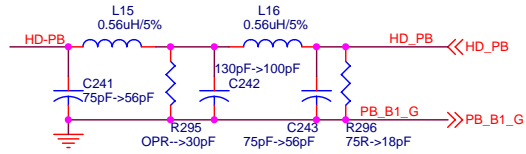
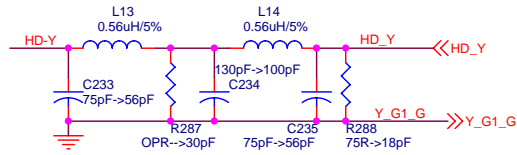
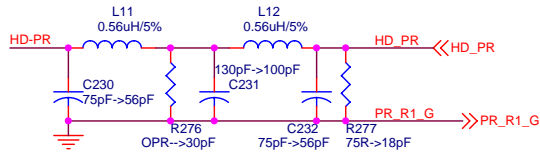

|                                     |                             |       |          |
|-------------------------------------|-----------------------------|-------|----------|
| Qingdao Haier Electronics Co., Ltd. |                             |       |          |
| Title                               | I/O_1                       |       | Rev      |
| Size                                | Document Number             | C-03  |          |
| B                                   | 42PDP_TV_MAIN               |       |          |
| Date:                               | Saturday, February 18, 2006 | Sheet | 18 of 30 |

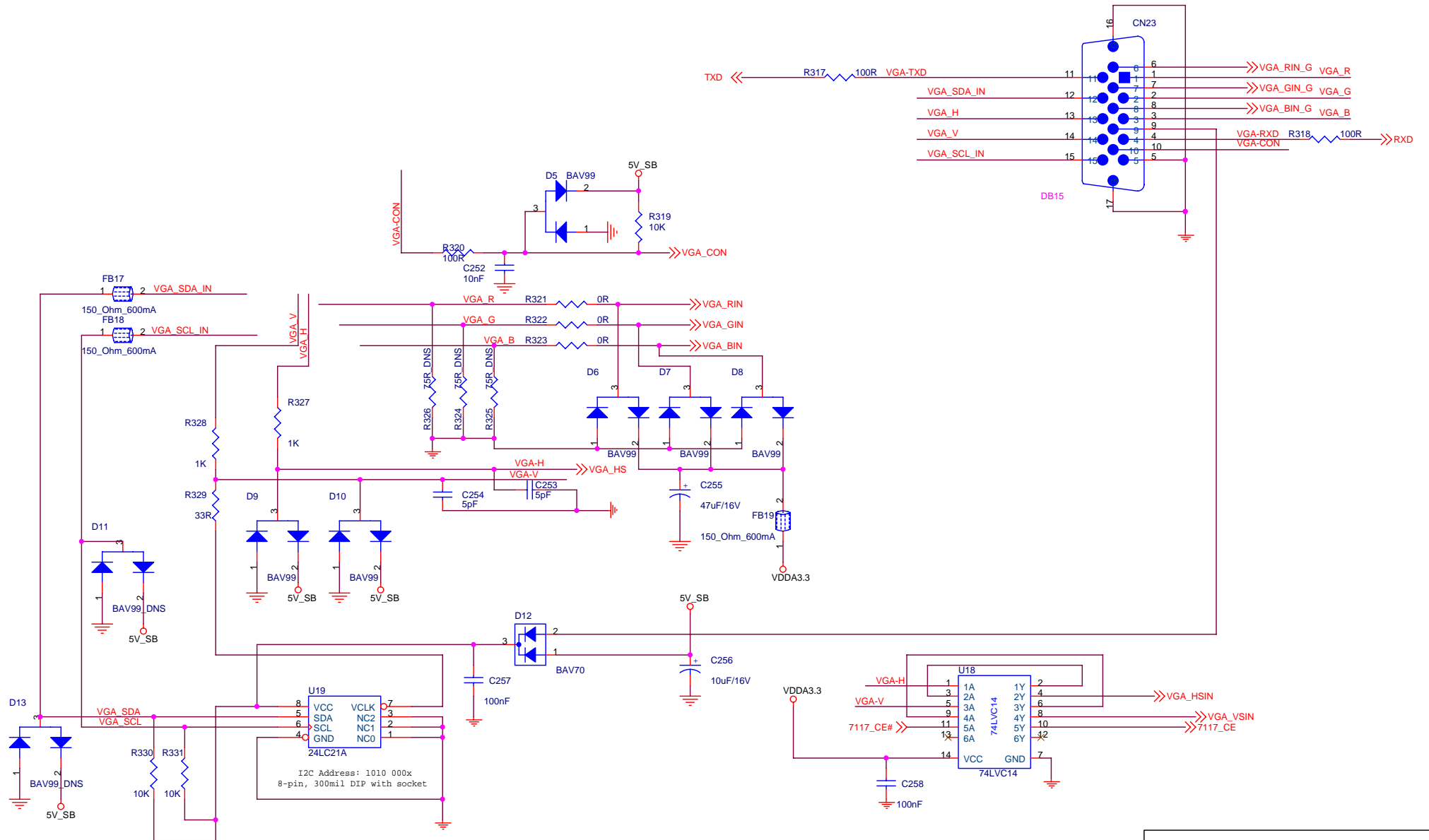

|  |                                |           |
|--|--------------------------------|-----------|
| <b>Qingdao Haier Electronics Co., Ltd.</b> |                                |           |
| Title: I/O_2                               |                                |           |
| Size: B                                    | Document Number: 42PDP_TV_MAIN | Rev: C-03 |
| Date: Saturday, February 18, 2006          | Sheet: 19                      | of 30     |

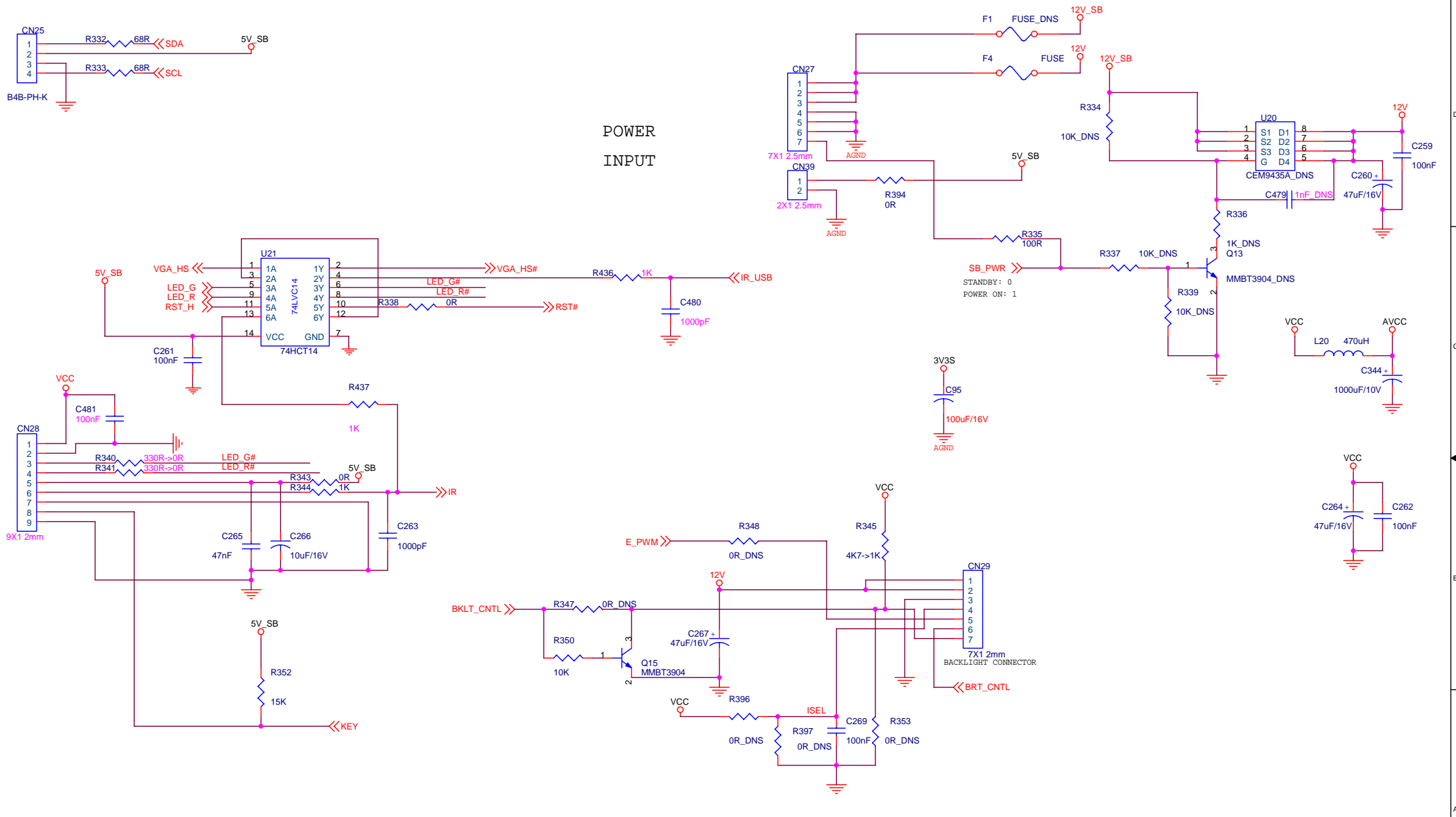

POWER INPUT

|                                     |                             |                |
|-------------------------------------|-----------------------------|----------------|
| Qingdao Haier Electronics Co., Ltd. |                             |                |
| Title                               | POWER INTERFACE             |                |
| Size                                | Document Number             | Rev            |
| B                                   | 42PDP_TV_MAIN               | C-03           |
| Date:                               | Saturday, February 18, 2006 | Sheet 20 of 30 |



### Power for DDR IO PADS

Linear equation:  
 $V_{out} = 1.25V * (1 + R354/R356)$   
 $R356, R361 = 110R \quad V_{OUT} = 2.5V$   
 $R356, R361 = 100R \quad V_{OUT} = 2.6V$   
 Linear condition:  
 $100ohm < (R356) < 200ohm$

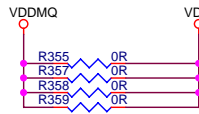

### Power for DDR Core Logic

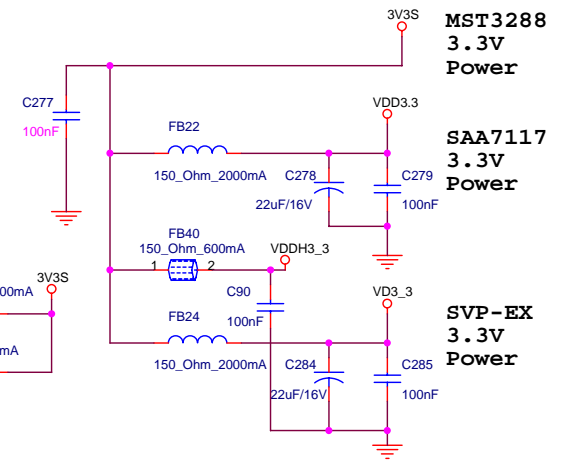
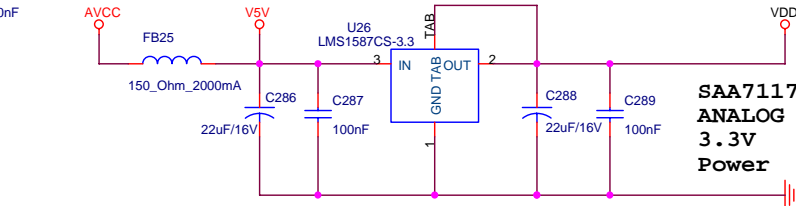
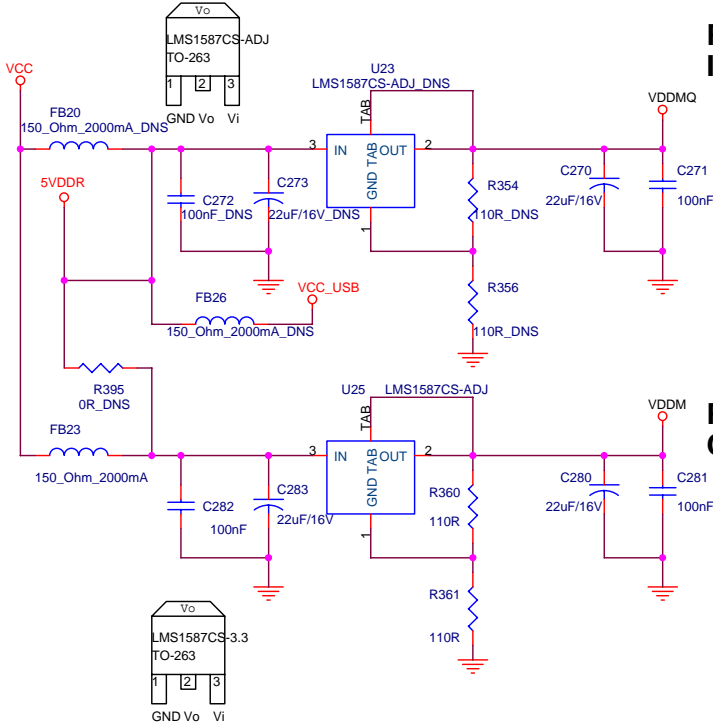

### SAA7117 XC2028 1.8V Power

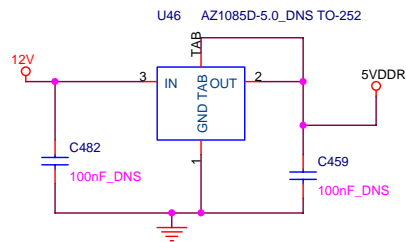
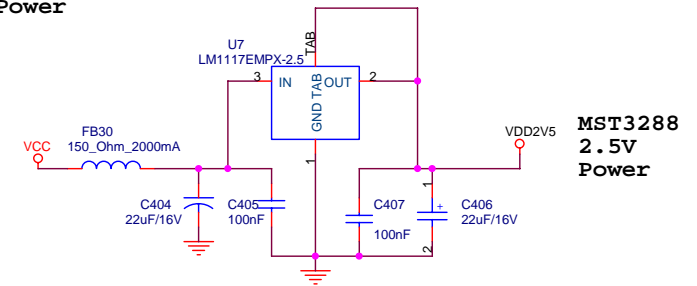
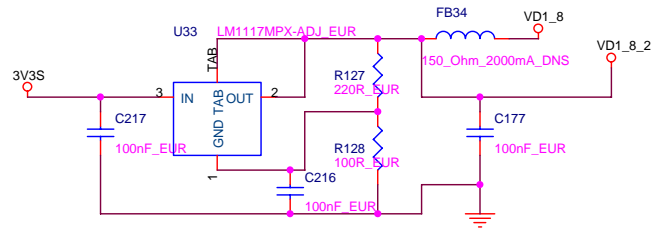

Qingdao Haler Electronics Co., Ltd.

|       |                             |       |       |    |      |
|-------|-----------------------------|-------|-------|----|------|
| Title |                             |       | POWER |    |      |
| Size  | Document Number             |       |       |    | Rev  |
| B     | 42PDP_TV_MAIN               |       |       |    | C-03 |
| Date: | Saturday, February 18, 2006 | Sheet | 21    | of | 30   |

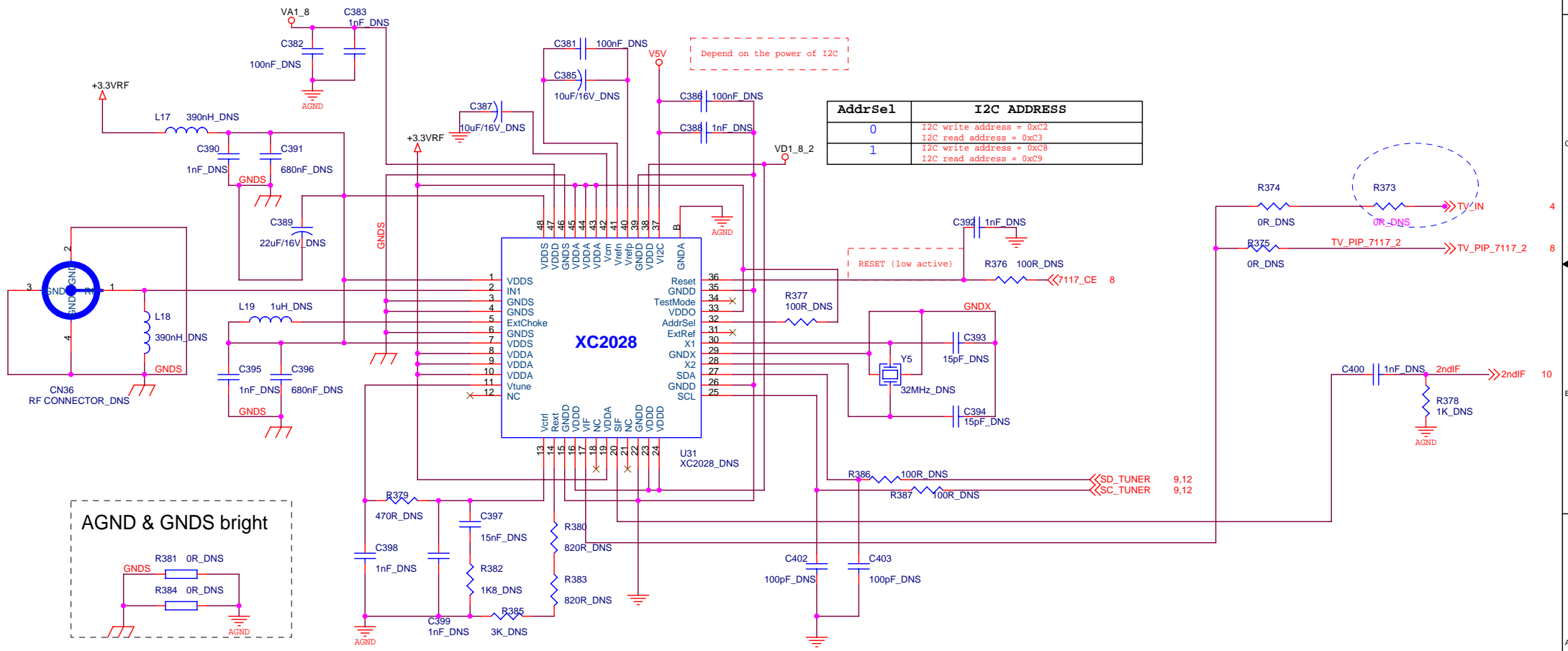
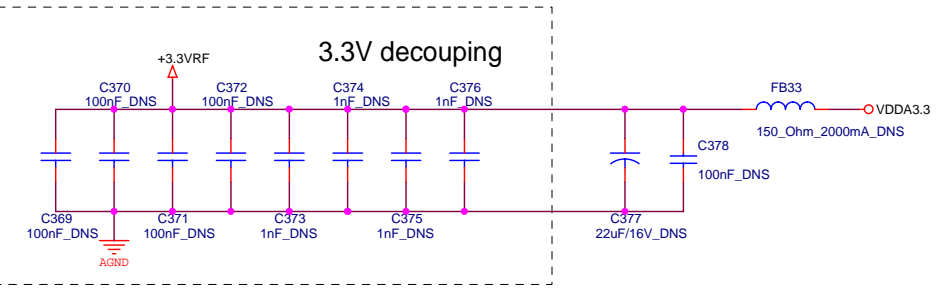
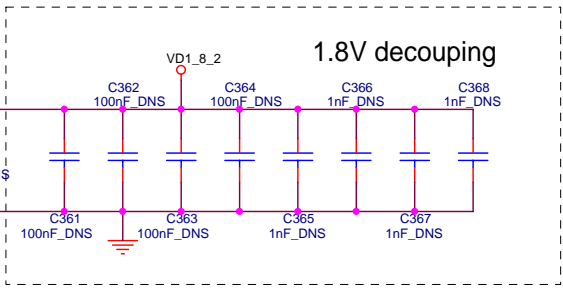

Depend on the power of I2C

| AddrSel | I2C ADDRESS   |
|---------|---|
| 0       | I2C write address = 0xC2<br>I2C read address = 0xC3 |
| 1       | I2C write address = 0xC8<br>I2C read address = 0xC9 |

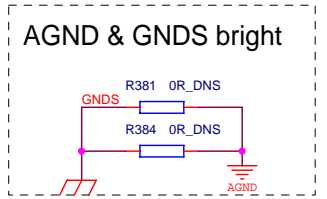

|                                     |                             |                |
|-------------------------------------|-----------------------------|----------------|
| Qingdao Haier Electronics Co., Ltd. |                             |                |
| Title                               | Tuner                       |                |
| Size                                | Document Number             | Rev            |
| B                                   | 42PDP_TV_MAIN               | C-03           |
| Date:                               | Saturday, February 18, 2006 | Sheet 22 of 30 |

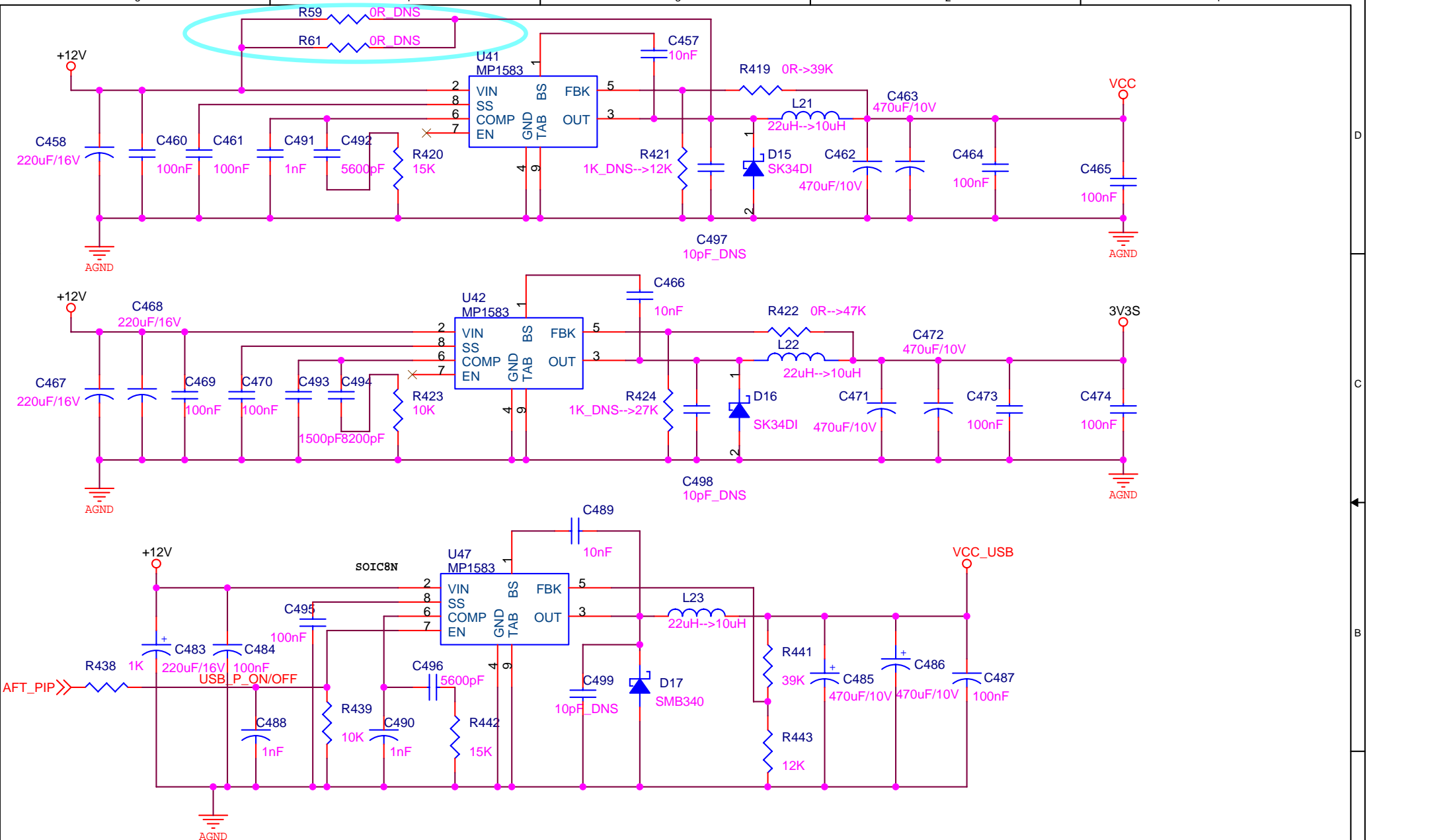

|  |                                  |                |
|--|----------------------------------|----------------|
| <b>Qingdao Haier Electronics Co., Ltd.</b> |                                  |                |
| Title<br>DC/DC POWER                       |                                  |                |
| Size<br>A                                  | Document Number<br>42PDP_TV_MAIN | Rev<br>C-03    |
| Date:                                      | Saturday, February 18, 2006      | Sheet 23 of 30 |

# REVISION HISTORY OF 42PDP\_TV\_AUDIO BOARDS

| REV   | DATE              | DESCRIPTION  | SIGNATURE |
|-------|-------------------|--|-----------|
| R 1.0 | Jan 13<br>2005    | DRAFT RELEASE  | Liuchy    |
| R 1.1 | Mar 21<br>2005    | <p>1.S/VIDEO1 TERMINALS MOVED FROM MAIN BOARD,SO CNA13 8PINS CHANGED TO 8X2PINS.</p> <p>2.DVI AUDIO TERMINALS MOVED TO MAIN BOARD.</p> <p>3.CNA3 3PINS CHANGED TO 5PINS,ADDED VIDEO INPUT FOR AV2 TERMINALS.</p> <p>4.CNA2 12X2PINS CHANGED TO 13X2PINS,ADDED VIDEO2 INPUT FOR AV2 TERMINALS.</p> <p>5.UA8 operational amplifiers changed from Voltage Followers to Inverting Amplifiers.</p>              | Liuchy    |
| R 1.2 | Jul 11<br>2005    | <p>1.ADDED CNA4 FOR +5V INPUT FROM PDP POWER SUPLAY.</p> <p>2.CA90,CA91,CA99,CA100 PCB FOOTPRINT CHANGED FROM 0603 TO 0805</p> <p>3.ADDED R202,R203,R204,R205</p> <p>4.CA71,CA74,CA80,CA81,CA82,CA83,CA84,CA107,CA112,CA138,CA139 PCB FOOTPRINT CHANGED FROM 0603 TO 0805</p> <p>5.ADDED +5V OUTPUT WITH SWITCH AND OVER CURRENT PROTECT CIRCUIT.</p> <p>6. TV AND VIDEO2 INPUT ADDED LOW PASS FILTER.</p> | Liuchy    |
| R 1.3 | Sep<br>27<br>2005 | <p>1. CNA4 6x1 2mm CHANGED TO 5x1 2.5mm.</p> <p>2. CNA11 2x1 2.5mm CHANGED TO 6x1 2mm.</p> <p>3. CA87 ADDED TO AXIAL LEAD PADS.</p> <p>4. CNA2 PIN2 CHANGED NET A_SW1 TO +8V.</p>  | Liuchy    |
| R 1.4 | Oct<br>19<br>2005 | <p>1.ADDED DA2,DA3,DA7,CA124,CA125.</p> <p>2.CA58,CA113,CA136,RA15,RA16,RA84 VALUE CHANGED.</p> <p>3.LA11 DELETED.</p>   | Liuchy    |
|       |                   |  |           |

|  |  |  |  |
|--|--|--|--|
|  |  |  |  |
|  |  |  |  |
|  |  |  |  |
|  |  |  |  |
|  |  |  |  |
|  |  |  |  |
|  |  |  |  |
|  |  |  |  |
|  |  |  |  |
|  |  |  |  |

|  |                             |       |          |
|--|-----------------------------|-------|----------|
| <b>Qingdao Haler Electronics Co., Ltd.</b> |                             |       |          |
| Title                                      |                             |       |          |
| Revision History                           |                             |       |          |
| Size                                       | Document Number             |       | Rev      |
| B  | 42PDP_TV_AUDIO              |       | 1.3      |
| Date:                                      | Saturday, February 18, 2006 | Sheet | 24 of 30 |

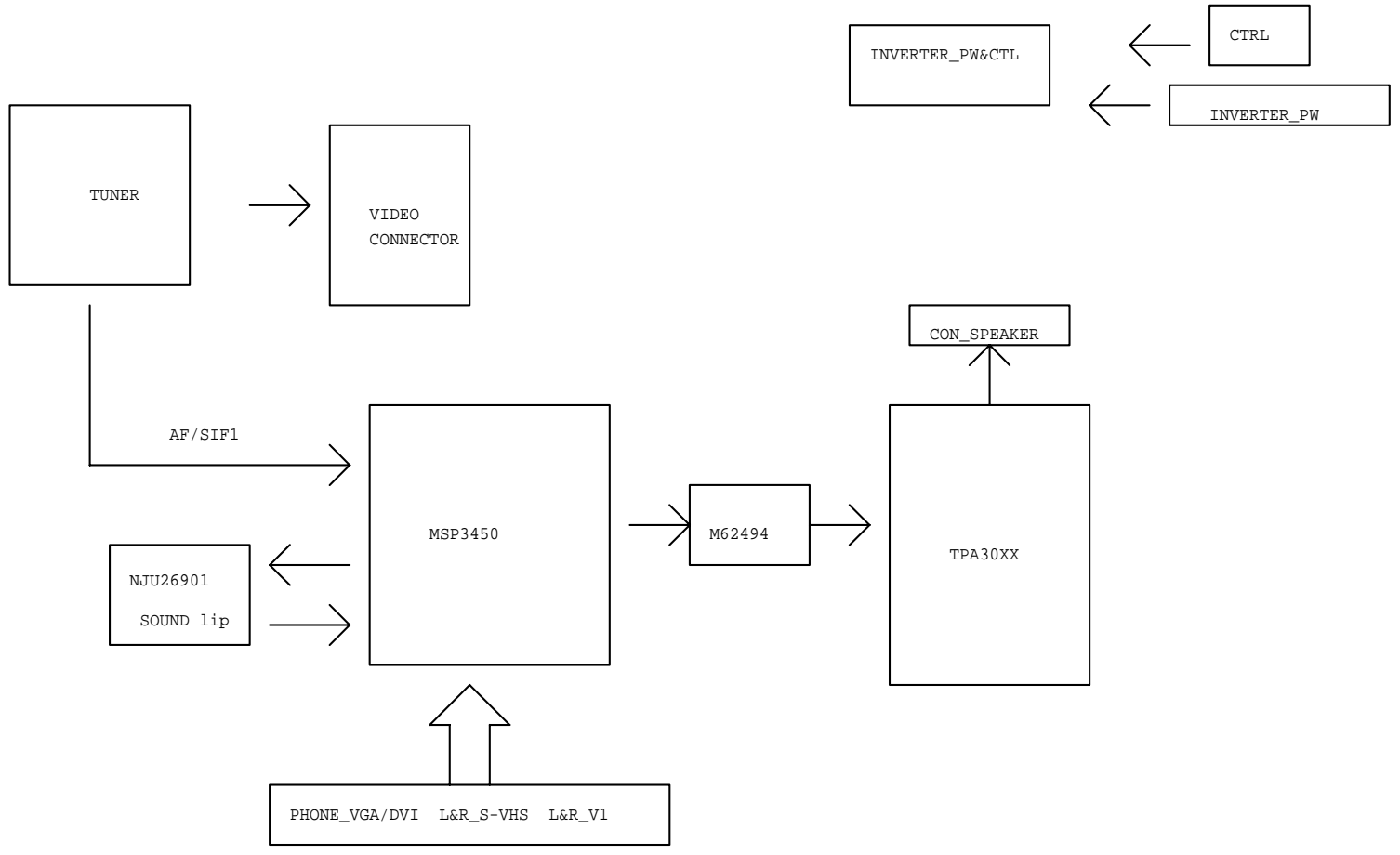

|  |                             |                |
|--|-----------------------------|----------------|
| <b>Qingdao Haier Electronics Co., Ltd.</b> |                             |                |
| Title                                      |                             |                |
| BLOCK                                      |                             |                |
| Size                                       | Document Number             | Rev            |
| A  | 42PDP_TV_AUDIO_CHN          | 1.3            |
| Date:                                      | Saturday, February 18, 2006 | Sheet 25 of 30 |

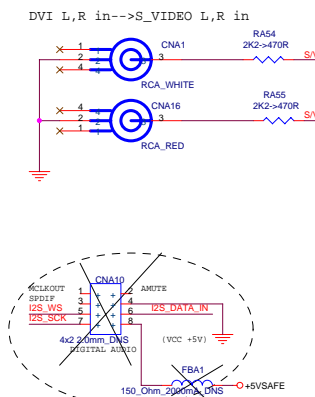
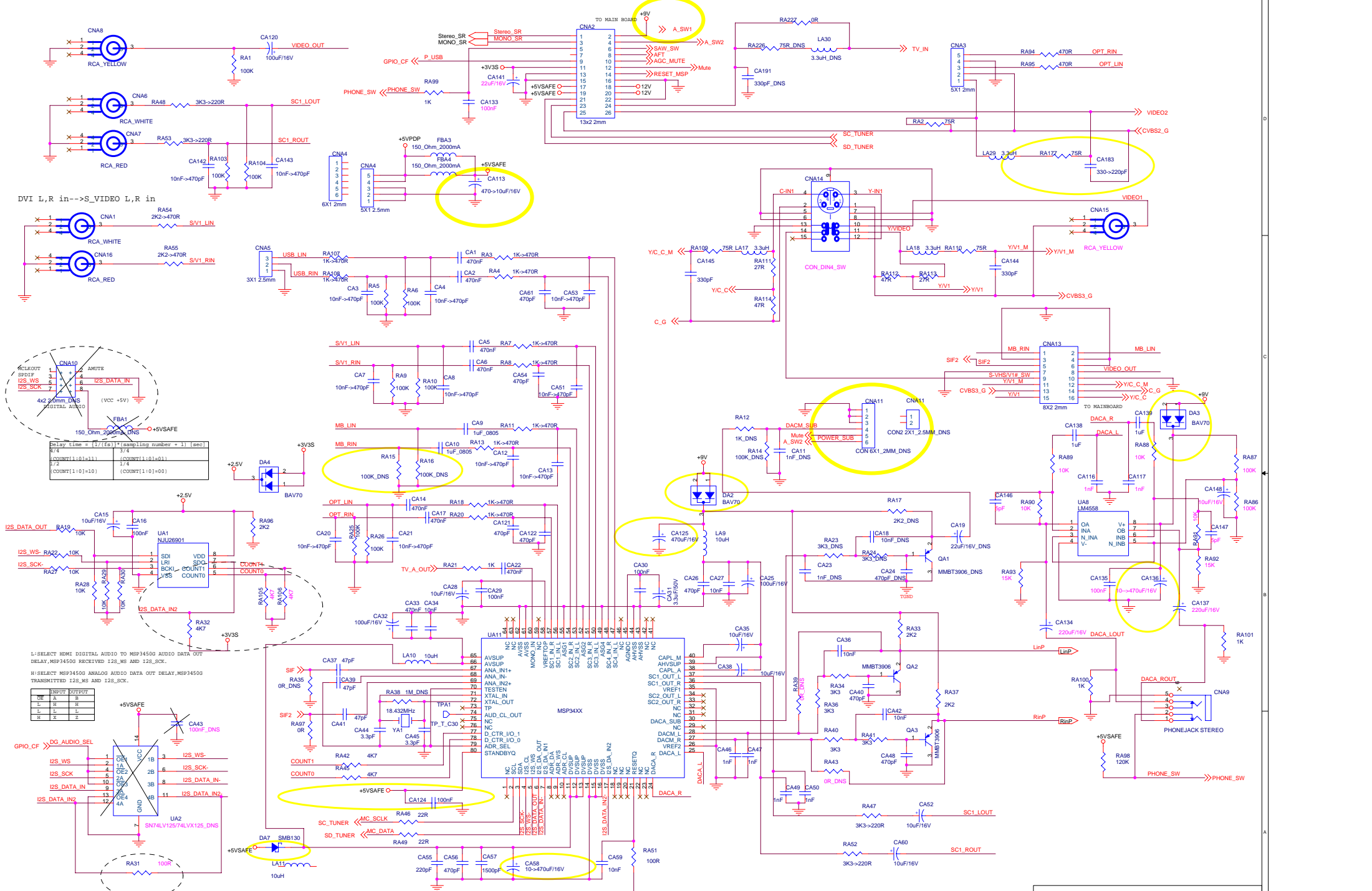

I-SELECT HDMI DIGITAL AUDIO TO MSP34500 AUDIO DATA OUT DELAY, MSP34500 RECEIVED I2S\_WS AND I2S\_SCK.  
 N-SELECT MSP34500 ANALOG AUDIO DATA OUT DELAY, MSP34500 TRANSMITTED I2S\_WS AND I2S\_SCK.

| INPUT | OUTPUT |
|-------|--------|
| OR    | A      |
| L     | B      |
| R     | C      |
| L     | D      |
| R     | E      |

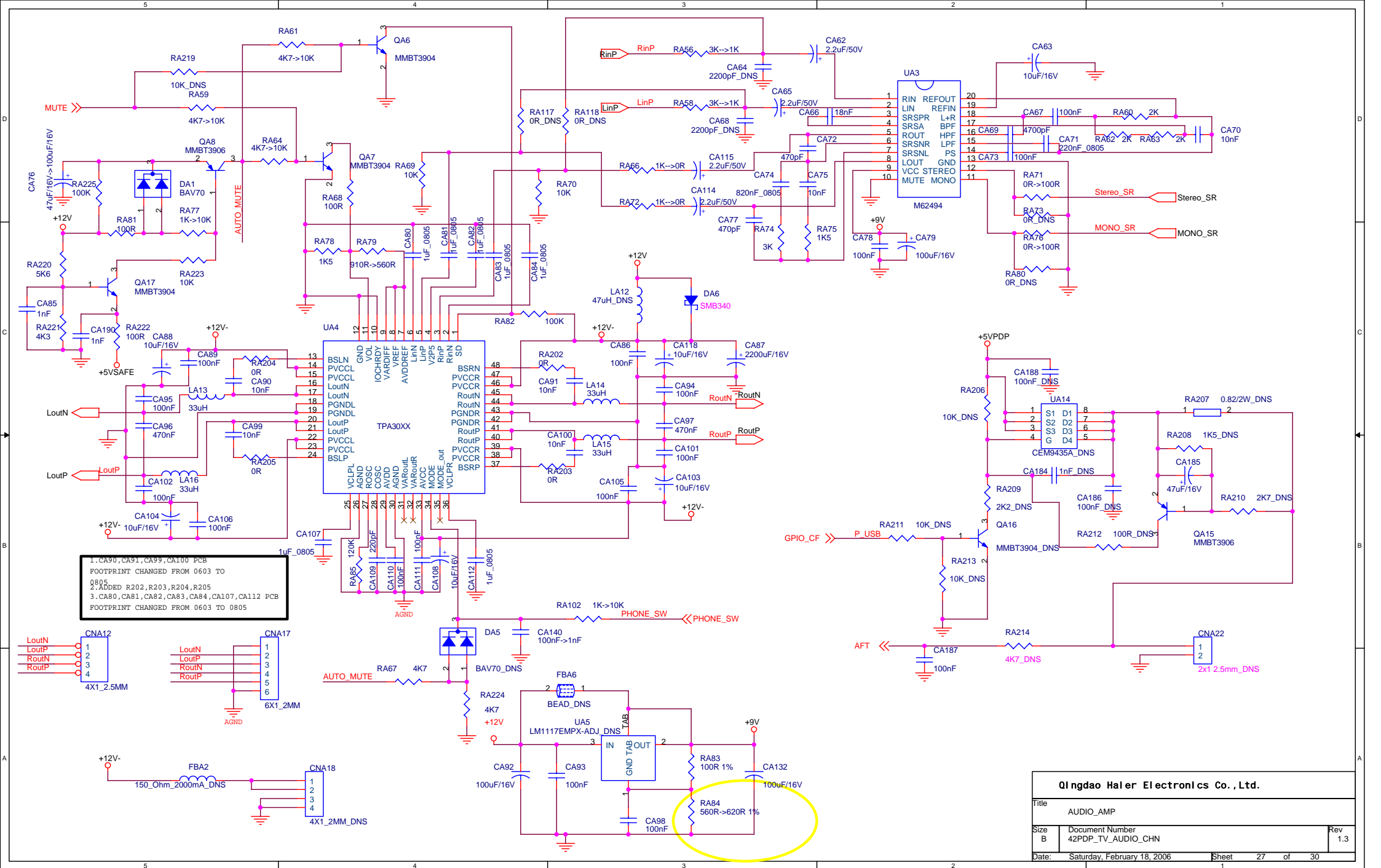

|                                     |                             |                |
|-------------------------------------|-----------------------------|----------------|
| Qingdao Haier Electronics Co., Ltd. |                             |                |
| Title                               | AUDIO_AMP                   |                |
| Size                                | Document Number             | Rev            |
| B                                   | 42PDP_TV_AUDIO_CHN          | 1.3            |
| Date:                               | Saturday, February 18, 2006 | Sheet 27 of 30 |

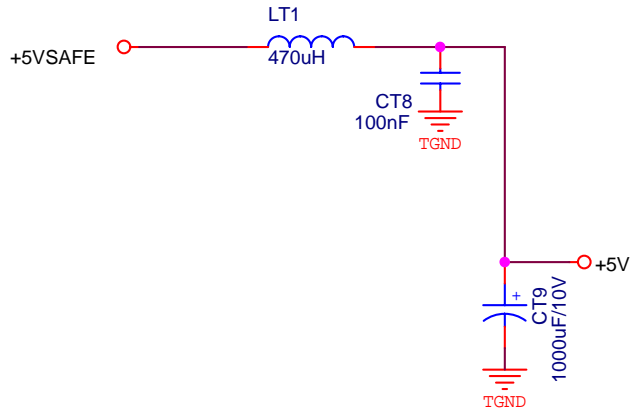
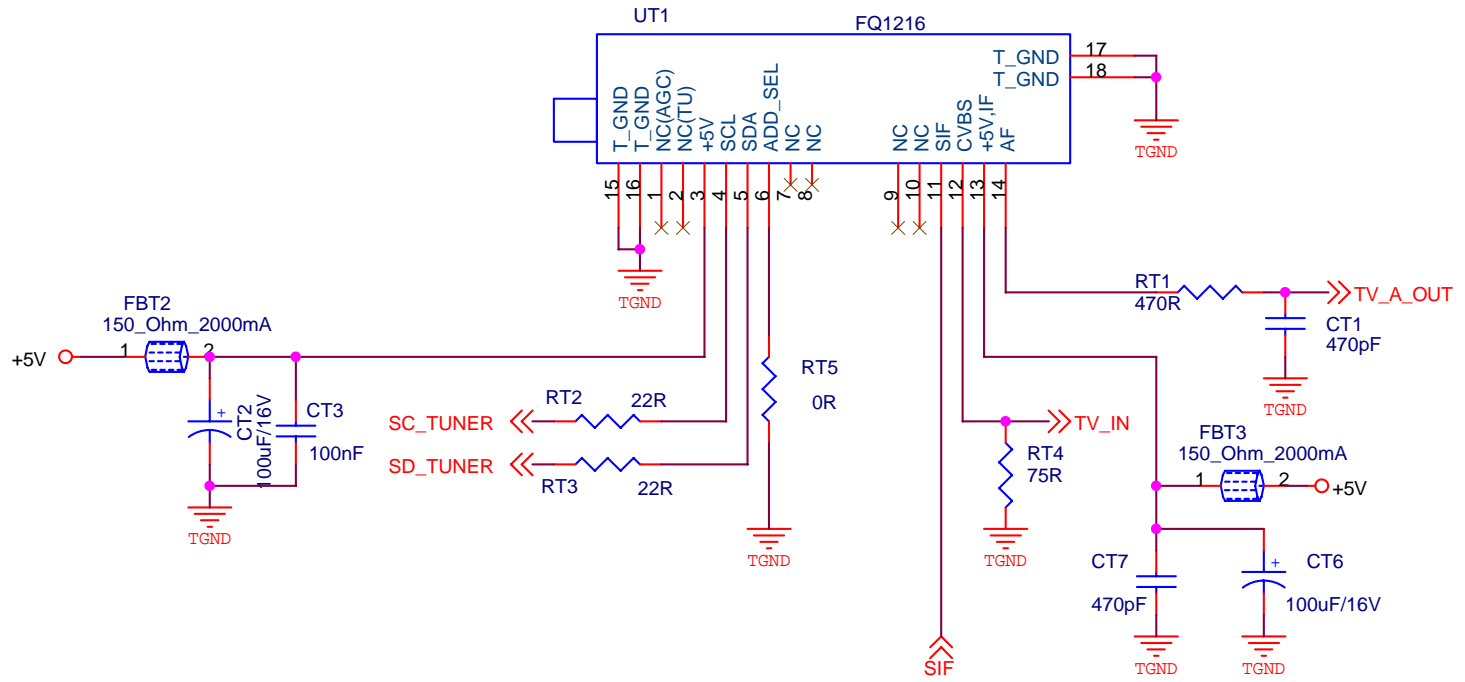
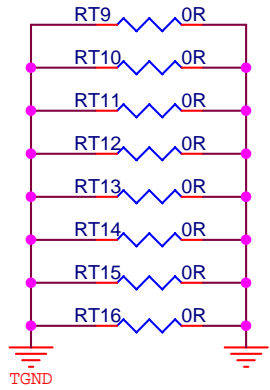

|  |                                       |            |
|--|---------------------------------------|------------|
| <b>Qingdao Haier Electronics Co., Ltd.</b> |                                       |            |
| Title<br>TUNER                             |                                       |            |
| Size<br>A                                  | Document Number<br>42PDP_TV_AUDIO_CHN | Rev<br>1.3 |
| Date:<br>Saturday, February 18, 2006       | Sheet<br>28                           | of 30      |



PH-4210X

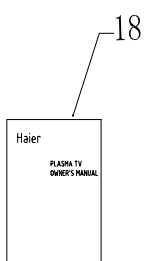
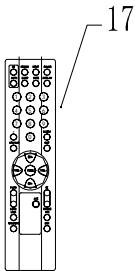
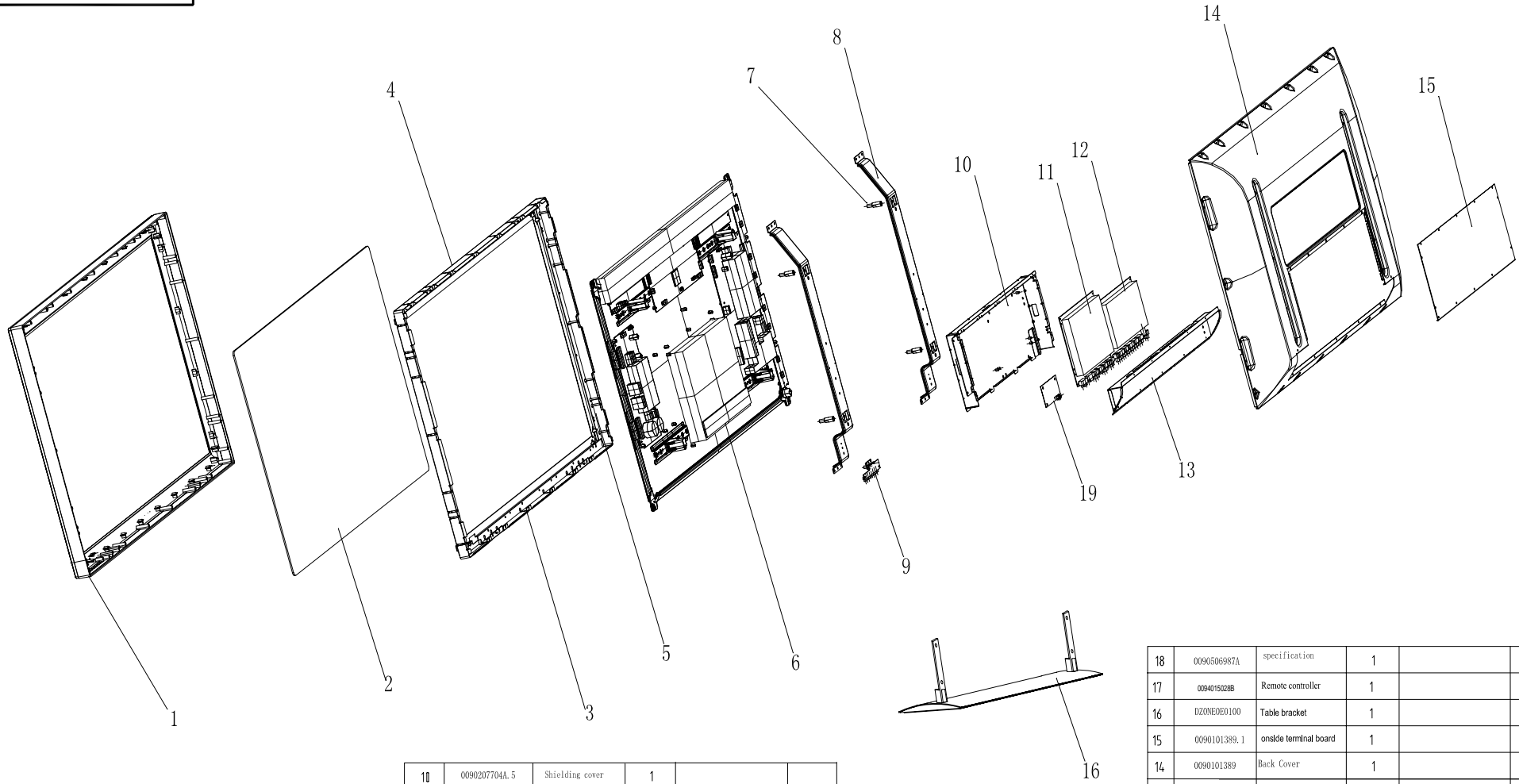

|        |               |                           |         |      |               |
|--------|---------------|---------------------------|---------|------|---------------|
| 10     | 0090207704A.5 | Shielding cover           | 1       |      |               |
| 9      | 0090701767    | Control panel subassembly | 1       |      |               |
| 8      | 0090207704A.6 | transition bracket        | 2       |      |               |
| 7      | 0090600278    | screw                     | 8       |      |               |
| 6      | 0094014444A   | 42 HD Module(LG)          | 1       |      |               |
| 5      | 0090207704A.4 | PRESS SLIP(Right Side)    | 1       |      |               |
| 4      | 0090207704A.1 | PRESS SLIP(Up Side)       | 1       |      |               |
| 3      | 0090207704A.2 | PRESS SLIP(Down Side)     | 1       |      |               |
| 2      | 0090300979    | Glass Filter              | 1       |      |               |
| 1      | 0090207704A   | Plastics front-frame      | 1       |      |               |
| Number | Material code | Name                      | Consume | Bolt | SPECIFICATION |

|        |               |                             |         |      |               |
|--------|---------------|-----------------------------|---------|------|---------------|
| 18     | 0090506987A   | specification               | 1       |      |               |
| 17     | 0094015028B   | Remote controller           | 1       |      |               |
| 16     | DZONE0E0100   | Table bracket               | 1       |      |               |
| 15     | 0090101389.1  | onside terminal board       | 1       |      |               |
| 14     | 0090101389    | Back Cover                  | 1       |      |               |
| 13     | 0090101390B   | Back terminal board         | 1       |      |               |
| 12     | 0090701098    | Emulation board subassembly | 1       |      |               |
| 11     | 009401466i    | Digital board subassembly   | 1       |      |               |
| Number | Material code | Name                        | Consume | Bolt | SPECIFICATION |

|            |         |                        |               |                                       |         |      |
|------------|---------|------------------------|---------------|---------------------------------------|---------|------|
| editor     | 06.4.24 | P42V6-A8KExploded view | W90JS-444---Q | 1st page                              | Total 1 |      |
| Auditing   | 06.4.24 |                        |               |                                       |         |      |
| normalizer | 06.4.24 |                        |               |                                       |         |      |
| authorize  | 06.4.24 |                        |               |                                       |         |      |
|            |         |                        | rejigger      | amount                                | sign    | Date |
|            |         |                        | Grade         | A Qingdao Haier Electronics Co., Ltd. |         |      |

DATE SIGN