

P4C164/P4C164L ULTRA HIGH SPEED 8K x 8 STATIC CMOS RAMS (SCRAMS)

T-46-23-12

★ FEATURES

- Full CMOS, 6T Cell
- High Speed (Equal Access and Cycle Times)
 - 12/15/20/25 ns (Commercial)
 - 20/25/35/45 ns (Military)
- Low Power Operation (Commercial/Military)
 - 770mW Active - 12,15
 - 660/743 mW Active - 20
 - 495/575 mW Active - 25, 35, 45
 - 193/220 mW Standby (TTL Input)
 - 5.5mW Standby (CMOS Input) P4C164L (Military)
- Output Enable and Dual Chip Enable Control Functions
- Single 5V±10% Power Supply
- Data Retention with 2.0V Supply, 10 µA Typical Current (P4C164L Military)
- Common Data I/O
- Fully TTL Compatible Inputs and Outputs
- Produced with PACE II Technology™
- Standard Pinout (JEDEC Approved)
 - 28-Pin 300 mil DIP, SOJ
 - 28-Pin 600 mil Ceramic DIP
 - 28-Pin 350 x 550 mil LCC

4

★ DESCRIPTION

The P4C164 and P4C164L are 65,536-bit ultra high-speed static RAMs organized as 8K x 8. The CMOS memories require no clocks or refreshing and have equal access and cycle times. Inputs are fully TTL-compatible. The RAMs operate from a single 5V±10% tolerance power supply. With battery backup, data integrity is maintained with supply voltages down to 2.0V. Current drain is typically 10 µA from a 2.0V supply.

CMOS inputs, power consumption is only 5.5 mW for the P4C164L. The P4C164 and P4C164L are members of a family of PACE RAM™ products offering super fast access times never before available at these complexity levels in TTL-compatible bipolar or CMOS technologies. The P4C164 and P4C164L are manufactured with PACE II Technology.

Access times as fast as 12 nanoseconds are available, permitting greatly enhanced system operating speeds. CMOS is used to reduce power consumption to a low 770 mW active, 193 mW standby. In full standby mode with

The P4C164 and P4C164L are available in 28-pin 300 mil DIP and SOJ, 28-pin 600 mil ceramic DIP, and 28-pin 350 x 550 mil LCC packages providing excellent board level densities.

FUNCTIONAL BLOCK DIAGRAM

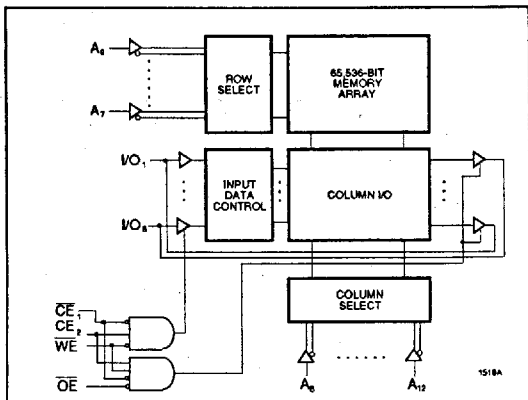

PIN CONFIGURATIONS

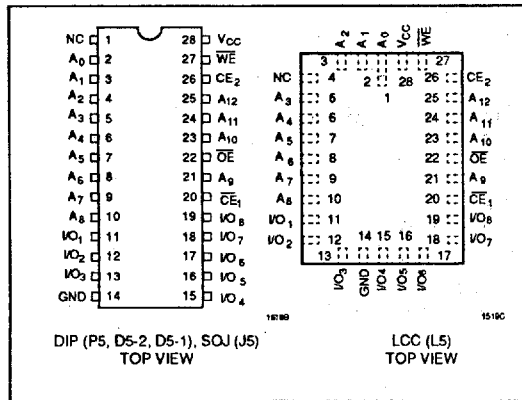

Means Quality, Service and Speed

©1992 Performance Semiconductor Corporation

P4C164/164L

MAXIMUM RATINGS⁽¹⁾

T-46-23-12

Symbol	Parameter	Value	Unit
V _{CC}	Power Supply Pin with Respect to GND	-0.5 to +7	V
V _{TERM}	Terminal Voltage with Respect to GND (up to 7.0V)	-0.5 to V _{CC} +0.5	V
T _A	Operating Temperature	-55 to +125	°C

1519 01

Symbol	Parameter	Value	Unit
T _{BIAS}	Temperature Under Bias	-55 to +125	°C
T _{STG}	Storage Temperature	-65 to +150	°C
P _T	Power Dissipation	1.0	W
I _{OUT}	DC Output Current	50	mA

1519 02

RECOMMENDED OPERATING TEMPERATURE AND SUPPLY VOLTAGE

Grade ⁽²⁾	Ambient Temperature	GND	V _{CC}
Military	-55 to +125°C	0V	5.0V ± 10%

1519 03

Grade ⁽²⁾	Ambient Temperature	GND	V _{CC}
Commercial	0°C to +70°C	0V	5.0V ± 10%

1519 04

DC ELECTRICAL CHARACTERISTICS

Over recommended operating temperature and supply voltage⁽²⁾

Symbol	Parameter	Test Conditions	P4C164		P4C164L		Unit	
			Min	Max	Min	Max		
V _{IH}	Input High Voltage		2.2	V _{CC} +0.5	2.2	V _{CC} +0.5	V	
V _{IL}	Input Low Voltage		-0.5 ⁽³⁾	0.8	-0.5 ⁽³⁾	0.8	V	
V _{HC}	CMOS Input High Voltage		V _{CC} -0.2	V _{CC} +0.5	V _{CC} -0.2	V _{CC} +0.5	V	
V _{LC}	CMOS Input Low Voltage		-0.5 ⁽³⁾	0.2	-0.5 ⁽³⁾	0.2	V	
V _{CD}	Input Clamp Diode Voltage	V _{CC} = Min., I _{IN} = -18 mA		-1.2		-1.2	V	
V _{OL}	Output Low Voltage (TTL Load)	I _{OL} = +8 mA, V _{CC} = Min.		0.4		0.4	V	
V _{OH}	Output High Voltage (TTL Load)	I _{OH} = -4 mA, V _{CC} = Min.	2.4		2.4		V	
I _{LI}	Input Leakage Current	V _{CC} = Max. V _{IN} = GND to V _{CC}	Mil. Com'l.	-10 +5	+10 +5	-5 n/a	+5 n/a	µA
I _{LO}	Output Leakage Current	V _{CC} = Max., CE = V _{IH} V _{OUT} = GND to V _{CC}	Mil. Com'l.	-10 -5	+10 +5	-5 n/a	+5 n/a	µA

1519 05

CAPACITANCES⁽⁴⁾

(V_{CC} = 5.0V, T_A = 25°C, f = 1.0MHz)

Symbol	Parameter	Conditions	Typ.	Unit
C _{IN}	Input Capacitance	V _{IN} = 0V	5	pF

1519 06

Symbol	Parameter	Conditions	Typ.	Unit
C _{OUT}	Output Capacitance	V _{OUT} = 0V	7	pF

1519 07

Notes:

- Stresses greater than those listed under MAXIMUM RATINGS may cause permanent damage to the device. This is a stress rating only and functional operation of the device at these or any other conditions above those indicated in the operational sections of this specification is not implied. Exposure to MAXIMUM rating conditions for extended periods may affect reliability.
- Extended temperature operation guaranteed with 400 linear feet per minute of air flow.
- Transient inputs with V_{IL} and I_{IL} not more negative than -3.0V and -100mA, respectively, are permissible for pulse widths up to 20 ns.
- This parameter is sampled and not 100% tested.

POWER DISSIPATION CHARACTERISTICS

T-46-23-12

Over recommended operating temperature and supply voltage⁽²⁾

Symbol	Parameter	Test Conditions	P4C164		P4C164L		Unit
			Min	Max	Min	Max	
I_{CC}	Dynamic Operating Current - 12,15	$V_{CC} = \text{Max.}, f = \text{Max.},$ Outputs Open	Mil. Com'l.	— 140	n/a 140	— n/a	mA
I_{CC}	Dynamic Operating Current - 20	$V_{CC} = \text{Max.}, f = \text{Max.},$ Outputs Open	Mil. Com'l.	— 135	— 120	— 135	n/a
I_{CC}	Dynamic Operating Current - 25, 35, 45	$V_{CC} = \text{Max.}, f = \text{Max.},$ Outputs Open	Mil. Com'l.	— 105	— 90	— 105	n/a
I_{SB}	Standby Power Supply Current (TTL Input Levels) - 20, 25, 35, 45	$\overline{CE}_1 \geq V_{IH}$ or $\overline{CE}_2 \leq V_{IL}, V_{CC} = \text{Max.},$ $f = \text{Max.},$ Outputs Open	Mil. Com'l.	— 40	— 35	— 40	n/a
I_{SB}	Standby Power Supply Current (TTL Input Levels) - 12, 15	$\overline{CE}_1 \geq V_{IH}$ or $\overline{CE}_2 \leq V_{IL}, V_{CC} = \text{Max.},$ $f = \text{Max.},$ Outputs Open	Mil. Com'l.	— 45	—	— n/a	n/a
I_{SB1}	Standby Power Supply Current (CMOS Input Levels)	$\overline{CE}_1 \geq V_{HC}$ or $\overline{CE}_2 \leq V_{LC}, V_{CC} = \text{Max.},$ $f = 0,$ Outputs Open, $V_{IN} \leq V_{LC}$ or $V_{IN} \geq V_{HC}$	Mil. Com'l.	— 25	— 23	— 1	n/a

n/a = Not Applicable

1519 08

4

DATA RETENTION CHARACTERISTICS (P4C164L, Military Temperature Only)

Symbol	Parameter	Test Condition	Min	Typ.* $V_{CC} =$		Max $V_{CC} =$		Unit
				2.0V	3.0V	2.0V	3.0V	
V_{DR}	V_{CC} for Data Retention		2.0					V
I_{CCDR}	Data Retention Current	$\overline{CE}_1 \geq V_{CC} - 0.2V$ or $\overline{CE}_2 \leq 0.2V, V_{IN} \geq V_{CC} - 0.2V$ or $V_{IN} \leq 0.2V$		10	15	200	300	μA
t_{CDR}	Chip Deselect to Data Retention Time		0					ns
t_R^\dagger	Operation Recovery Time		t_{RC}^\S					ns

* $T_A = +25^\circ C$

$t_{RC}^\S =$ Read Cycle Time

† This parameter is guaranteed but not tested.

1519 09

DATA RETENTION WAVEFORM

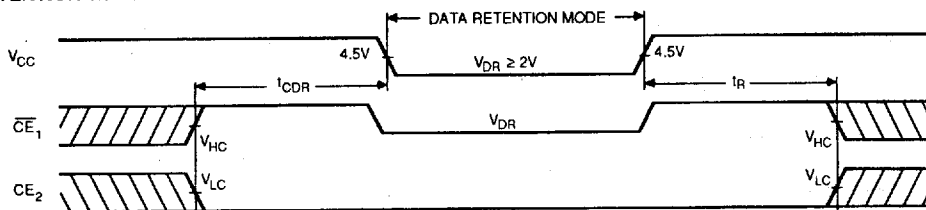

1519 01

AC ELECTRICAL CHARACTERISTICS—READ CYCLE

T-46-23-12

(V_{CC} = 5V ± 10%, All Temperature Ranges)⁽²⁾

Sym.	Parameter	-12*		-15		-20		-25		-35		-45		Unit
		Min	Max	Min	Max	Min	Max	Min	Max	Min	Max	Min	Max	
t _{RC}	Read Cycle Time	12	12	15	15	20	20	25	25	35	35	45	45	ns
t _{AA}	Address Access Time		12		15		20		25		35		45	ns
t _{AC}	Chip Enable Access Time		12		15		20		25		35		45	ns
t _{OH}	Output Hold from Address Change	2		2		2		3		3		3		ns
t _{LZ}	Chip Enable to Output in Low Z	2		2		2		3		3		3		ns
t _{HZ}	Chip Disable to Output in High Z		7		8		8		10		15		20	ns
t _{OE}	Output Enable Low to Data Valid		7		9		10		13		18		20	ns
t _{OLZ}	Output Enable Low to Low Z	2		2		2		3		3		3		ns
t _{OHZ}	Output Enable High to High Z		7		9		9		12		15		20	ns
t _{PU}	Chip Enable to Power Up Time	0		0		0		0		0		0		ns
t _{PD}	Chip Disable to Power Down Time		12		15		20		20		20		25	ns

■ Advance Information
 * V_{CC} = 5V ± 5%

1519 02

READ CYCLE NO. 1 (\overline{OE} CONTROLLED)⁽⁶⁾

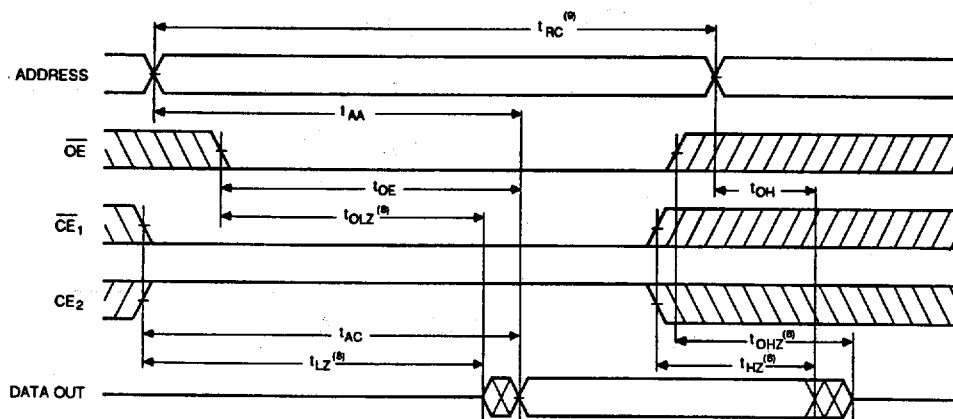

Notes:

- WE is HIGH for READ cycle.
- CE₁ is LOW, CE₂ is HIGH and \overline{OE} is LOW for READ cycle.
- ADDRESS must be valid prior to, or coincident with CE₁ transition LOW and CE₂ transition HIGH.

- Transition is measured ± 200 mV from steady state voltage prior to change, with loading as specified in Figure 1. This parameter is sampled and not 100% tested.

T-46-23-12

READ CYCLE NO. 2 (ADDRESS CONTROLLED) (6,9)

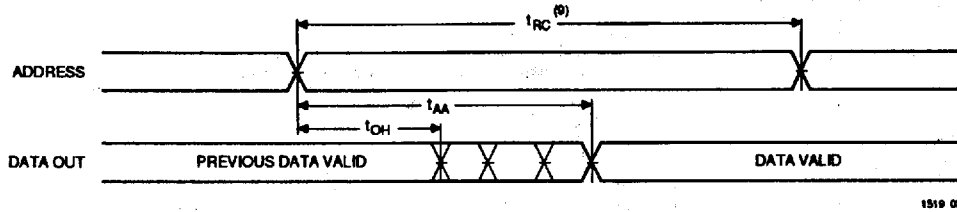

1519 03

READ CYCLE NO. 3 (\overline{CE}_1 , CE_2 CONTROLLED) (6,7,10)

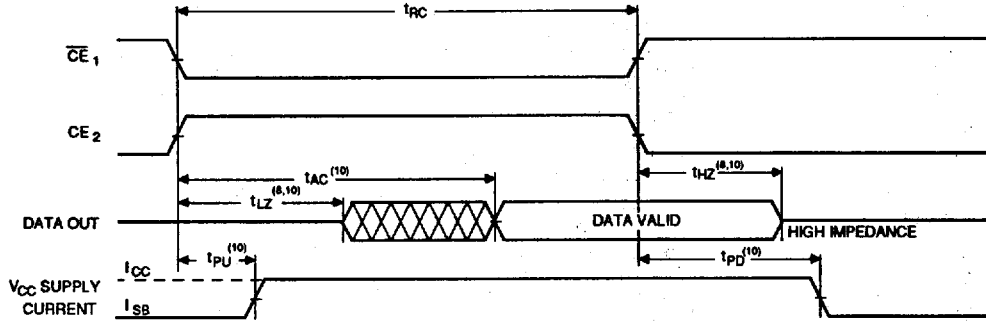

1519 04

Notes:

9. READ Cycle Time is measured from the last valid address to the first transitioning address.

10. Transitions caused by a chip enable control have similar delays irrespective of whether \overline{CE}_1 or CE_2 causes them.

4



AC CHARACTERISTICS—WRITE CYCLE

T-46-23-12

(V_{CC} = 5V ± 10%, All Temperature Ranges)⁽²⁾

Sym.	Parameter	-12*		-15		-20		-25		-35		-45		Unit
		Min	Max	Min	Max	Min	Max	Min	Max	Min	Max	Min	Max	
t _{WC}	Write Cycle Time	12		15		20		25		35		45		ns
t _{CW}	Chip Enable Time to End of Write	5		12		15		18		25		33		ns
t _{AW}	Address Valid to End of Write	10		12		15		18		25		33		ns
t _{AS}	Address Set-up Time	0		0		0		0		0		0		ns
t _{WP}	Write Pulse Width	9		12		15		18		20		25		ns
t _{AH}	Address Hold Time	0		0		0		0		0		0		ns
t _{DW}	Data Valid to End of Write	7		9		11		13		15		20		ns
t _{DH}	Data Hold Time	0		0		0		0		0		0		ns
t _{WZ}	Write Enable to Output in High Z		7		7		8		10		14		18	ns
t _{OW}	Output Active from End of Write	3		3		3		3		5		5		ns

■ Advance Information

* V_{CC} = 5V ± 5%

1519 11

WRITE CYCLE NO. 1 (WE CONTROLLED)⁽¹¹⁾

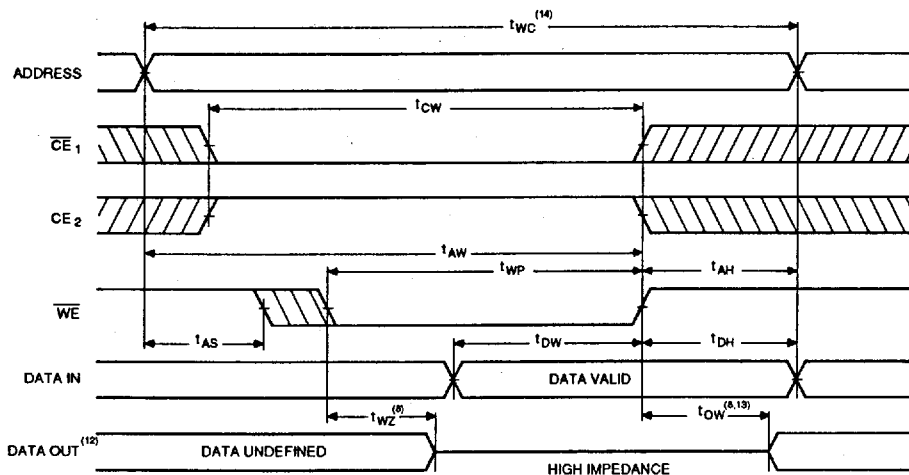

1519 05

Notes:

11. CE₁ and WE must be LOW, and CE₂ HIGH for WRITE cycle.

12. OE is LOW for this WRITE cycle to show t_{WZ} and t_{OW}.

13. If CE₁ goes HIGH, or CE₂ goes LOW, simultaneously with WE HIGH, the output remains in a high impedance state.

14. Write Cycle Time is measured from the last valid address to the first transitioning address.

TIMING WAVEFORM OF WRITE CYCLE NO. 2 (CE CONTROLLED) (11)

T-46-23-12

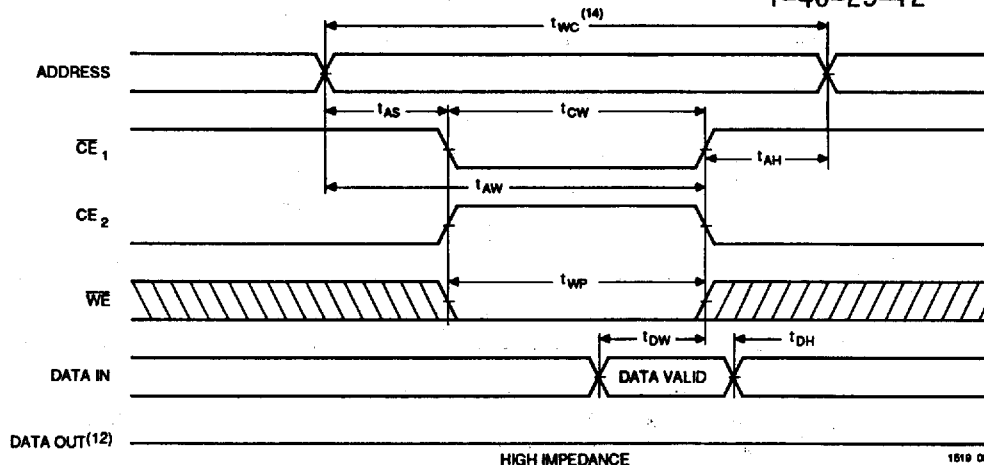

4

AC TEST CONDITIONS

Input Pulse Levels	GND to 3.0V
Input Rise and Fall Times	3ns
Input Timing Reference Level	1.5V
Output Timing Reference Level	1.5V
Output Load	See Figures 1 and 2

1519 12

TRUTH TABLE

Mode	CE ₁	CE ₂	OE	WE	I/O	Power
Standby	H	X	X	X	High Z	Standby
Standby	X	L	X	X	High Z	Standby
D _{OUT} Disabled	L	H	H	H	High Z	Active
Read	L	H	L	H	D _{OUT}	Active
Write	L	H	X	L	High Z	Active

1519 13

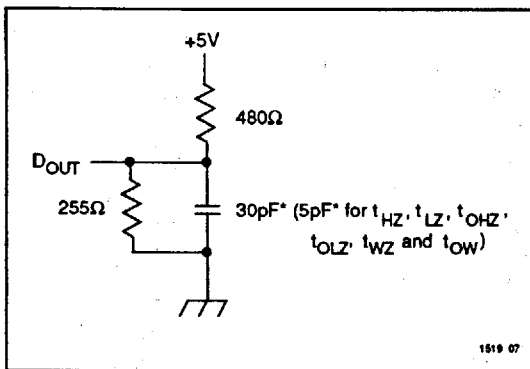

1519 07

Figure 1. Output Load

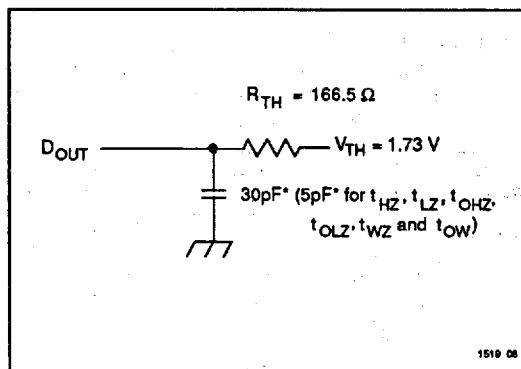

1519 08

Figure 2. Thevenin Equivalent

* including scope and test fixture.

Note:

Because of the ultra-high speed of the P4C164/L, care must be taken when testing this device; an inadequate setup can cause a normal functioning part to be rejected as faulty. Long high-inductance leads that cause supply bounce must be avoided by bringing the V_{CC} and ground planes directly up to the contactor fingers. A 0.01 μF high frequency capacitor is also required between V_{CC} and

ground. To avoid signal reflections, proper termination must be used; for example, a 50Ω test environment should be terminated into a 50Ω load with 1.73V (Thevenin Voltage) at the comparator input, and a 116Ω resistor must be used in series with D_{OUT} to match 166Ω (Thevenin Resistance).

ORDERING INFORMATION

T-46-23-12

Performance Semiconductor's part numbering scheme is as follows:

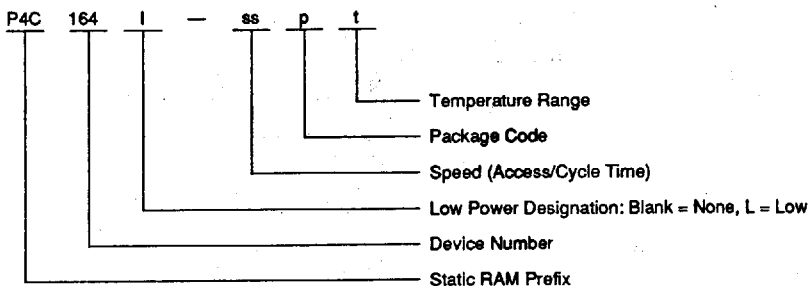

- I = Ultra-low standby power designator L, if available.
- ss = Speed (access/cycle time in ns), e.g., 25, 35
- p = Package code, i.e., P, J, C, DW, L
- t = Temperature range, i.e., C, M, MB.

1519 00

PACKAGE SUFFIX

Package Suffix	Description
P	Plastic DIP, 300 mil wide standard
J	Plastic SOJ, 300 mil wide standard
C	Sidebrazed DIP, 300 mil wide
DW	CERDIP, 600 mil wide
L	Leadless Chip Carrier (ceramic)
D	CERDIP, 300 mil wide standard

1519 14

TEMPERATURE RANGE SUFFIX

Temperature Range Suffix	Description
C	Commercial Temperature Range, 0°C to +70°C.
M	Military Temperature Range, -55°C to +125°C.
MB	Mil. Temp. with MIL-STD-883D Class B compliance

1519 15

SELECTION GUIDE

The P4C164 is available in the following temperature, speed and package options. The P4C164L is available for military temperatures with access times of 25ns and slower. The P4C164/164L is available to Standardized Military Drawings 5962-85525 and 5962-38294. Check Mil-Bul-103 for current listing of part types.

Temp. Range	Package	Speed					
		12	15	20	25	35	45
Com'l	Plastic DIP	-12PC	-15PC	-20PC	-25PC	N/A	N/A
	Plastic SOJ	-12JC	-15JC	-20JC	-25JC	N/A	N/A
	CERDIP (300 mil)	-12DC	-15DC	-20DC	-25DC	N/A	N/A
	LCC	N/A	-15LC	-20LC	-25LC	N/A	N/A
Mil. Temp	CERDIP (300 mil)	N/A	N/A	-20DM	-25DM	-35DM	-45DM
	CERDIP (600 mil)	N/A	N/A	-20DWM	-25DWM	-35DWM	-45DWM
	LCC	N/A	N/A	-20LM	-25LM	-35LM	-45LM
Military Proc'd*	CERDIP (300 mil)	N/A	N/A	-20DMB	-25DMB	-35DMB	-45DMB
	CERDIP (600 mil)	N/A	N/A	-20DWMB	-25DWMB	-35DWMB	-45DWMB
	LCC	N/A	N/A	-20LMB	-25LMB	-35LMB	-45LMB

1519 16

■ Advance Information

* Military temperature range with MIL-STD-883 Revision D, Class B processing.
N/A = Not available