

Version: *Preliminary*

TECHNICAL SPECIFICATION  
MODEL NO. : P50AN4AP01

Customer's Confirmation

Date \_\_\_\_\_

By \_\_\_\_\_

PVI's Confirmation

Confirmed By \_\_\_\_\_

Prepared By \_\_\_\_\_

**PRIME VIEW INTERNATIONAL CO.,LTD.**  
3,LI SHIN RD. 1,SCIENCE-BASED INDUSTRIAL  
PARK,HSINCHU,TAIWAN,R.O.C.  
<http://www.pvi.com.tw>

Date : Oct 22, 1999

This technical specification is subject to change without notice.  
Please return 1 copy with your signature on this page for approval.

---

# TECHNICAL SPECIFICATION

## CONTENTS

<i>NO.</i>	<i>ITEM</i>	<i>PAGE</i>
-	Cover	1
-	Contents	2
1	Application	3
2	Features	3
3	Mechanical Specifications	3
4	Mechanical Drawing of TFT-LCD module	4
5	Input / Output Terminals	5
6	Absolute Maximum Ratings	8
7	Electrical Characteristics	9
8	Optical Characteristics	16
9	Reliability Test	19
10	Block Diagram	20
11	Packing	21
-	Revision History	22

### 1. Application

This technical spec. applies to 5" color TFT-LCD module, P50AN4

### 2. Features

- . Compatible with NTSC and PAL system
- . Pixel in stripe configuration
- . Slim and compact
- . Active area / Outline area = 66.5 %
- . High brightness
- . Viewing Direction : 6 o'clock

### 3. Mechanical Specifications

<b>Parameter</b>	<b>Specifications</b>	<b>Unit</b>
Screen Size	5 (diagonal)	inch
Display Format	960×234	dot
Active Area	102.6 (H)×73.9 (V)	mm
Dot Pitch	0.107 (H)×0.316 (V)	mm
Pixel Configuration	Stripe	
Outline Dimension	127.4 (w)×92.8(H)×12.9 (D)	mm
Weight	190	g

4. Mechanical Drawing of TFT-LCD Module  
See sattach file.

**5. Input / Output Terminals**
**5-1) TFT-LCD Panel Driving**

Pin No	Symbol	I/O	Description	Remark
1	$\overline{\text{HSY}}$	I/O	Horizontal Sync. Input / Output	Note 5-1
2	FRP	O	Video Polarity Alternating Signal	
3	CSY	I	Composite Sync. Signal	Note 5-1
4	$V_{\text{GH}}$	I	Supply Voltage for Gate Driver (Hi level)	Note 5-2
5	$V_{\text{GL}}$	I	Supply Voltage for Gate Driver (Low level)	Note 5-3
6	$V_{\text{B}}$	I	Video Signal (Blue)	
7	$V_{\text{R}}$	I	Video Signal (Red)	
8	$V_{\text{G}}$	I	Video Signal (Green)	
9	GND	I	Ground	
10	$V_{\text{DD}}$	I	Supply voltage for Controller	Note 5-4
11	$V_{\text{SH}}$	I	Supply voltage for source driver	Note 5-5
12	GND	I	Ground	
13	CKC	I	Control pin for select I/O signal	Note 5-1
14	$\overline{\text{VSY}}$	I/O	Vertical Sync. Input/ Output	Note 5-1
15	PSI	O	Synchronize Pulse for Decoder	Note 5-6
16	PSC	O	Synchronize Pulse for DC-DC Converter	Note 5-7
17	VIY	I	Vertical Sync. Input Pin for reset Vertical Counter	Note 5-1
18	UD	I	UP/DOWN Control	Note 5-9
19	RL	I	Right/Left Shift Control	Note 5-8
20	NP	I	NTSC/PAL Input	Note 5-10

Note 5-1 : Pin 13 (CKC) can select the function for Pin 1 ( $\overline{\text{HSY}}$ ), Pin 3 (CSY), and Pin 14 ( $\overline{\text{VSY}}$ ).

Pin 13 (CKC)	Pin 1 ( $\overline{\text{HSY}}$ )	Pin 3 (CSY)	Pin 14 ( $\overline{\text{VSY}}$ )
Hi	$\overline{\text{HSY}}$ Output	CSY Input	$\overline{\text{VSY}}$ Output
Low	External Horizontal Sync Input	External Clock Input	External Vertical Sync Input

Note 5-1-1: CKC= High:

- If CKC=1, the phase lock loop (PLL) is adopted in the LCD module.
- Inputs CSY, the controller of LCD module will separate the Vertical Sync and Horizontal Sync from CSY.
- Output Horizontal Sync ( $\overline{\text{HSY}}$ , Pin 1) and Vertical Sync ( $\overline{\text{VSY}}$ , Pin 14).
- The internal detect will detect Vertical Sync to reset the vertical counter.

Note 5-1-2: CKC= Low

- a. If CKC=0, the phase lock loop (PLL) is not adopted in the LCD module.
- b. If CKC=0, the external clock input frequency of Pin 3 is 11.8 MHz.
- c. Input external Vertical Sync (VIY, Pin 17) and Horizontal Sync (Pin 1) to synchronize the LCD module. External Horizontal Sync and External Vertical Sync input pulse can be high going or low going.
- d. The pulse width of external Horizontal Sync input is  $4.7\mu s \pm 2\mu s$ . The pulse width of external Vertical Sync input is 2H~4H.
- e. The pulse length of external input Vertical Sync of NTSC system is  $262H \pm 4H$  and PAL system is  $312H \pm 4H$ .

Note 5-1-3: The timing chart of  $\overline{HSY}$  and external Horizontal input:

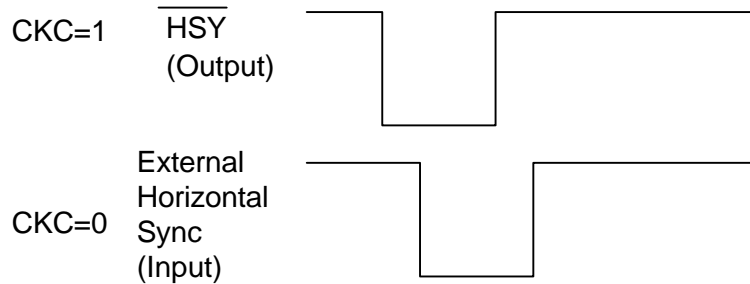

Note 5-1-4: If there is any question about CKC=0, please contact PVI.

Note 5-2:  $V_{GH}$  TYP. = +20V

Note 5-3:  $V_{GL}$  TYP. = -5V

Note 5-4:  $V_{DD}$  TYP. = +5V

Note 5-5:  $V_{SH}$  TYP. = +14V

Note 5-6: The frequency of PSI is 15.75KHz.

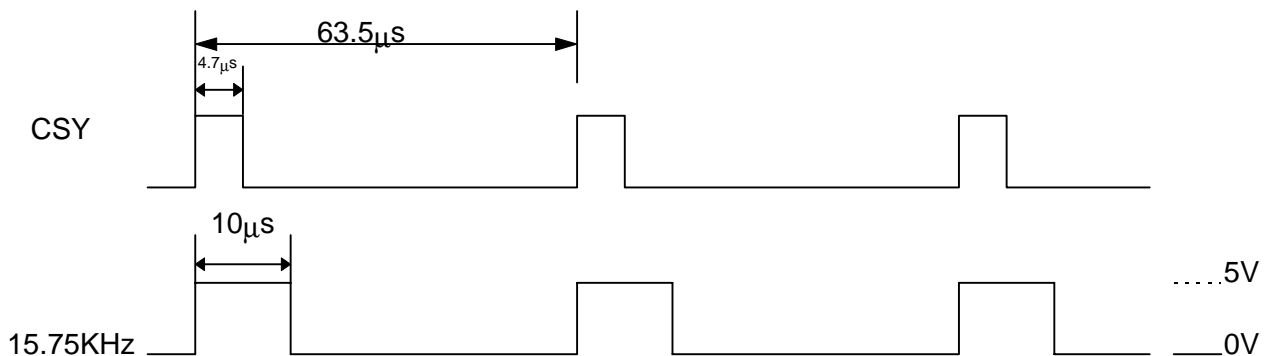

Note 5-7: The frequency of PSC is 70KHz or 39KHz(Default is 70KHz).

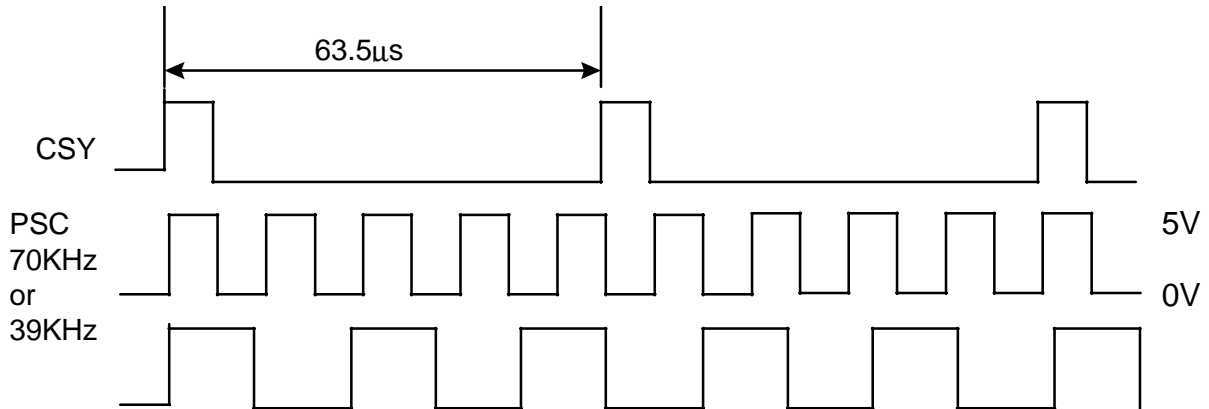

Note 5-8: Default is Hi (+5V) for shift Right; and inputs Low (0V) for inverse (shift Left). This version do not apply.

Note 5-9: Default is Hi (+5V) for DOWN and Low (0V) is for UP. This version do not apply.

Note 5-10: NTSC= Hi (+5V), PAL=LOW (0V)

5-2) Backlight driving

Pin No	Symbol	Description	Remark
1	VL1	Input terminal (Hi voltage side)	
2	VL2	Input terminal (Low voltage side)	Note 5-11

Note 5-11 : Low voltage side of backlight inverter connects with Ground of inverter circuits.

5-3) Input / Output Connector

A) LCD Module Connector

Pin No. : 20

Pitch : 1.0 mm

B) Backlight Connector

JST BHR-03VS-1

Pin No. : 3

Pitch : 4 mm

**6. Absolute Maximum Ratings:**

GND = 0 V , Ta = 25 °C

Parameter	Symbol	MIN.	MAX.	Unit	Remark	
Supply Voltage for Source Driver	V <sub>SH</sub>	-0.5	+16	V		
Supply Voltage for Gate Driver	H Level	V <sub>GH</sub>	-0.3	+26.5	V	
	L Level	V <sub>GL</sub>	-7	+20.3	V	
Supply voltage for controller	V <sub>DD</sub>	-0.3	+6.5	V		
Analog input signals	V <sub>B</sub> , V <sub>R</sub> , V <sub>G</sub>		12	V		
Digital input signals		-0.5	+5.5	V	Note 6-1	
Digital output signals		-0.5	+5.5	V	Note 6-2	
Storage Temperature		-30	+80	°C		
Operation Temperature		-10	+60	°C		

 Note 6-1 :  $\overline{\text{HSY}}$  ,  $\overline{\text{CSY}}$  ,  $\overline{\text{VSY}}$  ,  $\overline{\text{CKC}}$ 

 Note 6-2 :  $\overline{\text{FRP}}$  ,  $\overline{\text{HSY}}$  ,  $\overline{\text{VSY}}$  ,  $\overline{\text{PSI}}$  ,  $\overline{\text{PSC}}$ 
**7. Electrical Characteristics**
**7-1) Recommended Operating Conditions:**

A) Driving for TFT-LCD panel

GND = 0V , Ta = 25 °C

Parameter	Symbol	MIN.	TYP	MAX.	Unit	Remark	
Supply voltage for source driver	V <sub>SH</sub>	+13.5	+14	+14.5	V		
Supply voltage for gate driver	H Level	V <sub>GH</sub>	+19	+20	+24	V	
	L level	V <sub>GL</sub>	-5.5	-5	-4	V	
Supply voltage for controller	V <sub>DD</sub>	+4.7	+5	+5.3	V		
Analog input voltage	Amplitude	V <sub>B</sub> , V <sub>R</sub> , V <sub>G</sub>	+2	-	+12	V	
	DC component		+4	+6	+8	V	
Digital input voltage	H level		+2.4	-	+5	V	Note 7-1
	L level		-0.3	-	+0.8	V	
Digital output voltage	H level		+2.4	+4	+5	V	Note 7-2
	L level		0	-	+0.5	V	

 Note 7-1 :  $\overline{\text{HSY}}$  ,  $\overline{\text{CSY}}$  ,  $\overline{\text{VSY}}$  ,  $\overline{\text{CKC}}$  ,

 Note 7-2 :  $\overline{\text{HSY}}$  ,  $\overline{\text{FRP}}$  ,  $\overline{\text{VSY}}$  ,  $\overline{\text{PSI}}$  ,  $\overline{\text{PSC}}$ 

B) Driving for backlight

Ta = 25 °C

Parameter	Symbol	Min.	Typ.	Max.	Unit	Remark
Lamp voltage	V <sub>L</sub>	380	420	460	Vrms	I <sub>L</sub> =6mA
Lamp current	I <sub>L</sub>	4	6	8	mA	
Lamp frequency	P <sub>L</sub>	20		60	KHz	Note 7-3
Kick-off voltage	V <sub>s</sub>			1500	Vrms	



Note 7-3: The waveform of lamp driving voltage should as close to a perfect SIN wave as possible.

7-2) Power Consumption

Parameter	Symbol	Conditions	TYP.	MAX	Unit	Remark
Supply current for Gate Driver (Hi level)	$I_{GH}$	$V_{GH} = +20V$	4.8		mA	
Supply current for Gate Driver (Low level)	$I_{GL}$	$V_{GL} = -5V$	3.5		mA	
Supply current for Source Driver	$I_{SH}$	$V_{SH} = +14V$	31.0		mA	
Supply current for controller	$I_{DD}$	$V_{DD} = +5V$	22.6		mA	
LCD Panel Power Consumption			0.66		W	Note 7-4
Backlight Lamp Power Consumption			2.52		W	Note 7-5
Total Power Consumption			3.18		W	

Note 7-4 : The power consumption for backlight is not included.

Note 7-5 : Backlight lamp power consumption calculated by  $I_L \times V_L$ .

7-3) Input / Output signal timing chart

Parameter	Symbol	MIN.	TYP.	MAX.	Unit	Remarks
Horizontal Sync. Output Pulse	Width	$T_{HO}$	4.2	4.7	5.2	$\mu s$
	Phase Difference	$T_{HP}$	0	2		$\mu s$
	Rising Time	$T_{HR}$	-	-	0.5	$\mu s$
	Falling Time	$T_{HF}$	-	-	0.5	$\mu s$
Vertical Sync. Output Pulse	Width	$T_{VO}$	-	4H	-	$\mu s$ H=1/15.75K HZ
	Phase Difference	$T_{VPO}$	-	1H	-	$\mu s$ odd field
	Phase Difference	$T_{VPE}$	-	1.5H	-	$\mu s$ even field
	Rising Time	$T_{VR}$	-	-	2	$\mu s$
	Frequency	$f_{FRP}$	7.67	7.87	8.07	KHz
Polarity Alternating Signal	Delay time	$T_{FD}$	-	-	4	$\mu s$
	Falling Time	$T_{VF}$	-	-	2	$\mu s$

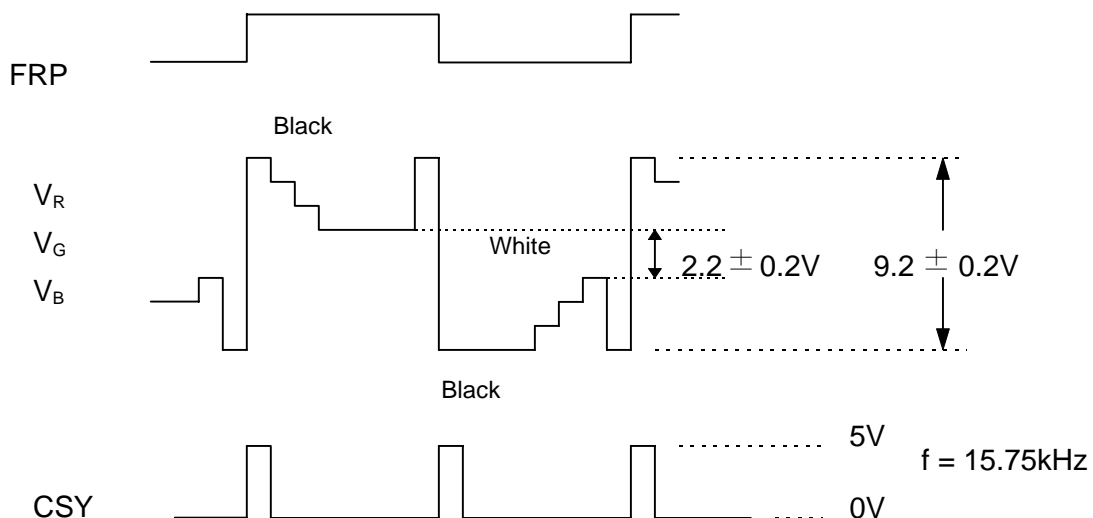

7-4) Display Time Range

A) When sync. signal of NTSC system is applied.

a) Horizontally  
12.6 ~ 63.39  $\mu$ s.

b) Vertical  
19 ~ 253 H

B) When sync. signal of PAL system is applied.

a) Horizontally  
13.0 ~ 63.8  $\mu$ s .

b) Vertical  
26 ~ 298 H

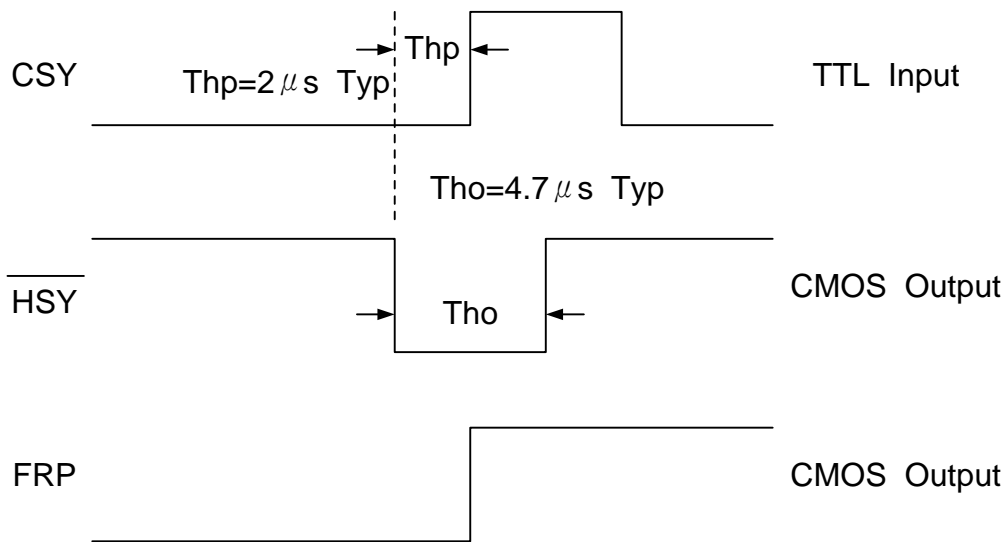

**C) NTSC System**

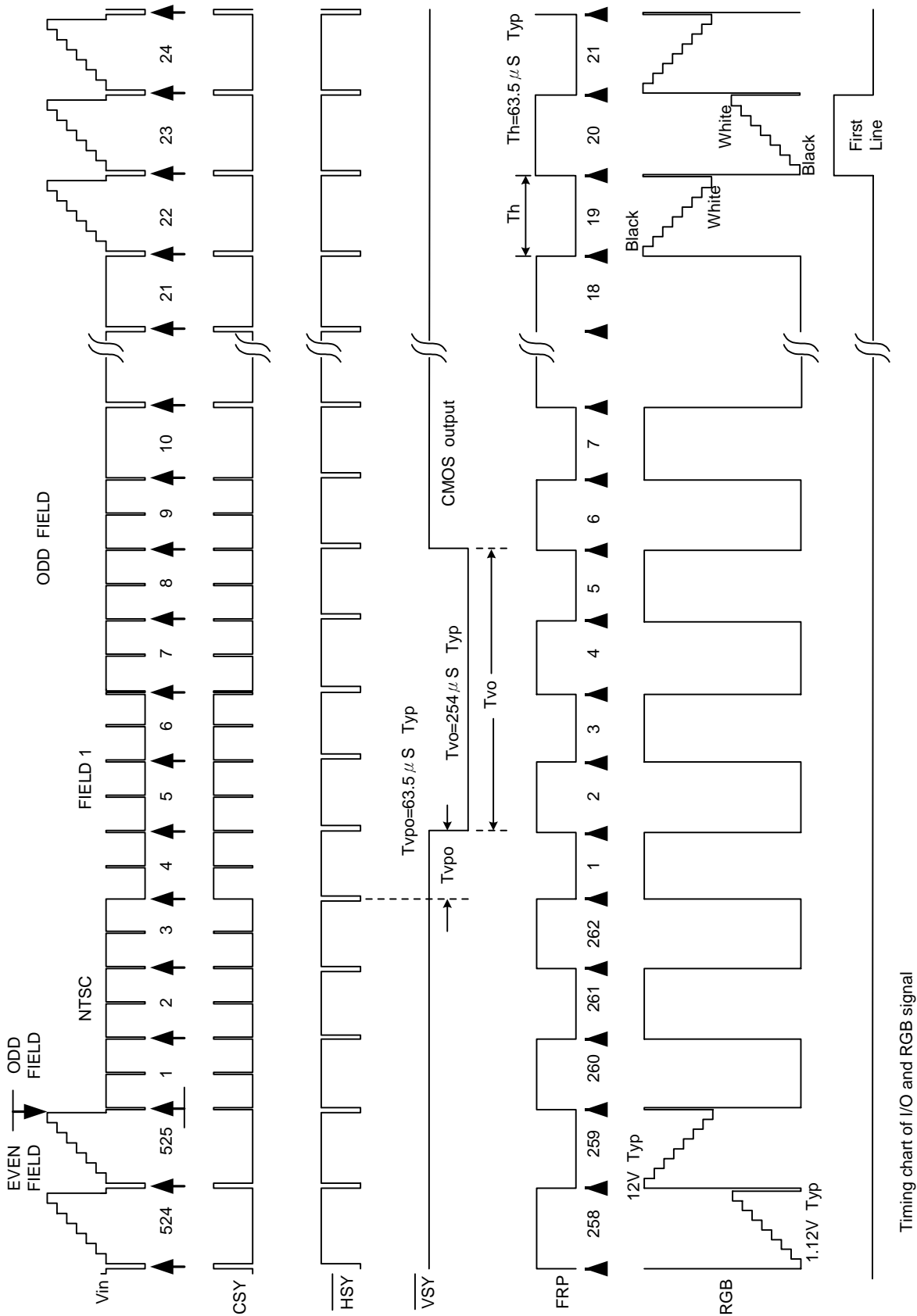

Timing chart of I/O and RGB signal

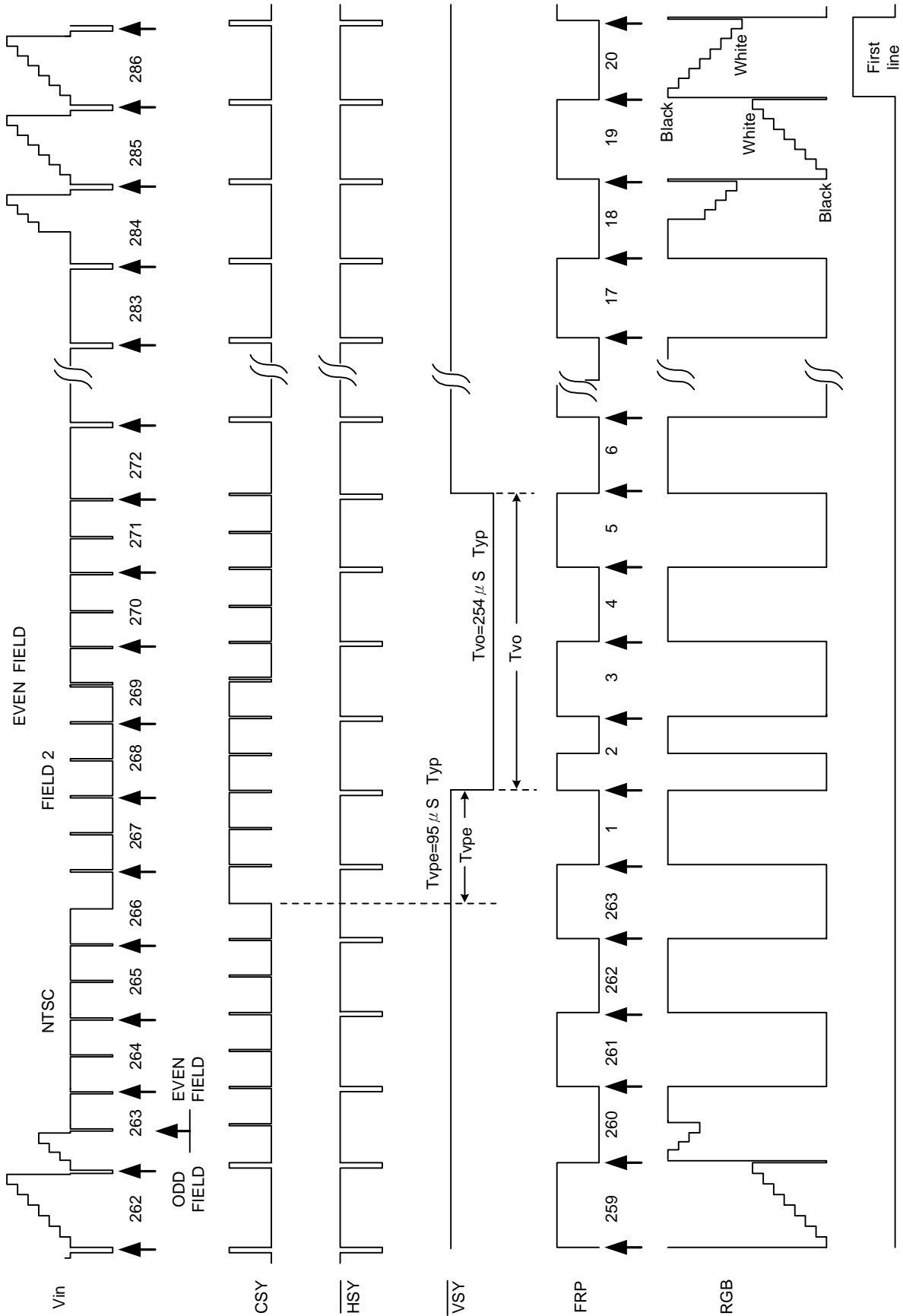

Timing chart of I/O and RGB signal

D) PAL System

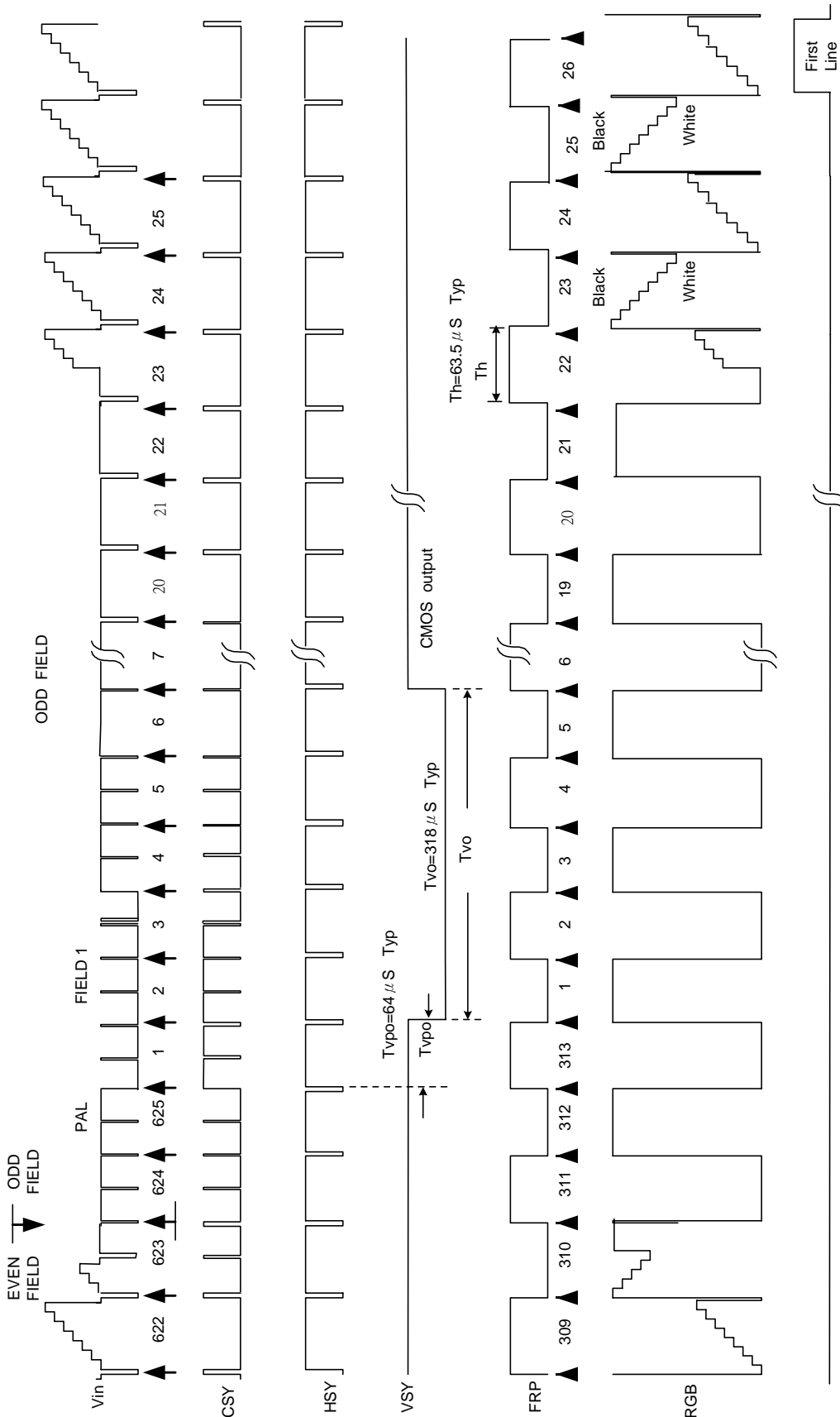

Timing chart of I/O and RGB signal

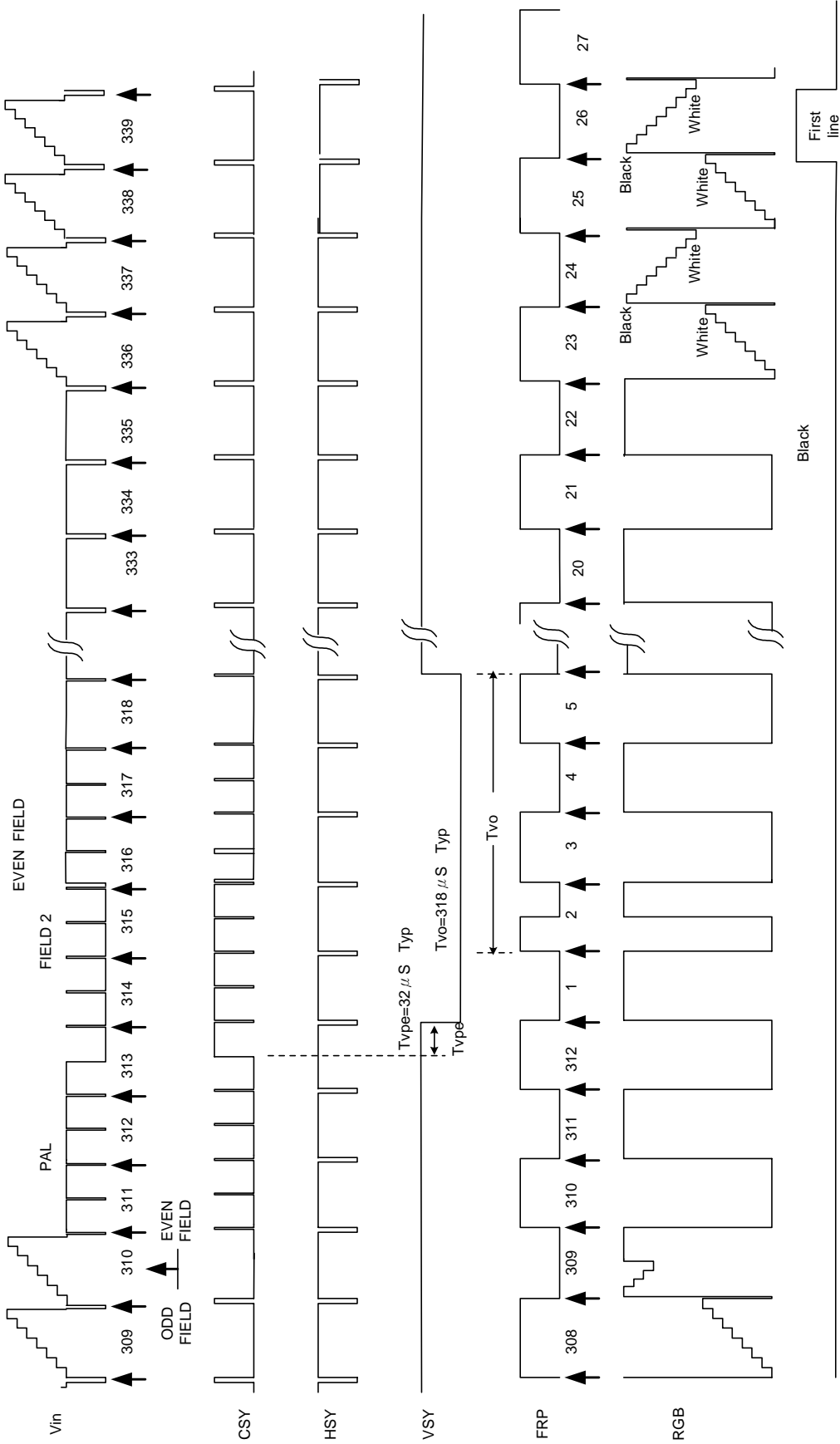

Timing chart of I/O and RGB signal

E) Display Timing

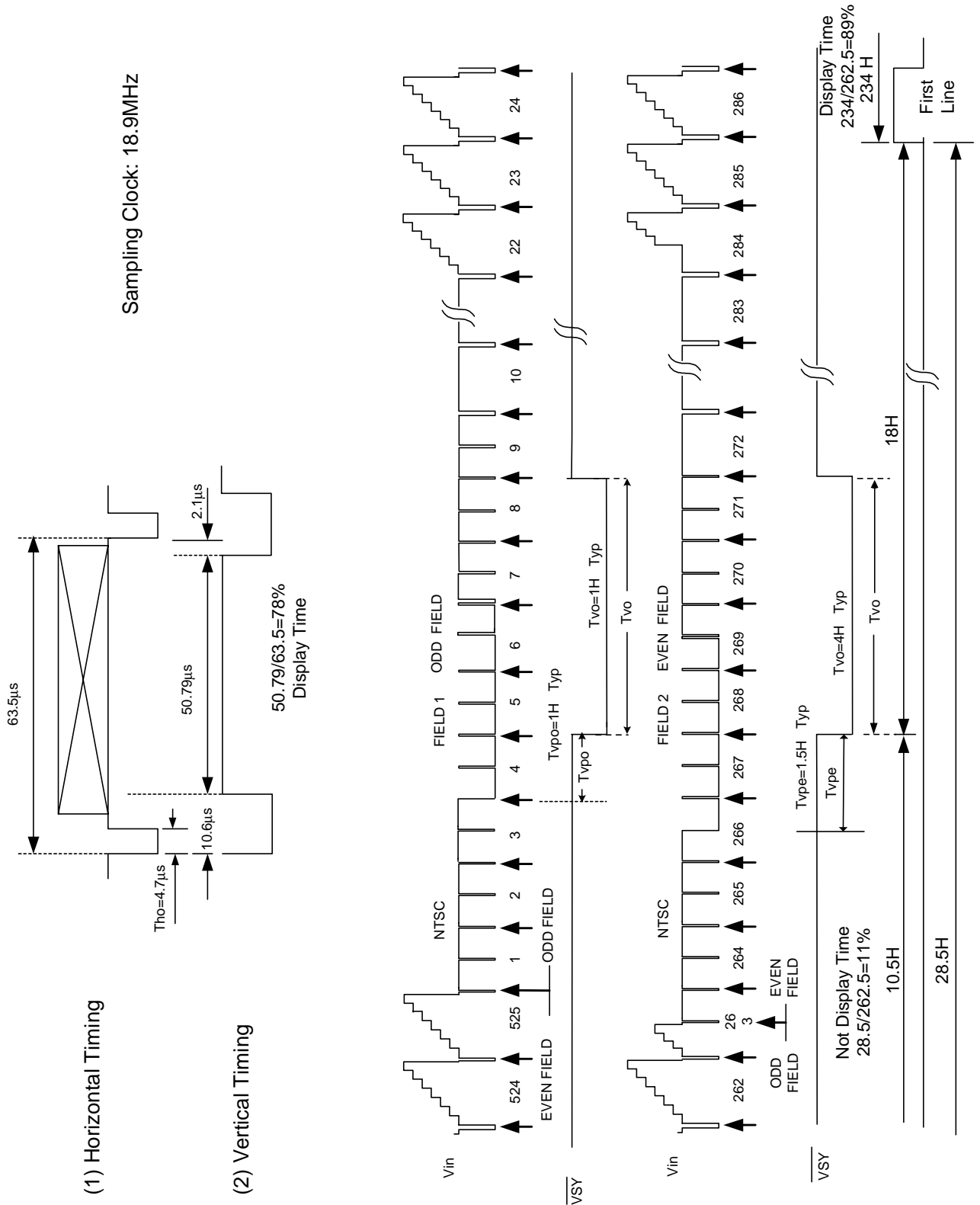

8. Optical Characteristics

8-1) Specification:

Ta = 25°C

Parameter		Symbol	Condition	MIN.	TYP.	MAX.	Unit	Remarks
Viewing Angle	Horizontal	$\theta$	CR > 10	±45	±55		deg	Note 8-1
	Vertical	$\theta$ (to 12 o'clock)		30	35		deg	Note 8-1
		$\theta$ (to 6 o'clock)		10	15		deg	Note 8-1
Contrast Ratio		CR		80	120			Note8-1, 8-2
Response time	Rise	Tr	$\theta = 0^\circ$			30	ms	Note 8-4
	Fall	Tf				50	ms	
Brightness				300	320		cd/m <sup>2</sup>	Note 8-3
White Chromaticity	x			0.250	0.300	0.350		Note 8-3
	y			0.300	0.350	0.400		
Lamp Life Time(+25°C)			Continuous	10,000			hr	

Note 8-1 : The definitions of viewing angles are as follows.

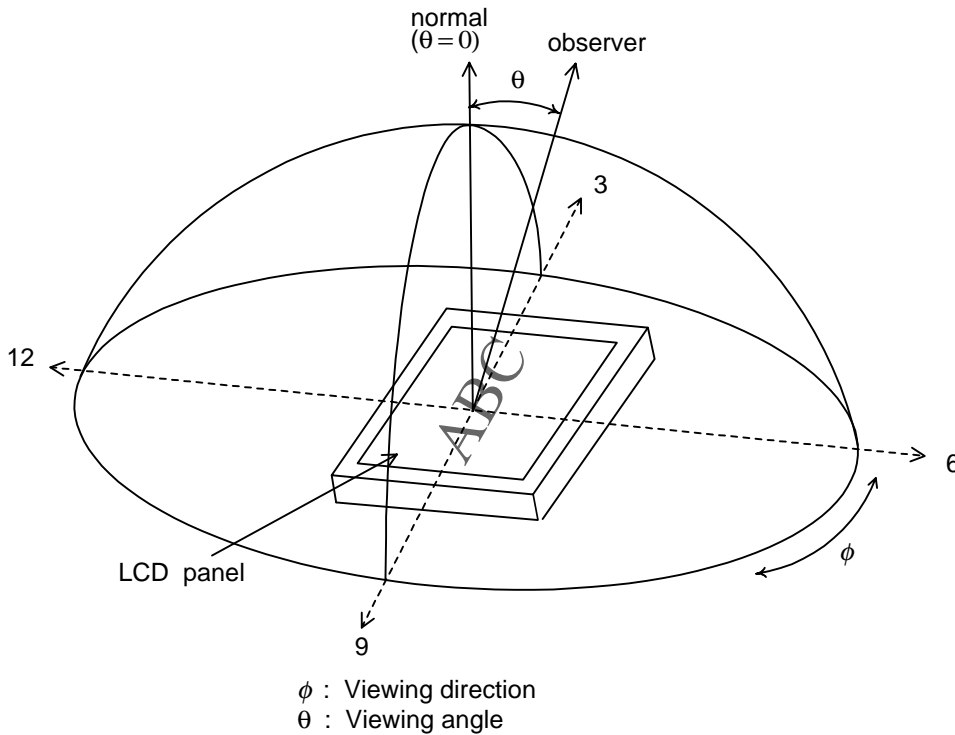

Note 8-2 :  $CR = \frac{\text{Luminance when LCD is White}}{\text{Luminance when LCD is Black}}$

Contrast Ratio is measured in optimum common electrode voltage.  
 Test configurations see section 8-2.



Note 8-3: Topcon BM-7(fast) luminance meter 2° field of view is used in the testing (after 20~30 minutes operation).

Note 8-4: The definition of response time:

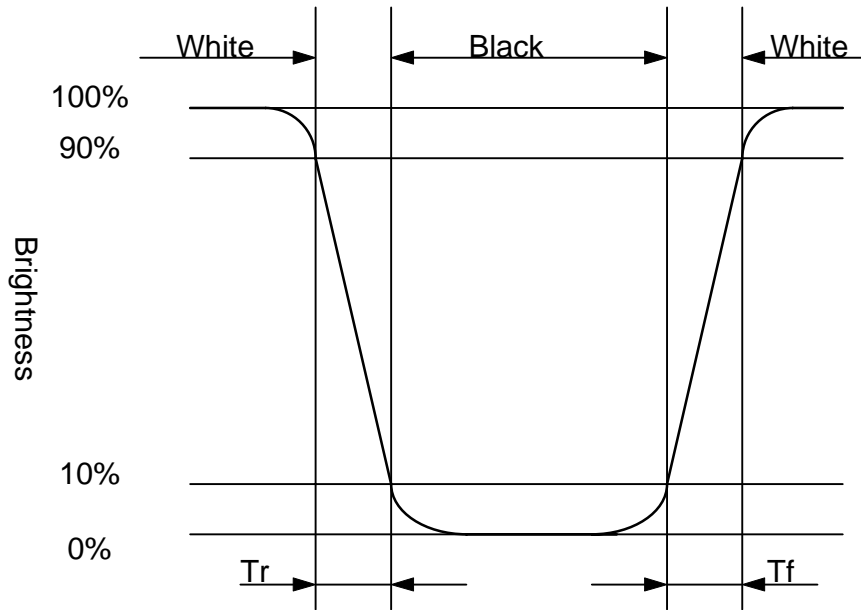

8-2) Test Configuration

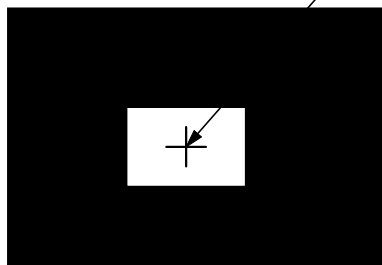
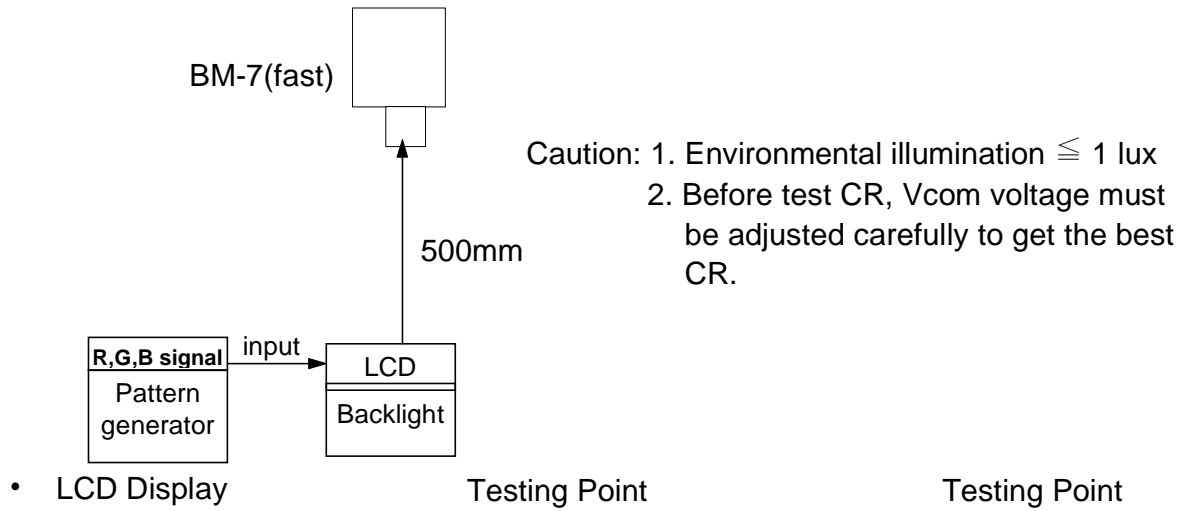

Pattern A

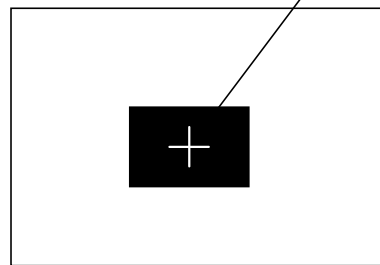

Pattern B

- R, G, B Waveform of Pattern A at Testing Point

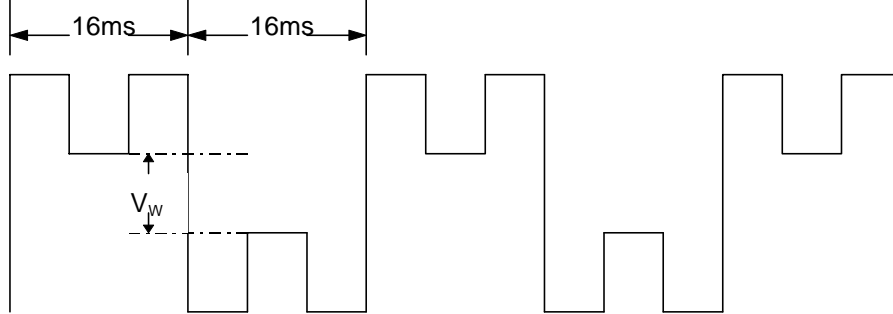

$V_w = 2.2V \pm 0.2V$

- G, B Waveform of Pattern B at Testing Point

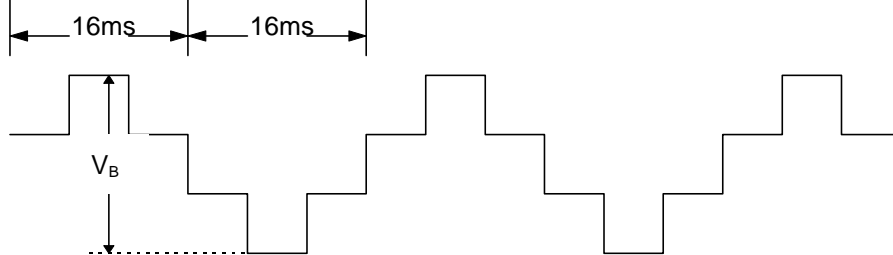

$V_b = 9.2V \pm 0.2V$

**9. Reliability Specification**

No	Test Item	Test Condition
1	High Temperature Storage Test	Ta = +80 °C, 240 hrs
2	Low Temperature Storage Test	Ta = -30°C, 240 hrs
3	High Temperature Operation Test	Ta = +60 °C, 240 hrs
4	Low Temperature Operation Test	Ta = -10 °C, 240 hrs
5	High Temperature & High Humidity Operation Test	Ta = +60°C, 95%RH, 240 hrs
6	Thermal Cycling Test (non-operating)	-25°C → +25°C → +70°C, 200 Cycles 30 min    5min    30 min
7	Vibration Test (non-operating)	Frequency : 10 ~ 55 Hz Amplitude : 1.5 mm Sweep time: 11 mins Test period: 6 Cycles for each direction of X, Y, Z
8	Shock Test (non-operating)	100G, 6ms Direction: ±X, ±Y, ±Z Cycle: 3 times
9	Electrostatic Discharge Test	150pF, 330Ω Air: ±15KV; Contact: ±8KV 10 times/point, 5 points/panel face

Ta: ambient temperature

**[Criteria]**

Under the display quality test conditions with normal operation state, there should be no change which may affect practical display function.

10. Block Diagram

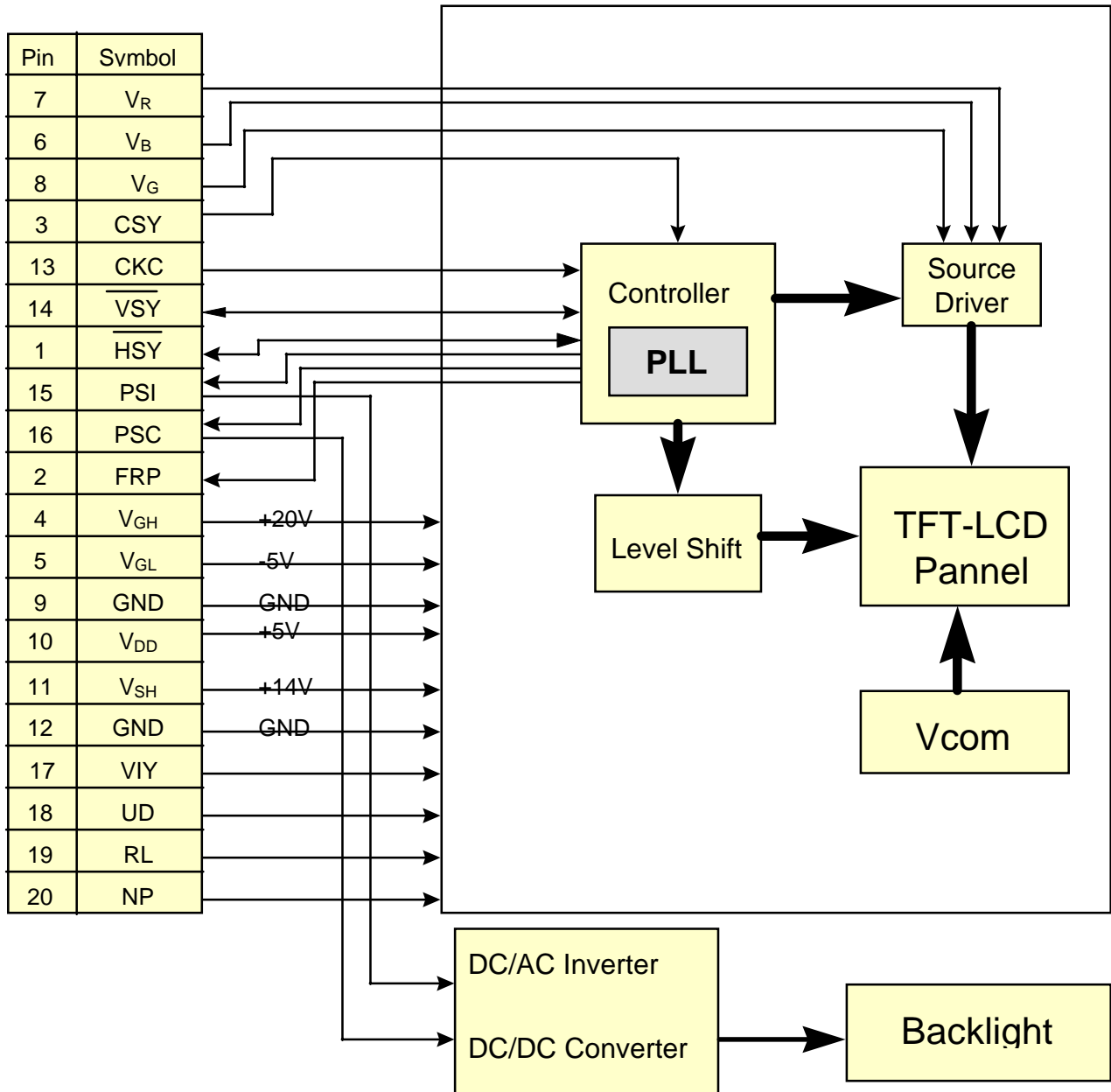

11. Packing

**NOTE:**  
 1.Q'TY: 10pcs panel/carton.  
 2.Dimension: 355\*300\*142mm  
 3.Weight: 2.6Kg

ITEM	PART NO.	DESCRIPTION	QTY	REMARK
5	50-0100011	carton355*300*142mm	1	
4	50-0300021	FOAM 345*290*50mm	2	
3	50-0500011	防静电袋 150*180mm	10	
2		5" PANEL	10	
1	50-0300011	FOAM 345*290*20mm	2	

MTL.SPEC.		UNSPECIFIED TOL'S		REMARK		元太科技工業股份有限公司 Prime View International Co.,Ltd.	
		ANGLE					
		ROUGHNESS				DWG.TITLE <b>5" Packing DWG</b>	
APPROVE		SCALE	UNIT	SHEET	1 OF 2		
CHECK		MTL.NO.		DWG.NO.		REV.	A4 SIZE
DESIGN	陳萬典	06.30.99			01		

---

Revision History

Rev.	Issued Date	Revised Contents
0	Oct 22, 1999	NEW

TENTATIVE

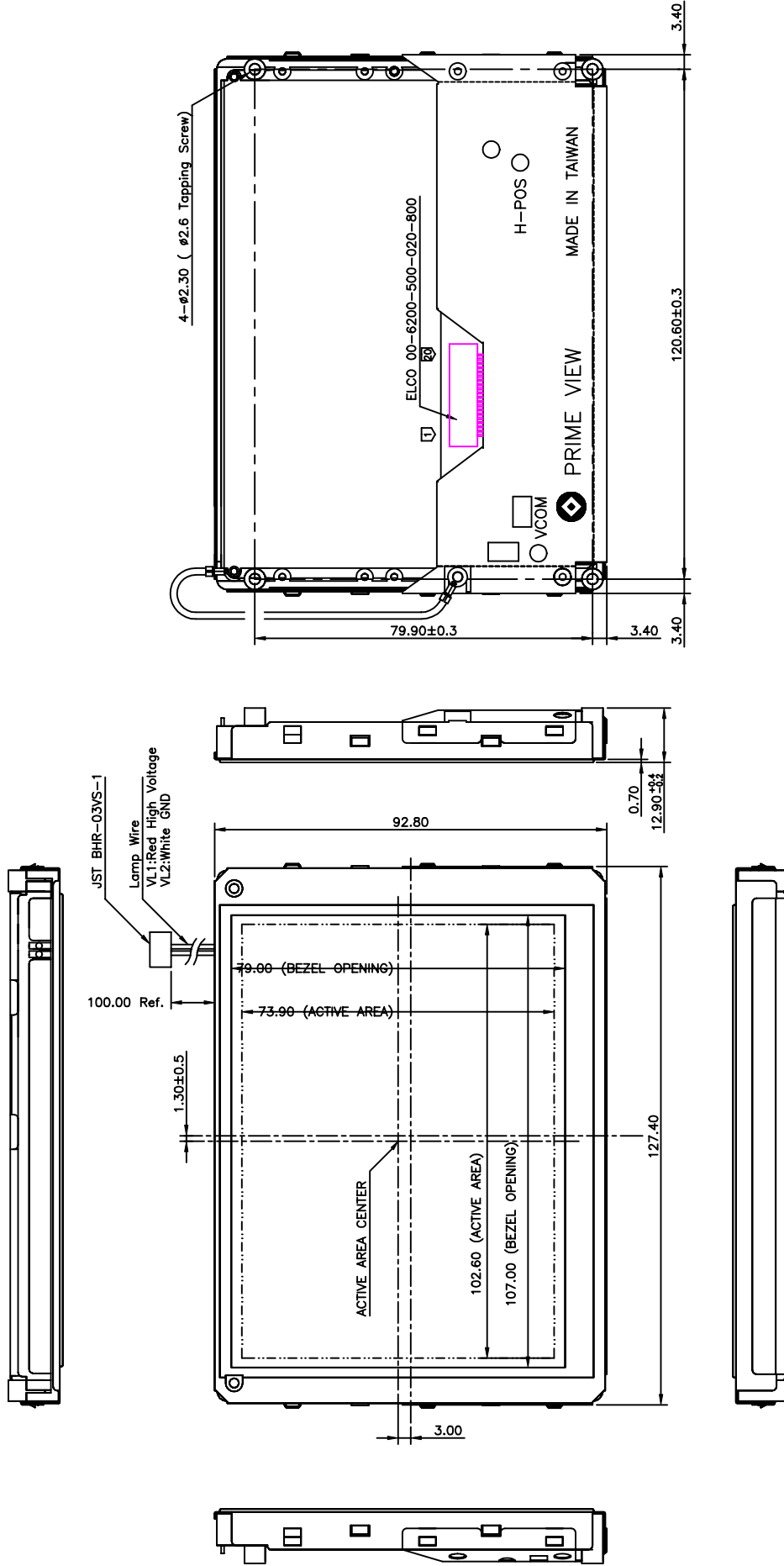

MTL.SPEC.	UNSPECIFIED TOL'S ±0.4	REMARK	元太科技工業股份有限公司 Prime View International Co.,Ltd.	
APPROVE	ANGLE	SCALE	UNIT	DWG.TITLE
CHECK	ROUGHNESS	1/1	MM	P50AN4 Model Dimension
DESIGN				DWG.NO.
黃華男	'99.05.28			REV. A3
				01 SIZE