

MCT photoconductive detector P2748/P5274 series, P3257-50

Dewar type detector with high sensitivity and high-speed response in long wavelength range



Features

- Choice of spectral response range (up to 25 μm)
The band gap can be adjusted by controlling the composition ratio of HgTe and CdTe. Utilizing this fact, various types are available in different spectral characteristics.
- Photoconductive element that decreases its resistance by input of infrared light
- Micro-cooled type available
This type of cooling does not require pour-filled liquid nitrogen.
- Custom devices available
Custom devices not listed in this catalog are also available with different spectral response, active area sizes and number of elements.
Glass dewar type not requiring repumping is also provided.

Applications

- FTIR
- Infrared spectrophotometer
- Thermal imaging
- Remote sensing
- CO₂ laser detection

Accessories (Optional)

- Valve operator A3515
- Amplifiers for dewar type MCT photoconductive detector C5185
- Power supply for amplifier C3871
- Infrared detector module with preamp P7752-10

■ General rating / Absolute maximum ratings

Type No.	Dimensional outline/ Window material *1	Package	Cooling	Active area (mm)	Nitrogen maintenance time Min. (h)	Absolute maximum ratings		
						Allowable current (mA)	Operating temperature Topr (°C)	Storage temperature Tstg (°C)
P2748-40	①/Z	Side-on type metal dewar	LN ₂	1 × 1	12	40	-40 to +60	-55 to +60
P2748-41	②/Z	Head-on type metal dewar		1 × 1		40		
P2748-42	①/Z	Side-on type metal dewar		0.25 × 0.25		20		
P5274				1 × 1		40		
P5274-01				①/K		1 × 1		
P3257-50	③/Z	Stirling type metal	Micro-cooled	1 × 1	-	40	-40 to +55	-45 to +55

■ Electrical and optical characteristics (Typ. unless otherwise noted)

Type No.	Measurement condition Element temperature T (°C)	Peak sensitivity wavelength λ _p (μm)	Cut-off wavelength λ _c (μm)	Photo sensitivity *2 S λ=λ _p (V/W)	D* (500, 1200, 1)		D* (λ _p , 1200, 1) (cm·Hz ^{1/2} /W)	NEP λ=λ _p (W/Hz ^{1/2})	Rise time tr 0 to 63 % (μs)	Dark resistance Rd (Ω)
					Min. (cm·Hz ^{1/2} /W)	Typ. (cm·Hz ^{1/2} /W)				
	P2748-40	-196	12	14	1000	1 × 10 ¹⁰	2 × 10 ¹⁰	4.0 × 10 ¹⁰	2.5 × 10 ⁻¹²	0.6
P2748-41	1000				2.5 × 10 ⁻¹²					
P2748-42	10000				6.3 × 10 ⁻¹²					
P5274	14		17	500	2 × 10 ⁹	1 × 10 ¹⁰	1.5 × 10 ¹⁰	6.7 × 10 ⁻¹²	0.6	30
P5274-01	17		22	250	1 × 10 ⁹	5 × 10 ⁹	1.0 × 10 ¹⁰	1.0 × 10 ⁻¹¹	0.4	100
P3257-50	12		14	1000	1 × 10 ¹⁰	2 × 10 ¹⁰	4.0 × 10 ¹⁰	2.5 × 10 ⁻¹²	0.6	40

*1: Window material K: KRS-5, Z: ZnSe

*2: Photo sensitivity changes with the bias current. The values in the above table are measured with the optimum bias current.

■ Spectral response

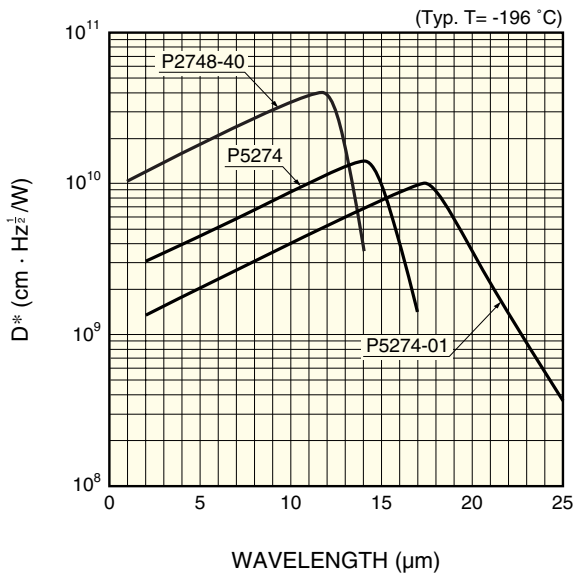

KIRD80072EC

Spectral response can be shifted upon request.

■ S/N vs. bias current

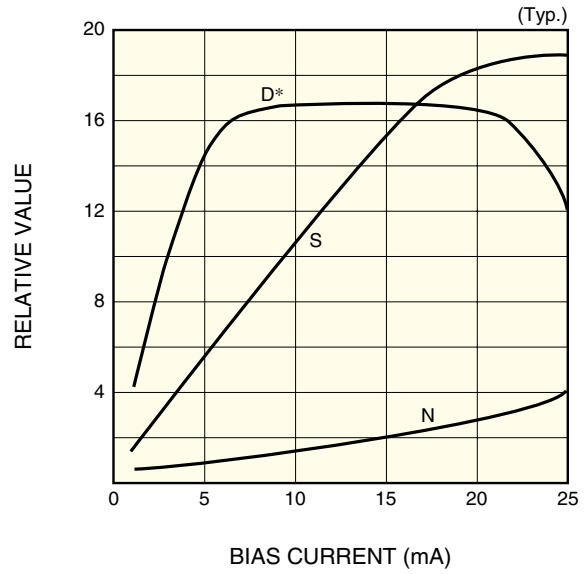

KIRD80073EB

The detector must be operated in a range where the D* becomes Max.

■ Noise frequency characteristic

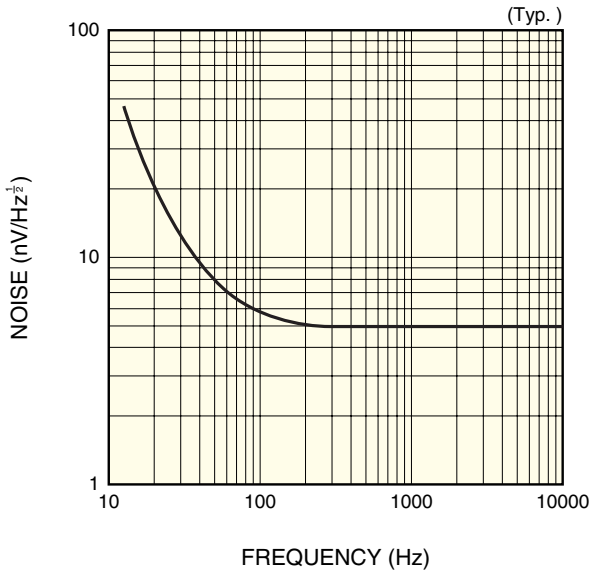

KIRD80074EC

■ Measurement circuit

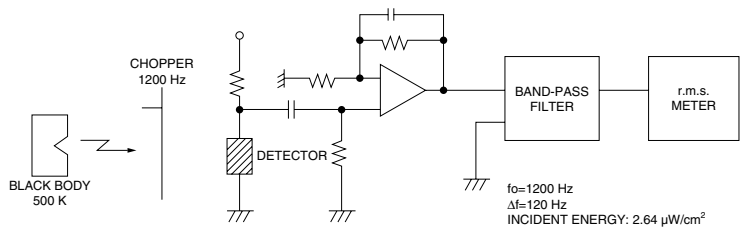

KIRD80075EA

■ Dimensional outlines (unit: mm)

① P2748-40/-42, P5274 series

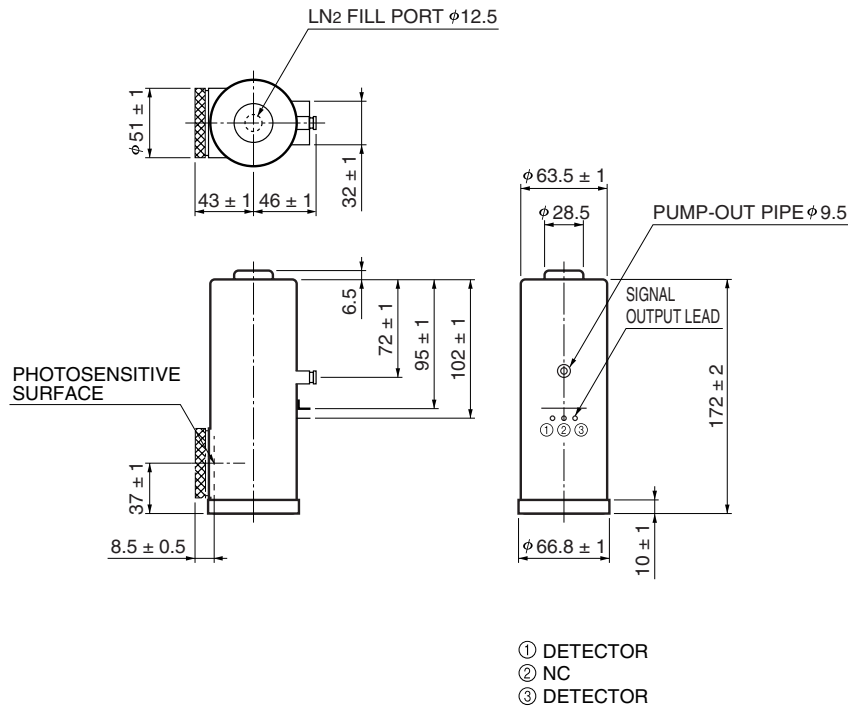

KIRDA0131EC

② P2748-41

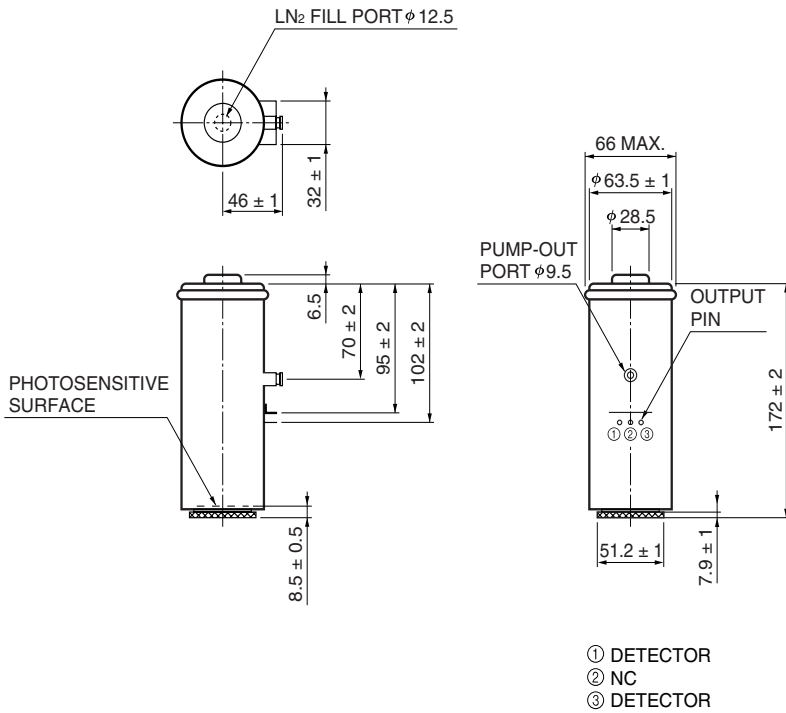

KIRDA0129EA

③ P3257-50

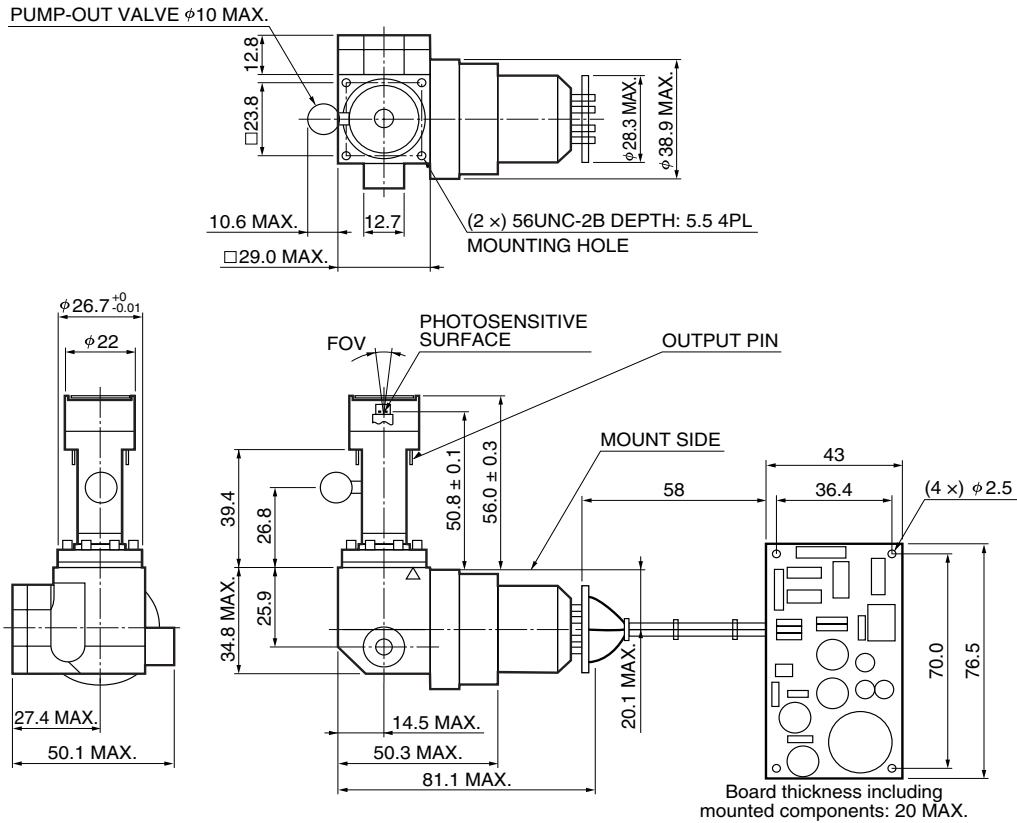

KIRDA0130EA

HAMAMATSU

Information furnished by HAMAMATSU is believed to be reliable. However, no responsibility is assumed for possible inaccuracies or omissions. Specifications are subject to change without notice. No patent rights are granted to any of the circuits described herein. ©2002 Hamamatsu Photonics K.K.

HAMAMATSU PHOTONICS K.K., Solid State Division

1126-1 Ichino-cho, Hamamatsu City, 435-8558 Japan, Telephone: (81) 053-434-3311, Fax: (81) 053-434-5184, <http://www.hamamatsu.com>

U.S.A.: Hamamatsu Corporation: 360 Foothill Road, P.O.Box 6910, Bridgewater, N.J. 08807-0910, U.S.A., Telephone: (1) 908-231-0960, Fax: (1) 908-231-1218

Germany: Hamamatsu Photonics Deutschland GmbH: Arzbergerstr. 10, D-82211 Herrsching am Ammersee, Germany, Telephone: (49) 08152-3750, Fax: (49) 08152-2658

France: Hamamatsu Photonics France S.A.R.L.: 8, Rue du Saule Trapu, Parc du Moulin de Massy, 91882 Massy Cedex, France, Telephone: 33-(1) 69 53 71 00, Fax: 33-(1) 69 53 71 10

United Kingdom: Hamamatsu Photonics UK Limited: 2 Howard Court, 10 Tewin Road, Welwyn Garden City, Hertfordshire AL7 1BW, United Kingdom, Telephone: (44) 1707-294888, Fax: (44) 1707-325777

North Europe: Hamamatsu Photonics Norden AB: Smidesvägen 12, SE-171 41 Solna, Sweden, Telephone: (46) 8-509-031-00, Fax: (46) 8-509-031-01

Italy: Hamamatsu Photonics Italia S.R.L.: Strada della Moia, 1/E, 20020 Arese, (Milano), Italy, Telephone: (39) 02-935-81-733, Fax: (39) 02-935-81-741