



Model Name: **P546HW01 V0**
Product Specification

Rev.0.6

Date: 2011/01/21

Product Functional Specification

55" Full HD Color TFT-LCD Module

Model Name: P546HW01 V0

() Preliminary Specification

(*) Final Specification

Note: This specification is subject to change without notice.



Contents

No	
	CONTENTS
	RECORD OF REVISIONS
1	GENERAL DESCRIPTION
2	ABSOLUTE MAXIMUM RATINGS
3	ELECTRICAL SPECIFICATION
3.1	SIGNAL ELECTRICAL CHARACTERISTICS
3.2	SIGNAL INTERFACE CONNECTOR
3.3	SIGNAL TIMING SPECIFICATION
3.4	SIGNAL TIMING WAVEFORM
3.5	COLOR INPUT DATA REFERENCE
3.6	BACK LIGHT POWER SPECIFICATION
3.7	POWER SEQUENCE
4	OPTICAL SPECIFICATION
5	MECHANICAL CHARACTERISTICS
5.1	PLACEMENT SUGGESTIONS
6	PACKING
7	RELIABILITY TEST
8	INTERNATIONAL STANDARD
9	PRECAUTIONS

Model Name: **P546HW01 V0**

Product Specification

Record of Revision

Rev.	Date	Page	Items	New Description	Remark
0.1	Jul,26,'10		First Draft		
0.2	Aug, 26, 10	8	Input current	Correct from 3.75 to 10.8	
0.2	Aug, 26, 10	8	Input power	Correct from 90 to 260	
0.2	Aug, 27, 10	8	Operating Frequency	Correct from 42, 44, 46 to 53, 55, 57	
0.3	Oct, 21, 10	5	Display area	Correct from 684.0 to 680.4	
0.3	Oct, 21, 10	20	Surface luminance	Correct from 5 points to 9 points	
0.4	Oct, 28, 10	19	Brightness	Correct from 450 to 500nits	
0.5	Dec, 14, 10	23-24	2D Module drawing	Cancel CN2 connector drawing	
0.6	Jan, 21, 11	5	Display Colors	Correct from 10bit to 8bit+FRC	
			Add Note 2		
		6	Unit	Correct from Volt to VDC	
			BLU input voltage	Correct from 21.6, 26.4 to -0.3, 28	
			BLU brightness control voltage	Correct from 2, 5.5 to -0.3, 7.	
		7	3.1.1 Power Consumption	Correct from 6.6 to 6	
		8	3.1.2 Input Current	Correct from 10.26, 11.375 to 9.72, and 11.88.	
			3.1.2 Input Power	Correct from 246, 273 to 233 and 285.	
		11	The 10 bits LVDS input data mapping	Modify NS mode	
		12	The 8 bits LVDS input data mapping	Modify note	
		19	4.0 Surface Luminance (White)	Correct from 450 to 400.	
		22	Add placement suggestion	5.1 placement suggestion	
		25	Reliability test item 1	300hrs=>500hrs	
		25	Reliability test item 2	300hrs=>500hrs	
		25	Reliability test item 3	300hrs=>500hrs	
		25	Reliability test item 4	300hrs=>500hrs	
		25	Reliability test item 5	300hrs=>500hrs	



1. General Description

This specification applies to the 55 inch Color TFT-LCD Module P546HW01 V0. This LCD module has a TFT active matrix type liquid crystal panel 1920x1080 pixels, and diagonal size of 54.6 inch. This module supports Full HD mode (non-interlace).

Each pixel is divided into Red, Green, and Blue sub-pixels or dots which are arranged in vertical stripes. Gray scale or the brightness of the sub-pixel color is determined by 10-bit gray scale signal for each dot.

The P546HW01 V0 has been designed to apply the 10-bit 2-channel LVDS interface method. It is intended to support displays where high brightness, wide viewing angle, and high color depth are important.

The P546HW01 V0 is RoHS verified which can be distinguished on panel label.

◆ General Information

Items	Specification	Unit	Note
Active Screen Size	54.6	inches	Diagonal
Display Area	1209.6 (H) x 680.4 (V)	mm	
Outline Dimension	1286(V) x 745(H) x 60(D)	mm	With inverter
Driver Element	a-Si TFT active matrix		
Display Colors	10 bit(8 bit+FRC), 1073.7M	colors	
Color Gamut	72	%	NTSC
Number of Pixels	1920 x 1080	pixel	
Pixel Arrangement	RGB vertical stripe		
Pixel Pitch	0.63	mm	
Display Mode	Transmissive, Normally Black		
Surface Treatment	AG, 3H		
Life Time (minimum)	50,000	hours	1,2
RoHS	RoHS compliance		
Display Orientation	Portrait/Landscape enable		

Note 1: The life is determined as the time at which luminance of the lamp is 50% compared to that of initial value at the typical lamp current on condition of horizontally continuous operating at 25±2°C.

2: The Lamps are horizontal as the panel is arranged in landscape mode.



Model Name: **P546HW01 V0**
Product Specification

2. Absolute Maximum Ratings

The followings are maximum values which, if exceeded, may cause faulty operation or damage to the unit:

Item	Symbol	Min.	Max	Unit	Note
Logic/LCD Drive Voltage	VDD	-0.3	14	VDC	1
Input Voltage of Signal	Vin	-0.3	4	VDC	1
BLU Input Voltage	VDDDB	-0.3	28	VDC	1
BLU Brightness Control Voltage	VBLON	+2	7	VDC	1
Operating Temperature	T _{OP}	0	+50	°C	2
Operating Humidity	H _{OP}	10	90	%RH	2
Storage Temperature	T _{ST}	-20	+60	°C	2
Storage Humidity	H _{ST}	10	90	%RH	2

Note 1: If operate over spec but under absolute maximum rating, duration must be < 50ms.

Note 2: Maximum Wet-Bulb should be 39°C and no condensation. The relative humidity must not exceed 80% non-condensing at temperatures of 40°C or less. At temperatures greater than 40°C, the wet bulb temperature must not exceed 39°C. When operate at low temperatures, the brightness of CCFL will drop and the life time of CCFL will be reduced.

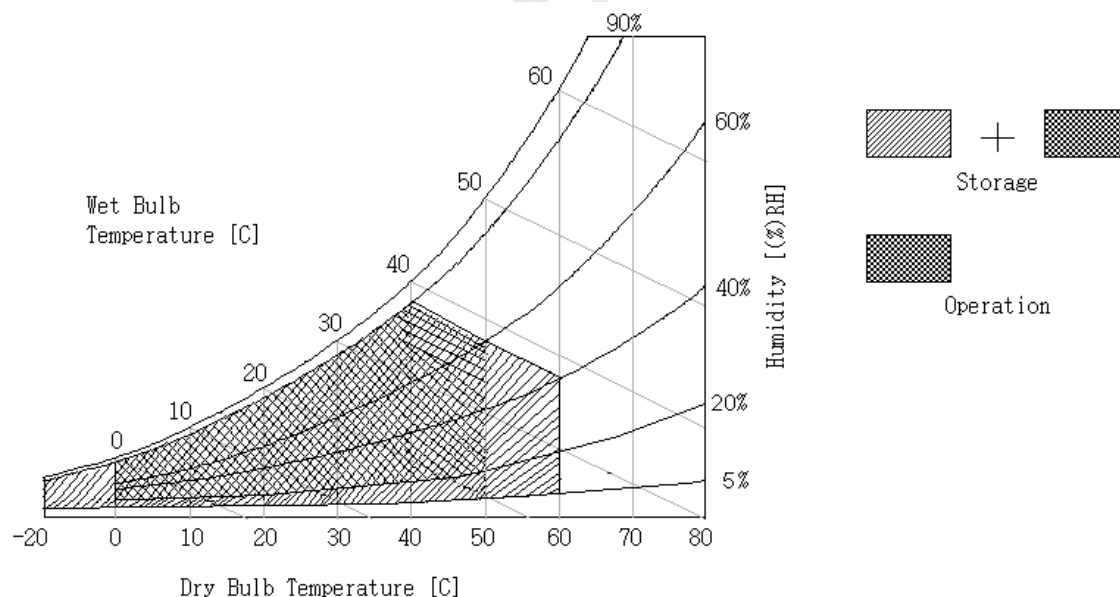

Model Name: **P546HW01 V0**

Product Specification

3. Electrical Specification

The P546HW01 V0 requires two power inputs. One is employed to power the LCD electronics and to drive the TFT array and liquid crystal. The second input which powers the CCFL, is typically generated by an inverter.

3.1 Signal Electrical Characteristics

3.1.1. LCD Character

Parameter		Symbol	Value			Unit	Note
			Min.	Typ.	Max		
LCD							
Power Supply Input Voltage		V_{DD}	10.8	12	13.2	V_{DC}	
Power Supply Input Current		I_{DD}	--	0.5	1.1	A	1
Power Consumption		P_C	--	6	13.2	Watt	1
Inrush Current		I_{RUSH}	--	--	6	A	2
LVDS Interface	Input Differential Voltage	$ V_{ID} $	200	400	600	mV_{DC}	3
	Differential Input High Threshold Voltage	V_{TH}	+100	--	+300	mV_{DC}	3
	Differential Input Low Threshold Voltage	V_{TL}	-300	--	-100	mV_{DC}	3
	Input Common Mode Voltage	V_{ICM}	1.1	1.25	1.4	V_{DC}	3
CMOS Interface	Input High Threshold Voltage	V_{IH} (High)	2.7	--	3.3	V_{DC}	5
	Input Low Threshold Voltage	V_{IL} (Low)	0	--	0.6	V_{DC}	5
Backlight Power Consumption		P_{BL}	-	260	-	W	



3.1.2. Backlight Characteristics

Item	Symbol	Condition	Spec			Unit	Note	
			Min	Typ	Max			
Input Voltage	V_{DDB}	-	21.6	24	26.4	VDC	-	
Input Current	I_{DDB}	VDDDB=24V	9.72	10.8	11.88	ADC	1	
Input Power	P_{DDB}	VDDDB=24V	233	260	285	W	1	
Inrush Current	I_{RUSH}	VDDDB=24V	-	-	14	ADC	2	
Operating Frequency	FBL	VDDDB=24V	53	55	57	KHz		
On/Off control voltage	V_{BLON}	ON	VDDDB=24V	2	-	5.5	VDC	-
		OFF		0	-	0.8		-
On/Off control current	I_{BLON}	VDDDB=24V	-	-	1.5	mA	-	
Internal PWM Dimming Control Voltage	V_{IPWM}	MAX	VDDDB=24V	3.0	-	3.3	VDC	-
		MIN		-	0	-	VDC	-
Internal PWM Dimming Control Current	I_{IPWM}	VDDDB=24V	-	-	2	mADC	-	
Internal PWM Dimming Ratio	R_{IPWM}	VDDDB=24V	10	-	100	%		
External PWM Control Voltage	V_{EPWM}	MAX	VDDDB=24V	2	-	3.3	VDC	-
		MIN	VDDDB=24V	0	-	0.8		-
External PWM Control Current	I_{EPWM}	VDDDB=24V	-	-	2	mADC	-	
External PWM Duty ratio	D_{EPWM}	VDDDB=24V	10	-	100	%	3	
External PWM Frequency	F_{EPWM}	VDDDB=24V	140	180	240	Hz	-	

Do not attach a conducting tape to lamp connecting wire. If the lamp wire attach to conducting tape, TFT-LCD Module have a low luminance and the inverter has abnormal action because leakage current occurs between lamp wire and conducting tape.

The relative humidity must not exceed 80% non-condensing at temperature of 40°C or less. At temperature greater than 40°C, the wet bulb temperature must not exceed 39°C. When operate at low temperature, the brightness of CCFL will drop and the lifetime of CCFL will be reduced.

Note :

1. Vdd=12.0V, fv=60Hz, fCLK=82Mhz , 25°C, Vdd Duration time= 500 μs , Test pattern : white pattern
2. The Backlight power consumption shown above does include loss of external inverter at 25°C . The used

lamp current is the lamp typical current

3. The life is determined as the time at which luminance of the lamp is 50% compared to that of initial value at the typical lamp current on condition of continuous operating at $25\pm 2^{\circ}\text{C}$.
4. $V_{\text{CIM}} = 1.25\text{V}$

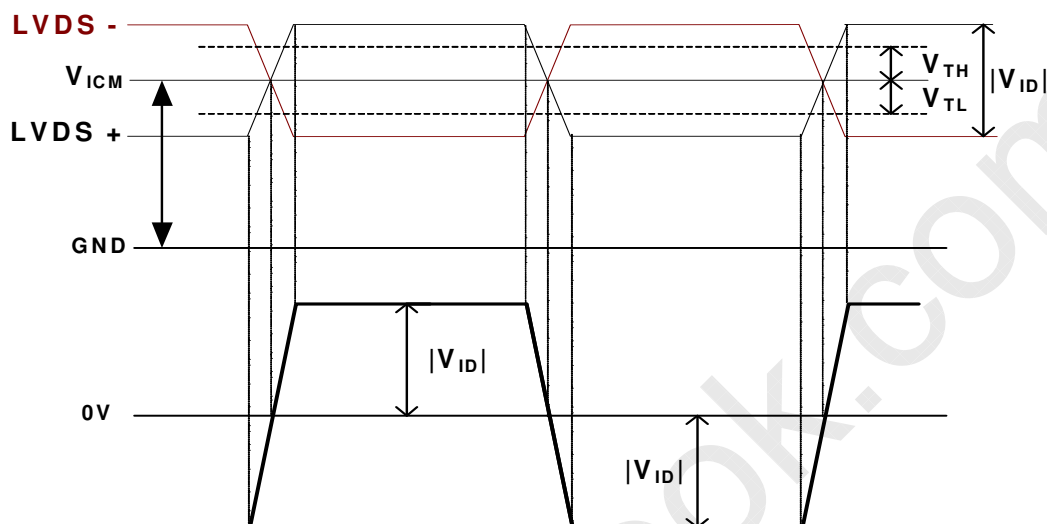

5. Measurement Condition: Rising time = $400\mu\text{s}$

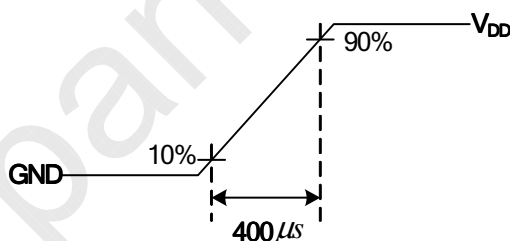

Model Name: **P546HW01 V0**

Product Specification

Signal Interface Connections

◆ LCD LVDS connector (51pin): JAE FI-RE51S-HF

PIN #	Signal Name	Description	PIN #	Signal Name	Description
1	VCC	12V Power Supply	28	RXEP1	LVDS Even pixel data input pair 1(+)
2	VCC	12V Power Supply	29	RXEN2	LVDS Even pixel data input pair 2(-)
3	VCC	12V Power Supply	30	RXEP2	LVDS Even pixel data input pair 2(+)
4	VCC	12V Power Supply	31	GND	GND
5	VCC	12V Power Supply	32	RXENCLK	LVDS Even pixel clock input pair(-)
6	GND	GND	33	RXEPCLK	LVDS Even pixel clock input pair(+)
7	GND	GND	34	GND	GND
8	GND	GND	35	RXEN3	LVDS Even pixel data input pair 3(-)
9	GND	GND	36	RXEP3	LVDS Even pixel data input pair 3(+)
10	RXON0	LVDS Odd pixel data input pair 0(-)	37	RXEN4	LVDS Even pixel data input pair 4(-)
11	RXOP0	LVDS Odd pixel data input pair 0(+)	38	RXEP4	LVDS Even pixel data input pair 4(+)
12	RXON1	LVDS Odd pixel data input pair 1(-)	39	GND	GND
13	RXOP1	LVDS Odd pixel data input pair 1(+)	40	Reserved	AUO Internal Use Only
14	RXON2	LVDS Odd pixel data input pair 2(-)	41	Reserved	AUO Internal Use Only
15	RXOP2	LVDS Odd pixel data input pair 2(+)	42	NC	No connected
16	GND	GND	43	NC	No connected
17	RXONCLK	LVDS Odd pixel clock input pair(-)	44	NC	No connected
18	RXOPCLK	LVDS Odd pixel clock input pair(+)	45	LVDSORD	Select LVDS data order:
19	GND	GND			● High or NC → NS
20	RXON3	LVDS Odd pixel data input pair 3(-)			● Low → JEIDA
21	RXOP3	LVDS Odd pixel data input pair 3(+)	46	NC	No connected
22	RXON4	LVDS Odd pixel data input pair 4(-)	47	NC	No connected
23	RXOP4	LVDS Odd pixel data input pair 4(+)	48	NC	No connected
24	GND	GND	49	Reserved	AUO Internal Use Only
25	RXEN0	LVDS Even pixel data input pair 0(-)	50	Reserved	AUO Internal Use Only
26	RXEP0	LVDS Even pixel data input pair 0(+)	51	Reserved	AUO Internal Use Only
27	RXEN1	LVDS Even pixel data input pair 1(-)			



The 10 bits LVDS Input Data Mapping

- JEIDA mode LVDS Input (LVDSORD = Low)

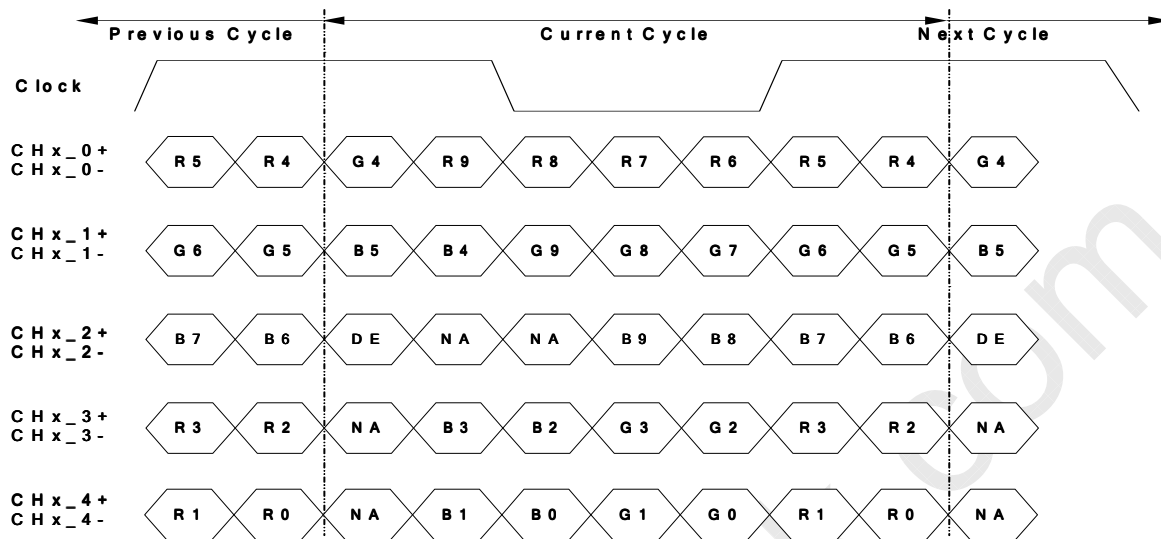

Note: x = 1, 2, 3, 4...

- NS-like mode LVDS Input (LVDSORD = High or NC)

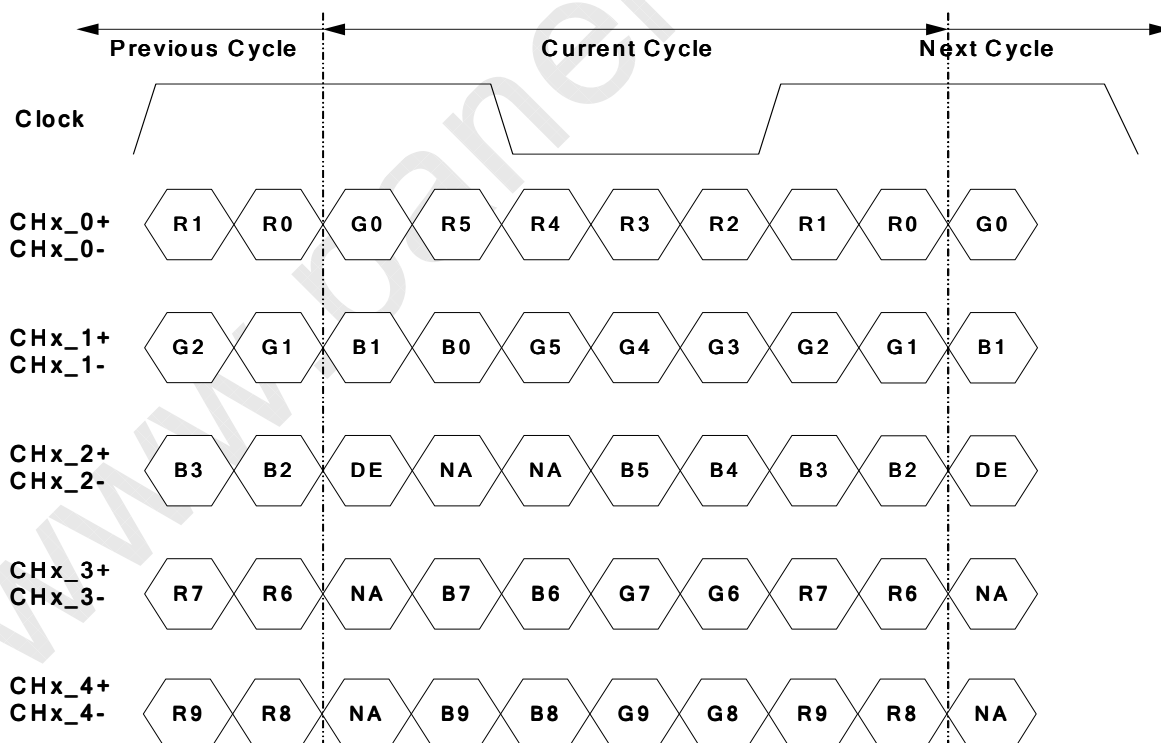

Note: x = 1, 2, 3, 4...



Model Name: **P546HW01 V0**
Product Specification

The 8 bits LVDS Input Data Mapping

- LVDS Option = Low → JEIDA

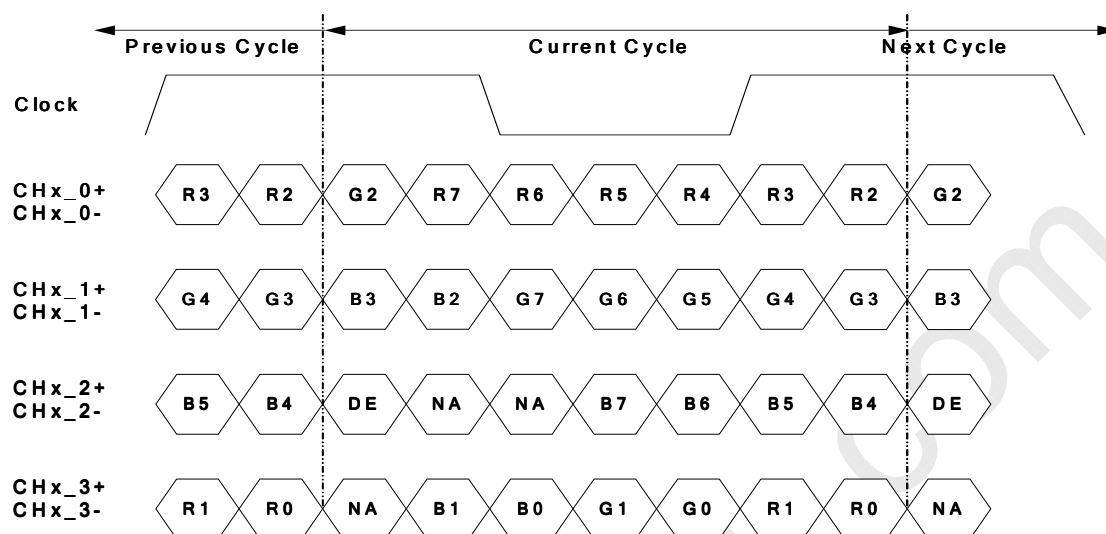

Note: x = 1, 2, 3, 4...

Note : For 8 bit LVDS input application, Panel only can be operated under JEIDA mode.



Backlight Connector Pin Configuration

1. Input specification

Connector Master: CI0114S00L0 (Cvilux) or equivalent

Pin	Symbol	Description
1	VDDDB	Operating Voltage Supply, +24V DC regulated
2	VDDDB	Operating Voltage Supply, +24V DC regulated
3	VDDDB	Operating Voltage Supply, +24V DC regulated
4	VDDDB	Operating Voltage Supply, +24V DC regulated
5	VDDDB	Operating Voltage Supply, +24V DC regulated
6	BLGND	Ground and Current Return
7	BLGND	Ground and Current Return
8	BLGND	Ground and Current Return
9	BLGND	Ground and Current Return
10	BLGND	Ground and Current Return
11	DET	BLU status detection: Normal : 0~0.8V ; Abnormal : Open collector
12	VBLON	BLU On-Off control: BL On : High/Open (2V~5.5V); BL off : Low (0~0.8V/GND)
13	VDIM	Internal PWM (0~3.3V for 10~100% Duty, open for 100%) < NC ; at External PWM mode>
14	PDIM	External PWM (10%~100% Duty, open for 100%) < NC ; at Internal PWM mode>

Note 1 :

Dimming ratio= 100% (MAX) (Ta=25±5°C, Turn on for 45minutes)

Note 2 : IF External PWM function includes 5% dimming function. Judge condition is shown below:

- 1.) Backlight module must be lighted ON normally.
- 2.) All protection function must operate normally.
- 3.) Uniformity and flicker could NOT be guaranteed!

When External or Internal PWM working Duty ratio is above 20%, all function condition MUST be in SPEC.

- 4) In Product SPEC Description, Inverter will NOT guarantee optical performance when Dimming ratio under 20%; and NOT guarantee Protection function when Dimming ratio under 5%.



Model Name: **P546HW01 V0**
Product Specification

Connector Slave: S12B-PH-SM4-TB (JST) or equivalent

Pin No	Symbol	Description
1	VDDB	Operating Voltage Supply, +24V DC regulated
2	VDDB	Operating Voltage Supply, +24V DC regulated
3	VDDB	Operating Voltage Supply, +24V DC regulated
4	VDDB	Operating Voltage Supply, +24V DC regulated
5	VDDB	Operating Voltage Supply, +24V DC regulated
6	BLGND	Ground and Current Return
7	BLGND	Ground and Current Return
8	BLGND	Ground and Current Return
9	BLGND	Ground and Current Return
10	BLGND	Ground and Current Return
11	NC	NC
12	NC	NC
13	NC	NC
14	NC	NC

3.2. Signal Timing Specification

This is the signal timing required at the input of the user connector. All of the interface signal timing should be satisfied with the following specifications for its proper operation.

Vertical Frequency Range (60Hz)

Timing Table (DE only Mode)

Signal	Item	Symbol	Min.	Typ.	Max	Unit
Vertical Section	Period	Tv	1090	1125	1480	Th
	Active	Tdisp (v)	1080			Th
	Blanking	Tblk (v)	10	45	400	Th
Horizontal Section	Period	Th	1030	1100	1325	Tclk
	Active	Tdisp (h)	960			Tclk
	Blanking	Tblk (h)	70	140	365	Tclk
Clock	Frequency	Fclk=1/Tclk	50	74.25	82	MHz
Vertical Frequency	Frequency	Fv	47	60	63	Hz
Horizontal Frequency	Frequency	Fh	60	67.5	73	KHz



Model Name: **P546HW01 V0**
Product Specification

3.3. Signal Timing Waveform

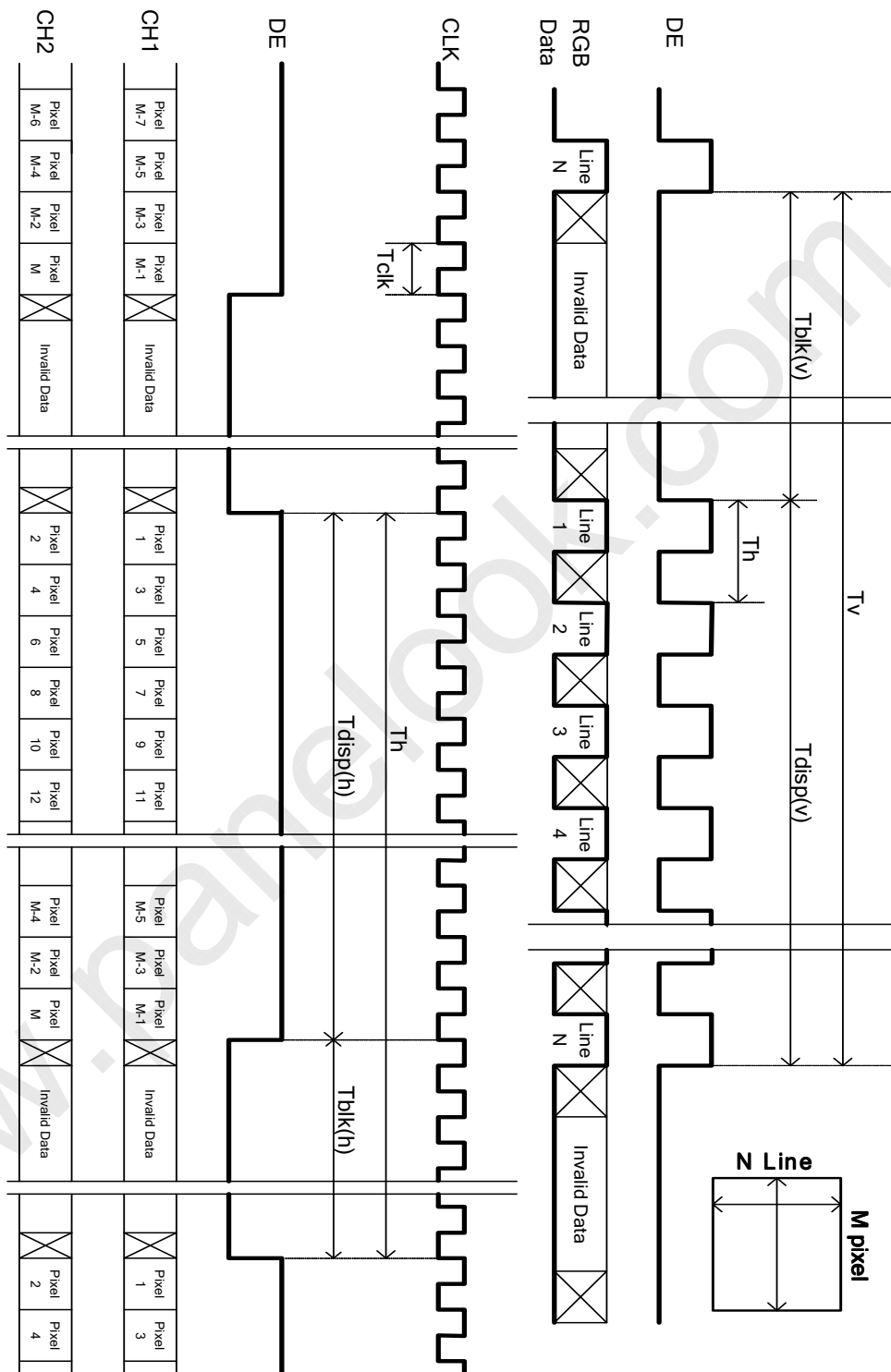



3.4. Color Input Data Reference

The brightness of each primary color (red, green, and blue) is based on the 10-bit gray scale data input for the color; the higher the binary input, the brighter the color. The table below provides a reference for color versus data input.

COLOR DATA REFERENCE

Color		Input Color Data																													
		RED										GREEN										BLUE									
		MSB					LSB					MSB					LSB					MSB					LSB				
		R9	R8	R7	R6	R5	R4	R3	R2	R1	R0	G9	G8	G7	G6	G5	G4	G3	G2	G1	G0	B9	B8	B7	B6	B5	B4	B3	B2	B1	B0
Basic Color	Black	0	0	0	0	0	0	0	0	0	0	0	0	0	0	0	0	0	0	0	0	0	0	0	0	0	0	0	0	0	0
	Red(1023)	1	1	1	1	1	1	1	1	1	1	0	0	0	0	0	0	0	0	0	0	0	0	0	0	0	0	0	0	0	0
	Green(1023)	0	0	0	0	0	0	0	0	0	0	1	1	1	1	1	1	1	1	1	1	0	0	0	0	0	0	0	0	0	0
	Blue(1023)	0	0	0	0	0	0	0	0	0	0	0	0	0	0	0	0	0	0	0	0	1	1	1	1	1	1	1	1	1	1
	Cyan	0	0	0	0	0	0	0	0	0	0	1	1	1	1	1	1	1	1	1	1	1	1	1	1	1	1	1	1	1	1
	Magenta	1	1	1	1	1	1	1	1	1	1	0	0	0	0	0	0	0	0	0	0	1	1	1	1	1	1	1	1	1	1
	Yellow	1	1	1	1	1	1	1	1	1	1	1	1	1	1	1	1	1	1	1	1	0	0	0	0	0	0	0	0	0	0
	White	1	1	1	1	1	1	1	1	1	1	1	1	1	1	1	1	1	1	1	1	1	1	1	1	1	1	1	1	1	1
R	RED(000)	0	0	0	0	0	0	0	0	0	0	0	0	0	0	0	0	0	0	0	0	0	0	0	0	0	0	0	0	0	
	RED(001)	0	0	0	0	0	0	0	0	1	0	0	0	0	0	0	0	0	0	0	0	0	0	0	0	0	0	0	0	0	

	RED(1022)	1	1	1	1	1	1	1	1	1	0	0	0	0	0	0	0	0	0	0	0	0	0	0	0	0	0	0	0	0	
	RED(1023)	1	1	1	1	1	1	1	1	1	0	0	0	0	0	0	0	0	0	0	0	0	0	0	0	0	0	0	0	0	
G	GREEN(000)	0	0	0	0	0	0	0	0	0	0	0	0	0	0	0	0	0	0	0	0	0	0	0	0	0	0	0	0	0	
	GREEN(001)	0	0	0	0	0	0	0	0	0	0	0	0	0	0	0	0	0	0	1	0	0	0	0	0	0	0	0	0	0	

	GREEN(1022)	0	0	0	0	0	0	0	0	0	1	1	1	1	1	1	1	1	1	0	0	0	0	0	0	0	0	0	0	0	
	GREEN(1023)	0	0	0	0	0	0	0	0	0	1	1	1	1	1	1	1	1	1	1	0	0	0	0	0	0	0	0	0	0	
B	BLUE(000)	0	0	0	0	0	0	0	0	0	0	0	0	0	0	0	0	0	0	0	0	0	0	0	0	0	0	0	0	0	
	BLUE(001)	0	0	0	0	0	0	0	0	0	0	0	0	0	0	0	0	0	0	0	0	0	0	0	0	0	0	0	0	1	

	BLUE(1022)	0	0	0	0	0	0	0	0	0	0	0	0	0	0	0	0	0	0	0	1	1	1	1	1	1	1	1	1	0	
	BLUE(1023)	0	0	0	0	0	0	0	0	0	0	0	0	0	0	0	0	0	0	0	1	1	1	1	1	1	1	1	1	1	



Model Name: **P546HW01 V0**
Product Specification

3.5. Power Sequence

◆ Power Sequence of LCD

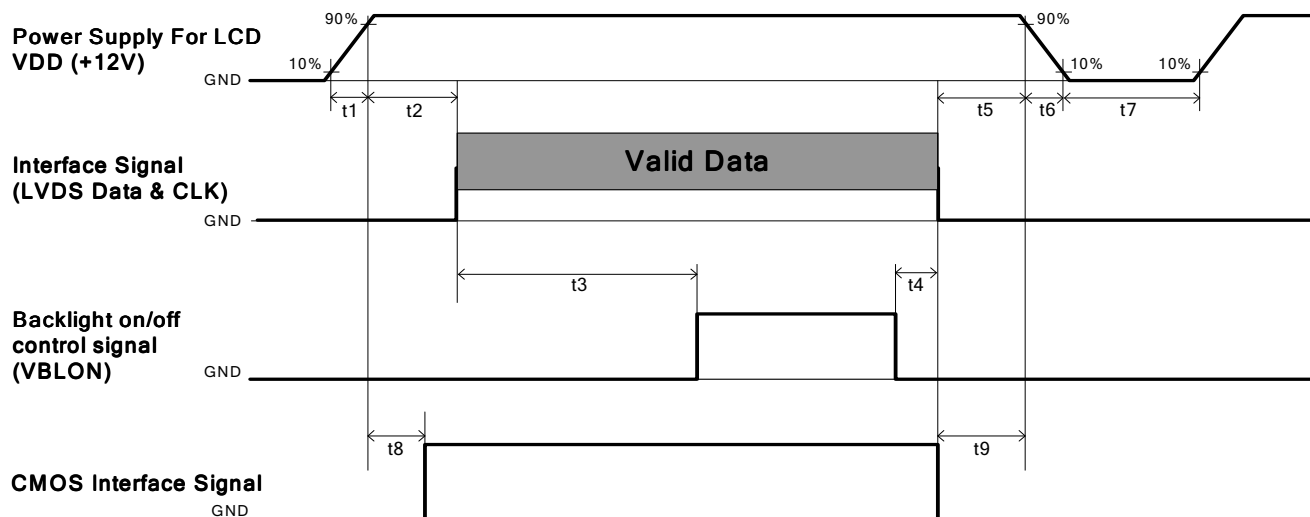

Parameter	Values			Unit
	Min.	Type.	Max.	
t1	0.4	---	30	ms
t2	0.1	---	50	ms
t3	450	---	---	ms
t4	0 ^{*1}	---	---	ms
t5	0	---	---	ms
t6	---	---	---	ms
t7	500	---	---	ms
t8	10	---	50	ms
t9	0	---	---	ms

*: If t3=200ms, input black signal till 700ms from system is necessary. In case of t3<200ms, the abnormal display will be happened. But it will not damage timing controller.

Apply the lamp voltage within the LCD operating range. When the backlight turns on before the LCD operation or the LCD turns off before the backlight turns off, the display may momentarily become abnormal.

Caution: The above on/off sequence should be applied to avoid abnormal function in the display. In case of handling, make sure to turn off the power when you plug the cable into the input connector or pull the cable out of the connector.

Model Name: **P546HW01 V0**

Product Specification

◆ Power Sequence of Inverter

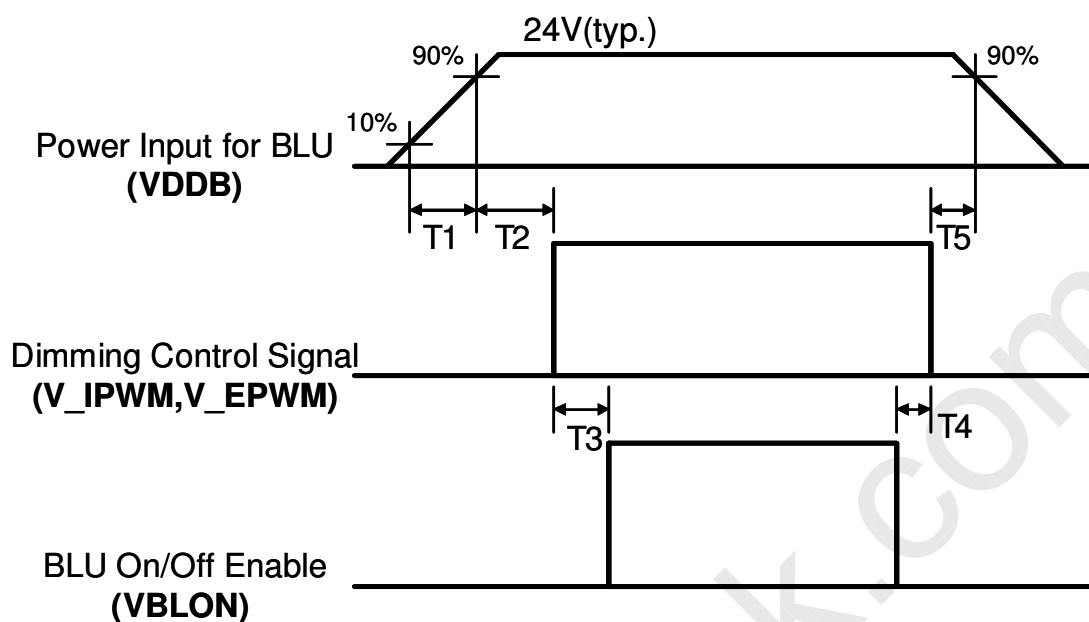

Dip condition for Inverter

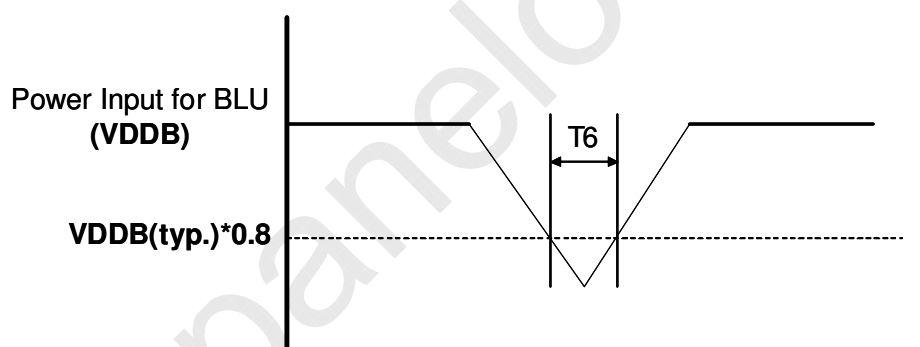

Parameter	Value			Units
	Min	Typ	Max	
T1	20	-	-	ms
T2	500	-	-	ms
T3	250	-	-	ms
T4	0	-	-	ms
T5	1	-	-	ms
T6	-	-	10	ms

4. Optical Specification

Optical characteristics are determined after the unit has been 'ON' and stable for approximately 60 minutes in a dark environment at 25°C. The values specified are at an approximate distance 50cm from the LCD surface at a viewing angle of φ and θ equal to 0°.

Test condition:

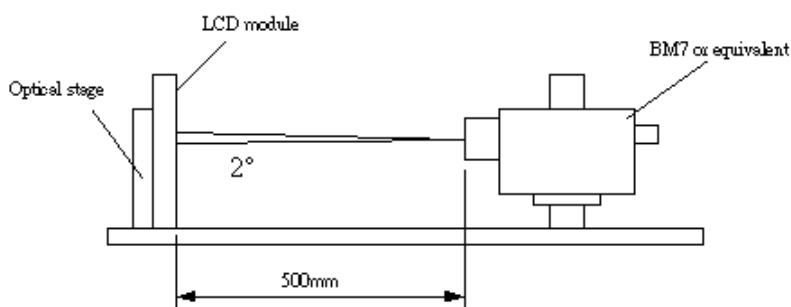

($T_a=25\pm 5^\circ\text{C}$, Turn-on after 60mins)

Parameter	Symbol	Values			Unit	Notes
		Min.	Typ.	Max		
Contrast Ratio	CR	4000	5000	--		1
Surface Luminance (White)	L_{WH}	400	500	--	cd/m^2	2
Luminance Variation	$\delta_{WHITE(9P)}$	--	--	1.3		3
Response Time (Average)	T_R	--	8	--	ms	5 (Gray to Gray)
Rising Time	T_r		15	25	ms	4
Falling Time	T_f		8	10	ms	4
Color Coordinates						
Red	R_x	Typ.-0.03	0.640	Typ.+0.03		
	R_y		0.330			
Green	G_x		0.290			
	G_y		0.600			
Blue	B_x		0.150			
	B_y		0.060			
White	W_x	0.28				
	W_y	0.29				
Viewing Angle						(Contrast Ratio>10)
x axis, right($\varphi=0^\circ$)	θ_r	--	89	--	degree	6
x axis, left($\varphi=180^\circ$)	θ_l	--	89	--	degree	6
y axis, up($\varphi=90^\circ$)	θ_u	--	89	--	degree	6
y axis, down ($\varphi=270^\circ$)	θ_d	--	89	--	degree	6

Note:

1. Contrast Ratio (CR) is defined mathematically as:

$$\text{Contrast Ratio(CR)} = \frac{\text{Surface Luminance with all "white" pixels}}{\text{Surface Luminance with all "black" pixels}}$$

2. Surface luminance is luminance value at point 1 across the LCD surface 50cm from the surface with all pixels displaying white. From more information see Fig. 4-2. When $V_{DDB} = 24V$, $I_{DDB} = 12.5 A$. $L_{WH} = L_{on1}$, Where L_{on1} is the luminance with all pixels displaying white at center 1 location.

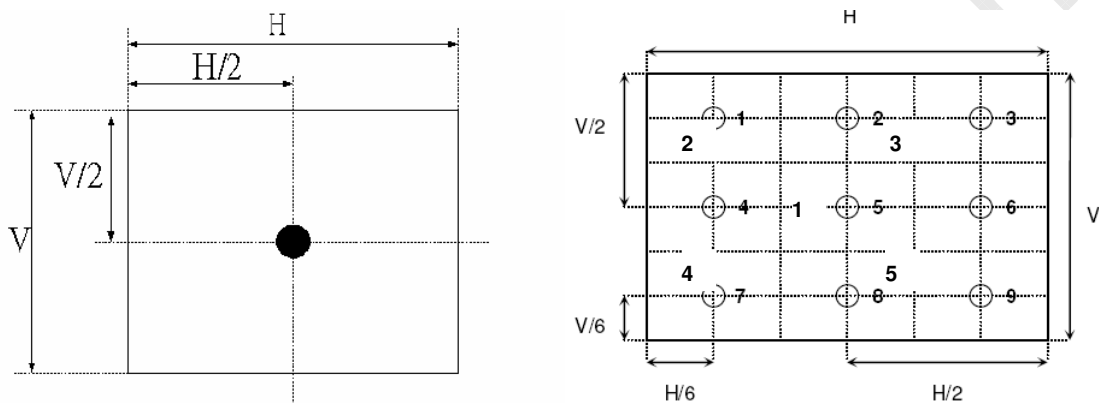

Fig.4-2 Optical measurement point

3. The variation in surface luminance, δ_{WHITE} is defined under 100% brightness as:

$$\delta_{WHITE(P)} = \text{Maximum}(L_{on1}, L_{on2}, \dots, L_{on^9}) / \text{Minimum}(L_{on1}, L_{on2}, \dots, L_{on^9})$$

4. Response time is the time required for the display to transition from white(L255) to black(L0) (Decay Time, $Tr_D = T_f$) and from black(L0) to white(L255) (Rise Time, $Tr_R = T_r$). For additional information see Fig. 4-3.

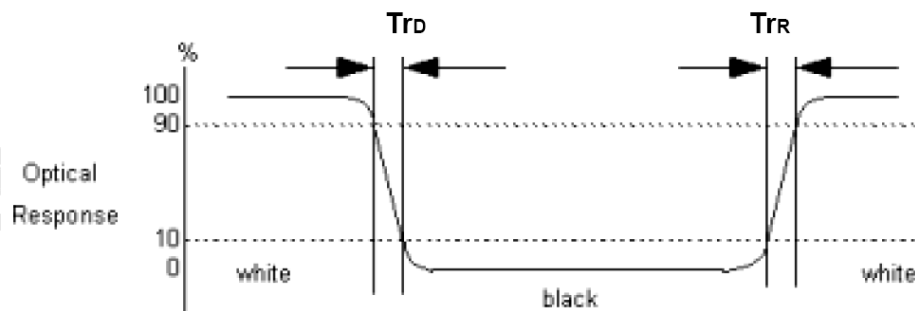

Fig.4-3 Response time

5. The response time is defined as the following figure and shall be measured by switching the input signal among 0%, 25%, 50%, 75%, 100% luminance. For additional information see Fig. 4-4.

	0%	25%	50%	75%	100%
0%		t: 0%-25%	t: 0%-50%	t: 0%-75%	t: 0%-100%
25%	t: 25%-0%		t: 25%-50%	t: 25%-75%	t: 25%-100%
50%	t: 50%-0%	t: 50%-25%		t: 50%-75%	t: 50%-100%
75%	t: 75%-0%	t: 75%-25%	t: 75%-50%		t: 75%-100%
100%	t: 100%-0%	t: 100%-25%	t: 100%-50%	t: 100%-75%	

Fig.4-4 Response time

6. Viewing angle is the angle at which the contrast ratio is greater than 10. The angles are determined for the horizontal or x axis and the vertical or y axis with respect to the z axis which is normal to the LCD surface. For more information see Fig. 4-5. (Optical measurement by SR3)

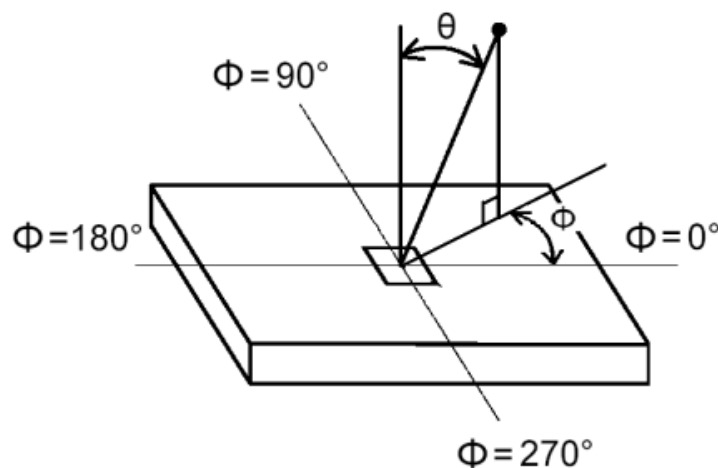

Fig.4-5 Viewing Angle Definition

5. Mechanical Characteristics

The contents provide general mechanical characteristics for the model P520HW01 V0. Detailed mechanical drawings are shown in the following pages.

Outline Dimension	Horizontal (typ.)	1286 mm
	Vertical (typ.)	745 mm
	Depth (typ.)	60 mm (with inverter)
Bezel Opening Area	Horizontal (typ.)	1217.6 mm
	Vertical (typ.)	688 mm
Active Display Area	Horizontal	1209.6 mm
	Vertical	680.4 mm
Weight	20,500 g (typ)	

5.1. Placement suggestions:

The Suggestion placement is as following:

1. Landscape mode: The T-con side has to be placed as the upper side.
2. Portrait mode: The T-con side has to be placed as the left side.

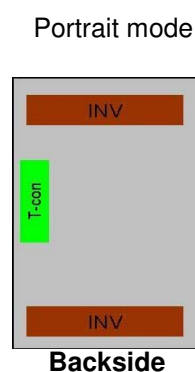
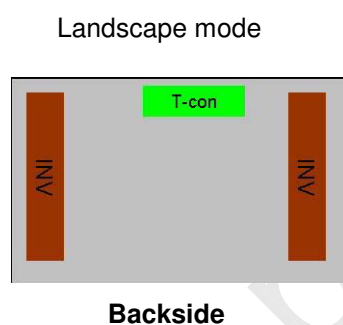



Model Name: **P546HW01 V0**
Product Specification

2D Drawing (Front)

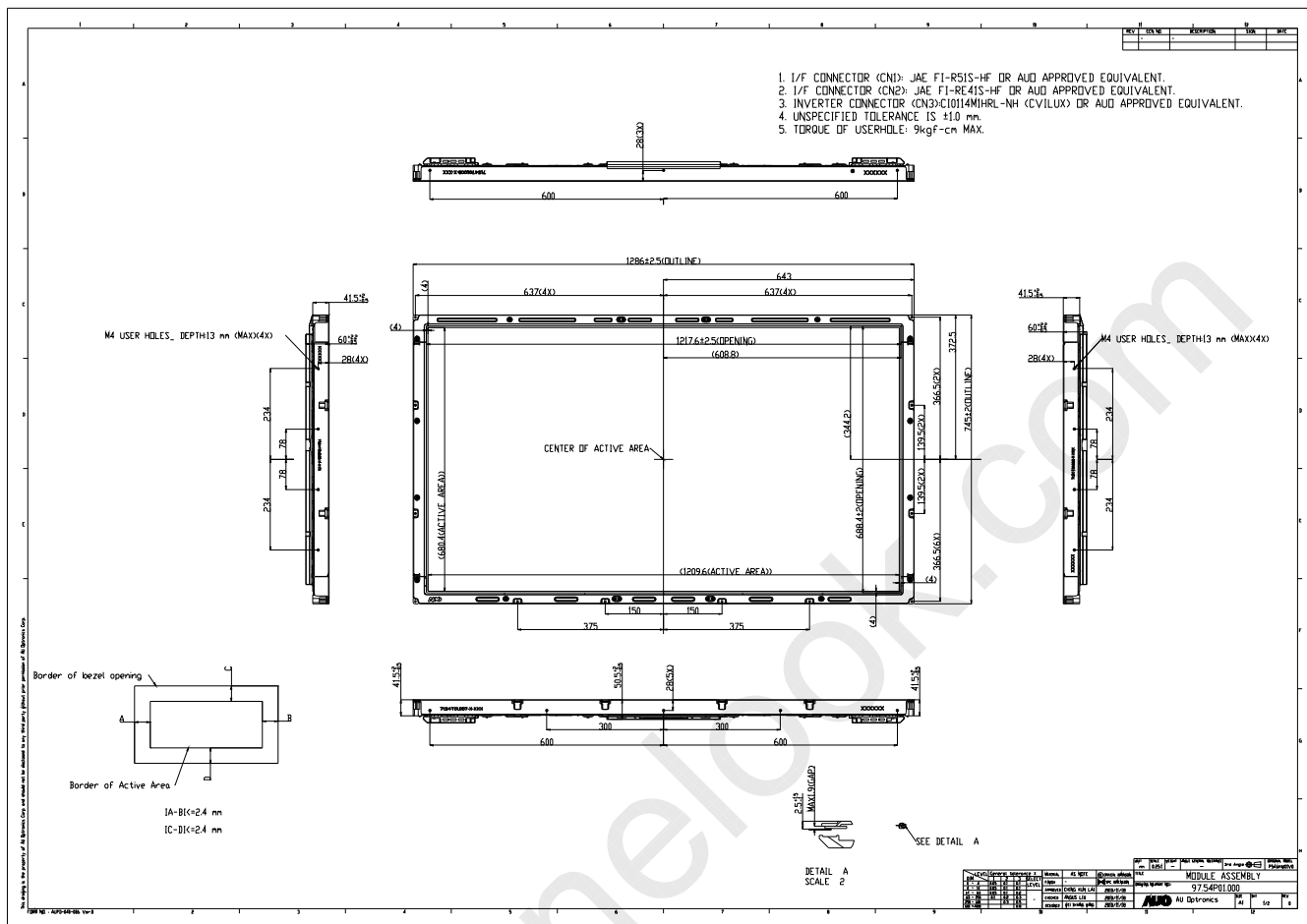



2D Drawing (Rear)

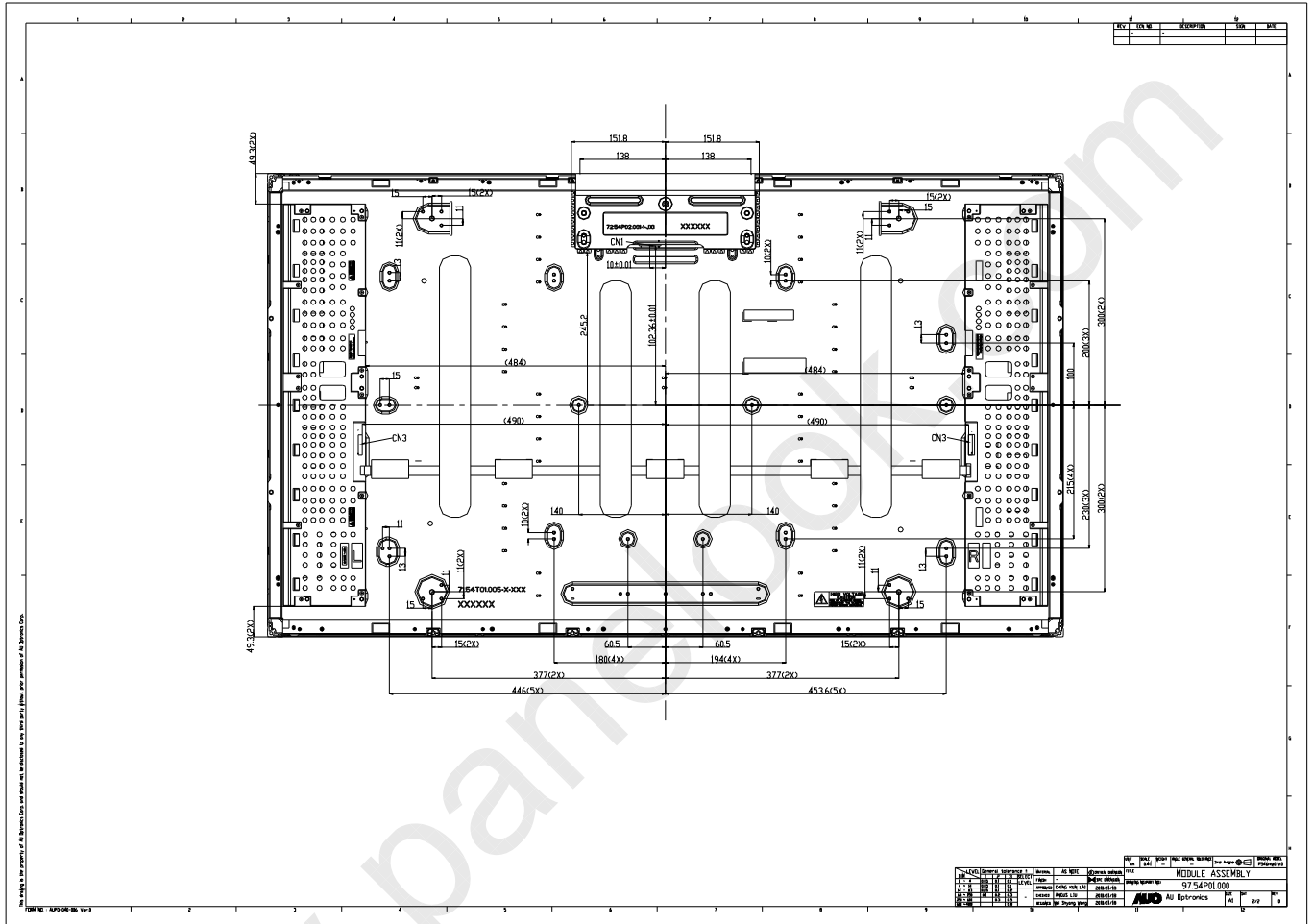



6. Reliability Test

No	Test Item	Condition
1	High temperature storage test	Ta=60°C, 500hr judge
2	Low temperature storage test	Ta=-20°C, 500hr judge
3	High temperature/High humidity operation test	Ta=50°C, 80%RH, 500hr judge
4	High temperature operation test	Ta=50°C, 500hr judge
5	Low temperature operation test	Ta=-5°C, 500hr judge
6	Thermal shock	-20°C/0.5hr ~ 60°C/0.5hr, 100cycle
7	Vibration test (non-operating)	Wave form: Random Vibration level: 1.5G RMS, Bandwidth: 10-500Hz Duration: X, Y, Z (30min one time each direction)
8	Shock test (non-operating)	Shock level: 30G Waveform: half sine wave, 11ms Direction: ±X, ±Y, ±Z (One time each direction)
9	Vibration test (with carton)	Wave form: Random Vibration level: 1.5G RMS, Bandwidth: 10~200Hz Duration: X, Y, Z (30min each direction)
10	Drop test (with carton)	Height: 25.4cm 6 surfaces (ASTMD4169-I)



7. International Standard

7.1. Safety

- (1) UL60065,2003, Underwriters Laboratories, Inc. (AUO file number : E204356)
Audio, video and similar electronic apparatus, safety requirement
- (2) UL60950-1,2003, Underwriters Laboratories, (AUO file number : E204356)
Standard for safety of information technology equipment including electrical business equipment
- (3) EN60065
- (4) EN60950
- (5) IEC 60065, European Committee for Electro technical Standardization (CENELEC)
Audio, video and similar electronic apparatus, safety requirement
- (6) IEC 60950-1:
European Committee for Electrotechnical Standardization (CENELEC)
European Standard for safety of information technology equipment including electrical business equipment

7.2. EMC

- (1) ANSI C63.4 "Methods of Measurement of Radio-Noise Emissions from Low-Voltage Electrical and Electrical Equipment in the Range of 9kHz to 40GHz. "American National standards Institute(ANSI), 1992
- (2) C.I.S.P.R "Limits and Methods of Measurement of Radio Interface Characteristics of Information Technology Equipment." International Special committee on Radio Interference.
- (3) EN 55022 "Limits and Methods of Measurement of Radio Interface Characteristics of Information Technology Equipment." European Committee for Electrotechnical Standardization. (CENELEC), 1998



Model Name: **P546HW01 V0**
Product Specification

8. Packing

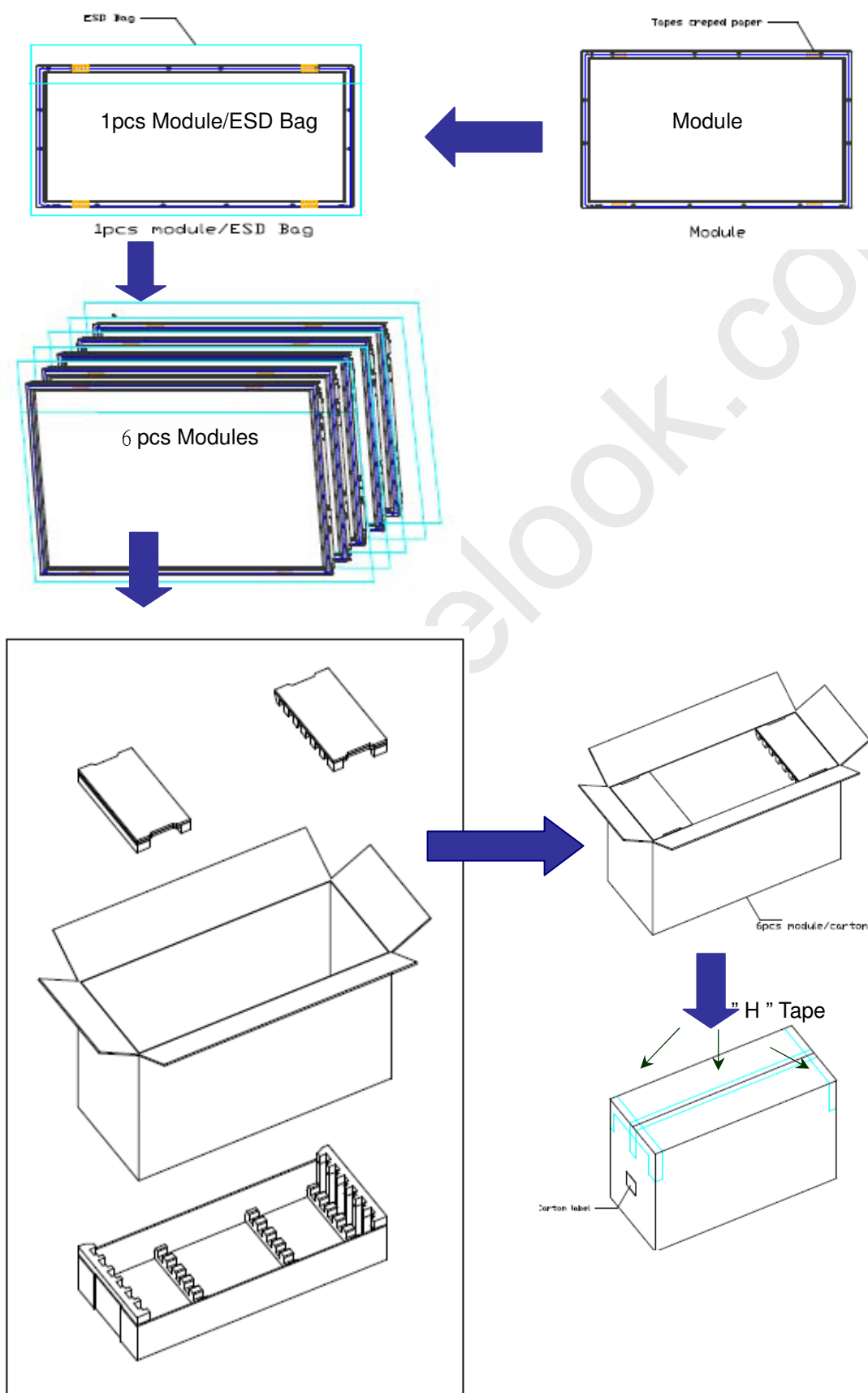



Model Name: **P546HW01 V0**
Product Specification

Package Information:

Carton outside dimension: 1355(L)mm× 560(W)mm× 830(H)mm

Carton/Package with EPE Cushion : 11.0 Kg

Gross weight (per Box): 134.0 kg

Shipping Label (on the rear side of TFT-LCD display)



Green Mark Description:

For Pb Free products, AUO will add  for identification.

For RoHS compatible products, AUO will add  for identification.

Note: The Green Mark will be present only when the green documents have been ready by AUO Internal Green Team. (The definition of green design follows the AUO green design checklist.)

Carton label

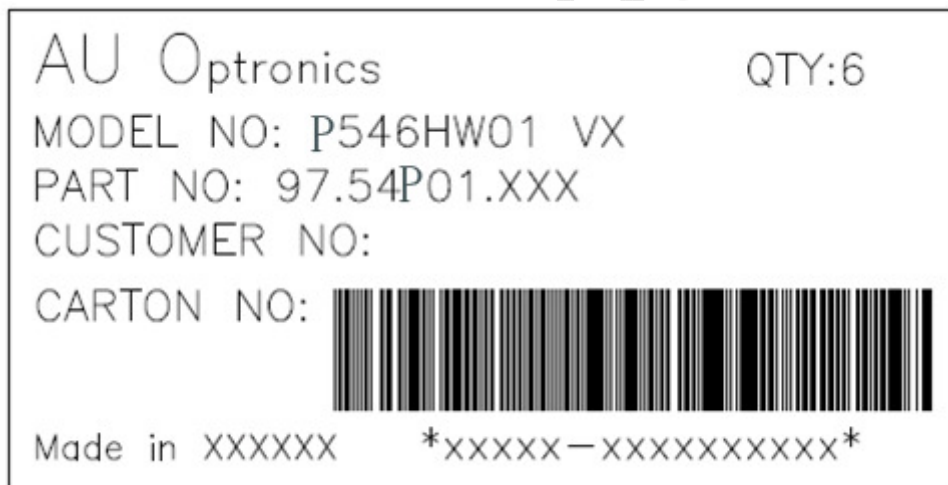

Pallet Information

By air cargo: : (2x1) x1 layers, one pallet put 2 boxes, total 12 pcs module.

By sea: (2x1) x2 layers, one pallet put 2 boxes, stock 2 layer, total 24 pcs module.

Pallet dimension : 1390 m m× 1150 m m *132 m m

Pallet weight: 15.5kg

By air total weight: 134 kg/box X 2 boxes=268 kg (with pallet weight 283.5 kg)

By sea total weight: 134 kg/box X 4 boxes=536 kg (with pallet weight 567 kg)



Model Name: **P546HW01 V0**
Product Specification

By air:

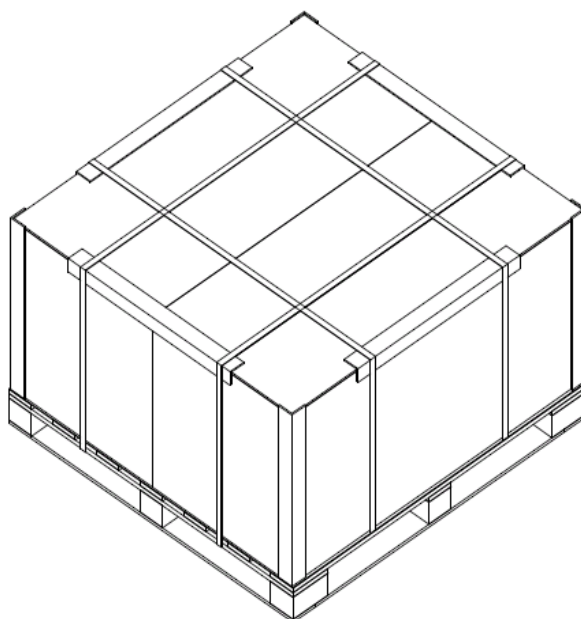

By Sea:

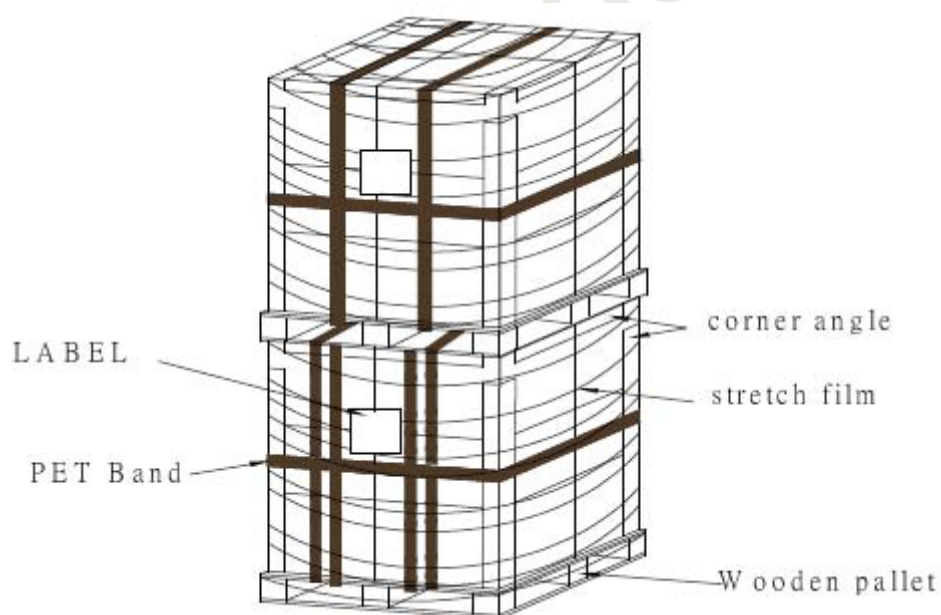

9. Precautions

Please pay attention to the followings when you use this TFT LCD module.

9.1. MOUNTING PRECAUTIONS

- (1) You must mount a module using holes arranged on back or edge side of panel.
- (2) You should consider the mounting structure so that uneven force (ex. twisted stress) is not applied to module. And the case on which a module is mounted should have sufficient strength so that external



force is not transmitted directly to the module.

- (3) Please attach the surface transparent protective plate to the surface in order to protect the polarizer. Transparent protective plate should have sufficient strength in order to resist external force.
- (4) You should adopt radiation structure to satisfy the temperature specification.
- (5) Acetic acid type and chlorine type materials for the cover case are not desirable because the former generates corrosive gas of attacking the polarizer at high temperature and the latter cause circuit break by electro-chemical reaction.
- (6) Do not touch, push or rub the exposed polarizer with glass, tweezers or anything harder than HB pencil lead. And please do not rub with dust clothes with chemical treatment. Do not touch the surface of polarizer for bare hand or greasy cloth. (Some cosmetics are detrimental to the polarizer.)
- (7) When the surface becomes dusty, please wipe gently with absorbent cotton or other soft materials like chamois soaks with petroleum benzene. Normal-hexane is recommended for cleaning the adhesives used to attach front/rear polarizer. Do not use acetone, toluene and alcohol because they cause chemical damage to the polarizer.
- (8) Wipe off saliva or water drops as soon as possible. Their long time contact with polarizer causes deformations and color fading.
- (9) Do not open the case because inside circuits do not have sufficient strength.

9.2. OPERATING PRECAUTIONS

- (1) The spike noise causes the mis-operation of circuits. It should be lower than following voltage:
 $V = \pm 200\text{mV}$ (over and under shoot voltage)
- (2) Response time depends on the temperature. (In lower temperature, it becomes longer.)
- (3) Brightness of CCFL depends on the temperature. (In lower temperature, it becomes lower.) And in lower temperature, response time (required time that brightness is stable after turned on) becomes longer.
- (4) Be careful for condensation at sudden temperature change. Condensation makes damage to polarizer or electrical contacted parts. And after fading condensation, smear or spot will occur.
- (5) When fixed patterns are displayed for a long time, remnant image is likely to occur.
- (6) Module has high frequency circuits. Sufficient suppression to the electromagnetic interference shall be done by system manufacturers. Grounding and shielding methods may be important to minimize the interface.



9.3. ELECTROSTATIC DISCHARGE CONTROL

Since a module is composed of electronic circuits, it is not strong to electrostatic discharge. Make certain that treatment persons are connected to ground through wrist band etc. And don't touch interface pin directly.

9.4. PRECAUTIONS FOR STRONG LIGHT EXPOSURE

Strong light exposure causes degradation of polarizer and color filter.

9.5. STORAGE

When storing modules as spares for a long time, the following precautions are necessary.

- (1) Store them in a dark place. Do not expose the module to sunlight or fluorescent light. Keep the temperature between 5°C and 35°C at normal humidity.
- (2) The polarizer surface should not come in contact with any other object. It is recommended that they be stored in the container in which they were shipped.

9.6. HANDLING PRECAUTIONS FOR PROTECTION FILM

- (1) The protection film is attached to the bezel with a small masking tape. When the protection film is peeled off, static electricity is generated between the film and polarizer. This should be peeled off slowly and carefully by people who are electrically grounded and with well ion-blown equipment or in such a condition, etc.
- (2) When the module with protection film attached is stored for a long time, sometimes there remains a very small amount of glue still on the Bezel after the protection film is peeled off.
- (3) You can remove the glue easily. When the glue remains on the Bezel or its vestige is recognized, please wipe them off with absorbent cotton waste or other soft material like chamois soaked with normal-hexane.

9.7. Operating Condition in PID Application

- (1) If the continuous static display is required, periodically inserting a motion picture is strongly recommended.
- (2) Recommend to periodically change the background color and background image.
- (3) Recommend not to continuously operate over 18 hours a day.
- (4) Recommend to adopt one of the following actions after long time display.
 - I. Running the screen saver (motion picture or black pattern)
 - II. Power off the system for a while
- (5) Try not to run the LCD in a closed environment. Suitable venting on the system cover would be helpful for cooling.
- (6) It is better to adapt active cooling with fans for long time displaying, especially for high luminance LCD model.