

Version : 1.1

TECHNICAL SPECIFICATION

MODEL NO. : P64CN1

Customer's Confirmation

Customer _____

Date _____

By _____

PVI's Confirmation

Confirmed By _____

Prepared By _____

PRIME VIEW INTERNATIONAL CO.,LTD.
3,LI SHIN RD. 1,SCIENCE-BASED INDUSTRIAL
PARK,HSINCHU,TAIWAN,R.O.C.
<http://www.pvi.com.tw>

Date : Mar. 05,2001

This technical specification is subject to change without notice.
Please return 1 copy with your signature on this page for approval.

TECHNICAL SPECIFICATION

CONTENTS

<i>NO.</i>	<i>ITEM</i>	<i>PAGE</i>
-	Cover(P64CN1)	1
-	Contents	2
1	Application	3
2	Features	3
3	Mechanical Specifications	3
4	Mechanical Drawing of TFT-LCD module	4
5	Input / Output Terminals	5
6	Absolute Maximum Ratings	7
7	Electrical Characteristics	8
8	Optical Characteristics	17
9	Handling Cautions	20
10	Reliability Test	21
11	Indication of Lot Number Label	21
12	Block Diagram	22
13	Packing	23
-	Revision History	24

1. Application

This technical specification applies to 6.4" color TFT-LCD module, P64CN1.

2. Features

- . Compatible with NTSC and PAL system
- . Pixel in stripe configuration
- . Slim and compact
- . Active area / Outline area = 67.9 %
- . Aperture Ratio : 60 %
- . Viewing Direction : 6 o'clock

3. Mechanical Specifications

Parameter	Specifications	Unit
Screen Size	6.4 (diagonal)	inch
Display Format	960×234	dot
Active Area	130.6 (H)×97.3 (V)	mm
Dot Pitch	0.136 (H)×0.416 (V)	mm
Pixel Configuration	Stripe	
Outline Dimension	156.3 (W)×119.8 (H)×14.3 (D)	mm
Weight	285±5	g

4.Mechanical Drawing of TFT-LCD Module

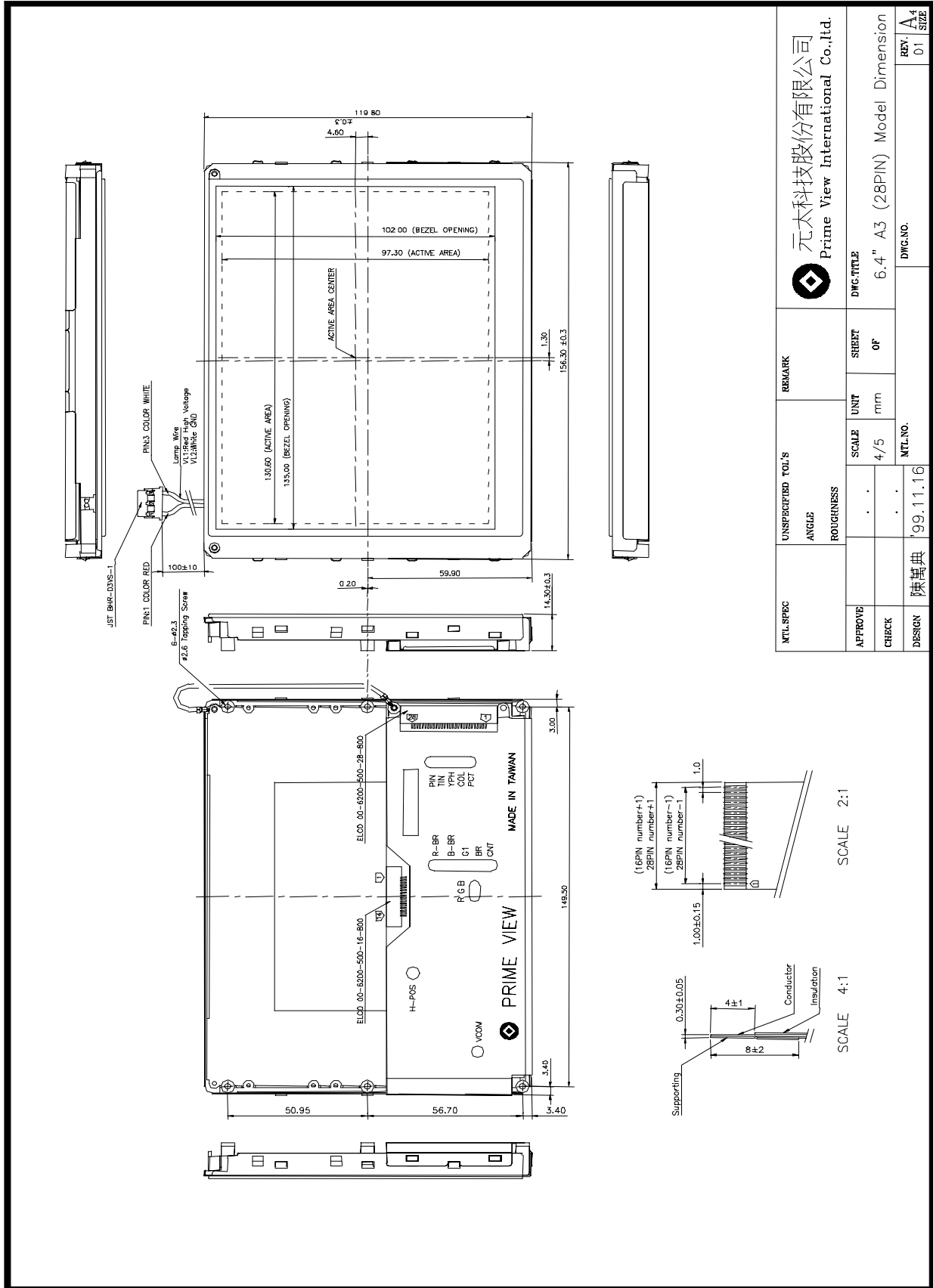

MTL SP/PC	UNSPECIFIED TOL'S	REMARK	元太科技股份有限公司 Prime View International Co.,Ltd.	
APPROVE	ANGLE	SHEET	DWG.TITLE	6.4" A3 (28PIN) Model Dimension
CHECK	ROUGHNESS	OF	DWG.NO.	
DESIGN	SCALE	UNIT	MTL.NO.	REV.
	4/5	mm	'99.11.16	01
				SIZE
				A4

5. Input / Output Terminals

5-1) TFT-LCD Panel Driving

A) Connector 1(28 Pins)

Pin No	Symbol	I/O	Description	Remark
1	BRI	I	Brightness adjustment	Note 5-1
2	CNT	I	Contrast adjustment	Note 5-1
3	NC		No connection	
4	COL	I	Color adjustment	Note 5-1
5	NC		No connection	
6	VIN	I	Composite video input	
7	GND	I	Video ground	
8	B	I	Video signal (Blue)	Note 5-2
9	G	I	Video signal (Green)	Note 5-2
10	R	I	Video signal (Red)	Note 5-2
11	SW	I	Composite or RGB input selection pin	Note 5-3
12	RL	I	Right or left direction selection pin	Note 5-4
13	VIY	I	Vertical sync. input	
14	CSY	I	Composite sync. or horizontal sync. input	Note 5-5
15	$\overline{\text{VSY}}$	I/O	Vertical sync. input/output	Note 5-5
16	$\overline{\text{HSY}}$	I/O	Horizontal sync. input/output	Note 5-5
17	CKC	I	Control pin for select signal	Note 5-5
18	VGA	I	QVGA function select pin	Note 5-6
19	HPS	I	H-position adjustment	Note 5-1
20	NPC	I/O	NTSC/PAL Input or Output	Note 5-10
21	VDD	O	+5V power output	
22	12G2	I	12V _{DC} power input ground	Note 5-9
23	12G1	I	12V _{DC} power input ground	Note 5-9
24	12V2	I	12V _{DC} power input	Note 5-9
25	12V1	I	12V _{DC} power input	Note 5-9
26	GND	I	Ground	
27	DIM	I	Dimmer adjustment for inverter	Note 5-7, 5-9
28	ENB	I	Enable signal for inverter	Note 5-8, 5-9

Note 5-1: It will be used the default value if the pin is opened.

Note 5-2: 0.7 V_{PP} standard RGB signal.

Note 5-3: Default (Hi, 5V) RGB input.

Note 5-4: Default (Hi, 5V) shift right.

Note 5-5: CKC pin can select the function of pin 16,15,14 as following:

CKC	Pin 16	Pin 15	Pin 14
Hi (+5V, default)	HSY output	VSY output	CSY Input
Low (0V)	HSY input	VSY input	clock input(18.9MHz)

Note 5-6: Hi(+5V) for VGA input, Low(0V, default) for NTSC or RGB input ◦

The relationship of SW pin & VGA pin is defined as following table:

SW	VGA	Selected input
0	0	TV mode - Composite input
0	1	NO USE
1	0	TV mode - R.G.B. input
1	1	VGA input

Note 5-7: Range: 0~2 ; open (default) : full light

Note 5-8: 0V to shunt down; 5V or open to enable

Note 5-9: These pins direct pass to the Switching Power Supply 16pin connector

Note 5-10: NTSC=Hi(+5V),PAL=LOW(0V). Generally, this pin will output the auto-detect signal (NTSC=1, PAL=0). However, if force the signal to high or low, the auto-detect function will be disabled.

B) Connector 2(16 Pins)

Pin No	Symbol	I/O	Description	Remark
1	12V1	O	12V output to power supply	Note 5-11
2	12V2	O	12V output to power supply	Note 5-11
3	12G1	O	Ground for 12V	Note 5-11
4	12G2	O	Ground for 12V	Note 5-11
5	DIM	I	Adjust backlight(0~2V analog input)	
6	ENB	I	Power down mode enable	
7	13V	I	13V input	
8	GND	I	Ground for 14V input	
9	V _{EE}	I	14V input	
10	GND	I	Ground for 5V input	
11	V _{DD}	I	5V input	
12	PSC	O	Synchronized signal for converter	
13	PSI	O	Synchronized signal for inverter	
14	-5V	I	-5V input	
15	GND	I	Ground for 20V	
16	20v	I	20v Input	

Note 5-11 : 12V_{DC} output from pin22~25 of 28-pin connector

5-2) Backlight driving

Pin No	Symbol	Description	Remark
1	VL1	Input terminal (Hi voltage side)	
2	VL2	Input terminal (Low voltage side)	Note 5-12

Note 5-12 : Low voltage side of backlight inverter connects with ground of inverter circuits.

5-3) Input / Output Connector

A) Video Input Connector

ELCO 00-6200-500-028-800

Down Connector

Pin No. : 28

Pitch : 1.0 mm

B) Power Input Connector

ELCO 00-6200-500-016-800

Pin No :16

Pitch :1.0 mm

C) Backlight Connector

JST BHR-03VS-1

Pin No. : 3

Pitch : 4 mm

6.Absolute Maximum Ratings:

Parameter	Symbol	MIN.	MAX.	Unit	Remark	
Supply Voltage for Source Driver	V _{SH}	-0.5	+16	V		
Supply Voltage for Gate Driver	L Level	V _{GL}	-7	20	V	
	L Level	V _{GL}	-7	+20	V	
Supply voltage for controller	V _{DD}	-0.3	+6.5	V		
DC bias voltage of common electrode	V _{com}	+2	+6	V		
Analog input signals	V _B , V _R , V _G		12	V		
Digital input signals		-0.5	5.5	V	Note 6-1	
Digital output signals		-0.5	5.5	V	Note 6-2	
Storage Temperature		-30	+80	°C		
Operation Temperature		-10	+60	°C		

Note 6-1: $\overline{\text{HSY}}$, $\overline{\text{CSY}}$, $\overline{\text{VSY}}$, $\overline{\text{CKC}}$

Note 6-2: $\overline{\text{HSY}}$, $\overline{\text{VSY}}$, $\overline{\text{PSI}}$, $\overline{\text{PSC}}$

7. Electrical Characteristics

7-1) Recommended Operating Conditions:

A) Driving for TFT-LCD panel

GND = 0V , Ta = 25 °C

Parameter	Symbol	MIN.	TYP	MAX.	Unit	Remark	
Supply voltage for source driver	V _{SH}	+13.5	+14	+14.5	V		
Supply voltage for gate driver	H Level	V _{GH}	+19	+20	+24	V	
	L level	V _{GL}	-5.5	-5	-4	V	
Supply voltage for controller	V _{DD}	+4.7	+5	+5.3	V		
Analog input signal	V _R ,V _G ,V _B						
Digital input voltage	H level		+2.4	-	+5	V	Note 7-1
	L level		-0.3	-	+0.8	V	
Digital output voltage	H level		+2.4	+4	+5	V	Note 7-2
	L level		0	-	+0.45	V	

Note 7-1 : $\overline{\text{HSY}}$, $\overline{\text{CSY}}$, $\overline{\text{VSY}}$, $\overline{\text{CKC}}$

Note 7-2 : $\overline{\text{HSY}}$, $\overline{\text{VSY}}$, $\overline{\text{PSI}}$, $\overline{\text{PSC}}$

B) Power on sequence(Voltage source)

The Power on sequence only effect by V_{DD},V_{GL} and V_{GH}, the others do not care.

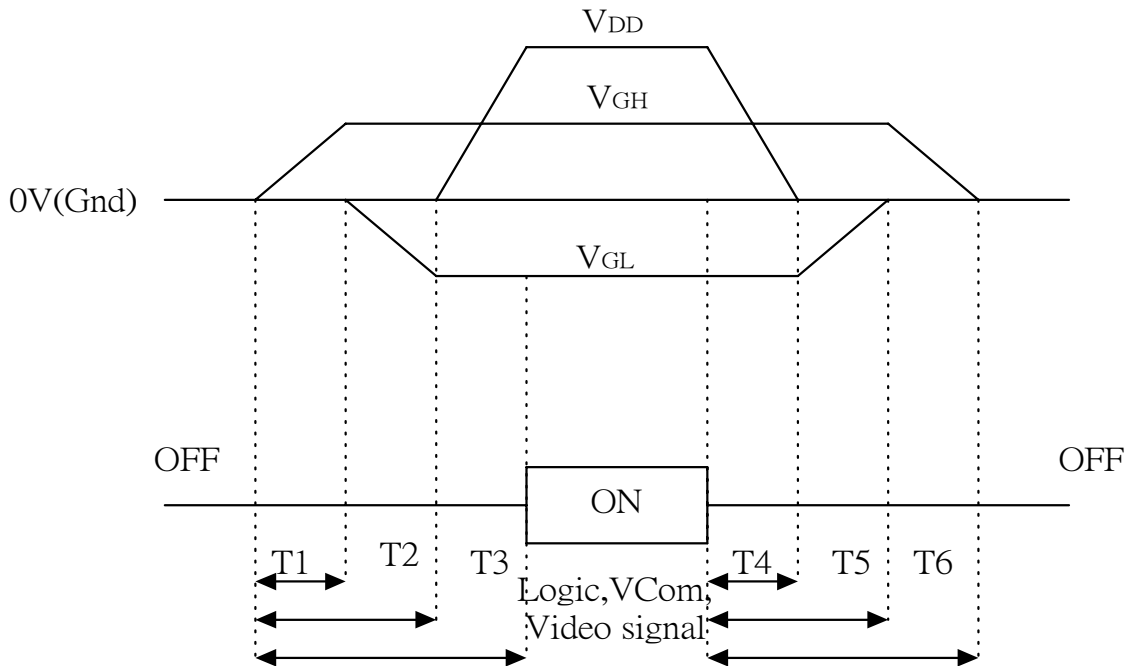

1) $10\text{ms} \leq T1 \leq T2 \leq T3$

2) $10\text{ms} \leq T4 \leq T5 \leq T6$

C) Driving for backlight

Ta= 25 °C

Parameter	Symbol	Min.	Typ.	Max.	Unit	Remark
Lamp voltage	V _L	480	520	560	Vrms	I _L =6mA
Lamp current	I _L	4	6	8	mA	
Lamp frequency	P _L	20		60	KHz	Note 7-3
Kick-off voltage	V _s			1500	Vrms	

Note 7-3 : The wave form of lamp driving voltage should be as closed to a perfect sine wave as possible.

7-2) Power Consumption

Ta= 25 °C

Parameter	Symbol	Conditions	TYP.	Unit	Remark
Supply current for Gate Driver (Hi level)	I _{GH}	V _{GH} = +20V	6.0	mA	
Supply current for Gate Driver (Low level)	I _{GL}	V _{GL} = -5V	5.0	mA	
Supply current for Source Driver	I _{SH}	V _{EE} = +14V	9.0	mA	
Supply current for controller	I _{DD}	V _{DD} = +5V	50.0	mA	
Supply current	I _{CC}	V _{CC} = +13V	3.0	mA	
TFT-LCD Panel Power Consumption			0.56	W	Note 7-4
Backlight Lamp Power Consumption			3.12	W	Note 7-5

Note 7-4 : The power consumption for backlight is not included.

Note 7-5 : Backlight lamp power consumption is calculated by I_L × V_L.

7-3) Input / Output signal timing chart

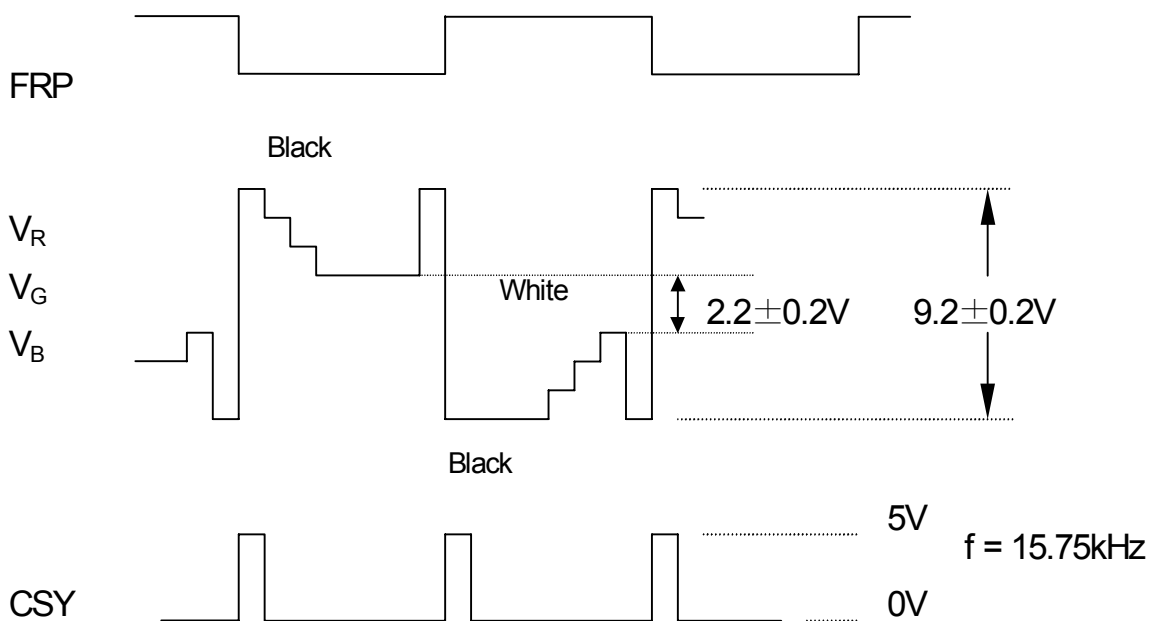

Parameter	Symbol	MIN.	TYP.	MAX.	Unit	Remarks
Horizontal Sync. Output Pulse	Width	T_{HO}	4.2	4.7	5.2	μs
	Phase Difference	T_{HP}	0	2		μs
	Rising Time	T_{HR}	-	-	0.5	μs
	Falling Time	T_{HF}	-	-	0.5	μs
Vertical Sync. Output Pulse	Width	T_{VO}	-	4H	-	μs H=1/15.75KHz
	Phase Difference	T_{VPO}	-	1H	-	μs odd field
	Phase Difference	T_{VPE}	-	1.5H	-	μs even field
	Rising Time	T_{VR}	-	-	2	μs
Polarity Alternating Signal	Delay time	T_{FD}	-	-	4	μs
	Falling Time	T_{VF}	-	-	2	μs

7-4) Display Time Range

A) When sync. signal of NTSC system is applied.

- a) Horizontally
12.6 ~ 63.39 μs .
- b) Vertical
19 ~ 253 H

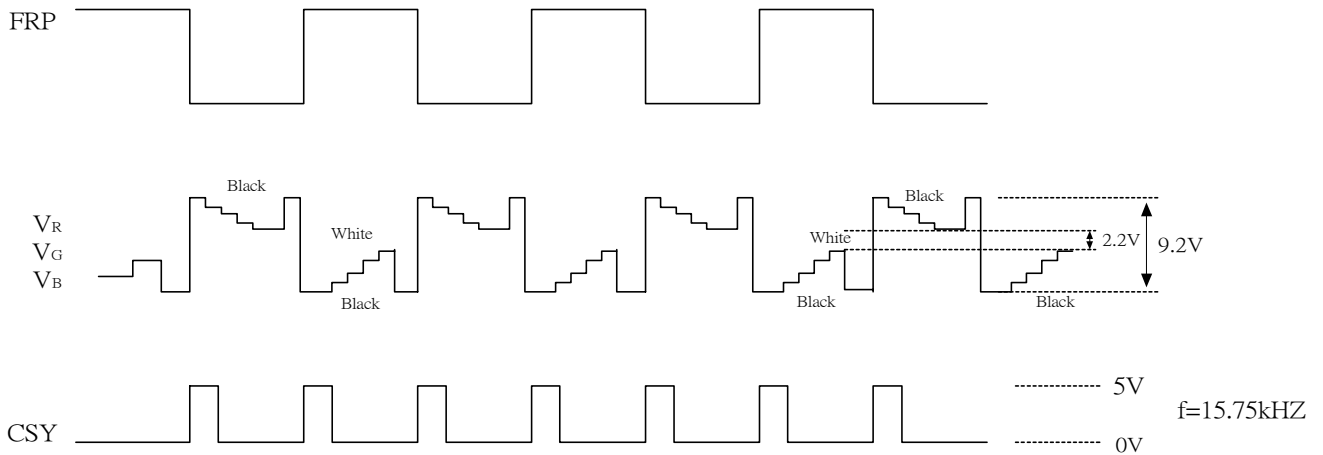

B) When sync. signal of PAL system is applied.

- a) Horizontally
13.0 ~ 63.8 μs
- b) Vertical
26 ~ 298 H
- c) odd field : Scan lines $14n+17$ $14n+23$ ($n = 1, 2, 3..$) are not displayed.
even field : Scan lines $14n+12$ $14n+20$ ($n = 1, 2, 3..$) are not displayed.

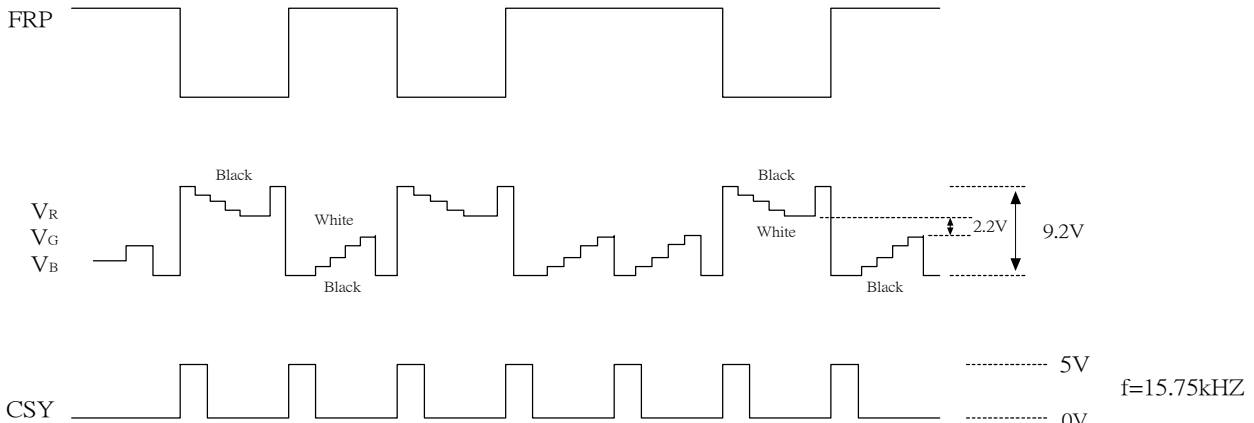

C) NTSC Timing Diagram

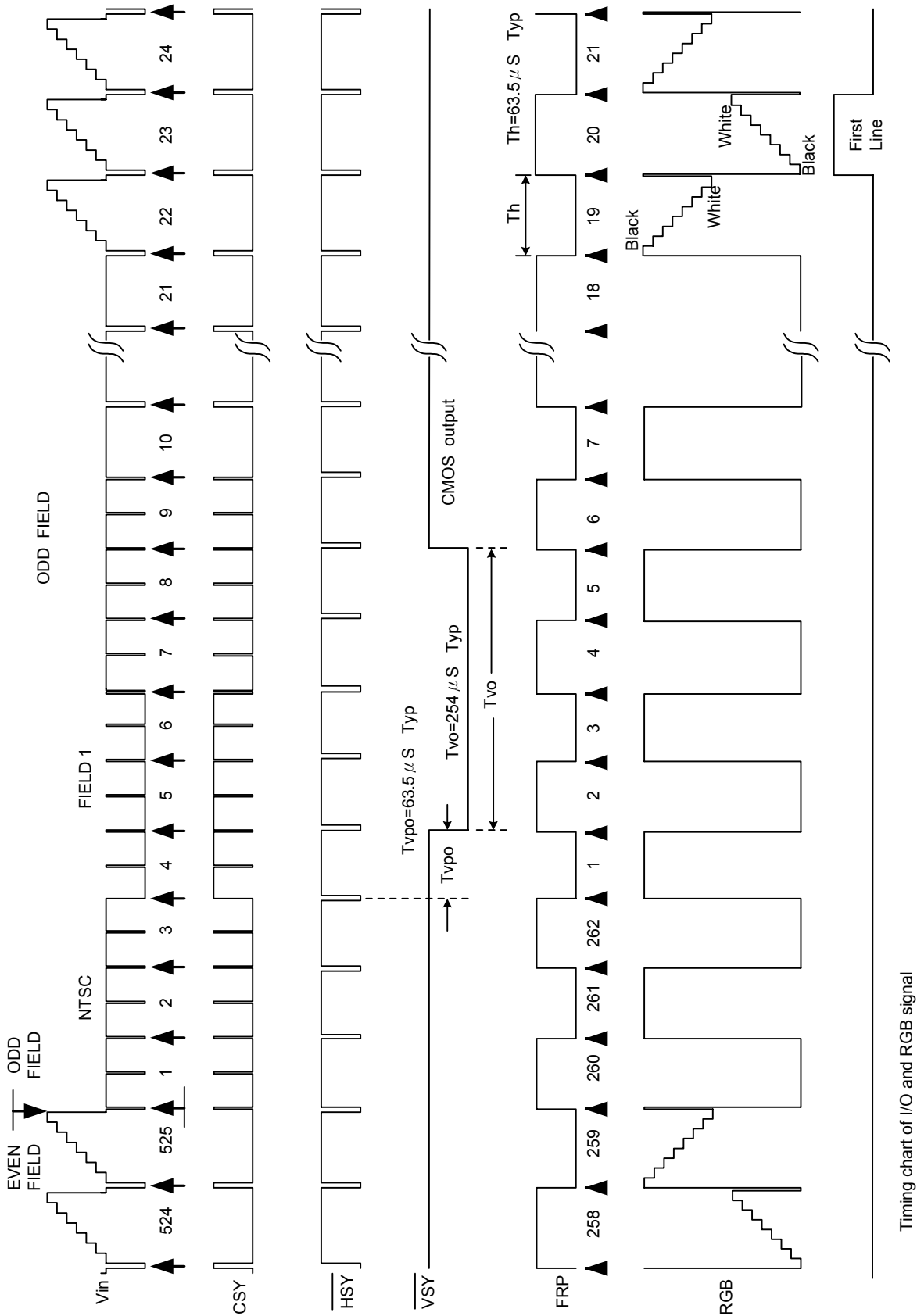

Timing chart of I/O and RGB signal

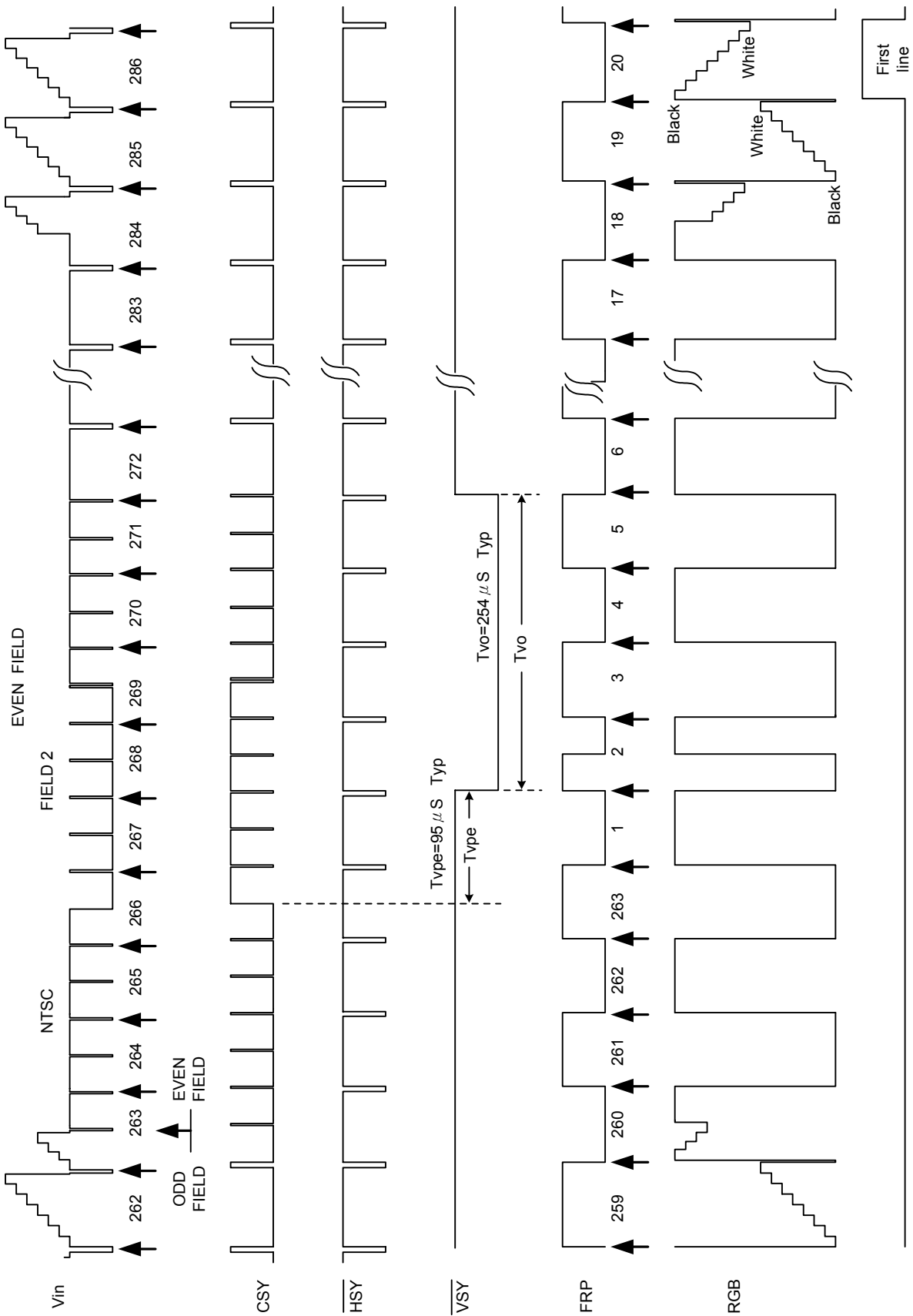

Timing chart of I/O and RGB signal

NTSC Display Timing

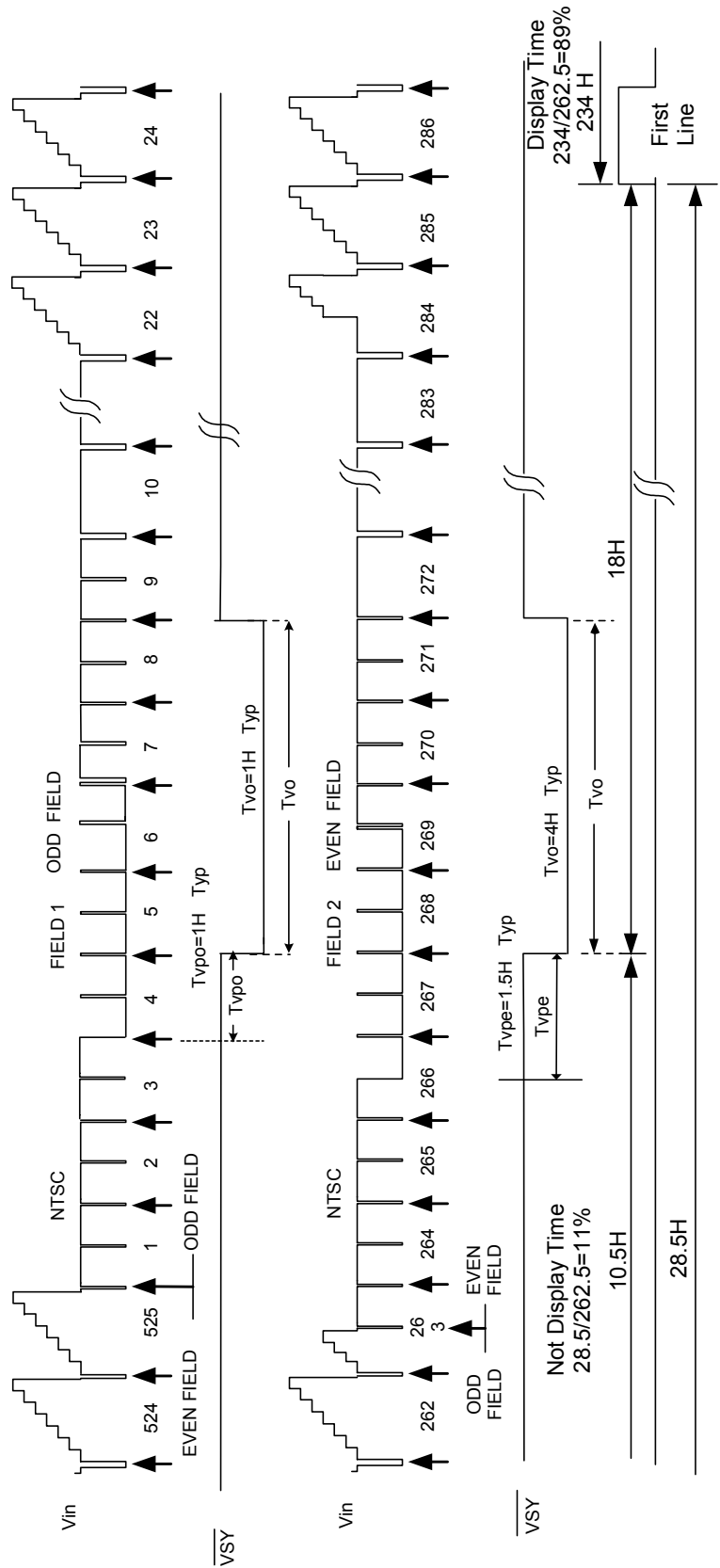
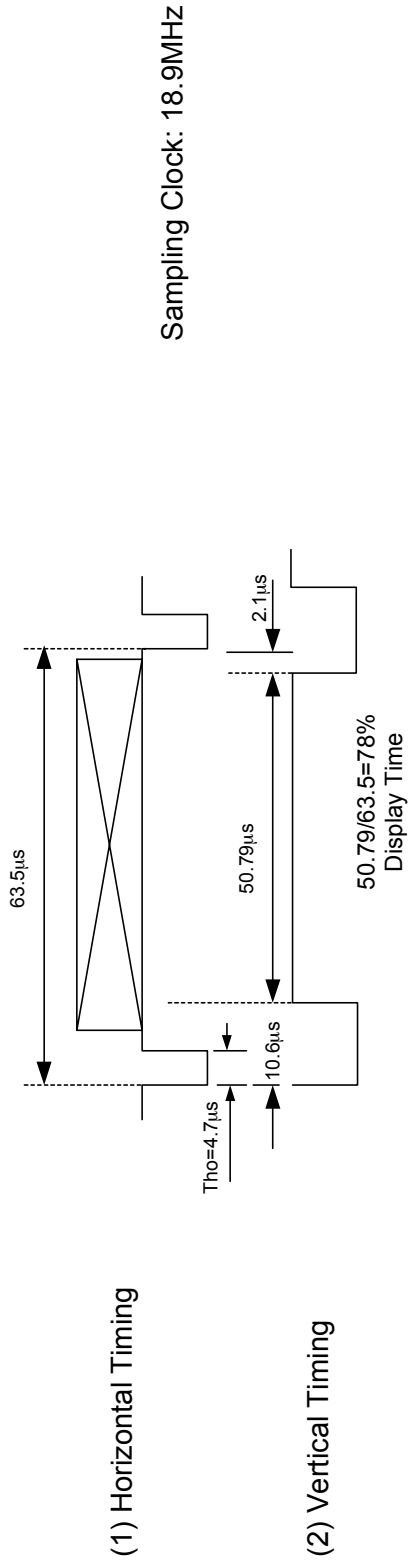

D) PAL System

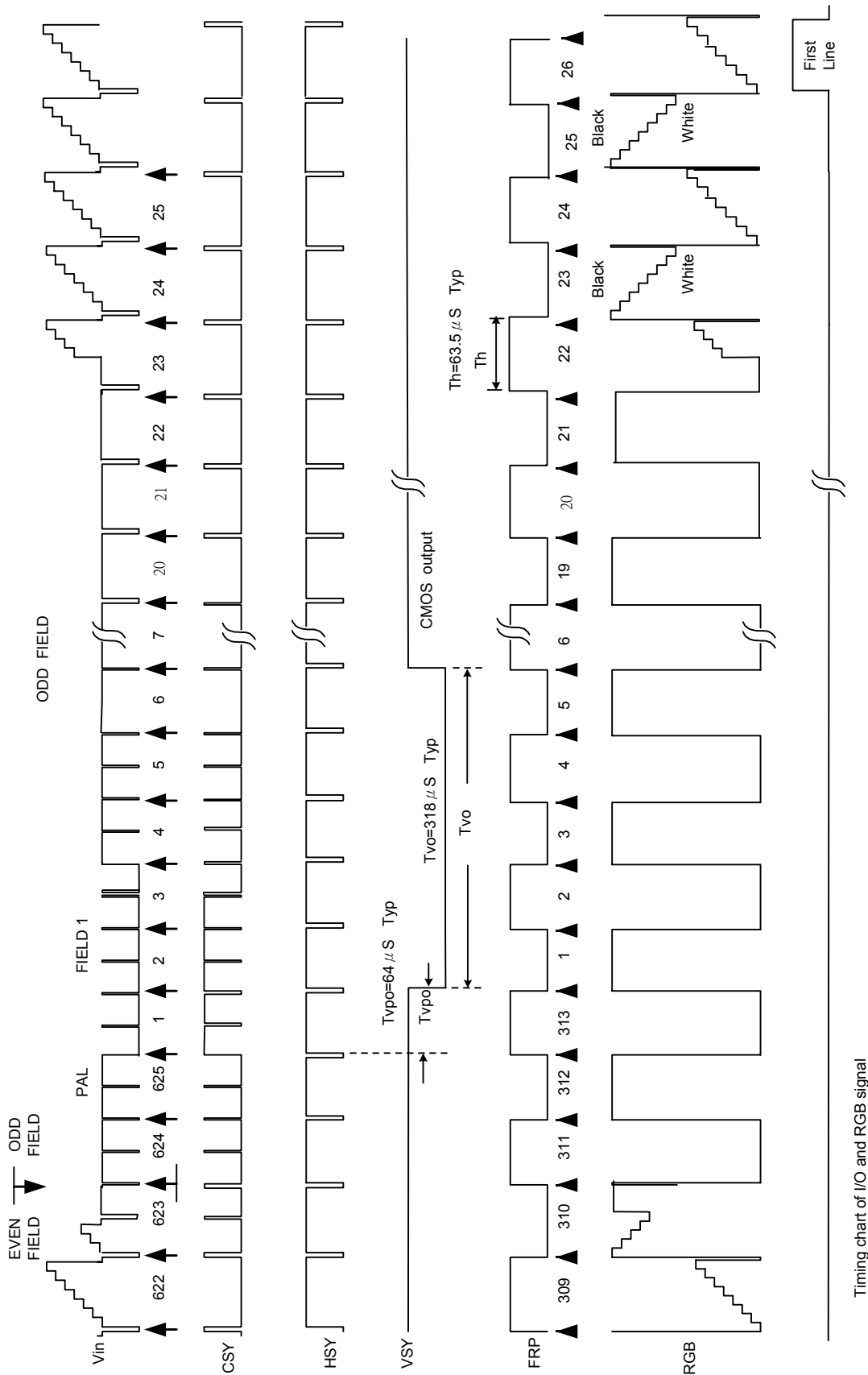

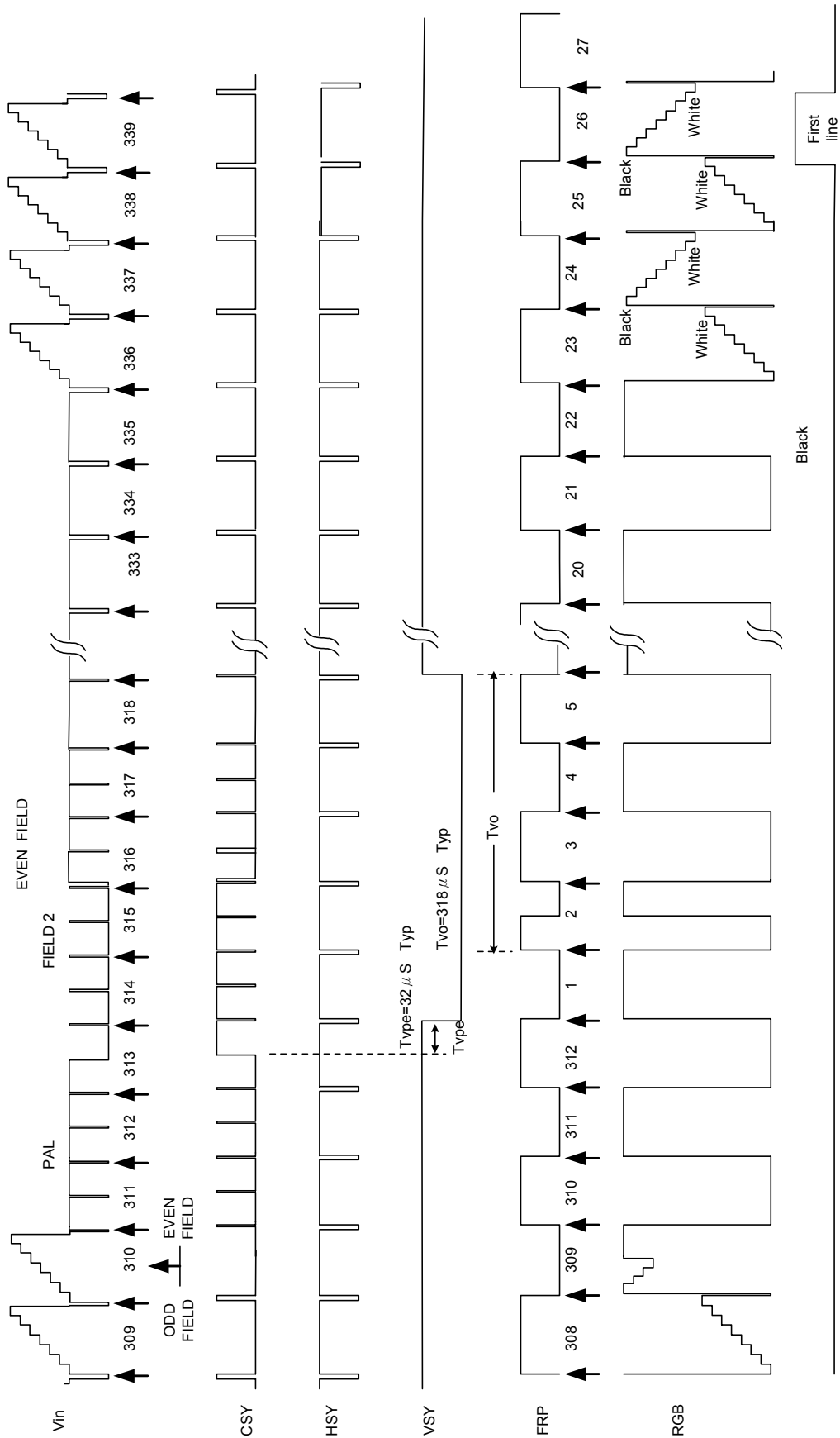

Timing chart of I/O and RGB signal

PAL Display Timing

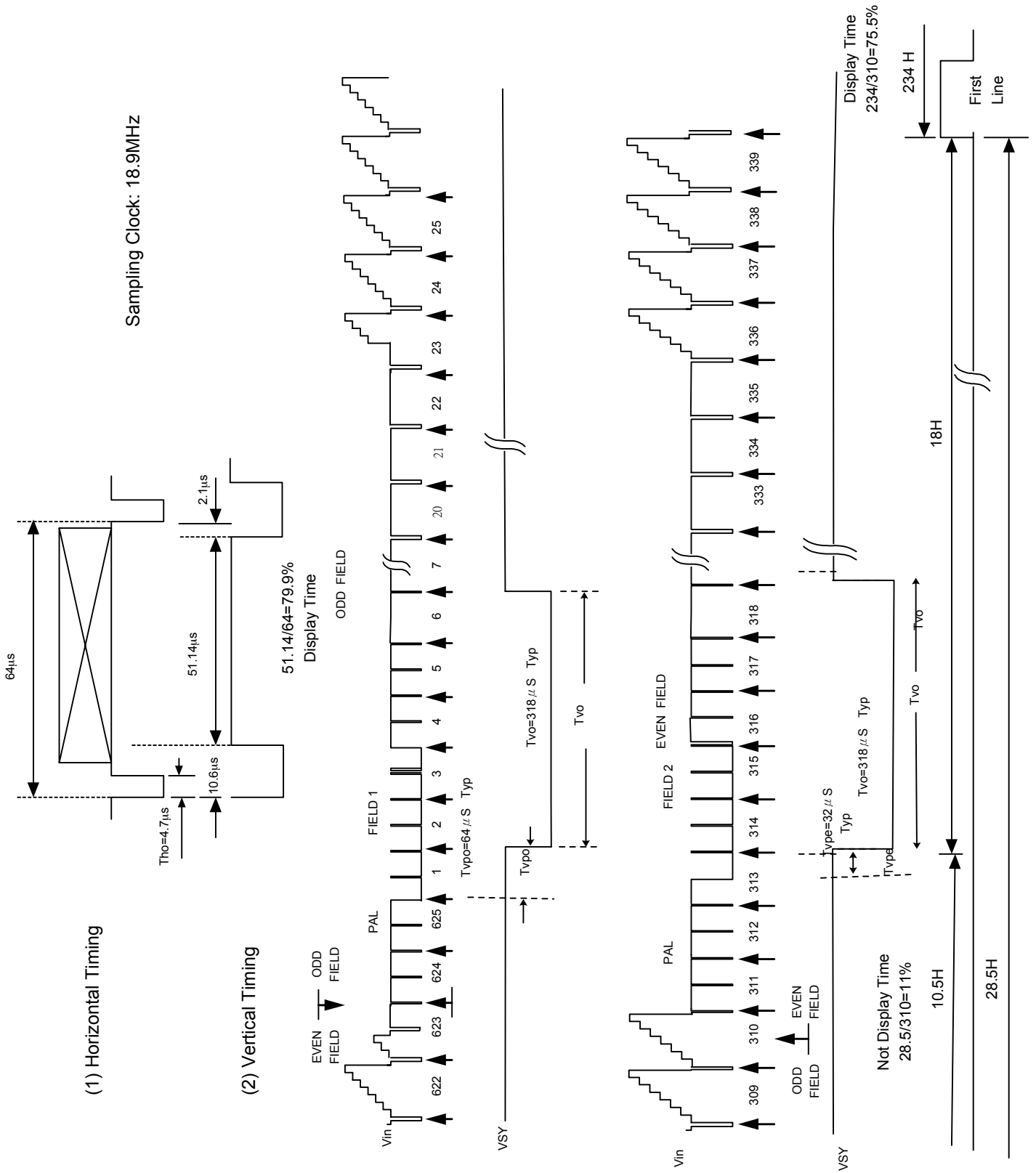

8. Optical Characteristics

8-1) Specification:

Ta = 25°C

Parameter	Symbol	Condition	MIN.	TYP.	MAX.	Unit	Remarks	
Viewing Angle	Horizontal	CR > 10	± 50	± 60		deg	Note 8-1	
	Vertical		θ (to 12 o'clock)	10	15		deg	
			θ (to 6 o'clock)	30	35		deg	
Contrast Ratio	CR		80	120			Note 8-2	
Response time	Rise	θ = 0°			30	ms	Note 8-4	
	Fall				50	ms		
Reflectance Ratio	R			6.0		%		
Brightness			250	300		cd/m ²	Note 8-3	
White Chromaticity	x		0.255	0.305	0.355		Note 8-3	
	y		0.300	0.350	0.400		Note 8-3	
Lamp Life Time		+25°C	10,000			hr		

Note 8-1 : The definition of viewing angle diagrams:.

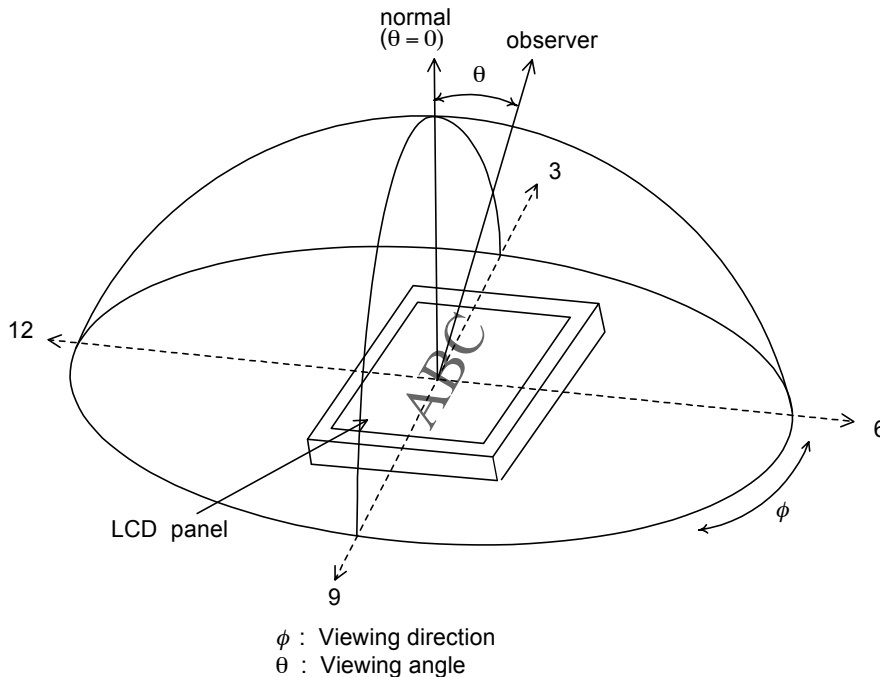

Note 8-2 : $CR = \frac{\text{Luminance when Testing point is White}}{\text{Luminance when Testing point is Black}}$
 (Testing configuration see section 8-2)
 Contrast Ratio is measured in optimum common electrode voltage.

Note 8-3 : Topcon BM-7(fast) luminance meter 2° field of view is used in the testing (after 20~30 minutes operation).
 Lamp Current 6mA

Note 8-4: The definition of response time:

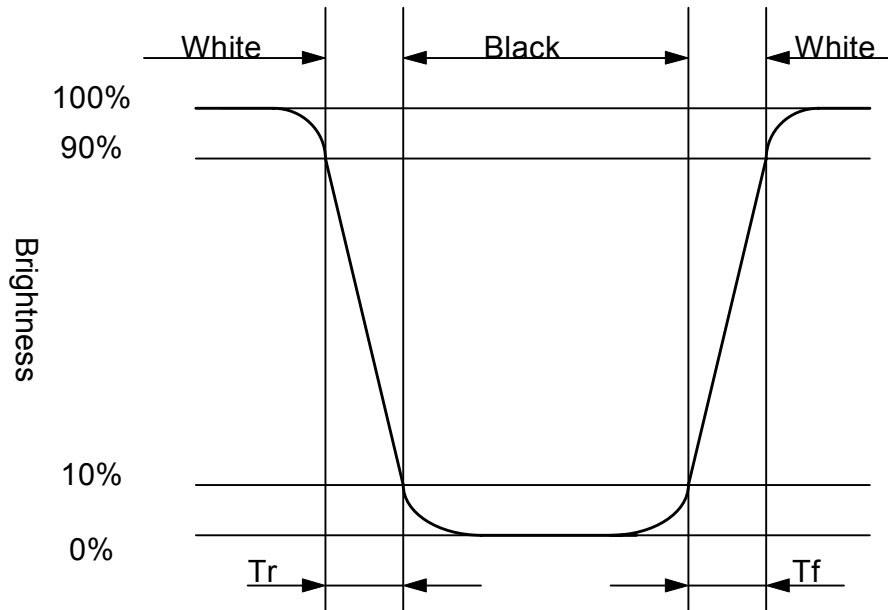

8-2) Testing configuration

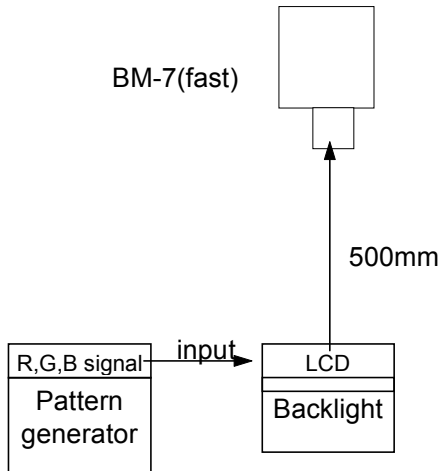

Caution: 1. Environmental illumination ≤ 1 lux
 2. Before test CR, Vcom voltage must be adjusted carefully to get the best CR.

- LCD Display Testing Point Testing Point

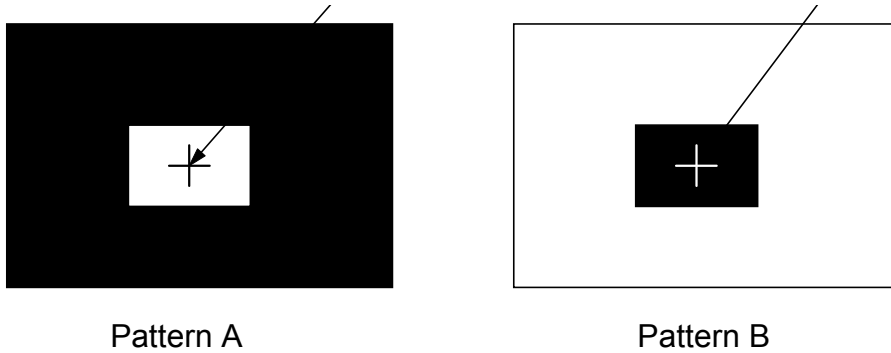

- R, G, B Waveform of Pattern A at Testing Point

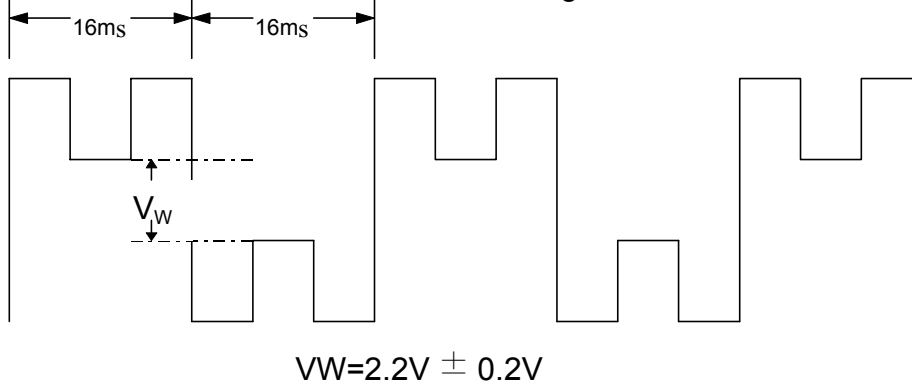

- G, B Waveform of Pattern B at Testing Point

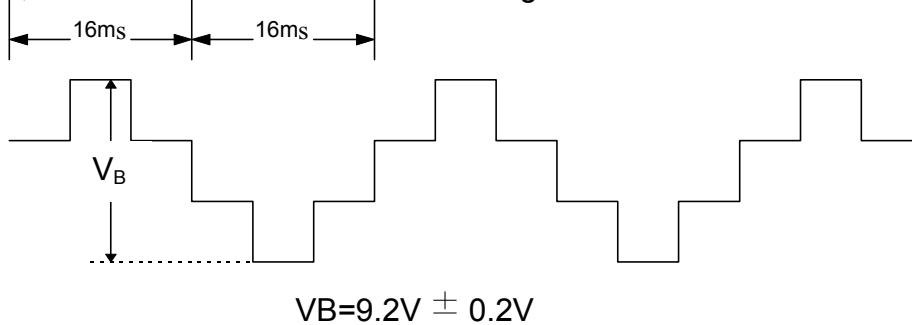

9. Handling Cautions**9-1) Mounting of module**

- a) Please power off the module when you connect the input/output connector.
- b) Please connect the ground pattern of the inverter circute surely. If the connection is not perfect, some following problems may happen possibly.
 - 1.The noise from the backlight unit will increase.
 - 2.The output from inverter circuit will be unstable.
 - 3.In some cases a part of module will heat.
- c) Polarizer which is made of soft material and susceptible to flaw must be handled carefully.
- d) Protective film (Laminator) is applied on surface to protect it against scratches and dirt. It is recommended to peel off the laminator before use and taking care of static electricity.

9-2) Precautions in mounting

- a) When metal part of the TFT-LCD module (shielding lid and rear case) is soiled, wipe it with soft dry cloth.
- b) Wipe off water drops or finger grease immediately. Long contact with water may cause discoloration or spots.
- c) TFT-LCD module uses glass which breaks or cracks easily if dropped or bumped on hard surface. Please handle with care.
- d) Since CMOS LSI is used in the module. So take care of static electricity and earth yourself when handling.

9-3) Adjusting module

- a) Adjusting volumes on the rear face of the module have been set optimally before shipment.
- b) Therefore, do not change any adjusted values. If adjusted values are changed, the specifications described may not be satisfied.

9-4) Others

- a) Do not expose the module to direct sunlight or intensive ultraviolet rays for many Hours.
- b) Store the module at a room temperature place.
- c) The voltage of beginning electric discharge may over the normal voltage because of leakage current from approach conductor by to draw lump read lead line around.
- d) If LCD panel breaks, it is possibly that the liquid crystal escapes from the panel. Avoid putting it into eyes or mouth. When liquid crystal sticks on hands, clothes or feet. Wash it out immediately with soap.
- e) Observe all other precautionary requirements in handling general electronic components.
- f) Please adjust the voltage of common electrode as material of attachment by 1 module.

10. Reliability Test

No	Test Item	Test Condition
1	High Temperature Storage Test	Ta = +80 °C, 240 hrs
2	Low Temperature Storage Test	Ta = -30°C, 240 hrs
3	High Temperature Operation Test	Ta = +60 °C, 240 hrs
4	Low Temperature Operation Test	Ta = -10 °C, 240 hrs
5	High Temperature & High Humidity Operation Test	Ta = +60°C, 95%RH, 240 hrs
6	Thermal Cycling Test (non-operating)	-25°C → +25°C → +70°C, 200 Cycles 30 min 5min 30 min
7	Vibration Test (non-operating)	Frequency : 10 ~ 55 Hz Amplitude : 1.5 mm Sweep time: 11 mins Test period: 6 Cycles for each direction of X, Y, Z
8	Shock Test (non-operating)	100G, 6ms Direction: ±X, ±Y, ±Z Cycle: 3 times
9	Electrostatic Discharge Test (non-operating)	150pF, 330Ω Air: ±15KV; Contact: ±8KV 10 times/point, 9 points/panel face

Ta: ambient temperature

[Judgement Criteria]

Under the display quality test conditions with normal operation state, there should be no change which may affect practical display function.

11. Indication of Lot Number Label

a) Indicated contents of the label

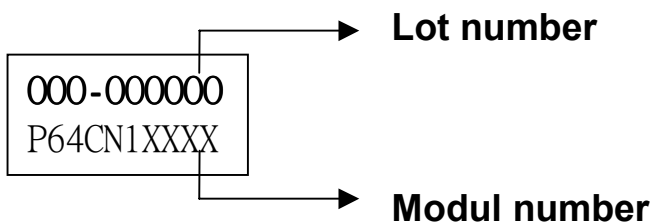

Contents of lot number : 1st—Process area : class 1000 ⇒ H
class 100K ⇒ M

2nd~3rd—Module screen size(in inch) : 1.8"⇒18, 2.5"⇒25.....

5th—Production year : 1999⇒9, 2000⇒A, 2001⇒1.....

6th—Production month : 1, 2, 3,.....9, A, B, C

7th~10th—Serial numbers : 0001~9999

12. Block Diagram

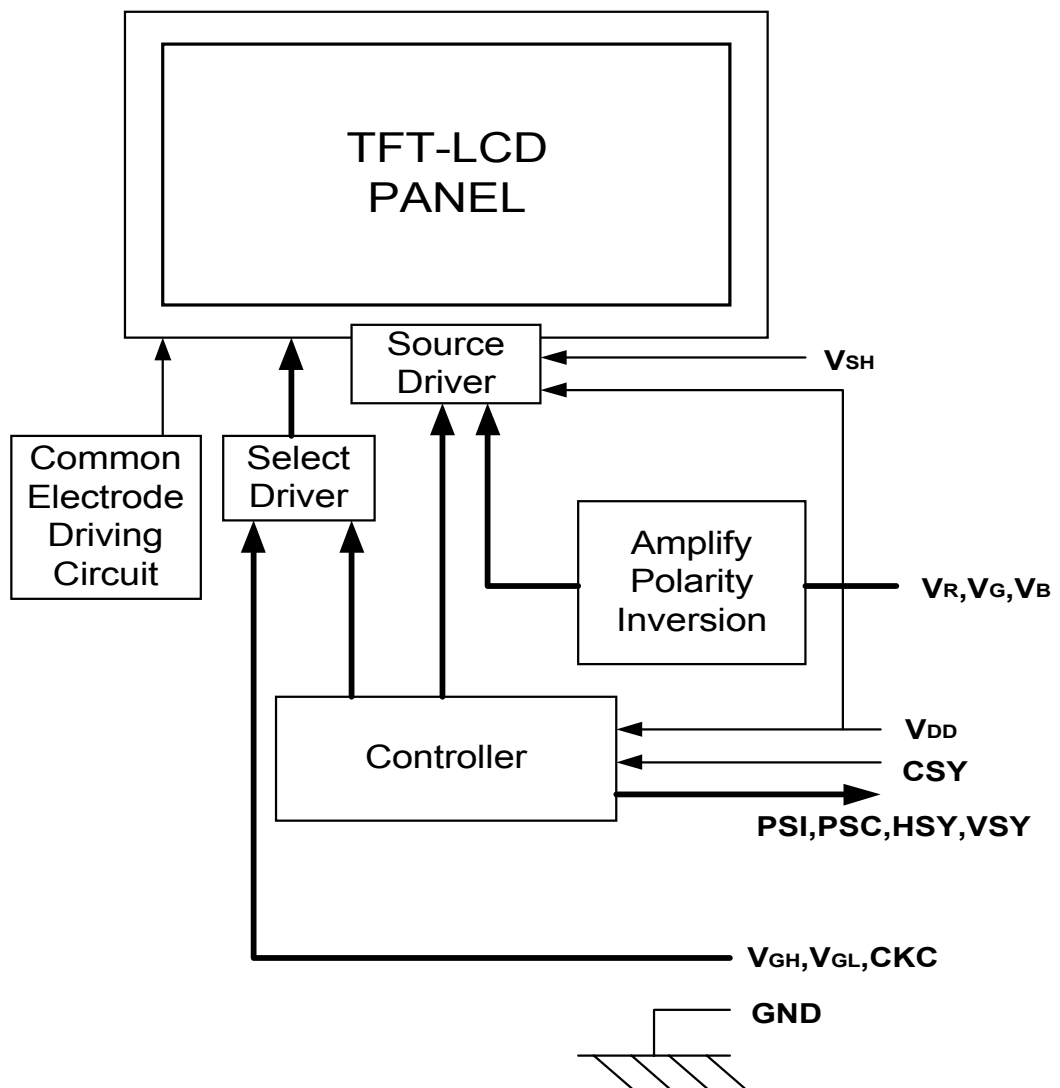

13. Packing

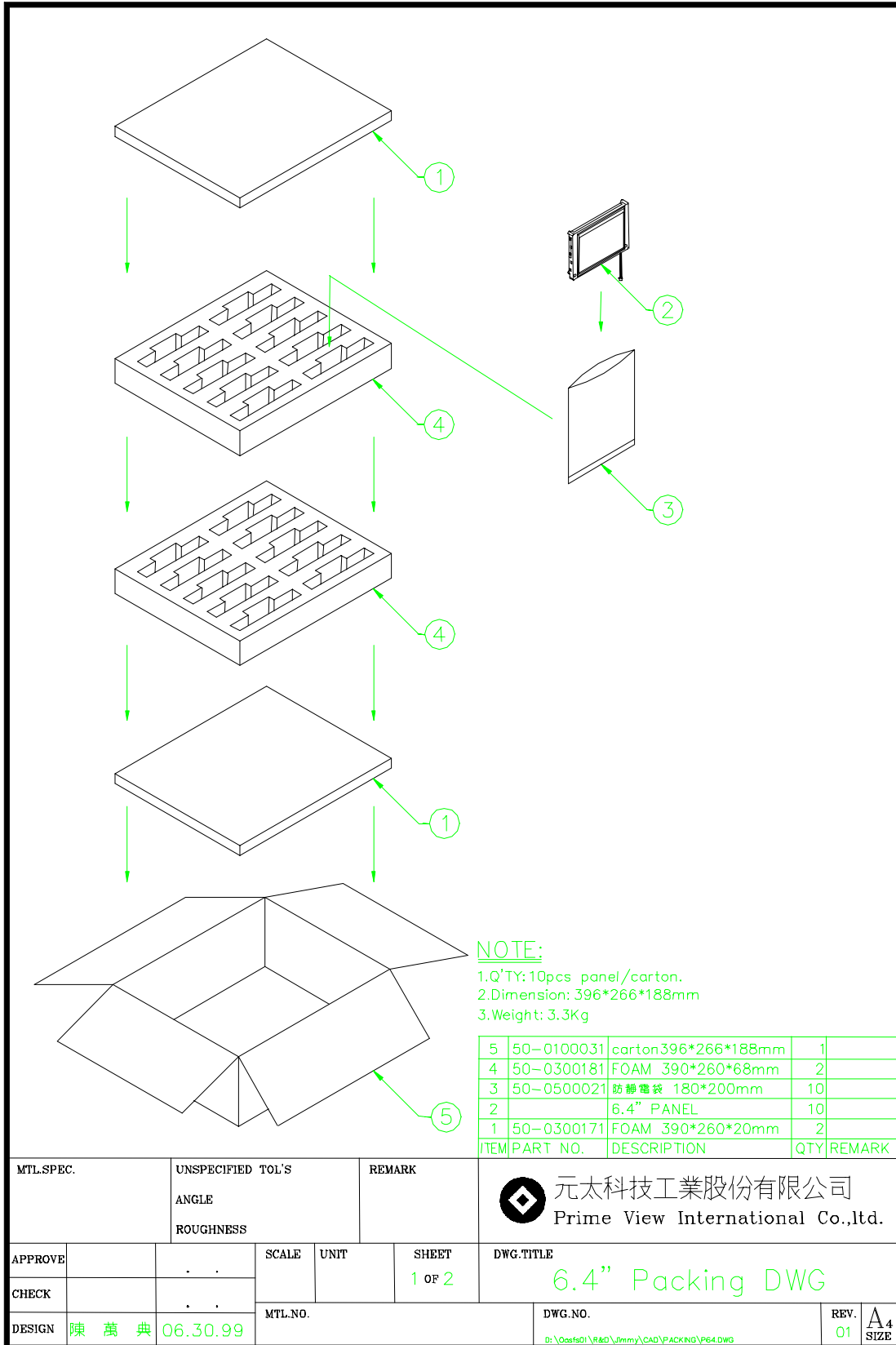

Revision History

Rev.	Issued Date	Revised Contents
1	Nov. 10, 1999	NEW
1.1	Mar. 05, 2001	Page 3: Mechanical Specifications(Weight range) Page 8: Add power on sequence Page 9: Driving for TFT-LCD panel(Add panel driving chart.) Page 10: Display Time Range(Add NTSC & PAL chart.) Page 20: Add Handling Cautions Page 21 Add Indication of Lot Number Label