

P6803HVG

Dual N-Channel Enhancement Mode MOSFET

PRODUCT SUMMARY

$V_{(BR)DSS}$	$R_{DS(ON)}$	I_D
30V	58mΩ @ $V_{GS} = 10V$	4.5A

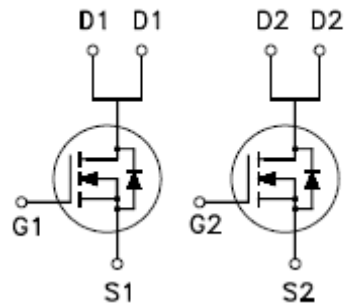
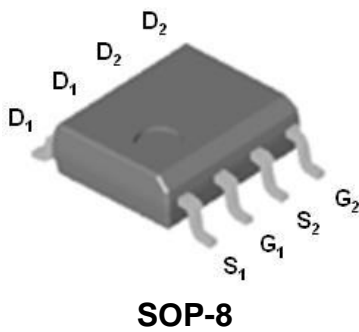

ABSOLUTE MAXIMUM RATINGS ($T_A = 25\text{ }^\circ\text{C}$ Unless Otherwise Noted)

PARAMETERS/TEST CONDITIONS		SYMBOL	LIMITS	UNITS
Drain-Source Voltage		V_{DS}	30	V
Gate-Source Voltage		V_{GS}	± 20	
Continuous Drain Current	$T_A = 25\text{ }^\circ\text{C}$	I_D	4.5	A
	$T_A = 70\text{ }^\circ\text{C}$		3.6	
Pulsed Drain Current ¹		I_{DM}	20	
Power Dissipation	$T_A = 25\text{ }^\circ\text{C}$	P_D	2	W
	$T_A = 70\text{ }^\circ\text{C}$		1.3	
Junction & Storage Temperature Range		T_j, T_{stg}	-55 to 150	$^\circ\text{C}$

THERMAL RESISTANCE RATINGS

THERMAL RESISTANCE	SYMBOL	TYPICAL	MAXIMUM	UNITS
Junction-to-Ambient	$R_{\theta JA}$		62.5	$^\circ\text{C} / \text{W}$

P6803HVG

Dual N-Channel Enhancement Mode MOSFET

ELECTRICAL CHARACTERISTICS (T_A = 25 °C, Unless Otherwise Noted)

PARAMETER	SYMBOL	TEST CONDITIONS	LIMITS			UNITS
			MIN	TYP	MAX	
STATIC						
Drain-Source Breakdown Voltage	V _{(BR)DSS}	V _{GS} = 0V, I _D = 250μA	30			V
Gate Threshold Voltage	V _{GS(th)}	V _{DS} = V _{GS} , I _D = 250μA	1	1.5	3	V
Gate-Body Leakage	I _{GSS}	V _{DS} = 0V, V _{GS} = ±20V			±100	nA
Zero Gate Voltage Drain Current	I _{DSS}	V _{DS} = 24V, V _{GS} = 0V			1	μA
		V _{DS} = 20V, V _{GS} = 0V, T _J = 55 °C			10	
On-State Drain Current ¹	I _{D(ON)}	V _{DS} = 5V, V _{GS} = 10V	20			A
Drain-Source On-State Resistance ¹	R _{DS(ON)}	V _{GS} = 10V, I _D = 3.5A		44	58	mΩ
		V _{GS} = 5V, I _D = 2.5A		60	77	
Forward Transconductance ¹	g _{fs}	V _{DS} = 5V, I _D = 3.5A		4.5		S
DYNAMIC						
Input Capacitance	C _{iss}	V _{GS} = 0V, V _{DS} = 15V, f = 1MHz		200		pF
Output Capacitance	C _{oss}			40		
Reverse Transfer Capacitance	C _{rss}			20		
Total Gate Charge ²	Q _g	V _{DS} = 0.5V _{(BR)DSS} , V _{GS} = 10V, I _D = 3.5A		6.5		nC
Gate-Source Charge ²	Q _{gs}			1.2		
Gate-Drain Charge ²	Q _{gd}			1.6		
Turn-On Delay Time ²	t _{d(on)}	V _{DS} = 15V, R _L = 15Ω I _D ≅ 1A, V _{GS} = 10V, R _{GEN} = 6Ω		7		nS
Rise Time ²	t _r			12		
Turn-Off Delay Time ²	t _{d(off)}			12		
Fall Time ²	t _f			7		
SOURCE-DRAIN DIODE RATINGS AND CHARACTERISTICS(T_A = 25 °C)						
Continuous Current	I _S				1.6	A
Forward Voltage ¹	V _{SD}	I _F = 1A, V _{GS} = 0V			1.2	V
Reverse Recovery Time	t _{rr}	I _F = 1A, di _F /dt = 100A / μS		40		nS
Reverse Recovery Charge	Q _{rr}				80	

¹Pulse test : Pulse Width ≤ 300 μsec, Duty Cycle ≤ 2%.

²Independent of operating temperature.

P6803HVG

Dual N-Channel Enhancement Mode MOSFET

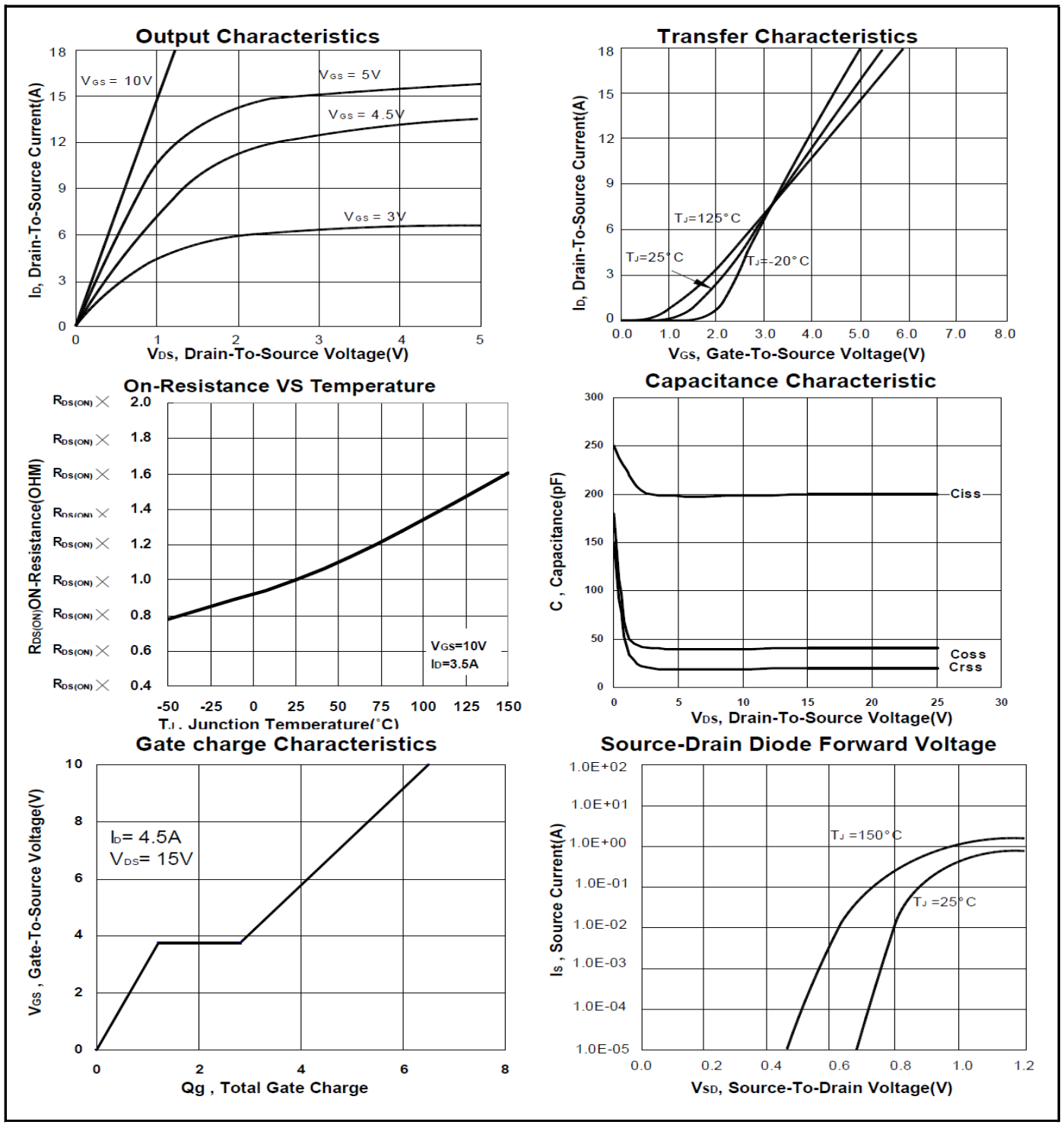

P6803HVG

Dual N-Channel Enhancement Mode MOSFET

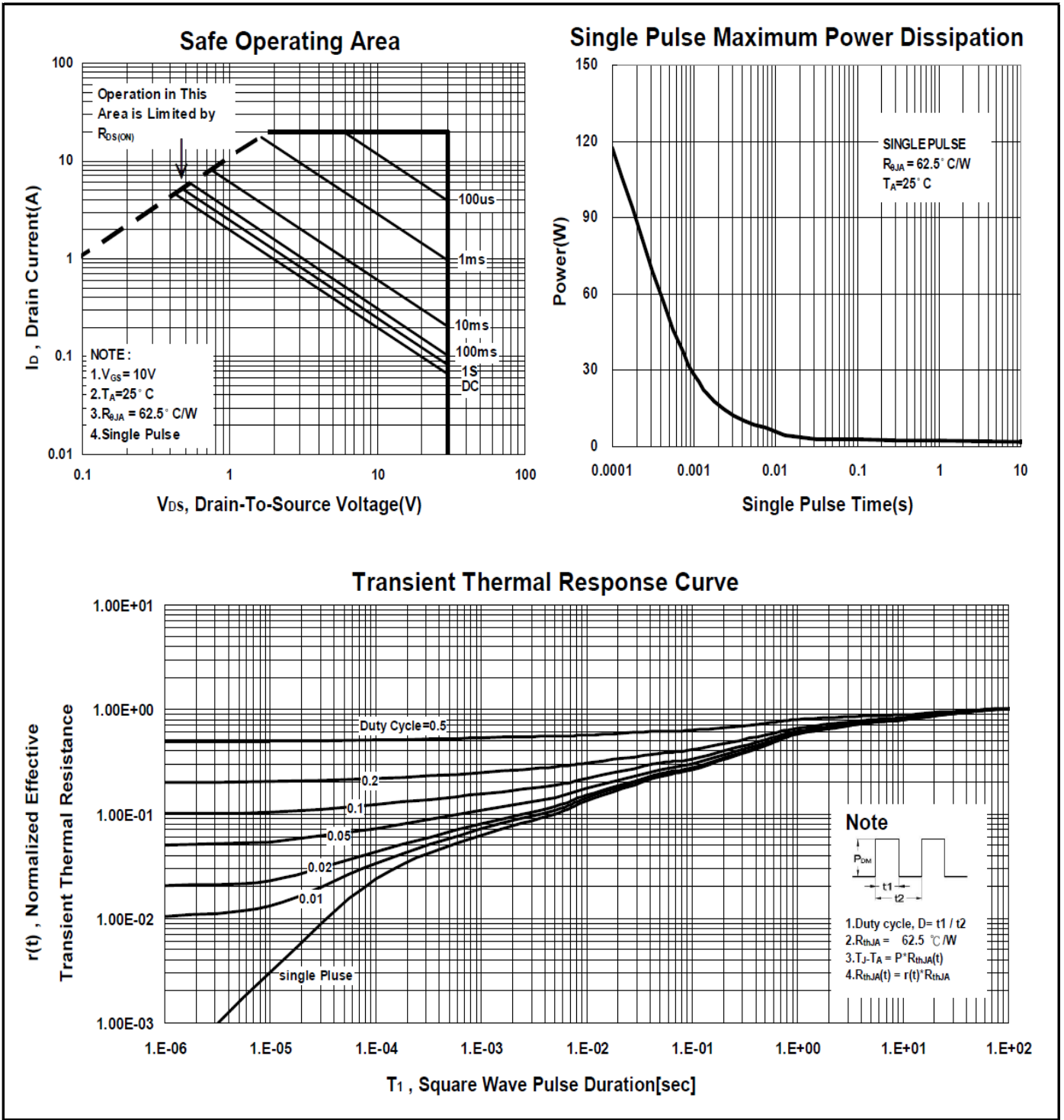

P6803HVG

Dual N-Channel Enhancement Mode MOSFET

Package Dimension

SOP-8 MECHANICAL DATA

Dimension	mm			Dimension	mm		
	Min.	Typ.	Max.		Min.	Typ.	Max.
A	4.8	4.9	5.0	H	0.4	0.6	0.93
B	3.8	3.9	4.0	I	0.19	0.21	0.25
C	5.79	6.0	6.2	J	0.25	0.375	0.5
D	0.33	0.4	0.51	K	0°	3°	18°
E	1.25	1.27	1.29				
F	1.1	1.3	1.65				
G	0.05	0.15	0.25				

